

MONACO MOTORHOME LIMITED WARRANTY

WHAT THE PERIOD OF COVERAGE IS:

This Limited Warranty provided by Monaco® (“Warrantor”) covers those components, assemblies and systems of your new motorhome not excluded under the section “What is Not Covered” and when sold by an authorized dealer, for twelve (12) months from the original retail purchase date or the first 24,000 miles of use, whichever occurs first. However, this Limited Warranty provided by Warrantor covers the steel or aluminum frame structure, only, of the sidewalls (excluding slide outs), roof, and rear and front walls for sixty (60) months from the original retail purchase date or the first 50,000 miles of use, whichever occurs first.

If you use your motorhome for any rental, commercial or business purposes whatsoever, the Limited Warranty provided by Warrantor covers your new motorhome when sold by an authorized dealer for ninety (90) days from the original retail purchase date or the first 24,000 miles of use, whichever occurs first. In addition, the Limited Warranty provided by Warrantor covers the steel or aluminum frame structure, only, of the sidewalls (excluding slide outs), roof, and rear and front walls for twelve (12) months from the original retail purchase date or the first 24,000 miles of use, whichever occurs first. A conclusive presumption that your motorhome has been used for commercial and/or business purposes arises if you have filed a federal or state tax form claiming any business tax benefit related to your ownership of the motorhome.

The above Limited Warranty coverage applies to all owners, including subsequent owners, of the motorhome. However, a subsequent owner must submit a warranty transfer form by filing the form through an authorized Monaco dealer. A subsequent owner’s warranty coverage period is the remaining balance of the warranty coverage period the prior owner was entitled to under this Limited Warranty. Warranty transfer forms can be obtained by contacting the Customer Relations Department. There is no charge for the transfer.

LIMITATION AND DISCLAIMER OF IMPLIED WARRANTIES:

IMPLIED WARRANTIES, IF ANY, ARISING BY WAY OF STATE LAW, INCLUDING ANY IMPLIED WARRANTY OF MERCHANTABILITY AND ANY IMPLIED WARRANTY OF FITNESS FOR A PARTICULAR PURPOSE, ARE LIMITED IN DURATION TO THE TERM OF THIS LIMITED WARRANTY AND ARE LIMITED IN SCOPE OF COVERAGE TO THOSE PORTIONS OF THE MOTORHOME COVERED BY THIS LIMITED WARRANTY. WARRANTOR DISCLAIMS ALL IMPLIED AND EXPRESS WARRANTIES, INCLUDING THE IMPLIED WARRANTY OF MERCHANTABILITY AND THE IMPLIED WARRANTY OF FITNESS FOR A PARTICULAR PURPOSE, ON COMPONENTS AND APPLIANCES EXCLUDED FROM COVERAGE AS SET FORTH BELOW. There is no warranty of any nature made by Warrantor beyond that contained in this Limited Warranty. No person has authority to enlarge, amend or modify this Limited Warranty. The dealer is not the Warrantor’s agent but is an independent entity. Warrantor is not responsible for any undertaking, representation or warranty made by any dealer or other person beyond those expressly set forth in this Limited Warranty. Some states do not allow limitations on how long an implied warranty lasts, so the above limitation may not apply to you.

WHAT THE WARRANTY COVERS:

Warrantor’s Limited Warranty covers defects in the manufacture of your motorhome and defects in materials used to manufacture your motorhome. “Defect” means the failure of the motorhome and/or the materials used to assemble the motorhome to conform to Warrantor’s design and manufacturing specification and tolerances. Also see the section “What the Warranty Does Not Cover” set out below.

WHAT WE WILL DO TO CORRECT PROBLEMS:

Warrantor’s sole and exclusive obligation is to repair and/or replace, at its option, any covered defect if: **(1)** you notify Warrantor or one of its authorized servicing dealers of the defect within the warranty coverage period and within five (5) days of discovering the defect; and **(2)** you deliver your Motorhome to Warrantor or Warrantor’s authorized servicing dealer at your cost and expense. It is reasonable to expect some service items to occur during the warranty period. The performance of warranty repairs shall not extend the original warranty coverage period. Further, any performance of repairs after the warranty coverage period has expired or any performance of repairs to component parts and appliances that are excluded from coverage shall be considered “good will” repairs, which shall not alter the express terms of this limited warranty. If the repair or replacement remedy fails to successfully cure a defect after Warrantor received a reasonable opportunity to cure the defect(s), your sole and exclusive remedy shall be limited to Warrantor paying you the cost of having an independent third party perform repair(s) to the defect(s).

Warrantor may use new and/or remanufactured parts and/or components of substantially equal quality to complete any repair.

Defects and/or damage to interior and exterior surfaces, trim, upholstery and other appearance items may occur at the factory during manufacture, during delivery of the motorhome to the selling dealer or on the selling dealer’s lot. Normally, any such defect or damage is detected and corrected at the factory or by the selling dealer during the inspection process performed by the Warrantor and the selling dealer. If, however, you discover any such defect or damage when you take delivery of the motorhome, you must notify your dealer or Warrantor within five days of the date of purchase to have repairs performed to the defect at no cost to you as provided by this Limited Warranty.

If either three or more unsuccessful repair attempts have been made to correct any covered defect that you believe substantially impairs the value, use or safety of your motorhome, or repairs to any covered defect(s) which you believe substantially impairs the value, use or safety of your motorhome have taken 30 or more days to complete, you must, to the extent permitted by law, notify Warrantor directly in writing of the failure to successfully repair the defect(s) so that Warrantor can become directly involved in exercising a final repair attempt for the purpose of performing a successful repair to the identified defect(s).

HOW TO GET SERVICE:

The “Acknowledgement of Receipt of Warranty/Production Information” form must be returned to Warrantor promptly upon purchase to assure proper part replacement and repair of your motorhome. Failure to return the “Acknowledgement of Receipt of Warranty/Production Information” form will not affect your rights under the Limited Warranty so long as you can furnish proof of purchase. For warranty service simply contact one of Warrantor’s authorized service centers for an appointment, then deliver your motorhome (at your expense) to the service center. If you need assistance in locating an authorized warranty service facility, contact Warrantor’s Warranty Department (1-877-466-6226). The mailing address is:

**91320 Coburg Industrial Way
Coburg, Oregon 97408**

In the event the motorhome is inoperative due to malfunction of a warranted part, Warrantor will pay the cost of having the motorhome towed to the nearest authorized repair facility provided you notify Warrantor prior to incurring the towing charges to receive directions to the nearest repair facility.

Because Warrantor does not control the scheduling of service work by its authorized servicing dealers, you may encounter some delay in scheduling and/or in the completion of the repairs.

WHAT THE WARRANTY DOES NOT COVER:

This Limited Warranty does not cover: any motorhome sold or registered outside of the United States or Canada; items which are added or changed after the motorhome leaves Warrantor’s possession; items that are working as designed but which you are unhappy with because of the design; normal wear and usage, such as fading or discoloration of fabrics, or the effects of moisture inside the motorhome; defacing, scratching, dents and chips on any surface or fabric of the motorhome, not caused by Warrantor; owner maintenance, including by way of example wheel alignments and resealing exterior sealant areas; the automotive chassis and power train, including, by way of example the engine, drivetrain, steering and handling, braking, wheel balance, muffler, tires, tubes, batteries and gauges; appliances and components covered by their own manufacturer’s warranty including, by way of example the microwave, refrigerator, ice maker, stove, oven, generator, roof air conditioners, hydraulic jacks, VCR, television(s), water heater, furnace, stereo, radio, compact disc player, washer, dryer, inverter and cellular phone; or flaking, peeling and chips or other defects or damage in or to the exterior or finish caused by rocks or other road hazards, the environment including airborne pollutants, salt, tree sap and hail. Component part and appliance manufacturers issue limited warranties covering those portions of the motorhome not covered by the Limited Warranty issued by Warrantor. To learn more on what specific component parts and appliances are excluded from the Limited Warranty issued by Warrantor please contact your selling dealership or Warrantor directly or review the warranty packet inside the Motorhome.

EVENTS DISCHARGING WARRANTOR FROM OBLIGATION UNDER WARRANTY:

Misuse or neglect, accidents, unauthorized alteration, failure to provide reasonable and necessary maintenance (see Owner’s Manual), damage caused by off road use, collision, fire, theft, vandalism, explosions, overloading in excess of rated capacities, and odometer tampering shall discharge Warrantor from any express or implied warranty obligation to repair any resulting defect.

DISCLAIMER OF CONSEQUENTIAL AND INCIDENTAL DAMAGES:

THE ORIGINAL PURCHASER OF THE MOTORHOME AND ANY PERSON TO WHOM THE MOTORHOME IS TRANSFERRED, AND ANY PERSON WHO IS AN INTENDED OR UNINTENDED USER OR BENEFICIARY OF THE MOTORHOME, SHALL NOT BE ENTITLED TO RECOVER FROM WARRANTOR ANY CONSEQUENTIAL OR INCIDENTAL DAMAGES RESULTING FROM ANY DEFECT IN THE MOTORHOME, INCLUDING BY WAY OF EXAMPLE FUEL AND TRANSPORTATION EXPENSES TO DELIVER THE PRODUCT TO THE SERVICING DEALER, HOTEL ROOMS, LOST WAGES AND MOISTURE DAMAGE SUCH AS MOLD AND MILDEW. THE EXCLUSION OF CONSEQUENTIAL AND INCIDENTAL DAMAGES SHALL BE DEEMED INDEPENDENT OF, AND SHALL SURVIVE, ANY FAILURE OF THE ESSENTIAL PURPOSE OF ANY LIMITED REMEDY. Some states do not allow the exclusion or limitation of consequential or incidental damages, so the above exclusions may not apply to you.

LEGAL REMEDIES:

THIS LIMITED WARRANTY DOES NOT “EXTEND TO FUTURE PERFORMANCE.” ANY ACTION TO ENFORCE THIS LIMITED WARRANTY OR ANY IMPLIED WARRANTIES SHALL NOT BE COMMENCED MORE THAN ONE YEAR AFTER THE EXPIRATION OF THE ONE YEAR WARRANTY COVERAGE PERIOD DESIGNATED ABOVE. IF YOU USE YOUR MOTOR HOME FOR COMMERCIAL OR BUSINESS PURPOSES, ANY ACTION TO ENFORCE THIS LIMITED WARRANTY OR ANY IMPLIED WARRANTIES SHALL NOT BE COMMENCED MORE THAN ONE YEAR AFTER THE EXPIRATION OF THE NINETY (90) DAY WARRANTY COVERAGE PERIOD DESIGNATED ABOVE. THE PERFORMANCE OF REPAIRS SHALL NOT SUSPEND THIS LIMITATIONS PERIOD FROM EXPIRING. Some states do not allow the reduction in the statute of limitations, so the above reduction in the statute of limitations may not apply to you.

THIS WARRANTY GIVES YOU SPECIFIC LEGAL RIGHTS. YOU MAY ALSO HAVE OTHER RIGHTS, WHICH VARY FROM STATE TO STATE.

LARGER PRINT VERSION AVAILABLE WITHIN THE OWNER’S MANUAL AND UPON REQUEST ADDRESSED TO YOUR SELLING DEALER OR WARRANTOR’S WARRANTY DEPARTMENT.

ROADMASTER CHASSIS LIMITED WARRANTY

WHAT THE PERIOD OF COVERAGE IS:

This Limited Warranty provided by Roadmaster® (“Warrantor”) covers your Roadmaster Chassis for thirty-six (36) months from the original retail purchase date or the first 36,000 miles of use, whichever occurs first.

If you use the Roadmaster Chassis that your motorhome is mounted upon for any rental, commercial or business purposes whatsoever, this Limited Warranty covers your new Roadmaster Chassis for Ninety (90) days from the original retail purchase date or the first 24,000 miles of use, whichever occurs first. A conclusive presumption that the Roadmaster Chassis has been used for commercial and/or business purposes arises if you have filed a federal or state tax form claiming any business tax benefit related to your ownership of the motorhome.

This Limited Warranty applies to all owners, including subsequent owners, of the Roadmaster Chassis. However, a subsequent owner must submit a warranty transfer form. A subsequent owner’s warranty coverage period is the remaining balance of the warranty coverage period the prior owner was entitled to under this Limited Warranty. Warranty transfer forms can be obtained by contacting the Customer Relations Department. There is no charge for the transfer.

LIMITATION OF IMPLIED WARRANTIES:

IMPLIED WARRANTIES, IF ANY, ARISING BY WAY OF STATE LAW, INCLUDING ANY IMPLIED WARRANTY OF MERCHANTABILITY AND ANY IMPLIED WARRANTY OF FITNESS FOR A PARTICULAR PURPOSE, ARE LIMITED IN DURATION TO THE TERM OF THIS LIMITED WARRANTY AND ARE LIMITED IN SCOPE OF COVERAGE TO THOSE PORTIONS OF THE MOTORHOME COVERED BY THIS LIMITED WARRANTY. WARRANTOR DISCLAIMS ALL IMPLIED AND EXPRESS WARRANTIES, INCLUDING THE IMPLIED WARRANTY OF MERCHANTABILITY AND THE IMPLIED WARRANTY OF FITNESS FOR A PARTICULAR PURPOSE, ON COMPONENTS AND APPLIANCES EXCLUDED FROM COVERAGE AS SET FORTH BELOW. There is no warranty of any nature made by Warrantor beyond that contained in this Limited Warranty. No person has authority to enlarge, amend or modify this Limited Warranty. The dealer is not the Warrantor’s agent but is an independent entity. Warrantor is not responsible for any undertaking, representation or warranty made by any dealer or other person beyond those expressly set forth in this Limited Warranty. Some states do not allow limitations on how long an implied warranty lasts, so the above limitation may not apply to you.

WHAT THE WARRANTY COVERS:

Warrantor’s Limited Warranty covers defects in the manufacture of the Roadmaster Chassis and defects in materials used to manufacture the Roadmaster Chassis. Defect” means the failure of the Roadmaster Chassis and/or the materials used to assemble the Roadmaster Chassis to conform to Warrantor’s design and manufacturing specification and tolerances. Also see the section “What the Warranty Does Not Cover” set out below.

WHAT WE WILL DO TO CORRECT PROBLEMS:

Warrantor’s sole and exclusive obligation is to repair and/or replace, at its option, any covered defect if: **(1)** you notify Warrantor or one of its authorized servicing dealers of the defect within the warranty coverage period and within five (5) days of discovering the defect; and **(2)** you deliver your Roadmaster Chassis to Warrantor or Warrantor’s authorized servicing dealer at your cost and expense. It is reasonable to expect some service items to occur during the warranty period. The performance of warranty repairs shall not extend the original warranty coverage period. Further, any performance of repairs after the warranty coverage period has expired or any performance of repairs to component parts and appliances that are excluded from coverage shall be considered “good will” repairs, which shall not alter the express terms of this limited warranty. If the repair or replacement remedy fails to successfully cure a defect after Warrantor received a reasonable opportunity to cure the defect(s), your sole and exclusive remedy shall be limited to Warrantor paying you the cost of having an independent third party perform repair(s) to the defect(s).

Warrantor may use new and/or remanufactured parts and/or components of substantially equal quality to complete any repairs.

Defects and/or damage to interior and exterior surfaces, trim, upholstery and other appearance items may occur at the factory during manufacture, during delivery of the motorhome to the selling dealer or on the selling dealer’s lot. Normally, any such defect or damage is detected and corrected at the factory or by the selling dealer during the inspection process performed by the Warrantor and the selling dealer. If, however, you discover any such defect or damage when you take delivery of the motorhome, you must notify your dealer or Warrantor within five days of the date of purchase to have repairs performed to the defect at no cost to you as provided by this Limited Warranty.

If either three or more unsuccessful repair attempts have been made to correct any covered defect that you believe substantially impairs the value, use or safety of your motorhome, or repairs to any covered defect(s) which you believe substantially impairs the value, use or safety of your motorhome have taken 30 or more days to complete, you must, to the extent permitted by law, notify Warrantor directly in writing of the failure to successfully repair the defect(s) so that Warrantor can become directly involved in exercising a final repair attempt for the purpose of performing a successful repair to the identified defect(s).

HOW TO GET SERVICE:

For warranty service simply contact one of Warrantor's authorized service centers for an appointment, then deliver your Roadmaster Chassis (at your expense) to the service center. If you need assistance in locating an authorized warranty service facility, contact Warrantor's Warranty Department (1-877-466-6226). The mailing address is:

**91320 Coburg Industrial Way
Coburg, Oregon 97408**

In the event the Roadmaster Chassis is inoperative due to malfunction of a warranted part, Warrantor will pay the cost of having the motorhome towed to the nearest authorized repair facility provided you notify Warrantor prior to incurring the towing charges to receive directions to the nearest repair facility.

Because Warrantor does not control the scheduling of service work by its authorized servicing dealers, you may encounter some delay in scheduling and/or in the completion of the repairs.

WHAT THE WARRANTY DOES NOT COVER:

This Limited Warranty does not cover: modifications and alterations to the Roadmaster Chassis by others; the motorhome that is mounted upon the Roadmaster Chassis, including by way of example the motorhome manufacturer's design, manufacture, assembly and/or installation of the side walls, roof, windows, flooring, electrical system, plumbing system, LP-Gas system, appliances and slide outs; items that are working as designed but which you are unhappy with because of the design; normal wear and usage; routine maintenance including by way of example wheel alignments; component parts covered by their own manufacturer's warranty, including by way of example the engine, radiator, transmission, tires, tubes, batteries, exhaust system and the emission control systems; and, flaking, peeling rusting and chips or other defects or damage in or to the frame and frame cross members caused by rocks or other road hazards and the environment including airborne pollutants and salt. Component part manufacturers issue limited warranties covering those portions of the Roadmaster Chassis not covered by the Limited Warranty issued by Warrantor. To learn more on what specific component parts are excluded from the Limited Warranty issued by Warrantor please contact your selling dealership or Warrantor directly or review the warranty packet inside the Motorhome.

EVENTS DISCHARGING WARRANTOR FROM OBLIGATION UNDER WARRANTY:

Misuse or neglect, accidents, unauthorized alteration, failure to provide reasonable and necessary maintenance (see Owner's Manual), damage caused by off road use, collision, fire, theft, vandalism, explosions, overloading in excess of rated capacities, and odometer tampering shall discharge Warrantor from any express or implied warranty obligation to repair any resulting defect.

DISCLAIMER OF CONSEQUENTIAL AND INCIDENTAL DAMAGES:

THE ORIGINAL PURCHASER OF THE ROADMASTER CHASSIS AND ANY PERSON TO WHOM THE ROADMASTER CHASSIS IS TRANSFERRED, AND ANY PERSON WHO IS AN INTENDED OR UNINTENDED USER OR BENEFICIARY OF THE ROADMASTER CHASSIS, SHALL NOT BE ENTITLED TO RECOVER FROM WARRANTOR ANY CONSEQUENTIAL OR INCIDENTAL DAMAGES RESULTING FROM ANY DEFECT IN THE ROADMASTER CHASSIS, INCLUDING BY WAY OF EXAMPLE FUEL AND TRANSPORTATION EXPENSES TO DELIVER THE PRODUCT TO THE SERVICING DEALER, HOTEL ROOMS, LOST WAGES AND WATER DAMAGE. THE EXCLUSION OF CONSEQUENTIAL AND INCIDENTAL DAMAGES SHALL BE DEEMED INDEPENDENT OF, AND SHALL SURVIVE, ANY FAILURE OF THE ESSENTIAL PURPOSE OF ANY LIMITED REMEDY. Some states do not allow the exclusion or limitation of consequential or incidental damages, so the above exclusions may not apply to you.

LEGAL REMEDIES:

THIS LIMITED WARRANTY DOES NOT "EXTEND TO FUTURE PERFORMANCE." ANY ACTION TO ENFORCE THIS LIMITED WARRANTY OR ANY IMPLIED WARRANTIES SHALL NOT BE COMMENCED MORE THAN ONE YEAR AFTER THE EXPIRATION OF THE THIRTY-SIX (36) MONTH WARRANTY COVERAGE PERIOD DESIGNATED ABOVE. IF YOU USE YOUR MOTORHOME FOR COMMERCIAL OR BUSINESS PURPOSES, ANY ACTION TO ENFORCE THIS LIMITED WARRANTY OR ANY IMPLIED WARRANTIES SHALL NOT BE COMMENCED MORE THAN ONE YEAR AFTER THE EXPIRATION OF THE NINETY (90) DAY WARRANTY COVERAGE PERIOD DESIGNATED ABOVE. THE PERFORMANCE OF REPAIRS SHALL NOT SUSPEND THIS LIMITATIONS PERIOD FROM EXPIRING. Some states do not allow the reduction in the statute of limitations, so the above reduction in the statute of limitations may not apply to you.

THIS WARRANTY GIVES YOU SPECIFIC LEGAL RIGHTS. YOU MAY ALSO HAVE OTHER RIGHTS, WHICH VARY FROM STATE TO STATE.

LARGER PRINT VERSION AVAILABLE WITHIN THE OWNER'S MANUAL AND UPON REQUEST ADDRESSED TO YOUR SELLING DEALER OR WARRANTOR'S WARRANTY DEPARTMENT.

120705

THE EXECUTIVE 07

SECTIONS

SECTION 1 - GENERAL INFORMATION	3
SECTION 2 - DRIVING & SAFETY.....	17
SECTION 3 - EXTERIOR & INTERIOR CARE	59
SECTION 4 - APPLIANCES	93
SECTION 5 - EQUIPMENT.....	127
SECTION 6 - WATER SYSTEMS	157
SECTION 7 - LP-GAS SYSTEMS.....	179
SECTION 8 - ELECTRICAL SYSTEMS - HOUSE	191
SECTION 9 - ELECTRICAL SYSTEMS - CHASSIS	211
SECTION 10 - CHASSIS INFORMATION	233
INDEX	292

The information contained in this document is intended to reflect standard and optional equipment included in a typically equipped model at the time of delivery to the initial retail owner. Your actual unit may vary from this document as a result of optional equipment that is not generally offered on this model. In the case that you are not the initial retail owner of the unit, this document will not reflect modifications that may have been performed by previous owners.

Product information and specifications are shown herein as of the time of printing. The motorhome manufacturer reserves the right to change product specifications, designs and standard equipment without notice and without incurring obligation.

©Copyright Monaco Coach Corporation. All rights reserved. All other trademarks or registered trademarks are property of their respective holders. Brand name products of other companies mentioned in this manual are not endorsed by the manufacturer of the motorhome.

060055 ATG

THE EXECUTIVE 07

GENERAL INFORMATION – SECTION 1

WARRANTY INFORMATION FILE	5
REPORTING SAFETY DEFECTS.....	5
SAFETY TERMS.....	5
GLOSSARY OF TERMS	6
VENDOR LIST	8
SURVEY	13
LIMITED WARRANTY TRANSFER APPLICATION .	15

WARRANTY INFORMATION FILE

In addition to this Owner's Manual you will find a Warranty Information File in your unit. This file contains valuable documents about your motorhome's systems and equipment. Many of the component manufacturer's warranty registration cards can be found in the box. They will need to be filled out and mailed. Be sure you read and understand all the information in this file to help you safely operate, maintain and troubleshoot those items.

Additional Information:

Changes, additions and supplemental information in the form of Manual Addendums and "Tech Tips" can be obtained by visiting our Web Site at www.monaco-online.com. Select one of the products from the product lineup. Go to the Service menu. A submenu will appear.

It may also be helpful to browse the "Tech Tips" menu for the other product lines. The tips may not completely apply to your particular model but information contained therein can be useful.

REPORTING SAFETY DEFECTS

If you believe that your motorhome has a defect which could cause a crash or could cause injury or death, you should immediately inform the National Highway Traffic Safety Administration (NHTSA) in addition to notifying Monaco Coach. If NHTSA receives similar complaints, it may open an investigation, and if it finds that a safety defect exists in a group of motorhomes, it may order a recall or

remedy campaign. However, NHTSA cannot become involved in individual problems between you, your dealer or Monaco Coach. To contact NHTSA you may call the Auto Safety Hot line toll-free at 1-888-327-4236 (TTY: 1-800-424-9153) (or 1-202-366-0123 in the Washington D.C. area), visit their websites at www.nhtsa.gov or www.safercar.gov, or write to:

NHTSA
U.S. Department of Transportation
400 Seventh Street S.W.
Washington, DC 20590

SAFETY TERMS

Many of the safety terms are personal safety instructions. Definitions for the terms are listed below. It is important to thoroughly read and understand the safety instructions displayed throughout the manual. Failure to comply with specific instructions may result in personal injury or death. Many instructions are required by National Safety Associations.

WARNING:

Warnings contain information regarding personal safety and/or pertaining to potential extensive or permanent damage to the motorhome or its components by means of hazards or improper use.

CAUTION:

Cautions pertain to potential damage to the motorhome and/or its components.

POISON:

A warning or caution pertaining to safety and/or use of a poisonous substance or harmful chemical.

NOTE:

Information and reminders concerning proper operation of the motorhome and/or its components.

INSPECTION:

Inspection of the motorhome and/or its components is required. Additional instruction may follow.

LUBE:

Lubrication, or addition of a lubricant product, to the motorhome and/or a specified component or part is required. Additional instruction may follow.

ASSEMBLE or REPAIR:

Assembly, disassembly or installation of a component or part, and/or repair to the motorhome may be required. Assistance of Technical Support or Technician may be necessary.

INFORMATION:

References to additional information regarding operation of the motorhome and/or its components found in additional sources, other than the Owner's Manual. Also refers to the WARRANTY INFORMATION FILE, found within the Warranty Information Box in the motorhome.

TIP:

Tips contain information, helpful hints and/or suggestion for ease of operation of the motorhome or its components.

GLOSSARY OF TERMS

AC Electricity - Alternating current also known as household power.

AGM Batteries - A type of battery that suspends acid in a special glass mat.

Air Compressor - Pumps air to and builds air pressure in an air system.

Air Dryer - Cools, filters and dries the air delivered by an air compressor.

Air Governor - Controls the operation of the air compressor by constantly monitoring air pressure in the supply tank of the air system. The air governor initiates the unload cycle when the cut-out pressure is reached.

Alternating Current (AC) - A current that varies periodically in magnitude and direction. A battery does not deliver alternating current. Also referred to as shore power, utility power, inverter power, generator power, etc.

Ampere (Amp) - The unit of measure of electron flow rate of current through a circuit.

Ampere-hour (Amp-hr. AH) - A unit of measure for a battery electrical storage capacity, obtained by multiplying the current in amperes by the time in hours of discharge.

Example: A battery which delivers 5 amperes for 20 hours, delivers 5 amperes times 20 hours, or 100 Amp-Hr. of capacity.

ANSI - American National Standards Institute.

ASTM - American Society for Testing and Materials.

Black Water - Term associated with the sewage holding tank. The toilet drains directly into this tank.

CCA - Cold Cranking Amperage is the amount of current a battery can deliver for 30 seconds at 0° F without dropping below a specified voltage, usually 10.5 Volts DC.

Chassis Battery - Powers chassis 12 Volt accessories and starts engine.

Circuit - An electric circuit is the path of an electric current. A closed circuit has a complete path. An open circuit has a broken or disconnected path.

City Water - A term associated with the water supply that you hook-up to at campgrounds. It is called city water because water is pulled from a central source (like in a city) and not the fresh water tank.

Compressor Load Cycle - The time during which the air compressor is building pressure.

Compressor Unload Cycle - The time during which the air compressor is idling and is not building air pressure.

Curbside - This refers to the side of the motorhome which faces the curb when it is parked. Often called the door side or the passenger side.

Current - The rate of flow of electricity or the movement rate of electrons along a conductor. It is comparable to the flow of a stream of water. The unit of measure for current is the ampere.

Cut-In Pressure - The pressure level in the air system supply tank which triggers the compressor load cycle. May apply to some water systems, such as water pump, accumulator tank, etc.

Cut-Out Pressure - The pressure level in the air system supply tank which triggers the compressor unload cycle. May apply to some water systems, such as water pump, accumulator tank, etc.

Cycle - In a battery, one discharge plus one recharge equals one cycle.

Desiccant - A granular substance that has a high affinity for water and is used to retain moisture from the air stream flowing through the air dryer cartridge.

Direct Current (DC) - Power that is stored in a battery bank or supplied by photovoltaics, alternator, chargers and DC generators. Direct current is also known as battery power. Current only flows one way.

Drain Trap - This is a curve that is in all drains. Water is trapped in the curve and this creates a barrier so tank odors cannot escape through the drain.

Dry Camping - Camping in the motorhome when there is no city water hook-up or shore power. In other words, using only the water and power that is in the motorhome and not from another source.

Drying Cycle - The time during which the air dryer cools, filters and removes moisture from the air delivered by the air compressor. The drying cycle begins and ends the same as the compressor load cycle.

Dump Station - A site where the waste (grey) and sewage (black) tanks can be drained. In most states it is illegal to drain waste tanks anywhere other than at a dump station.

Dump Valve - Another name for the T-handle valve used to drain the sewage (black) and waste (grey) tanks.

Escape (Egress) Window - The formal name for the emergency window located in the rear of the motorhome. Egress windows can be easily identified by their red handles.

Full Hook-Up Site - A campground that has city water, shore power and sewer hook-ups or connections available.

Grey Water - Term associated with the waste water holding tank. Water from the sink drains, the shower and the washer-dryer (if equipped) go into this tank.

House Battery - Powers 12 Volt DC lights and accessories inside motorhome.

LED (Light Emitting Diode) - Indicator light.

Low Point Drain - The lowest point in the plumbing. Drains are placed here so that water will drain out of the lower end of the motorhome. These drains must be closed when you fill the water tank.

OEM - Term for Original Equipment Manufacturer.

OHM - A unit for measuring electrical resistances.

Ohm's Law - Expresses the relationship between Volt (E), amperes (I) in an electrical circuit with resistance (R). It can be expressed as follows: $E = IR$. If any two of the three values are known, the third value can be calculated by using the above formula.

Potentiometer - A device for measuring an unknown potential difference or electromotive force.

Pounds Per Square Inch Gauge (psig) - Pressure measured with respect to that of the atmosphere. This is a pressure gauge reading in which the gauge is adjusted to read zero at the surrounding atmospheric pressure. It is commonly called gauge pressure.

Purge - The initial blast of air (decompression) from the air dryer purge valve at the beginning of the air compressor.

Purge Cycle - The time during which the air dryer is undergoing purge and regeneration. This cycle starts at the beginning of the compressor unload cycle and normally ends well before the beginning of the compressor load cycle.

Regeneration - The mild backflow of air through the air dryer and out the purge valve that begins immediately after the purge and lasts normally 10 to 15 seconds. This backflow of air, from the air system and through the air dryer, removes moisture from the desiccant cartridge and prepares the air dryer for the next compressor load cycle.

Roadside - This refers to the side of the motorhome which faces the road when it is parked. Often called the off-door side or the driver side.

SCA - Term for Supplemental Coolant Additive. Chemical added to coolant for diesel engines to help prevent cylinder liner pitting and internal corrosion.

Shore Line - This is the electrical cord which runs from the motorhome to the campground 120 Volt AC electrical supply.

Shore Line Plug - The 120/240 Volt AC outlet allows the motorhome to be hooked up to a campground facility.

Stinger - An arm attachment on a tow truck that is used to lift the motorhome slightly so that it can be towed.

Volt - The unit of measure for electric potential.

Watt - The unit for measuring electrical power, i.e. the rate of doing work, in moving electrons by or against an electric potential.

Wet Cell Battery - A type of battery that uses liquid as an electrolyte. This type of battery requires periodic maintenance such as cleaning the connections and checking the electrolyte level.

VENDOR LIST

Air Springs
Contitech
800-654-0974
www.contitech-usa.com

Air Conditioner - Dash
SCS/Frigette
800-275-7524
www.scsfrigette.com

Air Conditioner - Roof
Dometic Corp.
800-544-4881
www.dometic.com

Air Filter
Donaldson
952-887-3131
www.donaldson.com

Air Mattress (Optional)
Select Comfort
888-590-9237
www.selectcomfort.com

Aladdin™
Monaco Coach Corporation
Technical Support
877-466-6226

Alternator
Leece-Neville
800-354-0560
www.prestolite.com

Aqua-Hot
Vehicle Systems Inc.
800-685-4298
www.hydro-hot.com

Awnings
Carefree
303-469-3324
www.carefreeofcolorado.com

Girard Systems
800-382-8442
www.girardrv.com

Axles - Brakes
Eaton Corporation
800-826-4357
www.truck.eaton.com

Batteries
Interstate
800-772-3600
www.interstatebatteries.com

Battery Isolator
Intellitec
800-251-2408
www.intellitecsve.com

Brakes-Anti-Lock Brake System

Eaton
800-826-4357
www.truck.eaton.com

Brakes-Automatic Traction Control

Eaton
800-826-4357
www.truck.eaton.com

Carbon Monoxide Detector

Safe-T-Alert
800-383-0269
www.safe-t-alert.com

Citizen Band Radio (Optional)

Cobra
733-889-3087
www.cobraelec.com

Collision Warning System (Optional)

Eaton/Vorad
866-788-6723
www.vorad.com

Cockpit Seats

Villa
888-707-7272
www.villainternational.com

Cooktop

Kitchenaid (LP-Gas)
800-422-1230
www.kitchenaid.com

Dash Radio

Kenwood
800-536-4663
www.kenwoodusa.com

Dishwasher (Optional)

Fisher/Paykel
888-936-7872
www.usa.fisherpaykel.com

Dumping System (Optional)

RV Sani-Con
866-410-1965
www.emptythetanks.com

DVD Player

Sony
800-222-7669
www.sony.com

DVD - Bedroom

Kenwood
800-536-4663
www.kenwoodusa.com

Engine

Cummins
800-343-7357
www.cummins.com

Detroit (Optional)

800-445-1980
www.detroitdiesel.com

Engine Brake

Jacobs
888-243-1441
www.jakebrake.com

Entry Step

Kwikkee
800-736-9961
www.kwikkee.com

Fan - Bathroom Exhaust

Fan-Tastic Vent
800-521-0298
www.fantasticvent.com

Faucet

Moen
800-289-6636
www.moen.com

Filters - Coolant, Fuel, Oil

Fleetguard
800-223-4583
800-22Filter
www.fleetguard.com

Detroit (Optional)

800-445-1980
www.detroitdiesel.com

Racor Fluid Filters

800-344-3286
www.parker.com/racor/

Gar-Ber Filters

206-789-2758
www.garberfilters.com

Fire Extinguisher

Kidde
800-880-6788
www.kiddesafety.com

Generator

Onan
800-888-6626
www.onan.com

Home Theater

Sony
800-222-7669
www.sony.com

Insta-hot (Optional)

Insinkerator
800-558-5700
www.insinkerator.com

Inverter

Magnum
305-386-5125
www.magnumenergy.com

Keyless Entry

Trimark
800-447-0343
www.trimarkcorp.com

Leveling System - Air

Valid Manufacturing
250-832-6477
www.validmanufacturing.com

Leveling Jacks - Hydraulic (Optional)

Power Gear
800-334-4712
www.powergearus.com

LP-Gas Detector

MTI Industries, Inc.
800-383-0269
www.mtiindustries.com

LP-Gas Tank

Manchester
800-877-8265
www.mantank.com

Manabloc Water Manifold

Vanguard Pipe
800-775-5039
www.vanguardpipe.com

Microwave

Sharp Electronics Corp.
800-237-4277
www.sharp-usa.com

Navigation System

Kenwood
800-536-9663
www.kenwoodusa.com

Outside Mirrors

Velvac Mirror
800-783-8871
www.velvac.com

Power Cord Reel

Glendinning Marine
843-399-6146
www.glendinningprods.com

Power Hose Reel

Glendinning Marine
843-399-6146
www.glendinningprods.com

Power Sun Visors

Carefree of Colorado
303-469-3324
www.carefreeofcolorado.com

Radio-Bedroom

Bose
800-905-2138
www.bose.com

Rear Vision System

Kenwood
800-536-9663
www.kenwoodusa.com

See-Vision

Infinite Innovations
800-545-9633
www.infiniteinnovations.com

Refrigerator

Norcold
800-543-1219
www.norcold.com

Refrigerator -Residential (Optional)

Maytag
800-688-9900
www.maytag.com

Safe (Optional)

Stealth Safe Company
800-248-7233

Satellite Radio (Optional)

Sirius
888-539-7474
www.siriusradio.com

XM
800-967-2346
www.xmradio.com

Satellite Receiver

Hughes
800-347-3292
www.hughes.com

Satellite System

Kingdome
800-982-9920
www.kingcontrols.com

Security System (Optional)

Magnadyne
800-638-3600
www.magnadyne.com

Shock Absorbers

Bilstein
800-537-1085
www.bilstein.com

Slide-Out Motor - Electric

Lippert Components
866-524-7821
www.lippertcomponents.com

Slide-out Motor - Hydraulic

HWH Corporation
800-321-3494
www.hwhcorp.com

Lippert Components
866-524-7821
www.lippertcomponents.com

Solar Panels (Optional)

RV Solar Consultants
541-937-9812
www.amsolar.com

Steering Gear

TRW
765-423-5377
www.trw.com

Steering Wheel (Smart Wheel)

Vehicle Improvement Products
847-395-7250
www.vipwheels.com

Storage Trays

Kwikkee
800-736-9961
www.kwikkee.com

Television - LCD

Sharp
800-237-4277
www.sharp-usa.com

Television Antenna

Winegard
800-288-8094
www.winegard.com

Tires

Goodyear Tire & Rubber
800-321-2136
www.goodyear.com

Toilet

Sealand
800-321-9886
www.sealandtechnology.com

Transfer Switch

Surge Guard
800-780-4324
www.surgeguard.com

Transmission

Allison Transmission
800-524-2303
www.allisontransmission.com

Vacuum (Optional)

Eureka
800-282-2886
www.eureka.com

Washer/Dryer (Optional)

Splendide
800-356-0766 ext. 5
www.splendide.com

Bosch

800-921-9622
www.boschappliances.com

Water Filters

Premier (Service Bay)
800-752-5582
www.premierh2o.com

Ozone Technologies (Galley)
920-863-2444
www.trupure.com

Water Filter (Bay)

Watts Premier
800-774-7405
www.wattspurewater.com

Water Pump

Aquatec
800-975-9995
www.aquatec.com

Wheels - Accushield

Accuride
812-962-5000
www accuridewheels.com

Windshield Wipers

Diesel Equipment
800-632-4959
www.diesequipment.com

Universal Remote

Logitech/Harmony
702-269-3457
www.logitech.com

OWNER'S MANUAL SURVEY: The Executive 2007

Your suggestions are very important to us and we are continually striving to improve the quality of our manuals. After becoming familiar with your new recreational vehicle and the accompanying manual, please take the time to answer the following questions. When you are finished please return the survey via mail to our Technical Publications Department, or you may fax the survey to: **(541) 681-8031 Attention: Technical Publications Department**. Feel free to attach an additional page if you desire.

1. Is this your first recreational vehicle? YES / NO (circle one)

2. If no, what was your previous recreational vehicle brand/model? _____

3. Was the overall appearance and lay-out of this manual what you expected to see in your new recreational vehicle?

4. Was the information within this manual helpful in acquainting you with your new recreational vehicle? If not please address any area(s) we need to expand or improve on.

5. Were the operating instructions clearly written, and were you able to follow the steps without any difficulty?

6. Is there any additional information you would like to see incorporated within the owner's manual?

NAME: _____

PHONE: (____) _____

ADDRESS: _____

SERIAL # _____

TEAR OFF PAGE AND MAIL TO:

TECHNICAL PUBLICATIONS PLT. 17
MONACO COACH CORPORATION
91320 COBURG INDUSTRIAL WAY
COBURG, OR 97408

LIMITED WARRANTY TRANSFER APPLICATION/CHANGE OF OWNER INFORMATION

Mail to:

**Monaco Coach Corporation
Warranty Transfer
91320 Coburg Industrial Way
Coburg, OR 97408**

Please read terms and representations below before signing.

Submitted By:

Name: _____

Address: _____

City: _____ State: _____ Zip: _____

Phone: (_____) _____

Limited Warranty Transfer

Address Change

A. Current Owner Information:

First Name Initial Last Name

Vehicle Identification Number Unit # (15 digits) (6 digits) Model/Year

B. New Owner Information, Transfer Coverage To:

First Name Initial Last Name

(_____)
Phone Number Street Address City State Zip

Date of Transfer (If Applicable) Odometer Reading at Transfer (If Applicable)

C. Signatures:

(New) Owner's Signature Date Selling Dealer's Signature (If Applicable) Date

Terms & Representations

By your signature(s) on face side of this form, and in order to induce Monaco Coach Corporation to transfer its Limited Warranty, you represent the following:

1. That you have received and read a copy of the Limited Warranty.
2. You understand that the unit is to be used only for family camping and cross country travel on improved roads.

3. All information provided by you on face side of this form is true and correct.
4. You understand that you are purchasing a pre-owned recreational vehicle and Monaco Coach Corporation does not make any representation as to its present condition.

TEAR OFF PAGE AND MAIL TO:

WARRANTY TRANSFER, MONACO COACH CORPORATION,
91320 COBURG INDUSTRIAL WAY
COBURG, OR 97408

THE EXECUTIVE 07

DRIVING & SAFETY – SECTION 2

DRIVING & SAFETY	18	WEIGHING THE MOTORHOME	42
Inspections	18	Weight Terms	42
Familiarize Yourself.....	18	Weight Label	45
Mirror Adjust.....	18	Six-Point Weighing Example	46
Safety Seat Belts	18	Cargo Carrying Capacity Flowchart	48
DRIVING TIPS	20	Weighing Procedure Worksheet	49
TRIP PREPARATION	23	Weight Record Sheet.....	50
HITCH	24	VORAD SAFETY SYSTEM (OPT)	50
Using the Rear Receiver	24	Side Sensors Display	51
REAR VIEW SYSTEM	26	VORAD Driver Display	51
BACKING UP A MOTORHOME	27	SmartCruise® - Operation	51
SET-UP PROCEDURES	29	Special Situations.....	52
DRY CAMPING	30	SECURITY SYSTEM (OPT)	52
BREAKING CAMP	31	Basic Operations	52
EMERGENCY ROADSIDE PROCEDURES	32	System Override	53
In Case of Flat Tire	33	SAFE (OPT)	53
Engine Light - Retractable.....	33	SMOKE DETECTOR	53
Dead Chassis Battery	33	Operation	54
TOWING PROCEDURES	35	Testing.....	54
Disabling Parking Brake.....	36	Maintenance	54
TIRES	36	Troubleshooting	54
Importance of Air Pressure.....	37	CARBON MONOXIDE DETECTOR	54
Tire Pressure Inflation Guideline.....	37	Operation	55
Tire Chart - Goodyear.....	38	Alarm.....	55
Inspecting & Pressure	39	Testing.....	56
Air Pressure Checklist	39	Cleaning & Maintenance.....	56
Supporting When Leveling.....	40	FIRE EXTINGUISHER	56
Tire Vibration.....	40	ESCAPE (EGRESS) WINDOW	57
Tire Rotation	41		
Tread	41		
Storage of Tires - Long Term	41		
WHEEL MOUNTING	41		

DRIVING & SAFETY

Section Two contains information on driving tips, emergency situations, towing, safety devices, weighing the motorhome and tires.

NOTE:

The motorhome has an electronic data recording device that may record information about direction, road speed, engine speed, brake application, steering attitude or other vehicle operating data. Data recording devices can be present in engines, transmissions, ABS (Antilock Brake Systems) or other systems affiliated with operation of the vehicle. Information from data recording devices can be examined in case of an accident. Contact the component manufacturer to learn more about these devices.

Inspections

There are significant differences between a passenger automobile and a motorhome. Always be aware of these differences when traveling. The key to safely operating a motorhome is **inspection**. Undetected problems could cause problems on the road and may result in lost time and increased repair costs. Several states require a special license endorsement and that the motorhome be inspected prior to registration. Know and observe the laws of the states in which you will be traveling. Laws may vary from state to state. A systematic **inspection** conducted prior to moving the motorhome can help ensure nothing is overlooked and will assist in familiarizing the owner with the motorhome. Prior to moving the motorhome perform a

general **inspection**, which includes examining the condition of the motorhome and the surrounding area of the motorhome. Look high and low when walking around the motorhome.

Familiarize Yourself

Because the location of the driver's seat in the motorhome is higher and farther to the left than most vehicles, a different perspective of the roadway is created. Rely on the outside mirrors to line up with the center of the road and to check conditions behind the motorhome. The dashboard may include more gauges and controls than are normally found in passenger automobiles. Become familiar with these gauges and their indications before starting out.

Mirror Adjust

Prior to starting out, adjust the mirrors. It is recommended that an assistant help to simplify the mirror adjustment process.

Mirror Adjusting:

- ◆ Adjust the driver seat to travel position.
- ◆ Use a flat-head screwdriver to remove screw caps at points **A** and **B**.

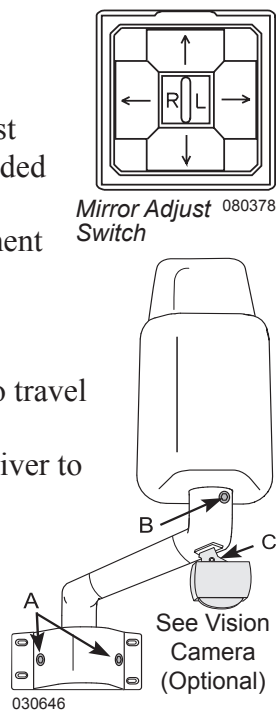

- ◆ Using a 3/16" Allen wrench, have the assistant loosen the two 3/16" set screws located at the base of the mirror (see A on illustration).
- ◆ Adjust the mirror for a clear side view of the motorhome.
- ◆ Tighten the two base screws once proper adjustment is made.
- ◆ Use a 3/32" Allen wrench to loosen the optional camera (**C** on illustration). Adjust the camera angle and retighten.
- ◆ To adjust the head of the mirror, loosen the 3/16" set screw located at point **B**. Adjust to the left or right.
- ◆ Ensure all the set screws are tight.
- ◆ Adjust the mirrors by using the Mirror Select switch to select the appropriate mirror and Mirror Adjust to fine tune the view.

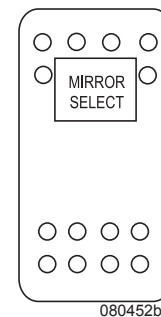

Safety Seat Belts

All occupants must be furnished with and use seat belts while the motorhome is moving. The driver's seat, and all other seats designed to carry passengers while the motorhome is in motion, are equipped with safety seat belts. **DO NOT** occupy beds or seats that are not equipped with a safety belt while the motorhome is in motion. The driver's seat must be locked in the forward facing position while motorhome is in motion. **DO NOT** use a seat belt on more than one person.

To fasten the seat belt, pull the belt out of the retractors and insert the tab into the buckle; a click will sound when the tab locks into the buckle. Seat belt lengths automatically adjust to your size and sitting position. **DO NOT** route belts over armrest.

WARNING:

Safety belts are supplied at affixed seating positions. **DO NOT** occupy seats not equipped with safety belts while the motorhome is in motion. Seat belts must only be used on permanently mounted seats. **DO NOT** use a single seat belt on more than one person. Pilot and Co-pilot seats must be locked in a forward facing position with seat belts fastened while the motorhome is in motion. Avoid seat rotation while in transit.

Child Safety Seat:

Children that fit into *Example 1* and *Example 2* require the use of a child safety seat. In the motorhome, the child safety seat can be positioned in two places: the front passenger (co-pilot) seat and the forward facing permanently mounted booth dinette seat.

WARNING:

Only forward facing booth dinette seats equipped with seat belts are designed for occupancy while the motorhome is in motion.

WARNING:

Children must not be transported unrestrained. Infants must be placed in approved safety seats. Small children must be restrained in child safety seats. **DO NOT** use a single seat belt on more than one child. Failure to comply with these rules can lead to injury or death.

NOTE:

Individual states and Canadian provinces may have laws that can exceed the requirements described above. It is your obligation to know and comply with the laws in the state or province in which you travel.

A child safety seat is required for any child:

- ◆ **Infants** - from birth to one year, or up to 21 pounds, the child is considered an infant. A (convertible) safety seat for an infant must be secured facing to the rear. The top of the head must be below the top of the safety seat. Secure safety seat harness straps at or below the shoulders (*Example 1*).
- ◆ **Toddlers** - Children over one year and between 20-40 pounds are considered toddlers. A (convertible) safety seat for a child must be secured facing forward. The top of the head must be below the top of the safety seat. Secure safety seat harness straps at or below the shoulders (*Example 2*). Most seats require a top slot for facing forward.
- ◆ **Young Children** - Children (ages four to eight) over 40 pounds and under 4' 9" require a booster seat. The booster seat places the child's waist and shoulders at the proper height for the supplied safety belt to be effective. The top of the head must be below the top of the safety seat (*Example 2*).

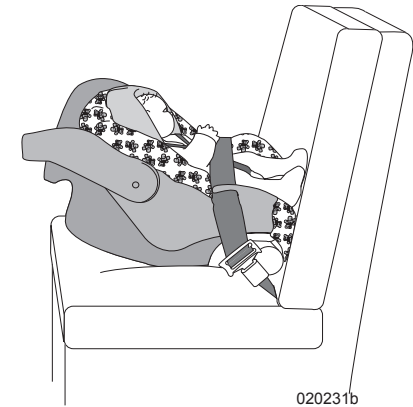

Example 1: Convertible seat facing to the rear.



Example 2: High back booster seat facing forward.

WARNING:

Installation illustrations are for reference only, and are not to be used as a guide. Because there are many styles of safety and booster seats, refer to the safety seat manufacturer's manual for proper installation and how to properly install and secure the safety or booster seat.

NOTE:

Individual states and Canadian provinces may prohibit use of a safety or booster seat in the front seat.

Seat Belt Care:

Keep the belt clean and dry. Clean with mild soap and lukewarm water. **DO NOT** clean seat belts with bleach, dye or abrasive cleansers that may weaken the belt material. Periodically **inspect** belts for cuts, frays or loose parts, and replace damaged parts. **DO NOT** disassemble or modify the system. Replace the seat belt assembly after a severe impact, even when damage is not obvious.

DRIVING TIPS

The motorhome is a complex vehicle that requires increased driving awareness because of its size and various components. Due to the motorhome length the turning radius will be much wider than that of a standard automobile. Always pay close attention to the perimeter of the motorhome including front, sides, rear, roof and undercarriage. Ensure the surrounding area is clear of obstacles. Utilize the driving mirrors to observe traffic conditions as well as the motorhome exterior including tires, bay doors, blind spots, etc. Use a push-pull method of steering, with both hands parallel on the steering wheel.

The motorhome is also heavier than an automobile and has a higher center of gravity. These factors affect the reaction time of the motorhome. Swerving and sharp turning, especially performed at high speeds, could result in loss of control of the motorhome. Keep the size of the motorhome in mind and drive with extra caution to avoid situations which might require quick momentum changes. Increase reaction time by paying attention to traffic and

road conditions 12 to 15 seconds ahead of the motorhome's position.

The motorhome will travel safely and comfortably at highway speed limits. However, it takes more time to reach highway speed. When passing another vehicle, allow extra time and space to complete the pass due to the added length of the motorhome.



When descending a long hill, manually shift to a lower gear and begin the descent at a slow speed. **DO NOT** allow the motorhome to gain momentum before trying to slow down. Use the engine brake in conjunction with the service brakes to help maintain a safe, slow descent. The transmission and engine will help control downhill speed and can extend the service life of the brake lining. Distance required to stop the motorhome is greater than an automobile. Practice stopping away from traffic to get the “feel” of distance required to stop the motorhome.

Check tonnage limits of bridges before crossing to ensure they can support the weight of the motorhome. Signs should be posted at bridge entrances. Check the posted height of all overpasses or situations where overhead clearance is limited. Keep in mind that road surfaces may be repaved or packed with snow; therefore, the actual posted clearance height would not apply in such conditions.

Driving Cautions:

- ◆ Avoid getting too close to the shoulder of the road, which may be too soft to support the weight of the motorhome.
- ◆ Side spacing is best maintained by keeping the motorhome centered in the driving lane.
- ◆ Driving lanes in work zones can be uneven, congested and narrower than usual.
- ◆ Be cautious of road debris that can damage the undercarriage of the motorhome or become lodged in the dual tires and cause damage to the tires, wheel rims or tow vehicle.
- ◆ On back roads and single divided roads, tree branches and shrubbery can protrude into the roadway. Watch for low hanging branches especially during inclement weather as rain and snow will cause branches to hang lower than usual.
- ◆ Keep in consideration that posted speed signs are usually passenger automobile rated. Be extra aware of driving conditions and use the appropriate speed for a motorhome when necessary, especially on corners and mountain roads.
- ◆ Downgrade speed should be at least 5 mph less than upgrade speed, or downgrade speed should be attainable within three seconds of a brake application.
- ◆ Use a four second rule when following other vehicles at speeds under 40 mph. Use a five second rule when following at speeds over 40 mph.

Right Turns:

Negotiating a right hand turn in a motorhome can be difficult. Many drivers fear they cannot make the turn without entering into the other lane or jumping the curb. Here are a few tips to make a right hand turn easier:

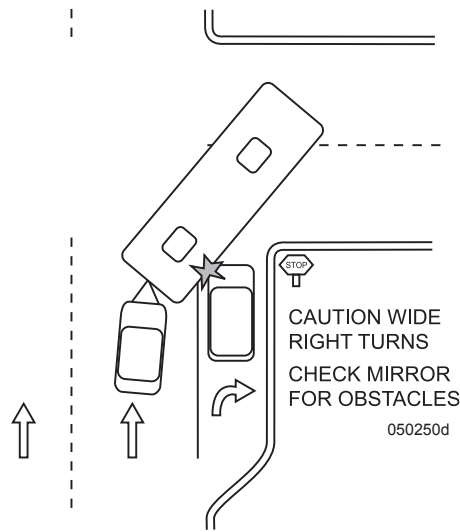

- ◆ As the turn approaches, look into the mirror to ensure the lane to the left is clear, then move wide over to the left.
- ◆ When making the right turn, the left rear wheel should touch the center line of the road and the driver's hips should be parallel to the roadside curb of the corner being turned to aid in avoiding a premature turn.
- ◆ Make the turn slowly.
- ◆ Check mirrors frequently. Stay aware of necessary clearance and space management of the motorhome while negotiating the turn.

Left Turns:

◆ **DO NOT** start the turn until the center of the intersection is reached with your hips. If there are two lanes available, take the right hand lane. A car or driver on the left hand side is easier seen.

Ascending a Grade:

When approaching an uphill grade, assess the grade and length before beginning the climb. Prepare early for long climbs. Unlike gasoline engines, diesels do not necessarily produce more power by pressing further on the accelerator! A gasoline engine will happily work at full throttle (at least for a short period of time), but a diesel usually just wastes fuel at full throttle. The power output from a diesel engine is dependent upon the following:

- ◆ **RPM** - Every engine has a range of RPM that produces power most efficiently.
- ◆ **Fuel/Air mixture** - At a given RPM, the engine, even with the help of a turbo-charger, can only “pump” a given volume of air into the combustion chamber. This volume of air can efficiently combine with only so much fuel; so it follows logically that feeding more fuel to the fire will simply waste fuel.

Determine ranges where the motorhome works best by driving long grades when temperatures remain stable for the duration of the climb.

IMPORTANT SAFETY TIP:

Turn on the four way flashers if road speed degrades to the point where the motorhome is moving significantly under the posted speed. Use pullouts if traffic is building. Once in a pullout, if there is sufficient clearance for safety, idle the engine for a while to allow the exhaust and the turbo to cool. While these are cooling, the transmission will also cool. Monitor the gauges while waiting.

Descending a Grade:

Prepare to descend a grade at the crest of the hill. Observe any signs indicating grade angle and duration. The sign may suggest maximum downhill speed according to Gross Combined Weight (the combined weight of the motorhome and a trailer/tow car). At the crest of the hill, manually shift the transmission into a lower gear. **DO NOT** allow the motorhome to gain momentum before slowing down.

Use the engine brake to help maintain a slow, safe downhill speed. Located on the Driver Side console is an engine brake switch. When the engine brake switch is on, the engine brake will activate when the throttle is released. The brake switch sets the amount of engine braking force. When pushed forward, the engine brake will use all six cylinders. When pushed back, only three cylinders are used.

With engine brake applied, road speed may increase until the transmission automatically shifts to the next higher gear. Apply the brakes using moderately heavy pressure on the brake pedal to reduce speed and manually downshift to maintain a safe, slow speed. **DO NOT** pump the brakes as this can result in a loss of air pressure. Avoid riding the brakes as this can cause the brakes to overheat. Either method can result in loss of brake effectiveness or brake failure.

Night Driving:

- ◆ Be well rested and alert while driving. If necessary, find a safe stopping place to rest until ready to continue.
- ◆ Avoid using interior lights while driving that create a glare on the windshield and decrease visibility.
- ◆ Dim dash lights to a comfortable level to reduce glare.

Extreme Heat and Hot Weather Conditions:

- ◆ Frequently observe all gauges. Variations from normal conditions should be promptly evaluated.
- ◆ Check tire pressure before traveling in hot conditions. Tire air pressure increases with heat. **DO NOT** let air out of a hot tire. When the tires cool down they will return to the correct/previous tire pressure.
- ◆ Pay extra attention to hoses and belts that are more susceptible to fatigue in extreme heat.

Winter and Cold Climate Conditions:

- ◆ The motorhome should be prepared for Cold Weather Use.
- ◆ Keep speeds slow and steady. Make moves gradually and increase visual distance for a gain in reaction time.
- ◆ If road or weather conditions are treacherous find a safe stopping place and wait for conditions to improve.
- ◆ Avoid using an engine braking device on wet or slippery surfaces, which can cause the drive wheels to skid.
- ◆ Wiper blades should be in good condition. Fill the washer reservoir with antifreeze formula window washer fluid.
- ◆ Use mirror heat to keep mirrors clear.
- ◆ Remove any ice build-up from the entry step to avoid accidental slipping.

Wet Conditions:

- ◆ Worn or improperly inflated tires can increase the risk of hydroplaning.
- ◆ Heavy rain or deep standing water can cause brakes to apply unevenly or grab.

Refueling:

- ◆ Truck stops are good refueling points for motorhomes.
- ◆ Check overhead clearance heights before pulling through the fuel island.
- ◆ Be aware of concrete/steel posts installed around fuel islands.
- ◆ Avoid running over the fuel hose as it can get hung up on the motorhome and cause body damage.
- ◆ Use of gloves is recommended for refueling. Store gloves in the outside compartment.

- ◆ To prevent grease and fuel deposits from being tracked into the motorhome when refueling, change shoes before entering. Store the extra pair of shoes near the entry door.

WARNING:

LP-Gas and gasoline are highly flammable and can ignite, resulting in explosion, fire or death. Ensure all flames are extinguished, all LP-Gas appliances are turned off and the primary LP-Gas valve is off prior to refueling.

Fuel Economy:

Driving style, wind resistance, terrain, vehicle weight, and engine-driven accessories are some of the factors that affect fuel economy.

Guidelines to Help Increase Fuel Efficiency:

- ◆ When starting out, apply the throttle lightly and accelerate gradually. Avoid using excessive throttle and accelerating quickly.
- ◆ Check the tire pressure. A low tire is not only a safety hazard, but also increases rolling resistance, which increases fuel consumption.
- ◆ Keep the engine at a low to mid operating range of 1100 to 1500 RPM. This will use less fuel than operating at higher RPM.
- ◆ Avoid using full throttle when ascending a long hill. This wastes fuel and increases engine operating temperature from incomplete combustion. Manually shift to a lower gear and use less throttle. Fuel will burn more efficiently.

- ◆ Avoid extended idling to warm-up the engine. Start the engine and wait for normal oil pressure to register. Engage the high idle feature until the engine coolant temperature gauge raises. The engine is now ready for travel. Whenever coolant temperature is below 160° F (idling engine) incomplete combustion occurs, causing carbon build-up and raw fuel to wash lubricating oil from the cylinder walls and dilute the crankcase oil.
- ◆ Excessive idling (more than 10 or 15 minutes) can clog fuel injectors, eventually causing piston rings and valves to stick.
- ◆ Operate the transmission with the **MODE** function set to Economy whenever possible; this allows for earlier shifts and enhanced fuel economy.
- ◆ Follow the maintenance schedule for the engine.

TRIP PREPARATION

The following suggestions are general guidelines to follow when preparing for a trip:

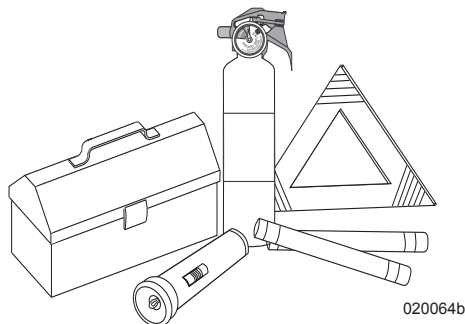

020064b
Tool Box & Emergency Road Supplies

Items to Carry:

- ◆ An emergency road kit containing a flashlight, road flares, warning signs and a fire extinguisher.
- ◆ Local, State and National Maps, as well as a 'Motor Carrier' road atlas (for refueling station and truck repair facility locations).
- ◆ Hand tools, a 12 Volt DC test light, a 120 Volt AC polarity tester, battery hydrometer, an assortment of blade fuses and alternator belt.
- ◆ Potable and non-potable water hoses, a water pressure regulator and various termination connectors for sewage.

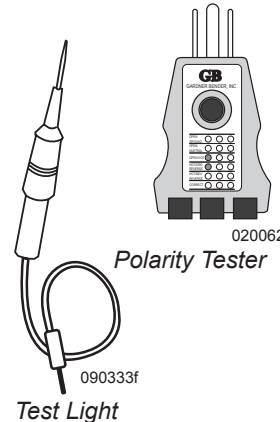

Inspection:

- ◆ Ensure all exterior items are stowed or secured (i.e. TV antenna, ceiling vents and windows).
- ◆ Check belts, hoses, battery and engine fluid levels. **Inspect** the engine, transmission and generator per the OEM manuals.
- ◆ Evenly distribute and secure cargo. Store heavy items near the rear axle and lighter items toward the front to prevent uneven stress and handling problems.

- ◆ Check all tires outside the motorhome for accurate pressure and physical condition. Look around, above and under the motorhome for obstruction or leaks. Test all exterior lighting: headlamps, taillights, brake and clearance lights.
- ◆ Inside the motorhome store and secure heavier objects in the lower cabinets to maintain a low center of gravity for sway reduction. Secure loose items to prevent weight shifts. Store lighter items in the overhead cabinets. Close and secure all cabinet doors and drawers, shower and pocket doors. Turn off interior lighting. Adjust exterior mirrors and check dash gauges for proper operation.

INFORMATION:

For chassis maintenance details refer to the chassis section.

CAUTION:

Open the bay doors slowly after a trip as cargo may shift during travel.

WARNING:

To avoid injury, never place hands or fingers near the edges of the bay door when opening or closing. Always use the latch handle. Apply pressure with the other hand just above the latch handle.

TIPS:

Multi-purpose items, versatile clothing and periodic removal of unused cargo will streamline cargo storage.

HITCH

Using the Rear Receiver

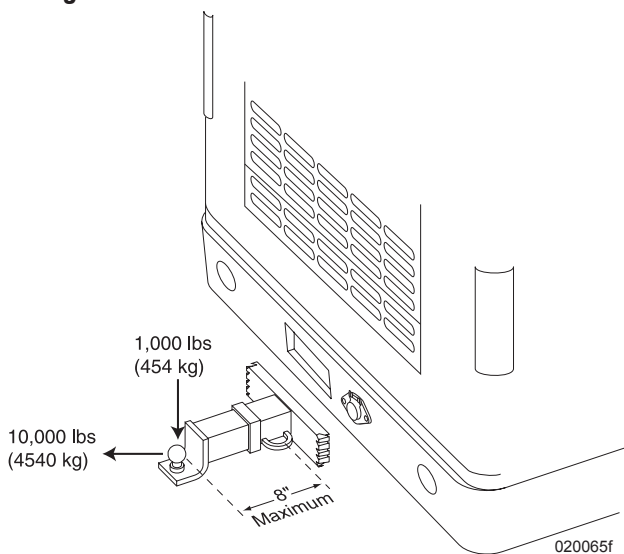

When using the rear hitch receiver, remember that the motorhome is intended for towing light loads and is primarily designed as a recreational vehicle. Safety and durability of the hitch receiver requires proper receiver use. Avoid excessive towing loads or other misuse of the receiver. Towing will affect fuel economy. Weight pushing down on the rear hitch (tongue weight) must not exceed 10% of maximum tow capacity. It is recommended to weigh the motorhome when fully loaded to ensure proper weight distribution of the GCVW (Gross Combined Vehicle Weight).

 MONACO COACH CORPORATION	Do Not Cut, Weld or Modify	03213019
	Do Not Exceed Vehicle Ratings	
	Maximum Towing Capacity 10,000 Lbs. (4,536 Kg.)	
	Maximum Vertical Load 1,000 Lbs. (454 Kg.)	
Coburg, Oregon Springfield, Oregon Wakarusa, Indiana Elkhart, Indiana Nappanee, Indiana	Any Towed Vehicle or Trailer Over 1000 lbs (454 kg) Should Have Separate Functioning Brake System.	
	Refer To Owner's Manual For Additional Towing Guidelines	

100200

When weighing the motorhome, add all passenger weight to the GCVW total. The motorhome fully loaded, including fresh water, LP-Gas and any vehicle or trailer towed, must not exceed the GCWR (Gross Combined Weight Rating).

WARNING:

Most states and Canadian provinces require trailers and/or towed vehicles to have adequate auxiliary brakes. Failure to comply with these State and Canadian province requirements may result in fines and/or pose a safety hazard, which may result in an accident.

WARNING:

DO NOT tow a trailer or vehicle that exceeds the rated capacity of the hitch receiver. Overloading the hitch receiver can cause unusual handling characteristics and overstress the hitch receiver and chassis. It could also void the warranty. If there are any questions, call customer support.

Ball Mount:

Ball mounts come in various configurations and weight limitations. There are three things to consider when selecting a ball mount: weight rating, pin to ball center length and rise/drop. The weight rating of the ball mount, tongue weight and tow weight must meet or exceed the total load weight. Pin to ball center should

not exceed 8 inches. Ball mounts of longer length will significantly reduce the weight rating of the hitch receiver. Observe weight reduction percentages that may be listed on ball mounts longer than 8 inches. Selecting how much rise or drop a ball mount will need is relative to hitch receiver height and height of the towed load with respect to the type of towing equipment between the motorhome and towed load.

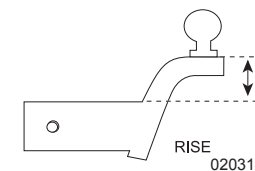

Distance from the top of the shank to the top of the hitch ball platform.

Weight Distributing Hitches:

A weight distributing hitch uses spring bars of spring steel to compensate for lack of adequate rear suspension of the tow vehicle. This type of hitch is generally used for towing heavier loads as tongue weight and gross tow weight increases. The spring bars attach to the hitch head assembly and the trailer frame.

Hitch Ball:

The hitch ball is what the trailer attaches to. A hitch ball is available in three common diameters, 1 7/8", 2" and 2 5/16". The larger the diameter of the hitch ball, the higher the weight rating. The diameter of the hitch ball shank also factors into weight rating. Match shank diameter with the hole in the ball mount or weight distributing head. Shank clearance should not exceed 1/16". There should be at least two additional threads extending past the nut when the hitch ball is secure.

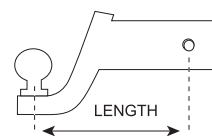

Distance from the center of the hitch ball hole to the center of the pin hole.

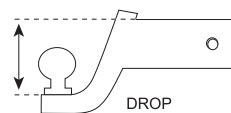

Distance from the shank to the top of the hitch ball platform.

Safety Chains:

Safety chains are required by law when towing any load. The chains and any fasteners used to attach the chains to the hitch receiver must be rated for the load being towed. Attach chains so they crisscross under the towing equipment. Allow just enough slack in the chains to make sharp corners. Too much slack will allow the chains to drag on the road surface. If towed load should become uncoupled from the hitch ball, the towing equipment will be cradled by the safety chains. If the towed load does uncouple, do not attempt to make a sudden stop and exacerbate the situation. Apply the brakes with gentle, steady pressure. Pull over to the side of road at a safe location.

Tow Capacity and Class Ratings:

Several components may comprise a tow hitch system. The weight rating of individual components that are part of the towing system must be greater than the gross weight of the load being towed. To help define weight capacity of towing equipment, components are classified

into weight groups. Maximum tow capacity is limited to the component with the lowest weight rating in the tow hitch system. Example: a ball mount may have a weight rating of 5,000 pounds but the hitch ball is rated 3500 pounds. Maximum tow capacity is reduced to 3500 pounds. Many times a component will have a Class weight rating. These groups are shown in chart:

WARNING:

Be sure the weight ratings of the ball mount, tow ball and safety chains are equal to or greater than the load. The use of an extension to the receiver or extended ball mount will significantly reduce hitch receiver weight ratings. Modifications to the hitch receiver, or use of the hitch receiver other than intended, can void the warranty of the hitch receiver, chassis or both.

Taillight Configuration:

Taillights come in different configurations referred to as a 2-wire or 3-wire configuration. A 2-wire configuration has all red lenses. A 3-wire configuration usually has red and amber lenses. Amber is used for turn signals only and red for taillight and brake light. These systems are electrically different. Whenever hooking a 2-wire system to a 3-wire system, or vice versa, a converter box must be installed for correct taillight function. A taillight converter is available from auto and RV supply stores. **DO NOT** attempt to wire a tow plug connector if unfamiliar with these systems. A trained technician will install the proper converter so the taillights and turn signals work correctly on the motorhome and towed vehicle or trailer when the tow plug connection is made.

	CLASS I	CLASS II	CLASS III	CLASS IV	CLASS V
Weight Carrying Hitch	TW - Up to 200 lbs.	WC TW - Up to 350 lbs.	TW - Up to 500 lbs.	TW - Up to 750 lbs.	TW - Up to 1,200 lbs.
	GTW - Up to 2,000 lbs.	WC GTW - Up to 3,500 lbs.	GTW - Up to 5,000 lbs.	GTW - Up to 7,500 lbs.	GTW - Up to 12,000 lbs.
Weight Distributing Hitch	---	---	---	TW - Up to 1,200 lbs.	TW - Up to 1,400 lbs.
	---	---	---	GTW - Up to 12,000 lbs.	GTW - Up to 14,000 lbs.

- ◆ **GTW** = Gross Trailer Weight. Weight of trailer fully loaded.
- ◆ **TW** = Tongue Weight. Weight pushing down on Tow Ball.
- ◆ **WC** = Weight Carrying. Weight carrying capacity of the Ball Mount.
- ◆ **WD** = Weight Distributing. Weight carrying capacity of a weight distributing hitch.

Tow Plug Connection:

The motorhome is pre-wired from the factory with an electrical connection for towing. The connection is located on the rear cap, near the hitch receiver. Convoluted tubing protects the tow harness wires. Current draw should not exceed 7.5 amps for each designated light circuit. Within the electrical connection is a positive terminal for use when towing a trailer equipped with a battery. The positive terminal maintains the charge of the trailer battery.

When preparing a tow plug connection, strip the wires 3/8". Twist the wire strands and place under the clip and secure the screw. Make sure there are no loose strands of wire that could short against the case or other terminals. **DO NOT** accidentally mirror image the trailer connection.

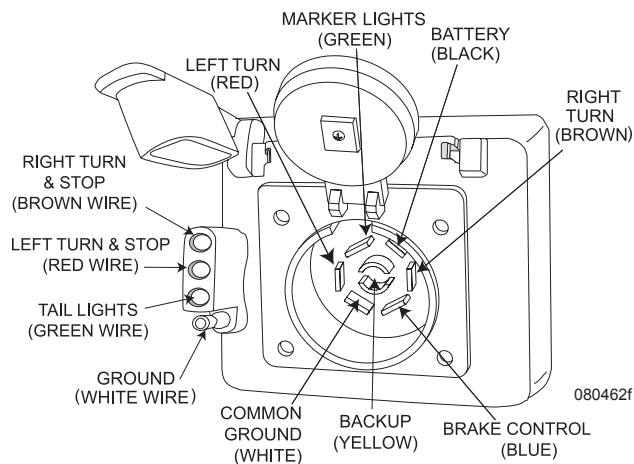

CAUTION:

Positive terminal connection of the tow plug remains live at all times. When towing a trailer equipped with a battery, unplug the electrical tow connection when parked. Failure to unplug the tow connection may result in discharged chassis batteries.

To Tow Car or Trailer:

1. Connect a tow car or trailer to the motorhome with safety chains rated for the weight being towed.
2. Make the electrical connection and perform a light check before starting a trip and at each rest stop.
3. Check the tires frequently. Flat tires on a towed vehicle cannot be detected from the motorhome while driving. A flat tire is a safety hazard and will cause extensive damage.

REAR VIEW SYSTEM

The motorhome is equipped with a rear vision and voice system. This system includes up to four cameras, a microphone mounted at the rear of the motorhome, and a dash mounted stereo with a flip-up screen. The cameras are located at the rear of the motorhome, on both rear view mirrors (optional) and on the bottom of the front overhead cabinet (optional). A camera select feature in the Aladdin™ system is used to alternate camera views.

When the system is on and a turn signal is activated, the monitor will automatically display the appropriate camera view. The camera view will also change to the rear view when the transmission is placed in reverse. The camera views may be accessed from a bedroom LCD. This system may be used while driving in forward, reverse, or when parked.

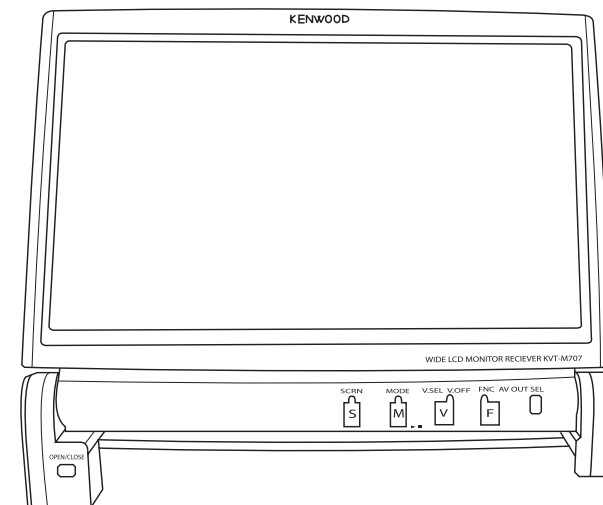

Rear View Monitor

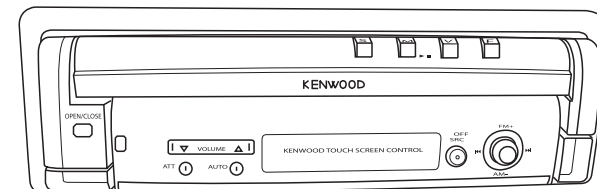

Rear View Monitor in closed position

031251

To Open Monitor:

- ◆ Turn on the battery cut-off switch to engage house power.
- ◆ Press the SRC (Source) button on the monitor deck.
- ◆ Press the Open button to extend monitor screen.
- ◆ Press the SRC button to select mode (mode will display on the bottom of the screen).

To Close Monitor:

- ◆ Press and hold the SRC button until the monitor turns off.
- ◆ Press the Open/Close button to close the monitor.

To Display the Aladdin System:

- ◆ Turn on the battery cut-off switch to engage house power.
- ◆ Turn on and extend the monitor.
- ◆ Move the Aladdin joystick to display the main menu.
- ◆ Use joystick Up/Down to scroll through the main menu. Press joystick right to enter a menu option and left to exit.

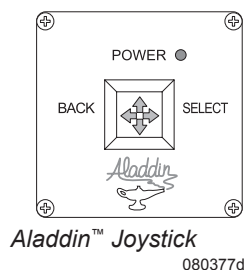
**To Display Camera Views:**

- ◆ Turn on the battery cut-off switch to engage house power.
- ◆ Turn on and extend the monitor.
- ◆ Move the Aladdin joystick to display the main menu.
- ◆ Use joystick Up/Down and move cursor to the “Camera Select” option. Move the joystick to the right to select.

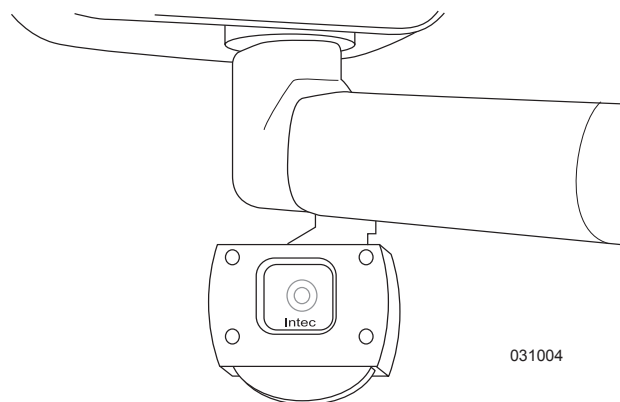
*Side View Mirror Camera (Optional)*

The system will scroll through all camera views. Move the joystick to override the scroll mode and select one view. Leave the system on to enable automatic camera views with turn signal activation or reverse gear selection.

Bedroom Monitor:

A LCD monitor is located in the bedroom. Use the Aladdin joystick mounted near the bedroom monitor to toggle between camera views.

- ◆ Press the **Power** button on the monitor (located on the left side).
- ◆ Access camera views by following instructions to rear view monitor.

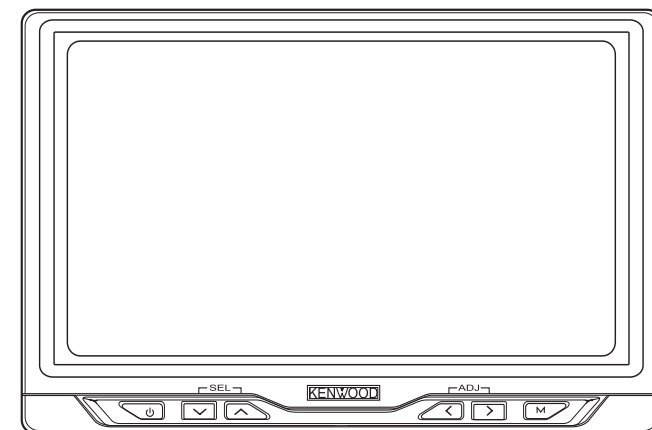
*Bedroom Monitor***BACKING UP A MOTORHOME**

Whether you are a long time owner of recreational vehicles, or just starting out, backing up can be a challenge. Following some simple guidelines may help to reduce that challenge. When backing up, the driver (pilot) should be comfortable using the mirrors, the back-up camera and the co-pilot's directions (ground guide) for assistance. Practice backing up with the co-pilot's guidance in a large, unobstructed parking lot. Backing up is a team effort.

NOTE:

Press the V. Sel/V. Off button if the Aladdin screen does not display.

The backing process should begin while the motorhome is in forward motion. Maneuver the motorhome to align with the chosen site. Aligning the motorhome with the site after the backing process begins may require more than one attempt. When the motorhome is properly aligned with the site, the parking area will be visible in both mirrors. Use road markings as reference points when possible.

When “pull-through” sites are not available, pick a solid, level site on the left side for a better field of vision using the roadside mirror. If the site is on the right, use the curbside mirror for backing up, but stay aware of blind spots. Get out and walk the area prior to backing in. Look for potential hazards or obstacles that may damage the motorhome. If the site is satisfactory, prepare to back in carefully. Have the co-pilot provide guidance using the five hand signals. Use of walkie-talkies will also aid in guidance.

The co-pilot will perform just as important a job as the driver. When guiding the driver, the co-pilot should be located safely at the left rear corner of the motorhome, facing forward, while remaining visible in the roadside mirror at all times. The co-pilot should make a conscious effort to maintain sight of the driver through the roadside mirror as the motorhome maneuvers. If the driver loses sight of the co-pilot, stop the backing up process until the co-pilot returns to view. To avoid mishaps, the co-pilot should be focused only on what the driver is doing, with brief observation moments. If necessary, stop the backing up process to have co-pilot **inspect** other areas or angles of concern.

The driver should receive directions only from the co-pilot. When the co-pilot is guiding the

driver, only five clearly defined signals should be used, with only one signal given at a time. Flailing arms with indecisive signals only confuse the driver. Signals should be given with purpose and confidence. Directional signals are directing travel of the rear of the motorhome.

If the desired direction is left, the co-pilot points left. **For example:** The co-pilot will use his/her right arm and forefinger pointing distinctly left with arm and finger held on a horizontal plane, indicating desired direction of travel of the rear of the motorhome. The directional signal given should remain steady until the desired movement is complete.

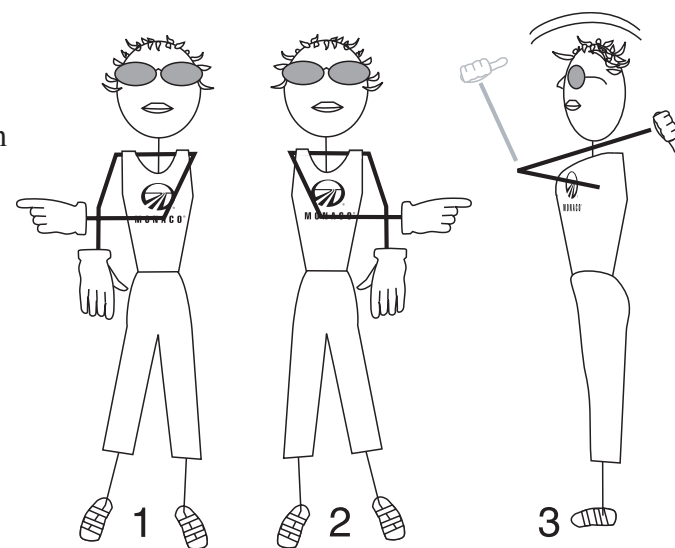

Five Directional Signals:

1. Co-pilot uses left hand and arm held horizontal, with forefinger pointing right, to direct rear of motorhome to the right.
2. Co-pilot uses right hand and arm held horizontal, with forefinger pointing left, to direct rear of motorhome to the left.
3. Co-pilot uses both arms and hands parallel with thumbs pointing up and to rear in a waving vertical motion. This signals driver to maintain a straight back direction.
4. Co-pilot holds arms horizontally, hands open with palms facing one another. Start with a wide separation, gradually closing distance of hands in a rate appropriate to vehicle speed to indicate amount of distance to the stop point.
5. Closed fists and crossed arms indicate **STOP**.

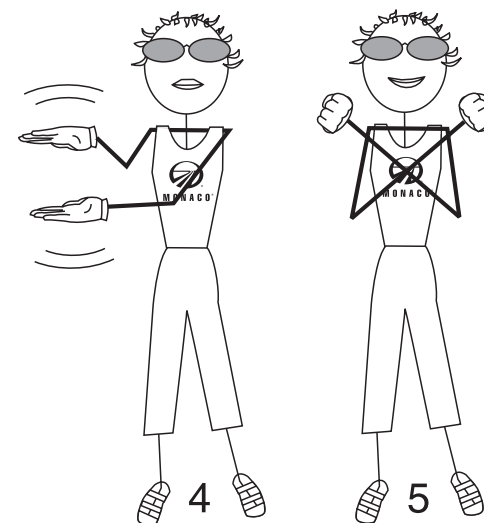

020083b

Backing Up Trailers:

Towed vehicles using a tow bar or tow dolly have more than one pivot point and are not suitable for backing. Attempting to back up the motorhome while connected to a tow bar or tow dolly can jack-knife the tow device causing the wheels of the towed vehicle to move in a forward “sideways” motion that will cause irreparable and expensive damage. If necessary, disconnect the tow vehicle to avoid a backing up situation.

Trailers have one pivot point and may be backed up. The same rules for backing a motorhome can be applied to backing a trailer. When preparing to back the trailer into a space, maneuver the motorhome sweeping wide. Turn back to the opposite direction to maneuver the trailer into the space. Keep the bottom of the steering wheel in the desired direction of travel for the trailer. **For example:** If the desired direction of the trailer is left, rotate the bottom of the steering wheel left.

If the trailer moves in an undesired direction, use a short “pull-up” method, pulling forward just far enough to align the trailer with the space. The co-pilot should stand safely at the left rear corner of the trailer within view of the driver in the roadside mirror, using the five hand signals for guidance.

CAUTION:

Tow bars or car dollies are generally made to travel in a forward direction only. Most towing equipment of this type is not designed for backing. Never attempt short back up distances with a tow bar or tow dolly. Damage to the motorhome, vehicle or towing device will result.

SET-UP PROCEDURES

If the site for the motorhome provides full hook-ups, use this quick reference as a guide only. This information is an overview on hooking up the utilities and preparing appliances for use. Specific information on slide room, awning and leveling system operations is discussed in detail in other sections.

1. Level the motorhome:

- ◆ Follow the procedures and guidelines for “*Leveling the Motorhome*” in Section 10. If the motorhome is equipped with hydraulic jacks, confirm that the parking surface will accommodate the weight placed on the jacks.

2. Hook up utilities and prepare appliances for use:

- ◆ Open the LP-Gas tank primary valve.
- ◆ Prepare the shore cord for connection. Uncoil and **inspect** the cord, and perform necessary cord maintenance. Install proper electrical adapters if anything other than 50 Amp service is provided. Operate electrical appliances in sequence when hooked to limited shore power service. Turn shore power circuit breaker **OFF** prior to plugging in the shore cord.
- ◆ Begin appliance operation on LP-Gas, if hooked to less than 50 Amp service, for the first 60 minutes. Switch the refrigerator operation to gas and start the Aqua-Hot (if needed). This allows time for the inverter to stabilize battery charging.

CAUTION:

If shore power service is limited to 15 or 20 Amps, use of light duty extension cords and electrical adapters will create a voltage loss through the cord and at each electrical connection. Line voltage loss and the resistance at each electrical connection can be a hazardous combination. Damage to sensitive electronic equipment may result.

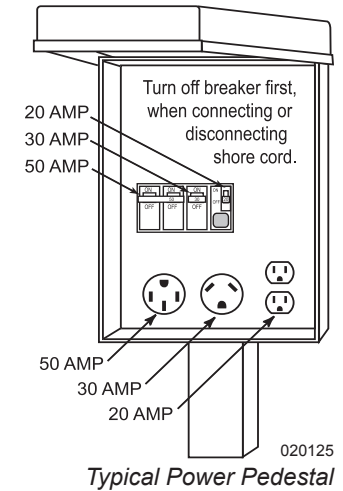

CAUTION:

DO NOT remove cover from the shore power supply to troubleshoot electricity to the motorhome. Serious personal injury or death may occur. If there is no power to the motorhome, inform the park manager. It is the park manager’s responsibility to fix any problems with the shore hook-up at the site.

NOTE:

To avoid shore power overload when hooked to 30 Amp service, determine appliances current load prior to turning on appliances or using interior outlets.

- ◆ If cable service is provided, hook-up a 75 Ohm RG59 or RG6 cable to the cable connection in the service center.
- ◆ A phone connection port is provided in the service center. Phone utility outlets are placed throughout the motorhome, including a phone line attached to the satellite receiver for Pay-Per-View movies and events.
- ◆ Hook the potable water hose to the city water connection in the service center.
- ◆ Hook-up the sewer hose. Sewer drain pipe diameters are generally either three or four inches. Proper sewer hose adapters will ensure against leaks or spillage. With the sewer hose properly connected open the grey water valve (small valve). The black water valve (large valve) remains closed until the tank is full or until time of departure.

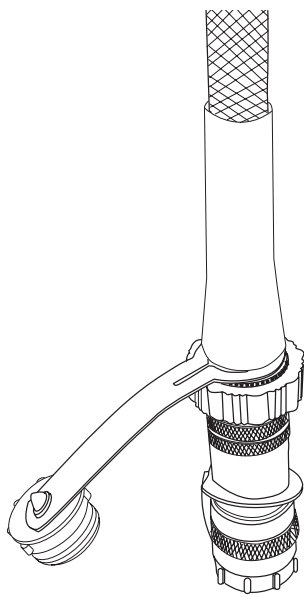

040480m

City Water Connection
with Power Hose Reel

DRY CAMPING

Below are suggestions to follow when staying at a location that does not have electrical, water or sewage hook ups. Plan ahead and conserve resources. Before arriving at the site, ensure batteries are fully charged and properly maintained (see Section 8, Batteries - House, under “*Battery Maintenance*”), the fresh water tank and water heater are full and waste holding tanks are empty.

To conserve water and fuel:

- ◆ Operate the refrigerator on LP-Gas. Plan what is needed from the refrigerator prior to opening, you can conserve LP-Gas by cooking over a campfire.
- ◆ When hot water is needed operate the Aqua-Hot on diesel. Turn the system on about twenty minutes prior to use. Once heated, water will remain hot for several hours. Turn the system off when not in use.
- ◆ Set the thermostat temperature slightly lower than desired to prevent frequent cycling of the heating system.
- ◆ Know the tank capacities and routinely check fuel levels, especially during cold weather.
- ◆ Open windows during the day to reduce use of the roof air conditioner.

- ◆ Frequently monitor water consumption. Limit shower usage; turn water off when soaping down and back on to rinse. When water conservation is critical, take a sponge bath or use campground shower facilities if available. **DO NOT** fill the sink with water to wash only a few dishes. Use disposable dishes when possible.
- ◆ Evacuate waste holding tanks prior to filling fresh water tank.

To conserve battery power:

- ◆ **DO NOT** allow batteries to fully discharge before operating the generator. If possible, run the generator twice a day, morning and afternoon, to charge the batteries.
- ◆ When not using the inverter for 120 Volts AC, turn it **OFF**.
- ◆ Turn **OFF** interior 12 Volt DC power whenever possible. Refrigerator, battery charging and inverter operation will not be affected. Turn **OFF** small battery operated items i.e., porch, bay exterior step, generator and engine compartment lights, etc. Turn **OFF** the antenna boost when not watching TV. One light left on can quickly reduce battery reserves.
- ◆ Keep a working flashlight handy for night trips through the campsite and inside motorhome. When interior lighting is desired, use one light in a central location such as the vanity. Unscrew all but one or two bulbs.
- ◆ If equipped with a solar panel(s), keep panel(s) clean for optimum performance.

- ◆ Turn on the water pump only when using water.
- ◆ If weather does not permit or no outdoor table is available, eat at the dinette table by candlelight.
- ◆ Operate the generator when using microwave/convection oven.

Typical Current Draw	
Battery Cut-off	1.5 Amps
13" TV	1.7 Amps
Rope Light (10 ft.)	1.3 Amps
Porch Light	2.0 Amps
Fluorescent Bulb (1)	2.1 Amps
Halogen Ceiling Light (1)	.09 Amps

BREAKING CAMP

Preparing the motorhome for travel will require several small tasks. Properly securing and storing items will help to prevent them from getting lost or damaged. Below is a checklist guide to reference when preparing to break camp.

Outside Checklist:

- ◆ Disconnect the cable TV and lower the TV antenna.
- ◆ Disconnect and stow the telephone line.
- ◆ Retract awnings and secure them for travel.
- ◆ Close the primary LP-Gas tank valve.
- ◆ Connect the sewer hose.

- ◆ Drain and flush holding tanks. Start by closing the grey water valve. Run enough cold water down sink and shower drains to fill the grey tank at least 50%. Use caution to avoid overfilling or flooding the grey tank. Connect a non-potable water hose to the "Water Inlet Only" fitting in the lower left corner of the service center, open the black tank valve and allow adequate time for black tank to drain. Close black tank valve and open grey water valve. Water from the grey tank will help to flush the drain hose. Once evacuated, close grey water valve. Disconnect the sewer hose and flush that hose with clean water from a non-potable hose. Store the hose. Replace the sewer cap.

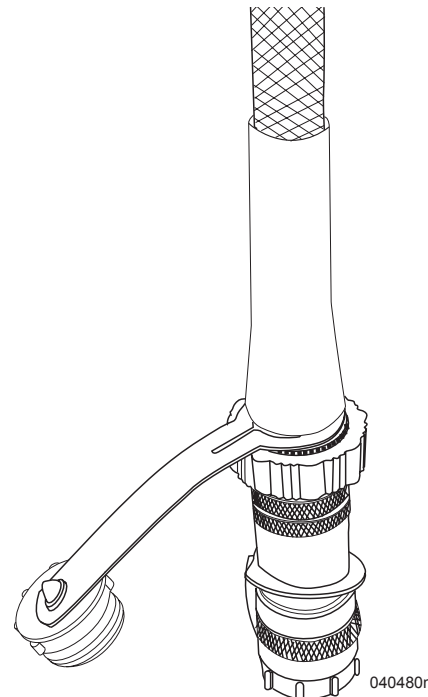

City Water Connection with Power Hose Reel

- ◆ Fill fresh water tank, then disconnect fresh water hose from the source. Store hose with end cap in place. If applicable, remove the hose protection water pressure regulator from the city water faucet.
- ◆ Turn shore power breaker off and disconnect shore line. Wind up and store shore cord. Secure door.
- ◆ **Inspect** fluid level in oil bath hubs (if applicable) and check all tire pressures.
- ◆ Secure all compartment doors.
- ◆ **Inspect** tires and wheels.
- ◆ Check for fluid leaks under and around the motorhome.

Engine Checklist:

- ◆ **Inspect** the engine, transmission and the engine compartment for fluid leaks.
- ◆ **Inspect** the area under the motorhome for fluid leaks or puddles.
- ◆ **Check all fluid levels:** oil, antifreeze, transmission, hydraulic fluid and washer fluid.
- ◆ **Inspect** belts and hoses for wear.
- ◆ **Inspect** wiring for loose, frayed or corroded connections.
- ◆ Start engine and listen for unusual noise.
- ◆ **Inspect** gauges and controls for proper operation.

Interior Checklist:

- ◆ If applicable, retract leveling jacks allowing the air suspension to obtain proper ride height.
- ◆ Clear the slide room path, clean the floor and move the driver seat forward. After confirming bay doors are closed, retract the slide room.

NOTE:

To extend the slide-out room, the ignition must be OFF and the park brake set. The slide-out room can be retracted with the ignition on. However, the jacks must be retracted and the motorhome supported by the air suspension.

- ◆ Secure and fasten the bi-fold and pocket doors. Lock the shower door.
- ◆ Close roof vents and windows.
- ◆ Secure all loose, heavy or sharp objects in case of a sudden stop.
- ◆ Close all cabinet doors and drawers.
- ◆ Turn off interior lights.
- ◆ Turn off the water pump.
- ◆ Check the fuel level gauge and all other dash gauges for operation and correct level indications.

Departure Checklist:

- ◆ Check items in storage bays to ensure shifting or damage of items will not occur.
- ◆ Look around, above and under the motorhome for obstructions. Check for debris stuck between the rear dual tires.
- ◆ Outside compartment doors should be closed and locked.

- ◆ Check operation of all exterior lights, headlamp, taillamp, brake and clearance lights.
- ◆ Secure all awning travel locks.
- ◆ Ensure jack pad is clear of debris when retracting hydraulic jacks. Loose rocks, gravel and debris can be thrown from the jack pad and can possibly damage the tow car.
- ◆ Secure and lock the entry door for travel.
- ◆ Pull forward out of the campsite. Ensure the site is clean and no items are forgotten.

EMERGENCY ROADSIDE PROCEDURES

If an emergency situation occurs use the appropriate braking technique and pull off the roadway a safe distance from traffic (if possible). Set the parking brake and turn on the hazard warning flashers, especially when

parked alongside traffic lanes. In the event of an emergency stop due to a mechanical breakdown or other motorhome related problems, contact the manufacturer's customer support or an emergency service provider.

Road flares or reflective warning signs should be displayed if the motorhome is on the side of the road for any length of time. Guidelines for placing warning triangles depend upon the road characteristics and visibility. **For example:** The standard placement is 10 feet, 100 feet and 200 feet from the rear of the motorhome when on a divided highway or one-way road. On a two-way road, with traffic traveling both directions, the same placement would also be required at the front of the motorhome. Roads with curves and hills may require the placement of the last/furthest triangle to be 500 feet behind the motorhome in order to safely warn approaching traffic.

EMERGENCY SERVICE PROVIDER

Equipment	Provider	Emergency Number
Motorhome: Monaco Coach	Monaco Customer Support	1-877-466-6226
Chassis: Roadmaster	Roadmaster	1-877-466-6226
Engine: Cummins	Cummins Customer Assistance Center	1-800-343-7357
Engine (Optional): Detroit	Detroit Diesel Customer Assistance Center	1-800-445-1980
Transmission	Allison Transmission	1-800-524-2303
Towing	Owner's Advantage Program	1-877-882-0614
Tires: Goodyear	Goodyear	1-877-484-7376

In Case of Flat Tire

In the event of a flat tire, it is recommended to call for roadside assistance.

The size and weight of the motorhome and its tires require proper equipment to change the tire. A professional service technician will have

the equipment and training needed to repair or replace the tire. In the case of sudden tire failure, avoid heavy braking. Hold the steering wheel firmly and gradually decrease speed. Slowly move to a safe off-road place, which should be a firm level spot. Turn the ignition **OFF** and turn the hazard flasher system **ON**. Save the old tire for possible warranty coverage.

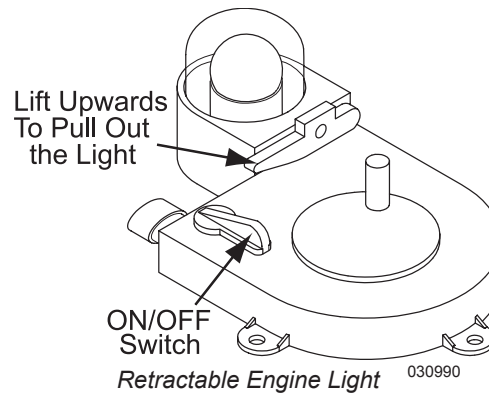

- To rewind, crank the handle in the retract direction. When fully retracted, push down on the lever handle to keep the light locked into place.
- To replace bulb, push down on the clear plastic cover and twist.

Engine Light - Retractable

A retractable light is installed for use in places of limited lighting, such as outside access to the rear engine compartment and roadside electrical compartments.

To Use the Retractable Light:

- Activate the light by turning **ON** the Bay Lights switch on the right side of dash. Turn **ON** the switch on the light.
- The light is on an 18' retractable reel cord. To operate, lift the lever and pull the light out.
- A magnetic base attached to the light enables you to securely position the light for hands free operation.

Battery Boost Switch:

The Battery Boost switch (located on the dash) engages a heavy-duty solenoid to electrically connect the house batteries to the engine battery in the event the engine will not crank or cranks slowly. The solenoid is designed for short-term high current intermittent use. Engaging the boost solenoid for an extended period will damage the solenoid.

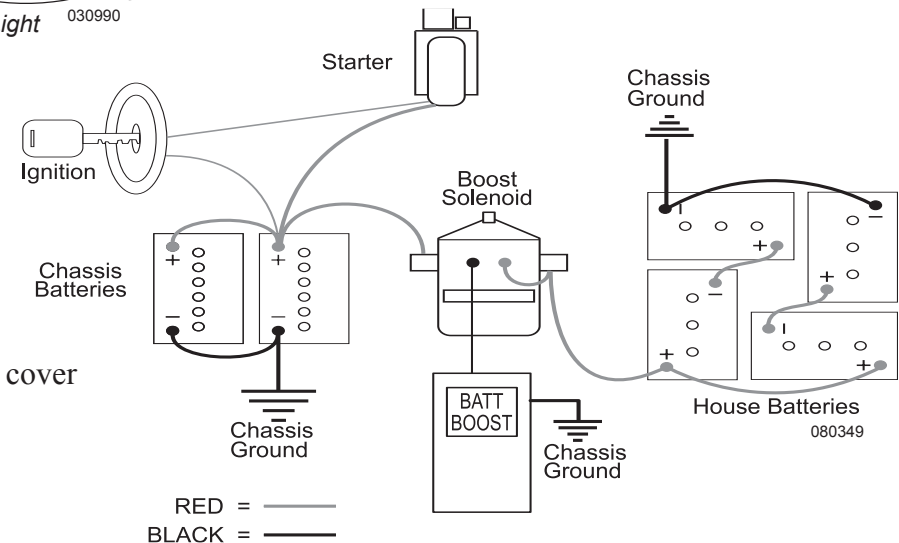

Dead Chassis Battery

A weak or discharged battery will not supply the amount of **CCA (Cold Cranking Amps)** necessary to initiate the required voltage to start the engine. If the engine fails to crank, or cranks slowly due to a weak chassis battery, there are electrical back-up systems in place that may increase chassis battery voltage.

Jump Starting Using the Battery Boost Switch:

- With the ignition key **OFF**, press and hold the Battery Boost switch for ten seconds. After ten seconds, continue to hold the switch down and turn on the ignition. The battery volt gauge on the dash should read at least 12 Volts. If voltage is sufficient, try to start the engine.

- ◆ If the engine fails to crank or does not crank fast enough, discontinue the attempt. Continued attempts will only diminish any remaining surface charge in the chassis battery and end future alternative attempts.
- ◆ Next, start the generator. This may require using the Battery Boost switch for the generator to start from the engine battery. Once the generator is operating, the electrical combination of the generator and the inverter will charge the batteries.
- ◆ Allow the generator to run approximately ½ hour before attempting to start the engine.
- ◆ After ½ hour of generator operation, leave the generator on and hold down the Battery Boost switch for one minute. Release the switch for one minute, then press the switch again for one minute. Alternate this cycle three to five times.
- ◆ Next, hold the switch down and turn the ignition **ON**. The battery voltage gauge on the dash should indicate at least 12 Volts. If voltage is sufficient with the Boost switch held down, try to start the engine.
- ◆ If the engine fails to crank, or fails to crank quickly, the chassis battery may be depleted and the motorhome will require jump-starting or an external charger hooked to the chassis battery.

Jump Starting Using an External Source:

When using jumper cables to start the engine, the cables must connect in a parallel configuration. That is, positive (+) to positive and negative battery (-) to negative chassis (-). Always connect the positive (+) before connecting the negative (-). To prevent arcing when disconnecting the cables; disconnect the negative (-) before disconnecting the positive (+).

WARNING:

Always ventilate the battery compartment prior to any work or service to the batteries. Gas emitted by the batteries can explode when exposed to smoking material, flames, sparks or other sources of ignition, resulting in injury or vehicle damage. Batteries contain sulfuric acid that can burn skin, eyes and clothing. DO NOT connect the end of the second cable to the negative (-) terminal of the battery to be jumped. Connect only to the chassis, away from the battery.

CAUTION:

A large amount of electrical current is required to jump-start an engine. The sizes of the battery, alternator and jumper cables supplying the “jump” are current limiting factors. Wait a sufficient amount of time for a surface charge to build before attempting to start the engine. Voltage fluctuations that occur during a jump-start procedure can damage sensitive electronic equipment and charging systems. If a jump-start is necessary, it is recommended to call Roadside Assistance. They will have the equipment necessary to jump-start the motorhome.

CAUTION:

DO NOT use the towed vehicle for jump-starting. The charging system of the towed vehicle does not supply the amperage necessary to jump-start the motorhome. Voltage sensitive equipment on the towed vehicle can be damaged and render the towed vehicle disabled.

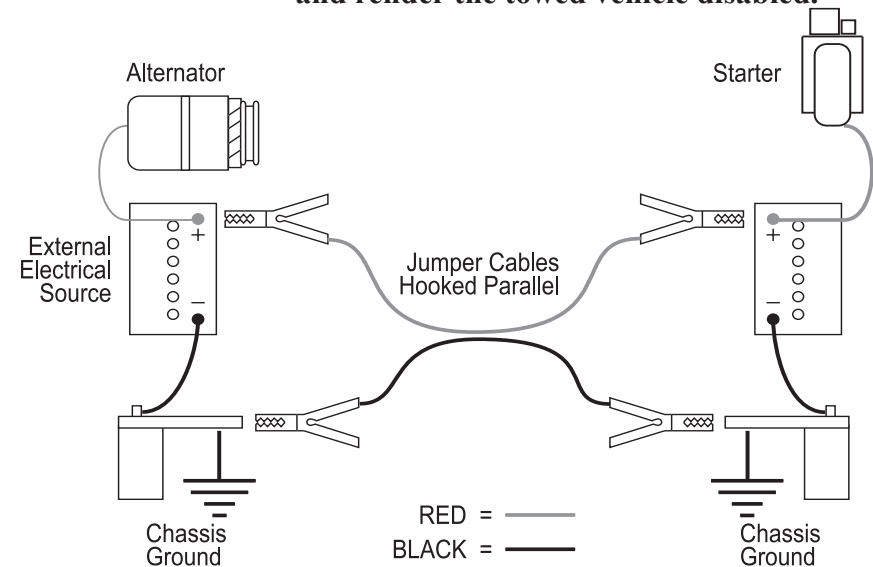

Typical jump-start connection.

080350

1. When using an external electrical source to connect to the chassis battery, turn the main battery disconnect switches **OFF** prior to hooking up the jumper cables.
2. Hook up the cables then wait several minutes to allow a surface charge to build in the chassis battery before attempting to start the engine.
3. Turn **ON** the battery disconnect switches and attempt to start the engine. **DO NOT** crank the engine more than a few seconds.
4. After the engine has started, disconnect the cables. Disconnect the negative (-) cables before disconnecting the positive (+) cables to prevent arcing.
5. If the engine does not crank, or cranks slowly, **DO NOT CONTINUE**. Extensive damage, fire or injury can occur. Obtain help from a qualified technician.

Other important information is the length of the motorhome, number of passengers and milepost location. Two tow trucks may be necessary to tow the motorhome and to tow a trailer or tow vehicle if it is not operational.

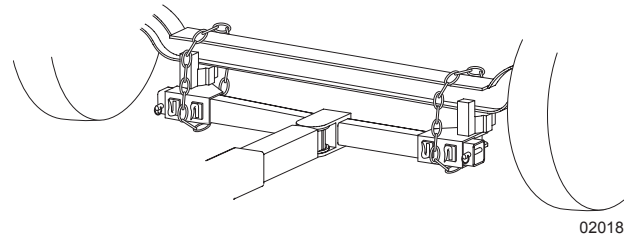
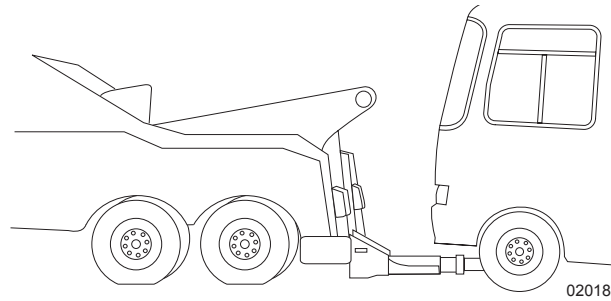

- ◆ Secure any loose or protruding parts if the motorhome is damaged.
- ◆ **Inspect** the points of attachment on a disabled motorhome. If attachment points are damaged, select other attachment points at a substantial frame structural member.
- ◆ Never allow anyone to go under a motorhome while it is being lifted by towing equipment unless the disabled motorhome is adequately supported by safety stands.
- ◆ **DO NOT** tow the motorhome from the rear. Towing from the rear will severely overload the front tires and suspension possibly resulting in tire and/or front suspension failure. Rear frame extensions are not designed to support weight loads imposed by lifting the motorhome from the rear.

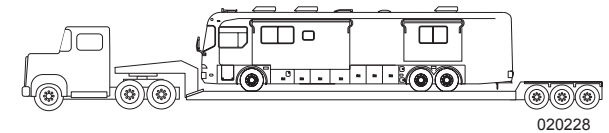

TOWING PROCEDURES

If calling a towing company for service, it is recommended to use a lowboy/landall type of trailer. If a tow truck is used it needs to have a support arm that goes under the motorhome and secures to the front axle. Inform the tow company of the axle weights and total weight of the motorhome.

The towing company may need to locate the air nipple to release the air brakes (air brakes only). The air nipple is located in the generator compartment and should be used by towing personnel only. Generally, if the motorhome ever needs to be towed, use the following instructions:

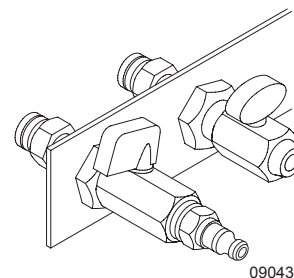

Air Nipple: Located on the Curbside in the Generator Compartment.

- ◆ If the rear wheels are disabled, place the motorhome on a flat bed trailer, or use a heavy duty dolly under the rear wheels and tow the motorhome from the front.
- ◆ The drive shaft must be removed to prevent damage to the transmission. Secure end caps to prevent losing or contaminating the needle bearings.
- ◆ The mud flap may need to be removed to prevent damage due to limited ground clearance.

- ◆ When towing a motorhome equipped with the Air-Leveling System, the ignition **MUST** be left in the **ON** position and the Travel indicator lamp on the panel must be lit for the air suspension to operate. If the ignition system is not functioning, or if chassis voltage is below specification, the motorhome must be placed on a lowboy/landall trailer to prevent suspension damage.

WARNING:

In case the motorhome requires towing, ensure all precautions are followed. The drive shaft must be disconnected and the mud flap may need to be removed. The manufacturer WILL NOT cover damage to the motorhome caused by a towing company.

Disabling Parking Brake

The park/emergency brakes apply to the drive axle only. The brakes can be manually released if the air system will not build sufficient air pressure to release them.

This emergency procedure is to be used by trained technicians or towing personnel to move the motorhome to a safe location or repair facility.

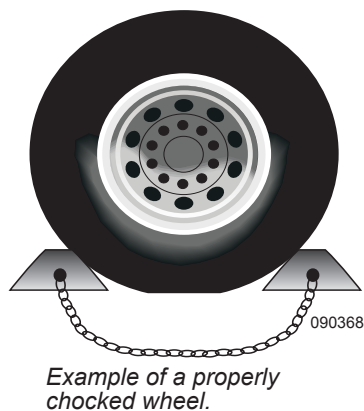

WARNING:

Only trained personnel should perform this procedure. Brake chamber spring is under high pressure. Removal of retaining band could result in serious injury or death.

Disabling Brakes:

- ◆ Place wheel chocks firmly against the wheel before performing this procedure.
- ◆ Remove the plug from the center of rear brake chamber on the drive axle.
- ◆ Remove the caging tool from its holder on the brake chamber and insert the tool into hole. Turn clockwise to engage.
- ◆ Screw nut and washer onto caging tool. Use a wrench to tighten the nut, compressing the internal spring to release the brake.
- ◆ Repeat procedure for the other side.

Enabling Brakes:

- ◆ After towing, or when air pressure is again available, loosen the nut and remove the tool. Return the caging tool to its original location and replace the plug.
- ◆ Repeat for the other side.

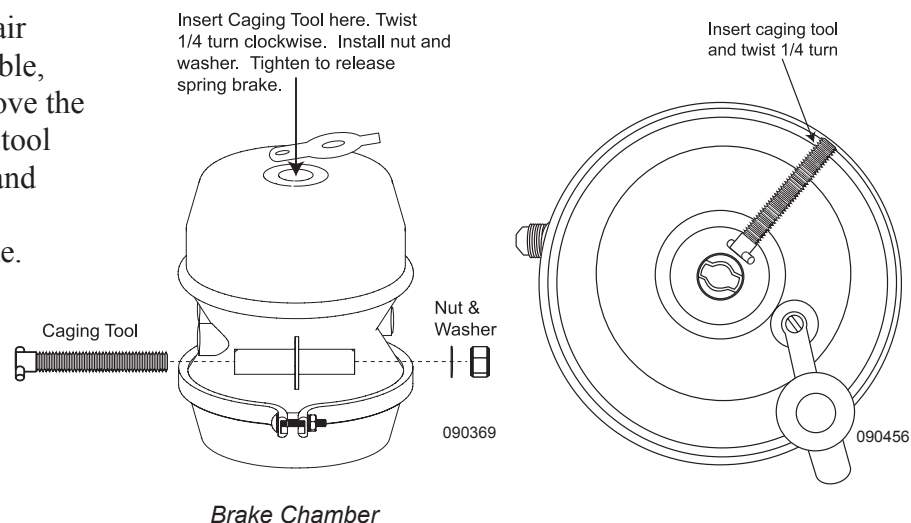

WARNING:

Failure to securely chock the wheels can result in the motorhome rolling when the spring brakes are released. Severe injury or death can occur.

TIRES

Tires designed for the motorhome are a technically engineered product. Since the tire is the only contact the motorhome has with road surface, it is critical that proper air pressure be maintained. Improper pressure will lead to abnormal wear or sudden tire failure. The motorhome must be weighed fully loaded before proper tire inflation pressures can be determined. The following information concerning tires and weighing the motorhome are set in the order in which the process is performed.

The tire performs additional functions of traction for moving, stopping and steering, as well as providing a cushion for the motorhome. Modern tire technology blends a unique mix of chemistry, physics and engineering to provide a high degree of comfort, performance, efficiency, reliability and safety. To obtain the maximum wear and best service from tires, it is helpful to understand their components and functions.

Tire Components:

Tread: Provides traction and cornering grip.

Belts: Stabilize and strengthen the tread.

Sidewall: Protects the side of the tire from road and curb damage.

Body Ply: Gives the tire strength and flexibility.

Bead: Assures an air-tight fit with the wheel.

Inner Liner: Keeps air inside the tire.

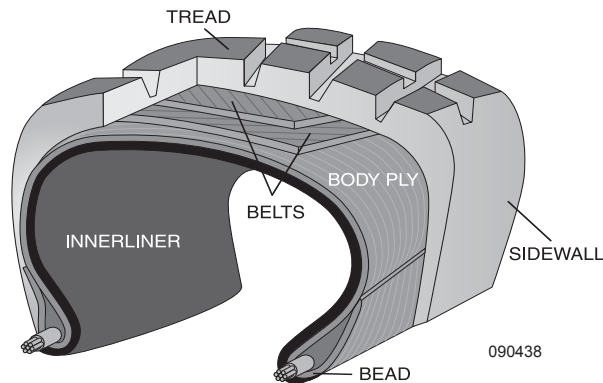

Importance of Air Pressure

The most important factor in maximizing the life of the tires is maintaining proper inflation. Driving on any tire that does not have the correct inflation pressure for the load of the motorhome is dangerous and may cause premature wear, tire damage and/or loss of control of the motorhome.

An under-inflated tire will build up excessive heat that may go beyond the design limits of the rubber and radial cords and could result in sudden failure. An under-inflated tire will also cause poor motorhome handling, rapid and/or irregular tire wear and an increase in rolling resistance that results in decreased fuel economy.

An over-inflated tire will reduce the tire's footprint/contact patch with the road, thus reducing traction, braking capacity and handling of the motorhome. Over-inflation of a tire for the load will result in a harsh ride, uneven tire wear and is susceptible to impact damage. Maintaining correct tire inflation pressure for each loaded wheel position on the motorhome is of the utmost importance and must be a part of regular motorhome maintenance.

WARNING:

Driving on a tire that is under-inflated can exceed the design limits of the tire and may damage the sidewall. A damaged sidewall can burst upon inflation resulting in serious damage, injury or death. Aged tires are also susceptible to sidewall damage.

Tire Pressure Inflation Guideline

Federal law requires that the specifications for the tire's maximum load rating be molded into the sidewall of the tire. The amount of air pressure to use is dependent on the weight of the motorhome when fully loaded. The tire chart indicates the weights that can be properly supported by varying air pressures. Decreasing air pressure decreases load carrying capacity.

Always comply with the tire manufacturer's recommended pressure inflation guideline. The actual weight of the motorhome can vary significantly depending on how it is loaded. For optimum tire wear, ride and handling always comply with the manufacturer guideline. A tire inflation chart listing proper inflation pressure for different loads can be found in this section.

The tires of the motorhome are inflated to pressure(s) appropriate for the actual weight on each axle in the unloaded, shipped condition. When the motorhome is loaded, check and adjust the inflation pressure on each tire as needed.

Always inflate tires to the pressure indicated in the tire chart for the load carried by the tire. **DO NOT OVERINFLATE OR UNDERINFLATE THE TIRES.**

The **Gross Axle Weight Rating (GAWR)** of the axles listed on the federal certification label attached to the motorhome is the maximum allowable loaded weight on an axle.

When the actual loaded weight of the motorhome and the weight on each axle is unknown, follow the recommended tire inflation pressure(s) listed on the federal certification label. When loading a motorhome never exceed the motorhome's **Gross Vehicle Weight Rating (GVWR)** or the **GAWR** for each axle.

Contact the tire manufacturer for further information concerning proper tire pressure inflation and other tire issues.

Tire Chart - Goodyear

Understanding the Inflation Table:

The tire size is on the left margin of the table. Determine the Single inflation reading or Dual inflation reading, denoted with a D or S on the Table. Single is for the front axle and tag axle (if equipped). Dual is for the drive axle. On the following chart, find the corresponding psi at the top columns to see the corresponding maximum weight capacity for that psi.

Rated load capacities are listed for individual tires in a Dual or Single position.

NOTE:

Every load range has a maximum rating as well as a minimum rating. **DO NOT** exceed those ratings.

WARNING:

DO NOT exceed tire manufacturer's maximum speed rating.

Tire Size	Max Speed Rating (MPH)	Single (S) Dual (D)	INFLATION PRESSURE PSI												
			65	70	75	80	85	90	95	100	105	110	115	120	125
8R19.5	75	S	2410	2540	2680	2835	2955	3075	3195	3305	3415	3525(F)			
		D	2350	2460	2610	2755	2865	2975	3085	3195	3305	3415	3415(F)		
225/70R19.5	75	S		2895	3040	3195	3315	3450	3640(F)	3715	3845	3970(G)			
		D		2720	2860	3000	3115	3245	3415(F)	3490	3615	3750(G)			
245/70R19.5	75	S		3640	3740	3890	4080(F)	4190	4335	4540(G)					
		D		3415	3515	3655	3970(F)	4115	4265	4410(G)					
265/70R19.5	75	S				3970	4180	4355	4540	4685	4850	5070	5170	5355(G)	
		D				3750	3930	4095	4300	4405	4560	4805	4860	5070(G)	
9R22.5	75	S		3370	3560	3730	3890	4080	4235	4390	4540(F)				
		D		3270	3410	3550	3690	3860	4005	4150	4300(F)				
10R22.5	65	S		4080	4280	4480	4675	4850	5025	5205(F)	5360	5515	5675(G)		
		D		3860	4045	4230	4410	4585	4760	4940(F)	5075	5210	5355(G)		
11R22.5	75	S		4530	4770	4990	5220	5510	5730	5950	6175(G)	6320	6465	6610(H)	
		D		4380	4580	4760	4950	5205	5415	5625	5840(G)	5895	5950	6005(H)	
12R22.5	75	S		4940	5200	5450	5690	6005	6205	6405	6610	6870	7130	7390(H)	
		D		4780	4990	5190	5390	5675	5785	5895	6005	6265	6525	6780(H)	
245/75R22.5	75	S		3470	3645	3860	3980	4140	4300	4455	4610	4675(G)			
		D		3260	3425	3640	3740	3890	4080	4190	4335	4410(G)			
255/70R22.5	75	S				4190	4370	4550	4675	4895	5065	5205	5400	5510(H)	
		D				3970	4110	4275	4410	4455	4610	4675	4915	5070(H)	
265/75R22.5	75	S		3875	4070	4255	4440	4620	4800	4975	5150	5205(G)			
		D		3870	4040	4205	4370	4525	4685	4805(G)					
275/70R22.5	75	S					5170	5400	5630	5850	6070	6290	6510	6730	6940(H)
		D					4770	4980	5180	5390	5590	5800	6000	6200	6395(H)
275/80R22.5	75	S						5500	5745	5985	6225	6460	6700	6930	7160(H)
		D						5080	5305	5530	5750	5965	6185	6400	6610(H)
295/75R22.5	75	S			4725	4940	5155	5370	5510	5780	5980	6175(G)	6370	6610(H)	
		D			4690	4885	5070	5260	5440	5675(G)	5800	6005(H)			
295/80R22.5	75	S				5480	5750	6020	6285	6550	6810	7070	7320	7580	7830(H)
		D				4855	5100	5335	5570	5805	6035	6265	6490	6720	6490(H)
315/80R22.5	75	S					6415	6670	6940	7190	7440	7610	7920	8270(J)	
		D					5840	6070	6395	6540	6770	6940	7210	7610(J)	
11R24.5	75	S				5310	5550	5840	6095	6350	6610(G)	6790	6970	7160(H)	
		D				5070	5260	5510	5675	5840	6005(G)	6205	6405	6610(H)	
285/75R24.5	75	S			4770	4990	5210	5420	5675	5835	6040	6175(G)			
		D			4740	4930	5205	5310	5495	5675(G)					

The motorhome manufacturer is not the author of this chart and makes no representation or warranty concerning the accuracy of the information disclosed by the chart. Monaco is not responsible for the accuracy of the information disclosed or for any errors within the Tire Inflation Chart. **WARNING: Do not exceed tire manufacturer's maximum speed rating.**

Inspecting & Pressure

The Load and Inflation Table will help determine correct tire inflation pressure after properly weighing the motorhome. All pressures are rated at a cold psi. Cold psi is defined as early in the morning before the day's ambient temperature, sun's radiant heat or the heat generated while driving have caused the tire pressure to temporarily increase. This means the tire inflation pressure should be checked early and when the motorhome has not been driven more than one mile. Check tire inflation pressure regularly. The check interval should be in the morning, before the "drive" trip and every morning on extended trips. A quality truck tire gauge with an angle airhead is needed to access the dual wheel positions of the drive axle. Ensure the valve cap is replaced on the stem after the inflation pressure is checked. Use valve stem caps with a positive seal to prevent air escaping from the valve stem. If there are extension hoses on the valve stem, make sure they are good quality reinforced stainless steel braid. Attach hoses securely to the outer wheel.

The valve stem cap guarantees the valve core will remain free of dirt and foreign material. Material lodged between the valve core and internal stem can cause slow leaks resulting in tire failure.

Optimum tire performance is achieved at proper inflation pressure for the load carried. **DO NOT** mix tires of different tread patterns, size or construction on the same axle. The difference in traction could cause rear end gear bind and mechanical damage to the drive train.

CAUTION:

Never let air out of a hot tire.

Over-inflation can cause:

- ◆ Hard ride.
- ◆ Tire bruising or carcass damage.
- ◆ Rapid tread wear in the center of the tire.

TREAD WEAR

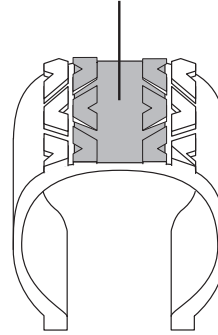

Over-inflation wears in center of tire.

TREAD WEAR

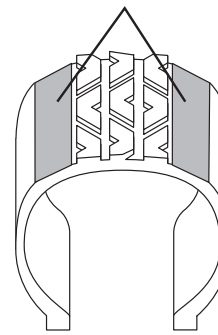

Under-inflation wears on edges of tire.

090440b

Under-inflation can cause:

- ◆ Tire squeal on turns.
- ◆ Separations.
- ◆ Rapid and uneven wear on the edges of the tread.
- ◆ Circumferential breaks.
- ◆ Tire container may bruise or rupture.
- ◆ Higher risk of road hazard.
- ◆ Tire cord breakage.
- ◆ Loss of casing durability.
- ◆ Excessive tire temperature.
- ◆ High fuel consumption.
- ◆ Reduced handling quality.

WARNING:

A slow leak may go unnoticed on one of the dual tires. This can cause the good tire to fail by exceeding the load limit. Tires with damaged sidewalls can burst upon inflation. A flat or nearly flat tire can also generate enough heat from friction to ignite.

Unequal tire pressures on same axle can cause:

- ◆ Uneven braking, swerve upon acceleration.
- ◆ Steering lead, torque steer.
- ◆ Reduced handling quality.

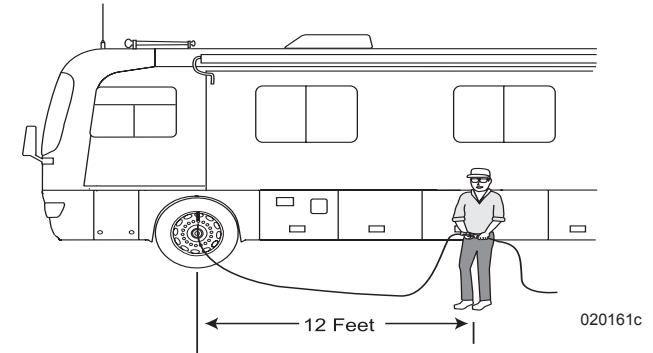

020161c

WARNING:

For safety purposes clear the area of people and pets during tire inflation. Inflate tires using a remote inflation device.

Air Pressure Checklist

1. When inspecting the tires, confirm the tires are cool before increasing or reducing air pressure. Even driving a short distance can heat up tires.

NOTE:

If the motorhome must be driven a distance to get air, check and record the tire pressure first and add the recorded calculation when reaching the pump. It is normal for tires to heat up and the air pressure inside to go up as driven. NEVER “bleed” or reduce air pressure when tires are hot.

2. Remove the cap from the valve on one tire.
3. Firmly press a tire gauge onto the valve and record reading.
4. Add air to achieve recommended air pressure.
5. If the tire is over filled, release air by pushing on the metal stem in the center of the valve. Recheck the pressure with the tire gauge.
6. Replace the valve cap.
7. Repeat with each tire.
8. Visually **inspect** all the tires for nails, or other objects that could be embedded or puncture the tire and cause an air leak.
9. Check the sidewalls for gouges, cuts, bulges, or other irregularities.

NOTE:

Air pressure in a tire goes up (in warm weather) or down (in cold weather) one to two pounds for every 10° F of temperature change.

Supporting When Leveling

Extreme caution must be taken to ensure that the tires are fully supported when placing blocks under the tires. The load on the tire should be evenly distributed on the support block. In the case of dual tires, distribute the load evenly on blocks for both tires. If not properly supported, the steel cables in the sidewall of the tires may be damaged and could lead to premature fatigue of the sidewall.

CAUTION:

Supporting the tires prevents damage to the sidewall of the tires but does not prevent tire roll.

Tire Vibration

Sudden tire failure is often preceded by tire vibration. Symptoms that can cause tire failure are a bulge in the sidewall or swelling in the tire carcass. Striking an object or large hole in the road surface can damage a tire. **Inspect** the tires periodically thereafter as rotational forces can continue to stress damaged areas and later manifest in tire failure. If an unusual vibration begins, or a bulge is noticed in the sidewall, have the tires evaluated by a qualified professional as soon as possible.

Tire "Support" Methods**INCORRECT****Singles**

Only a portion of the tire is supporting the full load.

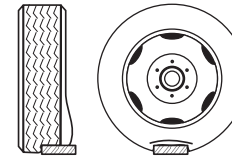
**Duals**

One tire or a portion of one tire is supporting the full load.

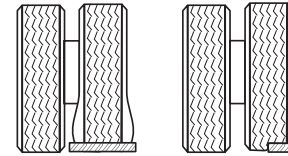

One tire or a portion of the two tires supporting the full load.

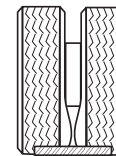
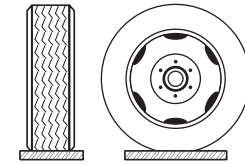
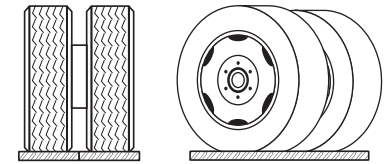
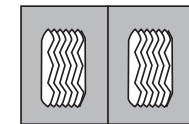
**CORRECT****Singles****Tire Footprints****Duals****Dual Tire Footprints**

020063 mod

Tire Rotation

Tire rotation can increase the useful life of the tires by achieving uniform wear on all of the tires. Have the tire manufacturer determine the rotation pattern. The first tire rotation is the most important in determining which rotation pattern to use. Any unusual or unique wear patterns, or indications of uneven wear that may have developed, should be evaluated for possible tire rotation. Misalignment, imbalance or other mechanical problems may exist and will need to be corrected prior to rotation.

Tread

To prevent skidding and hydroplaning, replace tires when the tread is worn down to 4/32 of an inch on the front, and 2/32 of an inch on the rear. Questions regarding tread wear should be directed to the tire manufacturer.

Built in tread wear indicators, or “wear bars” which look like narrow strips of smooth rubber across the tread, will appear on the tire when the tread is worn down to one-sixteenth of an inch. When “wear bars” are noticed, the tire should be replaced.

Visually check the tires for signs of uneven wear. Signs of irregular tread wear are usually exhibited by low or unusually smooth areas on the tire surface. Consult the tire manufacturer as soon as possible.

WARNING:

In many instances the life of the tires on the motorhome is not determined by mileage but by age. Tires are subject to weathering. Weathering cracks run in circumference with the tire. Though the sidewall of the tire may look structurally sound, weathering can occur inside the well of the tread. Have the tire manufacturer inspect the tires for age weathering.

Storage of Tires - Long Term

A cool, dry garage with a sealed cement floor is the preferred method of storage. Tires stored outside may prematurely age.

Prior to Storage:

- ◆ Thoroughly clean the tires.
- ◆ Unload the motorhome to reduce weight on the tires.
- ◆ Ensure the surface is reasonably level, firm, clean and has good drainage.
- ◆ Inflate the tires to the maximum inflation pressure as indicated on the Federal Identification Tag.

During Storage:

- ◆ Cover the tires to block direct sunlight.
- ◆ Periodically ensure tires are at proper pressure.
- ◆ Move the motorhome every three months to prevent cracking in bulge areas, as well as flat spotting from prolonged sidewall strain and tread deflection.

Removal from Storage:

Before removing the motorhome from long-term storage thoroughly **inspect** each tire’s tread area and air pressure. If the tires have lost air during storage, inflate them to the correct pressure.

WHEEL MOUNTING

Hub Piloted Mounting:

- ◆ Flange nuts generate higher clamping force. Always use grade eight studs with hub mount wheels.
- ◆ Before installing the wheels, lubricate the hub pilot pads with a drop of oil to prevent galling. **DO NOT** lubricate any other wheel or hub surface.
- ◆ For a hub with intermittent pilot pads, position a pad at the twelve o’clock position to center the wheel and reduce runout.

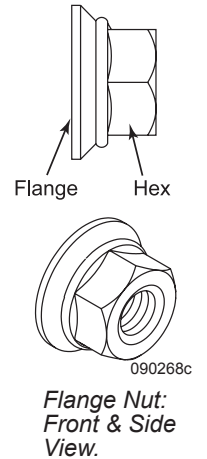

NOTE:

Loosen and tighten lug nuts in sequence (see illustration above). Sequence tighten to 50 ft. lbs. first, then sequence tighten to 500 ft lbs. Over-tightening can cause distortion.

WARNING:

Never use wheels or lug nuts different than the original equipment as this could damage the wheel or the mounting system. Damage to the wheel or mounting system could cause a wheel to come off while the motorhome is in motion.

Front Wheels:

Slide the front wheel over the studs. Use caution to avoid damaging stud threads. Snug the nuts in sequence. When all nuts have been seated, tighten the nuts to 500 ft. lbs. in sequence (as in illustration).

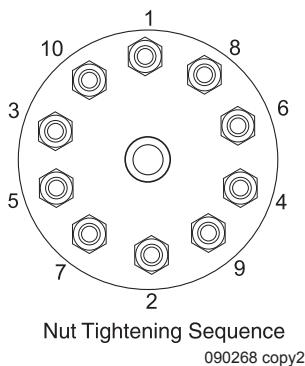
**WEIGHING THE MOTORHOME**

Proper weight distribution, load management and operating within established limitations will aid in safe and enjoyable travel. The information in this section outlines guidelines and provides worksheets for weighing procedures.

Proper weight distribution and load management is an individual responsibility. In order to correctly manage load and weight distribution, more than one weight measurement will be required. Each wheel position must be weighed to accurately determine the weight placed on each wheel position for proper weight computations. The entire process of weight management begins with the **Gross Vehicle Weight Rating** as listed on the Federal Certification Label. **This weight cannot be exceeded.**

CAUTION:

Most States limit the amount of weight carried by any single axle position. It is the responsibility of the operator to know the legal weight limit of the State in which they travel.

Weight Terms

Numerous Federal, State and local governments mandate weight limits. Understanding the terminology and performing proper weighing procedure will help eliminate confusion. It is important to weigh the motorhome to calculate **Cargo Carrying Capacity (CCC)** and ensure no axle is overloaded.

The **Gross Axle Weight Rating (GAWR)** of the axles is listed on the federal certification label attached to the motorhome. This is the maximum allowable loaded weight on a particular axle. This label is generally located to the rear of the driver's seat, on the wall.

When the actual loaded weight of the motorhome, and the weight on each axle is unknown, follow the recommended tire inflation pressure(s) listed on the federal certification label. When loading a motorhome never exceed the **Gross Vehicle Weight Rating (GVWR)** or the **GAWR** for each axle.

NOTE:

Contact the tire manufacturer for further information concerning proper tire pressure inflation and other tire issues.

The **Gross Vehicle Weight Rating (GVWR)** and **Gross Axle Weight Rating (GAWR)** listed on the Federal Certification Label attached to the motorhome details the chassis manufacturer's and/or the RV manufacturer's total vehicle maximum weight rating and per axle weight rating.

The **GVWR** is the maximum total weight for which the motorhome is rated - including passengers, fluids and cargo. The **GAWR** is the maximum weight for which a single axle is designed. The tires, wheels, axle, motorhome frame and/or other components of the motorhome may limit these per axle and total maximum weight ratings.

Torque the Nuts Properly:

- ◆ Tighten the wheel nuts to the recommended lug nut torque. **DO NOT** over tighten.
- ◆ Maintain the nut torque at the recommended level through planned periodic checks or at 10,000 mile intervals, whichever comes first.
- ◆ If air wrenches are used, they must be periodically calibrated for the proper torque output. Use a torque wrench to check air wrench output and adjust line pressure for the correct torque.

The Federal Certification Label is a guide in knowing the maximum loaded axle weight rating **GAWR**, and subsequently the correct tire inflation pressure for that weight. Every recreational vehicle, even of the same make and model, will vary in actual loaded axle weights because of different options and personal loads.

While the actual loaded axle weight should be below the **GAWR**, the motorhome must be weighed in a loaded condition to determine actual weight. Separately weigh the front axle, rear axle and tag axle, if equipped. It is possible for a motorhome to be within the **GVWR** yet overloaded on one axle. It is even possible for one wheel position to be overloaded, even though the **GAWR** has not been exceeded. For this reason it will be necessary to weigh each wheel position of the motorhome to give a clear indication of exactly how the weight of the motorhome is distributed.

Instructions and diagrams are presented on the following pages. When the total weight and the weight on each axle is known, the tire load data chart in this manual will show the correct cold inflation pressure per tire for each axle.

There are two important factors to consider when loading the motorhome: total weight and balance. When loading heavy objects keep them as low as possible, preferably on the floor or below in storage compartments. Load weight must be distributed as evenly as possible.

The following is an explanation of commonly used weight abbreviations:

- ◆ **Gross Vehicle Weight Rating (GVWR):** Maximum permissible weight of this motorhome. **GVWR** is equal to or greater than the sum of **UVW** plus **CCC**.
- ◆ **Unloaded Vehicle Weight (UVW):** Weight of this motorhome as built at factory with full fuel, engine oil and coolants. **UVW** does not include cargo, fresh water, LP-Gas, occupants or dealer installed accessories.
- ◆ **Cargo Carrying Capacity (CCC):** Equal to **GVWR** minus each of the following: **UVW**, full fresh potable water weight (including water heater), full LP-Gas weight, and **SCWR**. Tongue weight of towed vehicle and dealer installed equipment will reduce **CCC**.
- ◆ **Gross Combination Weight Rating (GCWR):** The maximum allowable loaded weight of this motorhome and any towed trailer or towed vehicle.
- ◆ **Gross Axle Weight Rating (GAWR):** Load-carrying capacity specified by manufacturer of a single axle system, as measured at tire ground interfaces.
- ◆ **Sleeping Capacity Weight Rating (SCWR):** The manufacturer's designated number of sleeping positions multiplied by 154 pounds.

Tire Pressure:

A motorhome may weigh slightly heavier on one side. Tire inflation pressure of the heavier side tires determine the inflation pressure for all tire(s) on that axle due to the weight transfer that occurs when cornering.

Improperly inflated tires, or an incorrectly loaded suspension, can result in poor fuel economy, poor handling and over-stressed chassis components. How the motorhome is loaded will influence tire inflation pressure and the load carried by each axle. This is why each wheel position must be weighed. Motorhome axle configuration and floor plan styles will require different weighing procedures.

NOTE:

When weighing a motorhome, each tire on any axle must be inflated to the same pressure. The wheel position carrying the most weight will determine the tire inflation pressure for each tire of that particular axle.

Tag Axle Motorhome (Roadmaster Chassis):

Motorhomes equipped with a tag axle will require adjustment to the air pressure regulator for the tag axle to maintain proper axle weight distribution ratios. The adjustable regulator and gauge package are located in the engine compartment on the roadside. The regulator is designed to control the amount of air pressure in the tag axle air bags. Increasing the regulator pressure gauge reading will increase the amount of air pressure in the tag axle air bags, and downward force of the tag axle. Applying downward force to the tag axle decreases the weight carried by the drive axle.

Tag Axle Regulator Adjustment:

The pressure regulator adjustment knob has a positive lock. Pull up on the knob to unlock; push down on the knob to lock. Turn the knob clockwise to increase air pressure; turn the knob counterclockwise to decrease air pressure. Decreasing regulator air pressure will release excess air through the regulator discharge port. Air pressure stabilization procedures will be performed each time an increase or decrease of air pressure to the regulator is made, equalizing the regulator to hold a constant air pressure setting.

To perform the stabilization procedure:

- ◆ Start the motorhome and allow the air system to reach a full charge, indicated by release of air from the air dryer.
- ◆ Raise the tag axle using the tag axle switch on the shift panel. Allow approximately 20 seconds for the system to discharge air from the tag axle air bags.
- ◆ Lower the tag axle. The regulator will hold the new air pressure setting.
- ◆ Push down on the regulator adjustment knob to lock the setting.

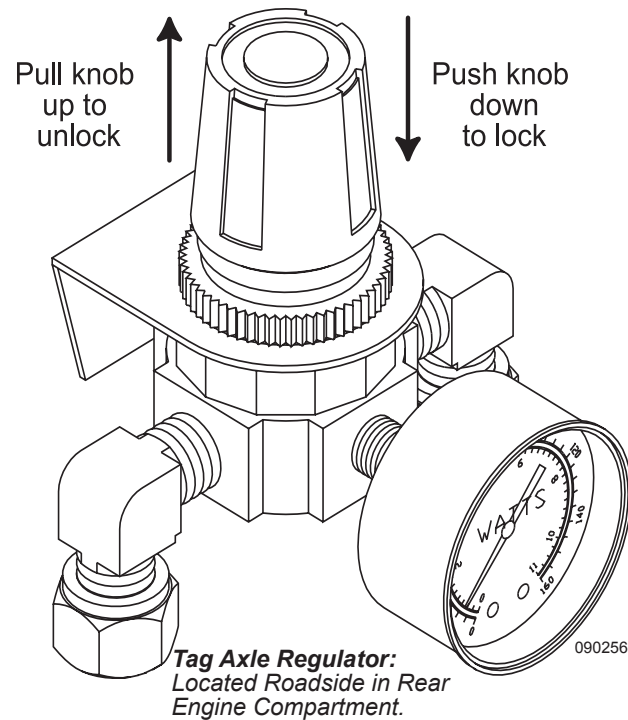

When increasing the air pressure setting allow approximately a two-pound pressure increase before the stabilization process. **Example:** If the desired setting is 30 psi, slowly rotate the regulator adjustment knob clockwise to 28 psi. Perform the stabilization procedure. Regulator setting will stabilize to approximately 30 psi. When decreasing the air pressure setting rotate the regulator adjustment knob counterclockwise, allowing the excess air to be discharged, and then perform the stabilization procedure.

Scales:

Certified public scales are located in moving and storage lots, farm supplies with grain elevators, gravel pits, recycling companies and large commercial truck stops. To locate a nearby public scale access, check the local area

telephone book yellow pages under Scales-Public or Weighers. A nominal fee may be charged, but this is money wisely spent.

Weight scale types and weighing methods determine the procedure used to calculate proper tire inflation pressure and axle loading. Several types of scales are in use today. A platform scale will allow the entire motorhome to fit on the scale to read the **GVW** in one scale recording. A segmented platform scale is designed to weigh one axle at a time. A single axle scale weighs one axle at a time. Some scales read only one wheel position at a time due to physical size. Several scale readings may be required to determine the **GAW** or **GVW** total. Each wheel position requires weighing, referred to as a six-point weigh, to accurately determine the correct tire inflation pressure.

NOTE:

The most accurate method to determine proper tire pressure is six-point weighing. Each wheel position must be weighed independently. Weighing the entire axle will not accurately determine the total weight carried by that wheel position. When calculating the drive axle dual tire pressure using a independent corner weigh method, divide the total weight by two to determine the weight carried by each tire. Each wheel position must be weighed and recorded.

When weighing, the scales and the motorhome must be level to obtain an accurate scale reading. Even when an axle is not physically on the scale, a definite lean in the motorhome will produce inaccurate scale readings.

Weight Label

MODEL YEAR: _____ **MAKE:** _____ **MODEL:** _____

UNIT NO. _____ **CHASSIS VIN:** _____

_____ **LBS.**

_____ **KGS.**

GVWR (Gross Vehicle Weight Rating) is the maximum permissible weight of this fully loaded motorhome

UVW (Unloaded Vehicle Weight) is the weight of this motorhome as manufactured at the factory with full fuel, engine oil and coolants.....

SCWR (Sleeping Capacity Weight Rating) is the manufacturer's designated number of sleeping positions multiplied by 154 pounds (70 kilograms)

CCC (Cargo Carrying Capacity) is the GVWR minus each of the following: UVW, full fresh (potable) water weight (including water heater), full LP-Gas weight and SCWR (*1).....

GCWR (Gross Combination Weight Rating) is the maximum allowable combined weight of this motorhome and the towable product. (*1).....

FACTORY INSTALLED OPTIONS are options installed at the factory but do not include dealer installed after market equipment...

CARGO CARRYING CAPACITY (CCC) COMPUTATION

GVWR

minus UVW

minus fresh water (*2) weight of _____ gallons @ 8.3 lbs./gal

minus LP-Gas weight of _____ gallons @ 4.2 lbs./gal

minus SCWR of _____ persons @ 154 lbs./person

CCC for this motorhome (*3)

WARNING: CONSULT OWNER MANUAL(S) FOR SPECIFIC WEIGHING INSTRUCTIONS AND TOWING GUIDELINES INCLUDING AUXILIARY BRAKE REQUIREMENTS FOR ANY TOWED TRAILER OR TOWED VEHICLE.

Factory installed options do not include dealer installed after market equipment.

WARNING: DO NOT EXCEED THE GVWR, GCWR AND/OR GAWR AFTER LOADING YOUR MOTORHOME WITH WATER, FUEL, PASSENGERS AND CARGO.

GAWR (Gross Axle Weight Rating) means the maximum permissible load weight a specific axle is designed to carry. See Federal Certification Label for disclosure of The GAWR for each axle.

- (*1) Towing capacity is limited by GCWR; your vehicle's towing capacity is the difference between the GCWR and the actual vehicle weight; including all water, fuel, passengers, and cargo. Consult you Owner's Manual for further towing information.
- (*2) Your motorhome's fresh water tank and water heater taken together determine the gross fresh water capacity. Your usable fresh water capacity, however, may be less.
- (*3) Dealer installed equipment and towed vehicle tongue weight will reduce CCC.

Six-Point Weighing Example

The motorhome must be weighed fully loaded to obtain accurate scale readings and to determine the proper tire pressure. All slide rooms must be in the retracted position.

- ◆ Record the Front Axle **Gross Axle Weight Ratings (GAWR)** and divide it by two. **Example:** Front Axle GAWR as listed on the Vehicle Certification Label is 13,000 lbs. Using the chart, record 6,500 lbs. on Scale A and D, line 1.
- ◆ Weigh driver side steer axle (**Scale A**) and record weight on chart Scale A, line 2. **Example:** 5,000 lbs.
- ◆ Weigh passenger side steer axle (**Scale D**) and record weight on chart Scale D, line 2. **Example:** 4,000 lbs.
- ◆ Record the rear axle **Gross Axle Weight Ratings (GAWR)** and divide it by two. **Example:** Rear Axle GAWR as listed on the Vehicle Certification Label is 20,000 lbs. Using chart below, record 10,000 lbs. on Scale B and E, line 1.

- ◆ Weigh driver side drive axle (**Scale B**) and record weight on chart Scale B, line 2. **Example:** 7,100 lbs.
- ◆ Weigh passenger side drive axle (**Scale E**) and record weight on chart Scale E, line 2. **Example:** 6,900 lbs.
- ◆ Take the Tag Axle **Gross Axle Weight Rating (GAWR)** and divide it by two. **Example:** Tag axle GAWR taken from the Vehicle Certification Label is 10,000 lbs. Using the Six-Point Weighing Example Chart (on preceding page), record 5,000 lbs. on Scale C and F, line 1.
- ◆ Weigh driver side tag axle (**Scale C**) and record weight on chart Scale C, line 2. **Example:** 4,500 lbs.
- ◆ Weigh passenger side tag axle (Scale F) and record weight on chart Scale F, line 2. **Example:** 4,000 lbs.
- ◆ Add chart Scale C and F, lines 1, for the **Gross Axle Weight Rating (GAWR)** and record on chart under Totals. **Example:** 10,000 lbs.

- ◆ Add chart Scale C and F, line 2 for actual Gross Axle Weight (**GAW**) and record on chart under Totals. **Example:** 8,500 lbs.
- ◆ Actual Gross Axle Weight (**GAW**). **Example:** 8,500 lbs., is not to exceed **Gross Axle Weight Rating (GAWR)**. **Example:** 10,000 lbs.
- ◆ If necessary, adjust tag axle regulator to compensate for payload carried by tag, drive and front axles.
- ◆ Perform the regulator stabilization procedure.

NOTE:

Adjustments made to the Tag Axle Regulator will require repeated weighing procedures.

- ◆ If necessary, adjust the payload so the GAWR is not exceeded. Total combined weights must not exceed the GVWR.
- ◆ Refer to the Tire Chart in this section (the example tire size is 295/80R22.5). Use the highest actual weight, Scale A or D, line 2. **Example:** 5,000 lbs.; Scale B or E, line 2. **Example:** 7,100 lbs.; Scale C or F, line 2. **Example:** 4,500 lbs. Determine the proper tire pressure for each axle. Front axle tire pressure is 115 psi, Rear axle tire pressure is 85 psi. Tag axle tires are 80 psi using the Load Inflation chart.

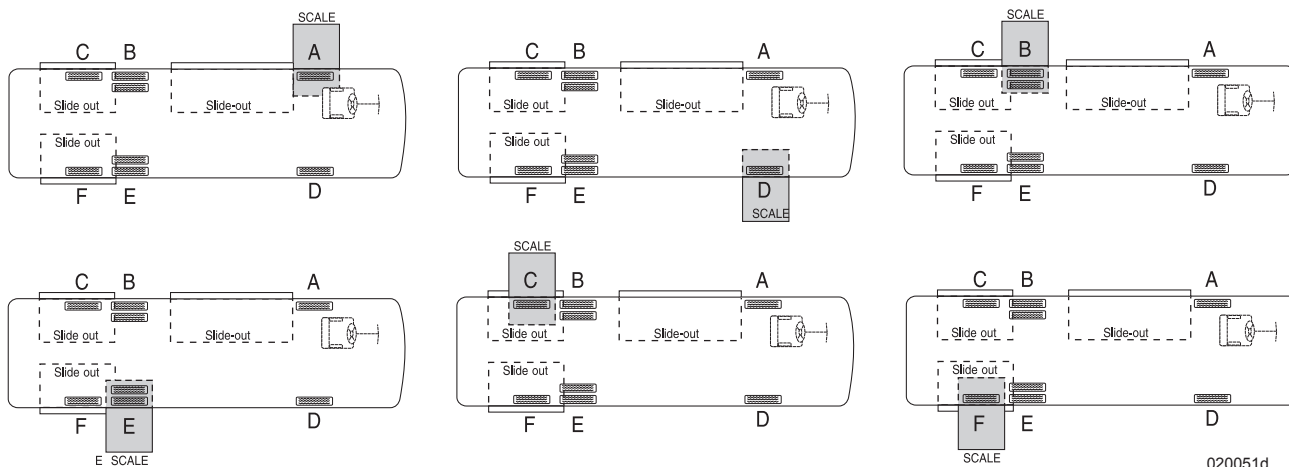

WARNING:

Improperly inflated or overloaded tires can cause a blowout. An overloaded axle can cause a component failure of the suspension system. Tire blowout or broken suspension components can lead to loss of vehicle control resulting in property damage, personal injury or death.

CAUTION:

If actual weight carried by any tire is below the tire chart weight specification minimum tire pressure the minimum inflation pressure must be maintained. Tire pressure below the minimum inflation pressure can overheat and damage the tire casing leading to premature tire failure or blowout.

Cargo Carrying Capacity:

When weighing the motorhome it is important to understand that each motorhome, even of the same model year, floorplan and length will weigh different due to options and accessories. The **Gross Vehicle Weight Rating (GVWR)**, **Gross Combination Weight Rating (GCWR)** and/or **Gross Axle Weight Rating (GAWR)** must not be exceeded.

GVWR limits the weight of the entire load combination, regardless of the water, LP-Gas, passengers and cargo weight.

It is important to understand that the weighing process is performed in two phases. First, by determining the **Cargo Carrying Capacity (CCC)**; and second, to ensure the **GVWR** is not exceeded when adjusting tire pressures. The weighing process should start by recording the **GVWR** from the Federal Weight Label, then weighing the motorhome unloaded, without

	ROADSIDE		CURBSIDE		TOTAL AXLE WEIGHT	GROSS AXLE WEIGHT RATING GAWR	GAWR Minus Total Axle Weight
FRONT AXLE	1. 6,500	+	6,500	=	13,000	13,000	4,000
	2.(A) 5,000		(D) 4,000		9,000		
DRIVE AXLE	1. 10,000	+	10,000	=	20,000	+ 20,000	6,000
	2.(B) 7,100		(E) 6,900		+ 14,000		
TAG AXLE	1. 5,000	+	5,000	=	10,000	+ 10,000	1,500
	2.(C) 4,500		(F) 4,000		+ 8,500		
TAG AXLE REGULATOR	SETTING @ 24 psi		Total Axle Weight		= 31,500 UVW	= 43,000 GVWR	= 11,500 CCC

NOTE:

These measurements are with a full fuel tank and nobody in the motorhome.

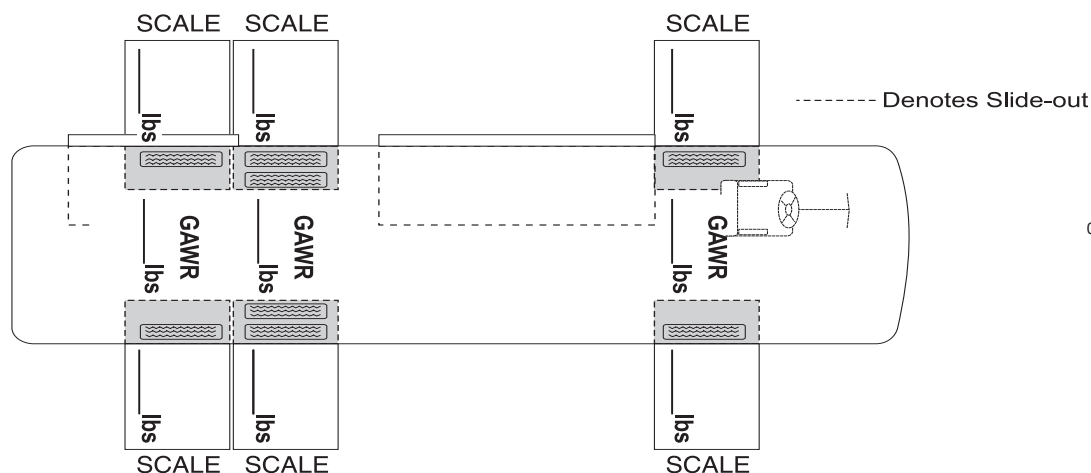

0202550

passengers and with a full fuel tank. Engine and transmission fluid levels must be full. This is known as the **Unloaded Vehicle Weight (UVW)**. Once this weight has been recorded it can be subtracted from the **GVWR**.

GVWR 35,000 - UVW 20,000 = A 15,000

Next, begin to calculate the **Cargo Carrying Capacity (CCC)**. Fresh water weight and LP-Gas weight can now be subtracted from the remaining total line A.

- ◆ Water weight is the number of gallons multiplied by 8.3.
- ◆ LP-Gas weight is the number of gallons multiplied by 4.2.

A 10-gallon water heater with a 40-gallon fresh tank totals 50 gallons times 8.3, or 415 pounds. A 30-gallon LP-Gas tank has 24 gallons of LP-Gas due to the 80% valve. This is 24 gallons multiplied by 4.2, or 100.8 pounds.

A 15,000 - **415** = **B** 14,585

B 14,585 - **100.8** = **C** 14,482.2

Next, calculate the **Sleep Capacity Weight Rating (SCWR)** the manufacturer’s designated number of sleeping positions for the motorhome multiplied by 154 pounds.

The 154 pounds (70kg) is the average weight established by the US Federal Government and Transport Canada, and is used to arrive at **Cargo Carrying Capacity (CCC)**. However, actual sleep capacity weight may be greater. The **SCWR** is not intended to limit the sleeping capacity to a specified weight.

Example: If the manufacturer has designated the motorhome sleeping position at 4 (616 pounds) and there are four people who weigh 200, 200, 178 and 138 pounds, totaling 716 pounds, that doesn’t mean the sleeping capacity is reduced to three individuals, but rather the **CCC** is reduced by 100 pounds due to the actual passenger weight.

C 14,484.2 - **SCWR 716** = **CCC** 13,768.2

Cargo Carrying Capacity (CCC) is how much cargo the motorhome can carry. However, tongue weight of a towed vehicle will further reduce this amount.

Now the motorhome can be fully loaded and weighed to ensure **GVWR** is not exceeded. Once the motorhome is fully loaded it is ready to be weighed to obtain an accurate scale reading and determine the proper tire pressure. All slide rooms must be in the retracted position when weighing the motorhome. The motorhome must remain as level as possible on the scale, even when an axle or side is not physically on the scale.

- ◆ Each wheel position must be weighed to accurately determine the weight carried at each wheel position.
- ◆ Refer to the previous examples on how to weigh each wheel position. Each wheel position weight must be weighed and recorded to determine proper tire inflation.
- ◆ Wheel position weights are not to exceed **Gross Axle Weight Rating (GAWR)** and **Gross Vehicle Weight Rating (GVWR)** as printed on the Motorhome Vehicle Certification Label.
- ◆ Compare wheel position weights with weight ratings on the label. If wheel position weights exceed maximum specifications, items will need to be removed until rating weight is within specification.

Cargo Carrying Capacity Flowchart

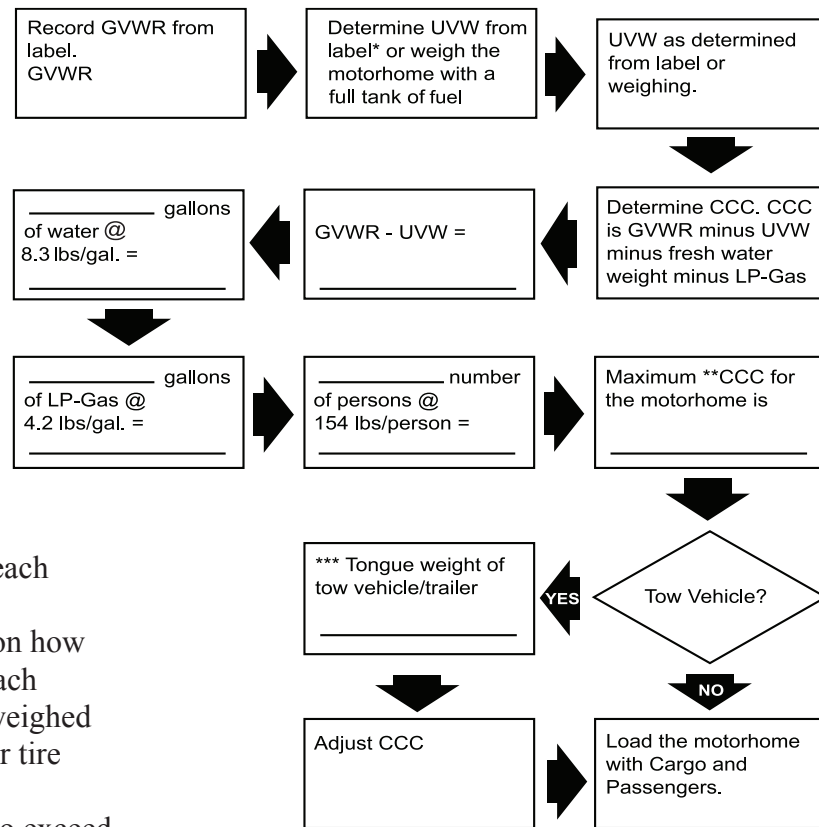

020254d

* Actual UVW may vary based upon options ordered.

** Maximum CCC can be adjusted with amount of water, LP-Gas, number and weight.

*** Actual CCC will vary with number and weight of passengers. Amount of water and LP-Gas and Tow Vehicle/Trailer Tongue weight.

□ = Process

◇ = Decision

Figure Cargo Carrying Capacity (CCC)

Weighing Procedure Worksheet

	ROADSIDE		CURBSIDE		TOTAL AXLE WEIGHT	GROSS AXLE WEIGHT RATING GAWR	GAWR Minus Total Axle Weight
FRONT AXLE	1.	+		=			
	2.(A)		(D)				
DRIVE AXLE	1.	+		=		+	
	2.(B)		(E)		+		
TAG AXLE	1.	+		=		+	
	2.(C)		(F)		+		
TAG AXLE REGULATOR	SETTING @ _____ psi		Total Axle Weight	=	UVW	=	GVWR
						=	CCC

NOTE:

These measurements are with a full fuel tank and nobody in the motorhome.

	FORMULA	UVW CAPACITY	CCC
FRESH WATER	Subtract Gallon @ 8.3 lbs/gal	X 8.3 =	-
WATER HEATER	Subtract Gallon @ 8.3 lbs/gal	X 8.3 =	-
LP-GAS	Subtract Gallon @ 4.2 lbs/gal	X 4.2 =	-
SLEEP CARRYING WEIGHT RATING	Subtract Persons @ 154 lbs/person	X 154 =	-
		Maximum Cargo Carrying Capacity CCC	

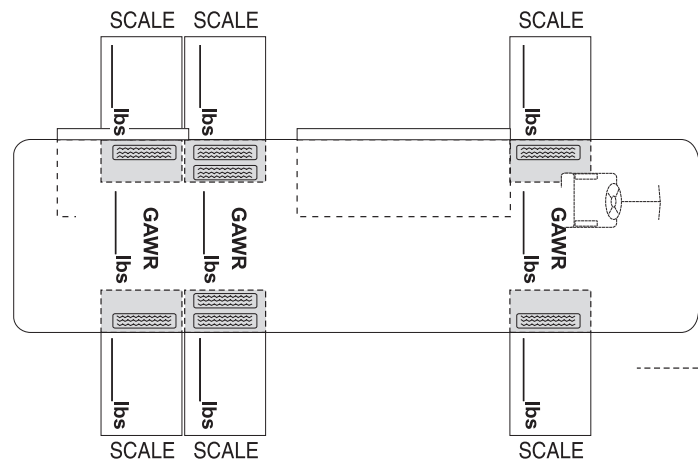

Maximum Cargo Carrying Capacity will change by varying any of the capacities. Tongue Weight of a towed vehicle will reduce the Cargo Carrying Capacity (CCC).

020255c

Weight Record Sheet

DATE: _____

PLACE: _____

FRONT: _____ + _____ = _____

LEFT RIGHT TOTAL

REAR: _____ + _____ = _____

LEFT RIGHT TOTAL

TAG: _____ + _____ = _____

LEFT RIGHT TOTAL

= _____
TOTAL GROSS
VEHICLE WEIGHT

DATE: _____

PLACE: _____

FRONT: _____ + _____ = _____

LEFT RIGHT TOTAL

REAR: _____ + _____ = _____

LEFT RIGHT TOTAL

TAG: _____ + _____ = _____

LEFT RIGHT TOTAL

= _____
TOTAL GROSS
VEHICLE WEIGHT

DATE: _____

PLACE: _____

FRONT: _____ + _____ = _____

LEFT RIGHT TOTAL

REAR: _____ + _____ = _____

LEFT RIGHT TOTAL

TAG: _____ + _____ = _____

LEFT RIGHT TOTAL

= _____
TOTAL GROSS
VEHICLE WEIGHT**VORAD SAFETY SYSTEM (OPTIONAL)**

The following information and instructions will briefly cover features and operations of the VORAD (**Vehicle Onboard RADar**) system. The VORAD system operates in adverse conditions such as darkness, fog, sun glare, snow, rain, dust and smoke. VORAD can track the speed and location of up to 20 vehicles using the most hazardous as the basis for factoring motorhome speed. VORAD provides a series of audible and visual alerts to assist the driver in avoiding collisions. This system is designed as a driving aid and is not a substitute for safe driving practices. The driver is ultimately responsible for safe operation of the motorhome.

INFORMATION:

Refer to the manufacturer's manual for more detail on the VORAD Safety System.

AlwaysAlert:

The antenna assemblies located in the front and sides of the motorhome transmit and receive low power, high-frequency radar signals to continuously monitor the road ahead. The radar can detect moving objects up to 500 ft. and stationary objects up to 220 ft. The Driver Display indicates a yellow light at 3 seconds of distance, an orange light at 2 seconds of distance and a red light at or below 1 second of distance. Audible warnings are issued when immediate action is required to avoid an accident.

SmartCruise:

The VORAD system uses a radar signal to maintain a safe cruise control distance by automatically adjusting engine speed to match following speed with traffic flow. The system engages the engine braking as required to maintain safe distances and automatically returns to cruise set speed when traffic clears.

BlindSpotter:

Side sensors are located near side blind spot areas to reduce lane change/merge collisions. Side sensor warning lights are mounted on the windshield vertical uprights, or "A" pillar, within the same line of sight as the side view mirrors. Yellow indicates the system is functioning while red indicates an object is detected.

Side Sensor Detection:

The side sensors can only detect objects within range, generally as far as the adjoining lane of travel. Stationary objects that maintain a continuous presence, such as guard rails or construction walls, may cause the red sensor display indicator to illuminate.

WARNING:

The VORAD system cannot provide additional warning for situations including, but not limited to, pedestrians or animals darting into the path of the motorhome, head-on collisions involving oncoming vehicles and intersection cross-traffic. This system is not a substitute for safe driving practices.

Side Sensors Display

The side sensor display includes two lights (top and bottom) and a light sensor (middle) located on the windshield A-Pillars.

- ◆ **Yellow (top)** light indicates no obstacle detected by the side sensor.
- ◆ **Red (bottom)** light illuminates when the side sensor detects an obstacle within 12 feet of the motorhome. When the red light is on and the turn signal is activated, a single audible warning is issued when an object is detected.
- ◆ The ambient **light sensor (middle)** measures surrounding light to adjust brightness of the indicators for maximum visibility.

VORAD Driver Display

The driver display contains all the indicators related to the operation of the front “AlwaysAlert” sensor system. The display is mounted in the dashboard. A rocker switch located on the driver side console is used to control system functions. All indicators light up when the ignition is turned ON. The green “SmartCruise” light remains ON following the internal diagnostic check. The “SmartCruise” light will remain ON until the first brake application. The display operates in two modes: **Normal** or **Menu**.

Normal Mode:

Press up or down on the rocker switch to adjust the SmartCruise following

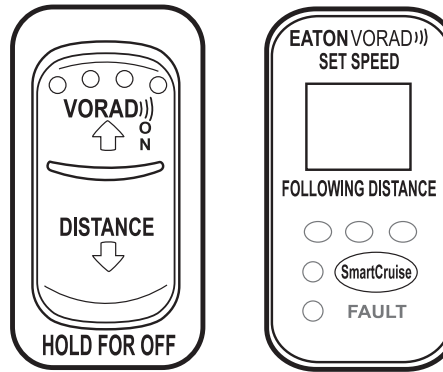

020296

distance from d1 to d8. The d1 setting represents a following distance of approximately 2 seconds behind a lead vehicle and d8 represents a following distance of 3.5 seconds. The driver should adjust the following distance to match traffic conditions and driver preference. The driver can also use the d1 to d8 settings to provide additional time for the “AlwaysAlert” warnings. Earliest warnings are provided at the d8 setting and minimum warnings are provided at the d1 setting; adjust settings to fit driver preference. Select d8 “AlwaysAlert” to enter Fog mode and track vehicles using the yellow light at distances out to 500 feet. The Fog mode can be very helpful when driving in poor visibility situations. SmartCruise is not recommended in poor visibility conditions. Fog mode is not available when SmartCruise is active.

Menu Mode:

Enter Menu mode by holding the rocker switch in the **UP** position until the menu appears (approximately 5 seconds). Press the **DOWN** arrow to scroll through the menu selections listed below.

- ◆ **VL (Volume)** - Adjustments are from V0 (no sound) to V7 (maximum volume).
- ◆ **dE (Demonstration)** - Displays warning lights and tones for each of the collision warnings.
- ◆ **AR (Accident Recorder)** - Data storage last 10 minutes of vehicle operation.
- ◆ **FC (Fault Codes)** - Displays active and inactive fault codes for the service technician.

Press the **UP** arrow to select the desired function. When adjusting the volume, the **up** and **down** arrow is used after selecting the **VL** function. The display will automatically return to the **Normal** mode after 5 seconds of inactivity. The VORAD system can be turned **off** by holding the **down** arrow (5 seconds) until the Driver Display is blank. Press the **up** arrow to turn the VORAD system back **on**.

SmartCruise® - Operation

Smart Cruise® activates when the motorhome cruise control system is engaged and the VORAD System is on. When SmartCruise® is active, the SmartCruise label on the Driver Display will illuminate. The desired following distance can be adjusted using the rocker switch. The system maintains the selected following distance between the motorhome and the vehicle ahead of the motorhome, or in the case of no vehicle ahead, the preset cruise control speed. Following distance takes priority over the preset cruise control speed. The cruise control set speed is indicated on the VORAD driver display.

WARNING:

The VORAD System is not a substitute for an alert, safe driver. SmartCruise® will not react to stationary objects and cannot apply the service brakes to bring the motorhome to a complete stop. The driver is ultimately responsible for the safe operation of the motorhome. The driver should fully understand the operating characteristics and limitations of the SmartCruise® and take all necessary actions to operate the motorhome in a safe manner.

WARNING:

If the motorhome speed and speed of the vehicles ahead significantly differ, apply the service brakes to maintain a safe distance. After a service brake application, the cruise control and SmartCruise® must be RESUMED.

Proximity Alert:

The proximity alert is activated when the motorhome is moving up to two miles per hour and an object is detected less than 10 feet in front of the motorhome. In this case, a light comes ON, accompanied by a low pitch tone.

Special Situations

To use the VORAD System safely and effectively, it helps to understand a number of special road situations and how the system reacts to them. The way the system interprets curves, dips, and hills can sometimes influence the system alerts. Consult the Eaton Driver Instruction manual for a description of these situations.

Data Recorder:

The computer is also capable of storing digital information similar to the black box used on aircraft. In the unlikely event an accident occurs, the data can be retrieved to understand what may have caused the accident. The VORAD computer must be returned to Eaton to retrieve stored data.

SECURITY SYSTEM (OPTIONAL)
Basic Operations

The following information includes instructions for arming and disarming the security system. See the owner's information file box for more information. The following procedures should be performed every six months to ensure that all functions are properly operating.

To Arm the System:

1. Exit the motorhome and close all protected entrances. This includes the entry door, bedroom windows and all bay doors with pin switches.

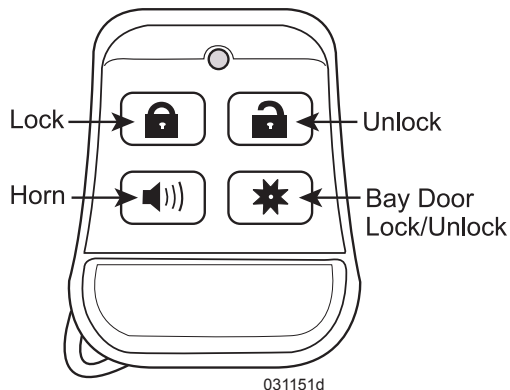

2. Press the “Lock” button on the key fob.

The security system should respond as follows:

- ◆ System will beep one time.
- ◆ Parking lights will flash one time.
- ◆ Dash-mounted LED will flash once every two seconds.

When Armed:

- ◆ A light impact will cause the siren to beep.
- ◆ A continuous or heavy impact will sound the alarm.
- ◆ Opening the entry door, bay doors with pin switches or a bedroom window will cause the siren to beep for three seconds, followed by a continuous alarm.

Disarming:

Press the “Unlock” button on the key fob. The security system should respond as follows:

- ◆ System will beep twice.
- ◆ Parking lights will flash two times.
- ◆ LED will turn off.

Sound and Window Sensors:

Two sound sensors are used to detect impact noise (repetitive or single heavy impact) and glass breakage. Sound sensors are located in the galley and in the bedroom. Window sensors are located on the bedroom windows only. These sensors detect window screen movement. If the screen is opened more than ½", the alarm will sound when the security system is activated.

Each sensor is equipped with a pair of replaceable batteries. Test the sound and window sensors monthly.

To Test Sound Sensor:

- ◆ Clap hands loudly next to sensor. LED should briefly illuminate twice.

To Test Window Sensor:

- ◆ Momentarily press on housing next to LED to briefly illuminate.

Troubleshooting:

- ◆ Red Status LED does not work - Ensure the LED is plugged into the correct socket.
- ◆ System has no power - ensure the 15 Amp fuse (front electrical bay) is not blown.
- ◆ System is not responding to key fob - ensure the Valet switch (see “System Override”) is not on and the key fob battery is not drained.

System Override

The Valet switch (a toggle switch located on the dash) is used to override and/or disable the security system.

Override Operation:

- ◆ Enter the motorhome.
The security system should begin sounding at this point. Ensure the Valet switch is off.
- ◆ Turn the ignition on.

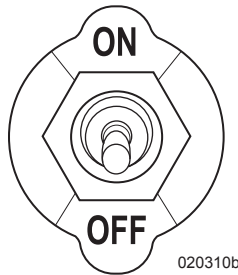

Valet Switch:
Located on
instrument panel.

- ◆ Turn the toggle switch on within five seconds. The security system should stop sounding. The security system is now disabled.

NOTE:

To re-enable the system, turn the toggle switch and ignition off, and press the “Lock” button on the key fob.

Valet Operation (disabling the Security System):

- ◆ Ensure the toggle switch is off.
- ◆ Turn the ignition on.
- ◆ Turn the toggle switch on within five seconds. The system is now disabled.

SAFE (OPTIONAL)

The motorhome uses a small, sturdy floor safe for protection of important documents, semi-precious valuables and petty cash. The safe location will vary with the different floorplans. Consult with the dealership about the safe location.

Contact the safe manufacturer for more information on the safe.

CAUTION:

The safe is designed only for temporary storage of minor personal effects. It is not a suitable replacement for an insured financial institution.

SMOKE DETECTOR

Statistics show that most fire casualties are not caused by direct flame, but by less visible smoke (products of combustion). The smoke detector responds to both visible and invisible products of combustion. The smoke detector will automatically return from alarm to normal state when the reason for activation, the presence of smoke, is completely removed. Fires are commonly caused by smoking in bed, leaving children unattended or using flammable cleaning fluids. Please be safety conscious and avoid unnecessary risk.

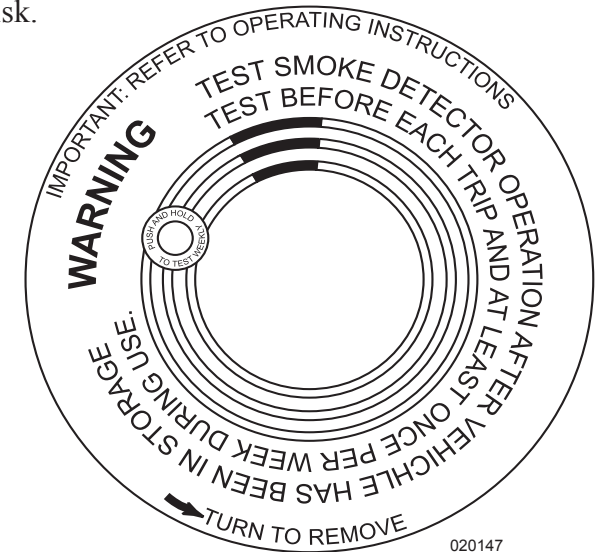
**WARNING:**

There is no way to ensure against injury or loss of life in a fire; however, the smoke detector is intended to help reduce the risk of tragedy. Additional smoke detectors may help to reduce the risk. Proper use and care of the smoke detector could save lives.

Operation

When a 9 Volt DC battery is correctly connected, the LED will flash every minute and a loud alarm will sound when a product of combustion is sensed.

NOTE:

The unit will not operate without a battery. A battery flag will pop up preventing the unit from being installed to the mounting bracket without a battery. Carbon zinc batteries average a service life of one year. Alkaline batteries average a service life of one to two years.

Testing

Simply press the test button on the smoke alarm cover for approximately three seconds. The alarm will sound if all electronic circuitry, horn and battery are properly working. The smoke alarm should be tested at least once a week when the motorhome is in use, prior to each trip and when the motorhome has been in storage. When testing the smoke alarm it is advised to stand at arm's length.

CAUTION:

Never use an open flame to test the smoke alarm as this may ignite the alarm or surrounding area and set fire to the motorhome.

Maintenance

Steps to keep the smoke alarm working properly:

- ◆ Test the smoke alarm once a week.
- ◆ Keep a supply of 9 Volt DC batteries on hand.
- ◆ Vacuum the slots in the cover and sides with a soft brush attachment every month. Test the smoke alarm after the unit has been vacuumed.
- ◆ The smoke alarm will beep once a minute when a low battery condition exists to signify battery must be immediately replaced.

Troubleshooting

If the alarm does not sound when the test button is pushed, or with a smoke test, try the following:

- ◆ **Inspect** alarm for obvious damage.
- ◆ Check for the recommended battery type.
- ◆ Check the battery for proper connection or replace the battery if needed.
- ◆ Gently vacuum as recommended.

If these procedures do not correct the problem, **DO NOT** attempt repairs. If the smoke alarm is within the warranty period and the terms indicate the nature of the problem, return the unit to your dealer. Smoke detectors beyond the warranty period cannot be economically repaired.

CARBON MONOXIDE DETECTOR

American National Standards Institute (ANSI) **A119.2 - Fire & Life Safety 3-4.6 Carbon Monoxide Detectors** states *“All RVs equipped with an internal combustion engine or designed with features to accommodate future installation of an internal combustion engine and truck campers shall be equipped with a listed CO detector installed in accordance with its listing.”*

The motorhome is equipped with a Carbon Monoxide detector. Everyone is at risk with Carbon Monoxide poisoning. Carbon Monoxide (CO) is

a colorless, odorless and tasteless gas that binds with hemoglobin reducing the body's ability to absorb and carry oxygen to vital organs. Even low levels of CO have been known to cause brain and other vital organ damage in unborn infants, with no effect on the mother.

When removed from exposure, the symptoms dissipate as Carbon Monoxide is expelled through the lungs. Level of contamination in the body reduces at half-life increments at approximately four-hour intervals. Treatment with Oxygen will quicken recovery time.

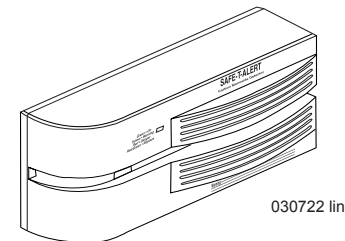

030722 line

In cases of mild exposure, the symptoms may include: a slight headache, nausea, vomiting and fatigue. Some consider this a “Flu-like Symptom.” Symptoms for medium exposure may include a severe throbbing headache, drowsiness, confusion and fast heart rate. Extreme exposure can result in unconsciousness, convulsions, cardio-respiratory failure and death. Young children and household pets may be the first affected. Other highly sensitive people include the elderly and those with lung or heart disease or anemia.

The CO detector is designed to detect the toxic CO Gas resulting from incomplete combustion of any fuel. This can be gasoline, propane, natural gas, oil, charcoal or wood. Anything that burns fuel such as engines, generators, furnaces, gas stoves or water heaters, produce CO Gas. Consequently, it is uncommon for household smoke from cigarettes or normal cooking to cause the alarm to sound.

CAUTION:

Activation of this device indicates the presence of carbon monoxide (CO), which can be fatal. A concentration of above 100 PPM will cause a warning condition. Individuals with medical problems may consider using detection devices with lower carbon monoxide alarming capabilities. Prolonged exposure to the alarm at a close distance may be harmful to hearing.

WARNING:

Constant beeping and a flashing red light means CO gas has been detected. Shut off appliances, motorhome engine, and water heater. Evacuate the motorhome and call the fire department. Have any problems corrected before restarting any appliances or the coach.

The CO detector is wired to both the house and chassis batteries to allow reliable and continuous protection by alerting the build up of potentially dangerous levels of CO. Once the unit is powered, it will run through a brief warm-up and self check prior to monitoring for CO gas. There are no switches that can accidentally turn the system off.

Operation

The detector is equipped with a self-cleaning CO sensor and requires a ten minute initial warm-up period to clean the sensor element and achieve stabilization. During the warm-up period, the green power light will flash **ON** and **OFF**. The green power light should be lit when the power is on. If the light is not lit, turn off the power and check all wire connections. If the power is on and the connections are correct, but the indicator still does not light, the detector should be returned for service. **DO NOT** attempt to fix the detector. The indicator light displays a specific color to monitor along with a matching sound pattern.

Indicator Lights and Sound Patterns:

- ◆ **ON** or normal condition is indicated by **green**. The CO detector has power and is sensing air for the presence of CO Gas. The alarm will not sound.
- ◆ Flashing **red** indicates low CO alarm condition along with **four** beeps then **OFF** for five seconds. The alarm horn will sound and can be reset by the **TEST/RESET** button. The CO detector has detected the presence of 60 ppm.
- ◆ Steady **red** indicates a **CO ALARM** condition. The detector has sensed the presence of levels over 100 ppm of Carbon Monoxide. The alarm horn will continuously sound until the **RESET** switch is reset.
- ◆ Alternating **red** and **green** indicates a malfunction alarm.

Alarm

When the alarm sounds have the detector and the motorhome checked by an authorized service technician as soon as possible. Never disconnect a CO detector to silence an annoying alarm. Evacuate the motorhome immediately when the red light is lit and the alarm sounds. Do a head count to check that all persons are accounted for. Call the nearest fire department and ask them to determine the source of the Carbon Monoxide. **DO NOT** re-enter the motorhome until it has been aired out and the problem corrected.

Potential Sources of CO when operating the motorhome:

- ◆ Engine Exhaust
- ◆ Portable Grills
- ◆ Portable Space Heaters
- ◆ Camp Fires
- ◆ Gas Stoves and Ovens
- ◆ Generator Exhaust
- ◆ Portable Generators
- ◆ Nearby Motorhomes
- ◆ Defective Engine Exhaust System

Testing

Test Procedures:

Test the Carbon Monoxide detector operation after the motorhome has been in storage, before each trip and at least once a week during use. Test the alarm by holding the **TEST/RESET** button in until the alarm sounds. The alarm will sound four beeps and the indicator lamp goes steady **red**. Six seconds later the alarm will again beep four times and the indicator light goes steady **green**.

Peak Level Memory:

The CO detector has the capability to remember the level of Carbon Monoxide that activated the alarm. Press the **TEST/RESET** button for less than one second and observe the visual and audible signals.

- ◆ **One beep** and **one green** flash indicate memory is clear.
- ◆ **Two beeps** and **two red** flashes indicate less than 100 ppm.
- ◆ **Three beeps** and **three red** flashes indicate less than 200 ppm.
- ◆ **Four beeps** and **four red** flashes indicate greater than 200 ppm.

NOTE:

Memory is erased when power is disconnected for 15 seconds.

Cleaning & Maintenance

Use a vacuum cleaner to remove dust or other buildup on the detector. **DO NOT** wash. Wipe the detector with a damp cloth and dry with a towel. **DO NOT** open the detector for cleaning. **DO NOT** paint the detector. It is recommend that the Carbon Monoxide detector be replaced every 10 years.

The CO detector has no user service parts. If there is a problem with the detector refer to an authorized service center. **DO NOT REMOVE POWER.**

INSPECT:

Check the CO detector weekly and at the beginning and end of each trip.

FIRE EXTINGUISHER

The fire extinguisher in the motorhome is located near the main entrance door. Please read the operating instructions that are printed on the fire extinguisher. If there is any doubt on how to operate the fire extinguisher practice using it. Be sure to replace or recharge the extinguisher immediately after use.

Inspect the fire extinguisher at least once a month. Do so more frequently if the extinguisher is exposed to weather or possible tampering. **DO NOT** test the extinguisher by partially discharging. Internal pressure will escape and the fire extinguisher will need to be replaced.

Use the PASS word!

Pull the pin to unlock the extinguisher.

Aim at the base (bottom) of the fire and stand 6 to 10 feet away.

Squeeze the lever to discharge the agent.

Sweep the spray from left to right until totally extinguished.

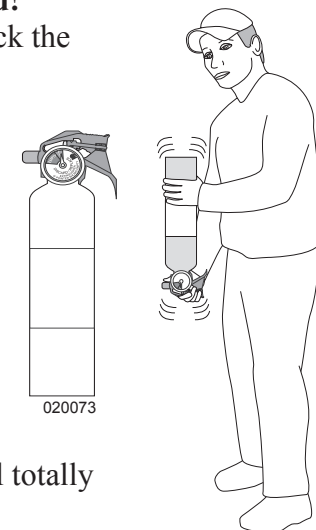

020261

WARNING:

Road vibration will cause extinguisher powder to compact and may cause extinguisher malfunction. Invert and shake extinguisher monthly.

There are three classes of fire to be concerned with in a motorhome. Any fire can fall into more than one class; a fire that involves both burning paper and kitchen grease is a Class AB fire.

Classes of Fire:

A - Fires fueled by materials that leave a residue when they burn: paper, wood, cloth, rubber, and certain plastics.

B - Fires involving flammable liquids and gases: gasoline, paint thinner, kitchen grease, propane and acetylene.

C - Fires involve energized electrical wiring or equipment. If electricity to the equipment is turned off, a class C fire becomes one of the other two class fires.

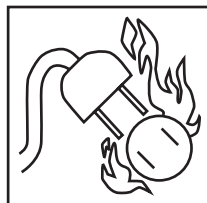

100209

ESCAPE (EGRESS) WINDOW

The Egress window, designated for use as an emergency exit, is identified inside of the motorhome by a red locking handle and Exit label. To open, lift the red handle and push outward. Pull closed and lower handles to lock the Egress window.

Hinges along the outside window top identify the Egress window on the motorhome exterior. The glass slider in the Egress window operates the same as all other windows in the motorhome. Occasionally open and close the Egress window to prevent the rubber seal from sticking.

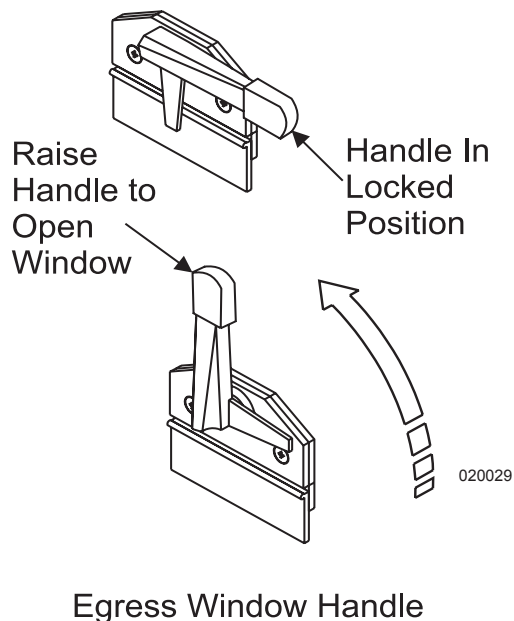

Egress Window Handle

THE EXECUTIVE 07

EXTERIOR & INTERIOR CARE – SECTION 3

EXTERIOR CARE.....	60	FLOORS.....	76
Corrosion.....	60	Carpet Cleaning.....	76
Washing	60	Tile Floor.....	77
Drying.....	60	Laminate Floor (OPT)	78
Waxing	60	SHOWER	78
Paint Codes	61	CEILING.....	78
Tire Care.....	61	WALL COVERINGS	78
Wheels - Coated Aluminum	62	WOOD CARE.....	79
Bright Metal	62	COUNTERTOPS	81
EXTERIOR MAINTENANCE.....	62	Solid Surface	81
Fiberglass	63	STAINLESS STEEL SURFACES	81
Roof Care & Seal Inspections	63	WINDOWS.....	81
Sealant Types.....	63	Condensation.....	81
INTERIOR CARE	65	WINDOW TREATMENTS	82
Cockpit.....	65	Mini-Blinds	82
FABRICS.....	65	Day/Night Shades	82
General Care & Cleaning.....	65	MOLD & MILDEW.....	83
Vinyl	65	PEST CONTROL.....	84
Leather	67	STORAGE	86
Sensuede.....	67	Short Term.....	86
Ultra-Leather	68	Long Term	87
Fabric Cleaning Codes.....	68	Winter Storage Checklist	89
Fabric Specifications Charts	70	Removal from Storage.....	89

EXTERIOR CARE

Corrosion

The most common cause of corrosion to the motorhome exterior is accumulation of road salts, grime and dirt. These elements, combined with moisture, may possibly cause early component failure. The undercarriage, around wheel openings and the radiator charge air cooler package require periodic cleaning to prevent component failure caused from corrosive materials collected on roadways. If the motorhome is driven in areas where road salts are used it should be washed at least once a week. Otherwise, it is recommended to hose off the undercarriage area at least once a month to help minimize the corrosion process. High pressure washers or steam cleaners are the most effective way of cleaning off the underside and inside wheel openings. Avoid directly spraying the painted surface with a high-pressure washer.

CAUTION:

Exercise caution when cleaning the radiator charge air cooler package. Damage to the fins can result when using a high pressure washer or steam cleaner. Nozzle discharge pressure can exceed 1800 psi. Avoid using high pressure steam cleaners on the exterior paint surfaces. Remove all spattered washing debris from the exterior paint surfaces as soon as possible.

Washing

Periodic cleaning will help to preserve the paint finish. The motorhome is painted with a “base coat, clear coat system.” Clear coat is a polyurethane-based material which brings out the shine and luster to the base coat paint. Care should be used when washing the motorhome. Use only mild detergents or (preferred) specifically designed automotive detergents. Avoid abrasive cleansers or laundry detergents that will scratch the clear coat and leave a soap film. Use a soft cloth to wash the paint finish. Avoid brushes as they can scratch the surface and damage the paint. Before washing the motorhome, remove most of the accumulated dirt and “road wash” behind wheel openings, below the windshield and on the rear of the motorhome. If build up is excessive, run water over a soft cotton cloth while gently wiping the surface in one direction. This will help float away the “build-up” from the clear coat. Avoid back and forth or circular motions as this may act like sandpaper, scratching the clear coat and leaving a haze or “swirl marks.” After removing the heavy build-up, use the mixed detergent solution to wash the motorhome. Start washing at the top of the motorhome working towards the bottom. If possible, wash the motorhome in a shaded area when the exterior is not hot to the touch. If necessary, turn the motorhome around to keep the area being washed in the shade. Try not to allow the detergent to dry onto the clear coat surface. Use plenty of water when rinsing the surface to remove all detergent residue.

Drying

Chamois cloths come in natural and synthetic materials. Either type is acceptable as long as the surface is clean. Soak the chamois in clean water, then wring it dry. Remove the water from the surface, starting at the top and working towards the bottom, using a downward “S” pattern. Wring out the chamois as needed. Using a chamois cloth to remove the rinse water is not necessary, but the effort can be worthwhile.

Waxing

To wax or not to wax? This is a good question. There are many schools of thought on this issue. The two most common thoughts are:

- ◆ The clear coat needs to “breathe.” A layer of wax will seal the clear coat and not allow it to breathe, possibly leading to failure of the clear coat.
- ◆ If the surface is not waxed, what is protecting the surface from the environment (road salts, rain, road tar, ultraviolet light)?

It is recommended to wax the motorhome twice a year: spring and fall. Many types of protective barriers are available today that may be applied to the clear coat: glazes, waxes, polishes, rubbing compounds or combinations of these products.

NOTE:

Use a grease and wax remover before applying another coat of wax. Chemicals can become trapped between layers of wax, possibly damaging the paint finish.

INFORMATION:

When selecting a product, follow the product manufacturer's recommended application instructions.

Types of Products:

Glazes - Glazes are generally used to fill very fine scratches in the clear coat. They are applied either by hand or by using a polisher with a special pad.

Waxes - Waxes come in many types of chemical make-up. The popular Carnauba wax is a natural wax from the leaves or fronds of the Carnauba palm tree. Mineral waxes have a paraffin base. There are also waxes which contain silicone.

Polishes - Polishes usually contain a combination of wax based substances with an abrasive, getting the two for one idea. These products can be too abrasive for clear coats and are not recommended for use.

Rubbing Compounds - These types of products are generally applied by using a buffer. The use of rubbing compounds should be left to professionals as undesired results can quickly occur. These types of products are generally used to correct or flatten a surface by removing high spots or small amounts of material.

When selecting a product, the container should be marked, “**safe for clear coats**” or “**clear coat safe.**” Carefully follow the application instructions when using a product. Upon first use of a product, try it on a small test spot in an inconspicuous area in case an undesired reaction occurs.

Observe the test area from different angles to check for hazing or swirl marks. If an abnormal reaction to the finish occurs, discontinue product use and consult the product manufacturer. If the product is a paste, **do not** allow dried paste to be baked on by the sun. Remove paste shortly after drying. Clean, dry, 100% cotton cloths are best suited for the removal of dried paste. Turn the cloth often. Use a separate clean cloth to buff. The surface should feel slick when rubbing the cloth lightly over it. Avoid repeated wax applications which can cause wax to build up. Some very fine scratches or swirl marks may be removed by an application of a glaze. These types of glazes fill the scratches or swirl marks.

The motorhome has a large surface area. Washing and waxing may not be completed in one afternoon. Select sections to wax until the motorhome is complete. If the task seems overwhelming, have an automotive detailer perform the task.

Paint Codes

The motorhome color scheme is comprised of specific paint colors, each assigned a code used to achieve a desired color of paint. “Touch-up” paint may be used to repair a small scratch or imperfection in the paint surface. To paint a larger area, it is necessary to obtain the paint code to get the correct color match.

To Obtain the Paint Code:

1. Contact **National Parts** at **1-877-466-6226**.
2. Specify the year, model, serial number and exterior color scheme name (if known).
3. This formula can be mixed at a local BASF paint store.

NOTE:

All special paint schemes require contacting Monaco Coach directly for paint codes.

Tire Care

Road oil will cause deterioration of the rubber. Dirt build-up can trap chemicals next to the tire and also cause deterioration.

Proper care and methods in cleaning must be used to obtain the maximum service years out of the tires. Use a soft brush and a mild detergent to clean the tires. If a dressing product is used to “protect” the tires from aging, use extra care and caution. Tire dressings that contain petroleum products or alcohol may cause deterioration or cracking.

In many cases it is not the dressing that causes a problem but the chemical reaction that subsequently occurs. When these same dressing products are used on a passenger car tire that is replaced every three to four years, it is rare to see a major problem. However, in most cases recreational vehicle tires may last longer due to limited annual mileage and exposure.

Wheels - Coated Aluminum

Inside:

If the tires are removed, **inspect** and clean the entire rim. Air used to fill the tire may contain moisture and can cause the areas of the wheel under the tire to severely corrode. Use a soft brush to remove any foreign materials from the tire side of the rim. Lubricate the rim and tire bead with a non-water-based lubricant before mounting the tire and ensure the inside of tire is dry before installing.

WARNING:

DO NOT use a flammable solution to coat the inside of the rim. This can lead to an explosion during tire inflation or in subsequent operation of the motorhome.

Outside:

The coated surface of the wheels should be treated the same as the paint finish on the motorhome. Road soils, grime and brake dust trap moisture which can cause corrosion over a period of time.

1. Frequently clean using high-pressure water.
2. Wash with a 100% cotton cloth and a mild soap solution (dish soap or carwash soap is recommended).
3. Rinse all remaining soap residue with high-pressure water and wipe the surface dry using a 100% cotton cloth to avoid water spots.

4. A secondary hand washing may be required to remove some stubborn road films.
5. Carnauba wax can be applied to help protect the finish.

NOTE:

Allow heated wheels that are extremely hot to cool before spraying with cold water.

CAUTION:

DO NOT use the following items on coated aluminum wheels:

- ◆ Polishes (unless marked “safe for clear coat” or Alcoa Aluminum Care).
- ◆ Synthetic cleaning pads, wire or abrasive brushes, steel wool or scouring pads (these can mar or scratch the finish).
- ◆ Strong detergents, alkaline or acidic cleaners, acids or lye-based chemical products or solvents.

CAUTION:

Rinse aluminum wheels using high-pressure water to remove debris from the surface before washing. DO NOT scrub. Rubbing debris against the surface of the wheel can result in scratches. DO NOT allow soap solution to dry on the finish of the wheel as spotting will occur.

INFORMATION:

Instructions for cleaning, handling and minor scratch repair to the coating can be found in Accuride service bulletin 2.0037 Rev 1. Contact Accuride @ 1-800-823-8332 for further information.

Bright Metal

All chrome and stainless steel should be washed and cleaned each time the motorhome is washed. Use only automotive approved non-abrasive cleaners and polishes on exterior bright work. **DO NOT** use rubbing compounds. **DO NOT** use abrasive cleaners or compounds to clean the mirrors.

NOTE:

When using chemicals to remove road tars, use only automotive products that are recommended for painted surfaces and fiberglass. Observe the warning recommendations and directions printed on the container of any agent being used.

EXTERIOR MAINTENANCE

When parked, the motorhome is exposed to extreme temperatures, humidity, ultraviolet rays, rain and other environmental conditions. While in operation the motorhome is subject to twisting and flexing caused by rough roads, potholes and winding mountain roads. Maintenance is necessary not only to keep the exterior looking nice, but also to keep it in proper working order.

Fiberglass

Inspect the fiberglass exterior. Periodic **inspection** may reveal that flexing of the fiberglass exterior has created imperfections in the surface commonly known as “spider” or “hairline” cracks. A crack that has opened up to reveal the cloth weave threatens the integrity of the fiberglass. If the exterior exhibits signs of damage, prevent moisture penetration, particularly in freezing climates. Cover the area using plastic sheeting and/or tape, and have the damaged fiberglass repaired as soon as possible.

Roof Care & Seal Inspections

Wherever there is something affixed to the motorhome, such as the “beltline” or vent attached on the roof, there is a seal preventing water intrusion. There are many types of sealants and each has a specific use. While the beltline uses a silicone or urethane base sealant to prevent water intrusion, roof openings use an acrylic based sealant. Moisture intrusion can occur at any time for a number of reasons. Therefore regular sealant inspection and maintenance will greatly reduce the likelihood of moisture intrusion and costly repairs.

The motorhome is sealed at the factory. However, extreme weather conditions can shorten the life of the sealant while harsh road conditions can compromise sealant integrity. Maintaining sealant integrity is part of regular motorhome maintenance. Inspect all joints, seams and openings at least once every 6 months. While sealant integrity may appear fine, a small void under the right conditions can

quickly cause major damage. Make a full interior inspection for signs of moisture intrusion every two weeks if the motorhome is in storage.

CAUTION:

Inspect exterior seals, seams and joints for sealant integrity at least twice a year. Make a full interior inspection for water leaks every two weeks while the motorhome is in storage.

INSPECTING:

Surface must be clean and dry. Inspect seal for voids, cracks, bubbling, peeling or pulling away. Sealant that looks fine without imperfections is acceptable for continued service. Sealant that is old, cracking, flaking or bubbling will allow moisture intrusion and must be repaired.

WARNING:

Inspecting sealant will require use of a ladder or scaffold assembly. Roof access is also required. Follow proper safety measures accordingly. Exercise extreme care whenever using a ladder/scaffold assembly. Avoid getting on the roof if it is icy or moisture laden as the surface can be very slick. Use judgment if inspection is considered dangerous. Have the motorhome inspected or sealed (if necessary) by a qualified service technician.

Sealant Replacement:

Carefully remove sealant that is cracking, flaking, bubbling, peeling or pulling away from the surface. The area underneath the removed sealant will need to be cleaned and dried before applying new sealant. Applying new sealant over a dirty or moisture laden surface will not

allow proper adhesion. Sealant application may require simple hand tools and paper towels or rags for cleanup. Some sealants may be labeled hazardous or require chemicals for cleanup. Follow all of the manufacturer’s warnings and precautions when dealing with these substances.

WARNING:

Some sealants may be labeled hazardous or require use of petroleum distillates for cleanup. Use proper precautions as suggested by the sealant or chemical manufactures. Use of protective eye wear, gloves, respirator or open ventilation may be required. Use judgment when working with chemicals. If health limits exposure to chemicals or inhibits skills or abilities, employ a qualified service technician to perform the tasks.

Sealant Types

Acryl-R®:

Product Manufacturer Schnee-Moorehead Part # 5504. Used on all roof openings such as vents, skylights, roof-mounted antennas and ladder roof mounts. Sealant should be applied only where equipment bases meet the roof. Acryl-R is generally available in a caulking tube. Two colors are available - white and silver. Silver is used on items mounted on the forward painted area of the roof. White is used at all other points. Remove old sealant that is not adhered. Sealant that is secured need not be removed. Dirty or damp surface areas will compromise sealant effectiveness. Thoroughly clean and dry the surface area before applying new sealant.

Lay masking tape around the area to be sealed to stop sealant from spreading beyond the desired area. Using a caulking gun, apply new sealant as needed. Work the caulking gun in a manner that will cause the sealant to fully adhere to the applied area. Allow adequate cure time. Roof air conditioners use a closed cell foam base gasket and do not require sealant. The roof air conditioners should be regularly inspected for tightness at the four mounting bolts, one located in each interior corner of the air conditioner roof opening. Torque specification is 40 to 50 in/lbs. The base gasket should be compressed to approximately one-half inch.

Acrylic Sealants:

Product Manufacturer Geocel Part # 2300

Used where items are sealed under a painted surface such as the metal corners of slide out rooms and roof mounted awning brackets. The material is specially formulated to allow paint adhesion.

Black Urethane:

Product Manufacturer Bostik Part # 1100

Used for sealing windshields only. Black Urethane is available in a tube that applies similar to silicone. Clean up using solvents such as paint thinner. Gloves are required as this considered a hazardous material.

Silicone:

Product Manufacturer Dow Corning Part # 733

Product made in several colors. Primarily used on the sidewalls around windows, doors, handles, beltline molding, latches and bases of surface mounted items such as clearance lights. Old peeling sealant should be removed with nylon sticks or equivalent. Metal utensils can scratch the painted surface. Avoid lacquer thinners or ketone based solvents as these chemicals can damage painted surfaces. Confirm that surface is clean and dry before a new application. Cut the tube at an angle with the smallest usable opening. Avoid a

heavy bead. A little goes a long way. Wear a disposable latex glove and use finger at a 45° angle on beaded surface to smooth out product. Keep rags or paper towels handy for clean up. Use care when applying silicone and plan ahead before applying. Look for obstacles that may impede application.

Spray Foam:

This product is used as a sealant where a hole has been made for items such as water lines or wires that are coming through a floor or bulkhead opening.

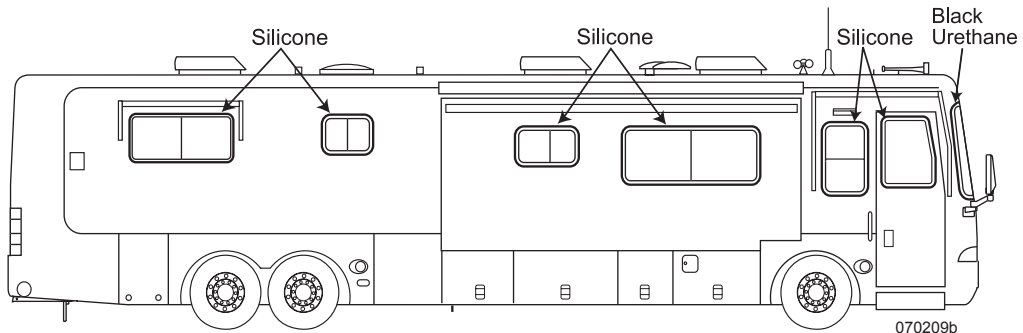

Typical Side View:

Side window seals require silicone. Windshield requires Black Urethane.

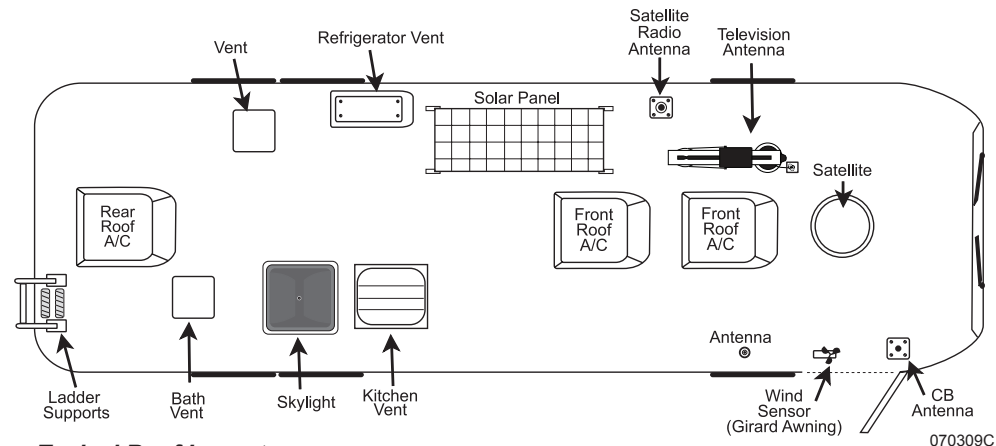

Typical Roof Layout:

Inspect each item for sealant integrity. Acryl-R used as roof sealant. Roof A/C's use a special foam gasket.

INTERIOR CARE

Cockpit

The cockpit area dashboard is a molded-fiberglass, vinyl-wrapped pod. The instrument panel is comprised of various gauges and switches. The dashboard and instrument panel each have different cleaning requirements. Clean the vinyl wrapped dash pod following the instructions under Vinyl Care in this section. In the event a blemish or small cut occurs in the vinyl, contact a professional upholstery repair service.

Clean the plastic or Plexiglas® instrument panels using a cloth dampened in a mild soap and water solution. Dry using a separate cotton cloth. Plastic polish products that will help to brighten the appearance of plastic or Plexiglas instrument panels are Novus Plastic Care®, a three-part system; Meguires® and Johnson Paste Wax®, which will require extensive buffing and rubbing.

Glass lens gauges can be cleaned using glass cleaner. Spray cleaner on the cloth, not directly onto the lens, to prevent over spray or runoff.

CAUTION:

DO NOT allow glass cleaners to come in contact with the plastic. Most glass cleaning products are volatile to plastics, and will cause it to become brittle or dull the finish.

TIP:

To determine if the lens is glass or plastic, tap the lens with a fingernail. Plastic lens will have a dull hollow sound whereas glass will have a clear ping sound.

FABRICS

General Care & Cleaning

Special care needs to be taken when the motorhome is exposed to a very humid climate for an extended period of time. Protect the fabric from any unnecessary exposure to moisture. Cover all upholstery and make sure window coverings are down to protect fabrics from sun damage. Frequently used items require more attention than those items not regularly used.

If a spill occurs, blot the moisture as quickly as possible. **DO NOT** use soap and hot water as this may set a stain. Clean the spot as soon as possible.

Cleaning Upholstery Fabrics:

- ◆ Water-based cleaners are not recommended.
- ◆ If a spill does occur, blot the soiled area. **DO NOT** rub it.
- ◆ Some solvents may have an adverse reaction on a specific backing of the upholstery fabric and are not recommended.
- ◆ To prevent overall soiling, frequently vacuum or lightly brush to remove dust and grime.
- ◆ Clean spots using a mild water-free solvent or dry cleaning product.
- ◆ Clean only in a well ventilated area and avoid any product containing carbon tetrachloride or other toxic materials.
- ◆ Use a professional furniture cleaning service for overall cleaning.

Vinyl

Several areas of the motorhome, such as the dash, ceiling and items of furniture, may be covered in vinyl. The care and cleaning of these areas are as follows:

Normal Cleaning:

Most common stains can be cleaned using warm soapy water and a clear water rinse. Moderate scrubbing with a medium bristle brush will help to loosen soil from the depression of embossed surfaces. For stubborn stains use the following commercially available mild detergents in accordance with the manufacturer's instructions: Mr. Clean or Fantastik®.

Full strength rubbing alcohol or mineral spirits may be tried cautiously as a last resort on very stubborn stains if the above suggestions do not work. Indiscriminate use of any solvent, or solvent containing cleaner, can severely damage or discolor the vinyl. Stains may become permanent if they are not immediately removed.

NOTE:

Detergents should never be used on a regular or repeated basis for normal cleaning.

CAUTION:

Powdered cleaners containing abrasives, steel wool and industrial strength cleaners are not recommended for vinyl.

Bird Excreta & Vomit Stains:

Sponge the area with soapy water containing a diluted bleach until the stain is removed. Rinse thoroughly with clean water.

Urine Stains:

Sponge with soapy water containing a small amount of household ammonia. Rinse thoroughly with clean water.

Surface Mildew:

Wash with diluted bleach and use a soft brush for stubborn growth. Rinse repeatedly with clear, cold water.

Ballpoint Ink:

Wipe the stain immediately with rubbing alcohol in a well ventilated area.

WARNING:

If flammable solvents such as alcohol, turpentine or varsol are used for cleaning, use only small quantities while in a well-ventilated area. Exercise proper caution by notifying any persons in the area. Keep away from any ignition source. Always wear protective gloves.

Oil-Base Paint:

Use turpentine in a well ventilated area to remove any fresh paint. Dried paint must be moistened using a semi-solid, gel-type stripper. The softened paint can be gently scraped away. Rinse with soap and water.

CAUTION:

Lacquer solvent will cause immediate irreparable damage to the vinyl. DO NOT use wax on vinyl upholstery as it will cause premature embrittlement and cracking. Dilute chlorine bleach before using. Never use full strength bleach. Paint strippers will remove the print pattern and damage the vinyl if it comes in direct contact.

Latex Paint:

Fresh paint can be wiped off with a damp cloth. Hot soapy water will normally remove dried latex.

Tar or Asphalt:

Remove immediately. Prolonged contact will result in a permanent stain. Use a cloth lightly dampened with mineral spirits and rub the stain gently, working from the outer edge of the stain toward the center to prevent spreading. Rinse with soap and water.

Crayon, Mustard or Ketchup:

Sponge with mild soap and water. For stubborn stains that have set, use a cloth soaked in diluted mild detergent with gentle rubbing. Any remaining stain should be washed with diluted bleach. Rinse repeatedly with cold water.

Chewing Gum:

Scrape off as much gum as possible using a dull knife. Rub the gum with an ice cube to harden and for easier removal. In a well ventilated area, use a cloth saturated with mineral spirits and gently rub the remaining gum. Rinse thoroughly with clean water.

Lipstick, Grease, Oil, Make-Up or Shoe Polish:

Apply a small amount of mineral spirits with a cloth. Rub gently. Be careful not to spread the stain by smearing beyond the original source. Remove shoe polish immediately as it contains a dye which will cause permanent staining. Rinse thoroughly with clean water.

Candy, Ice Cream, Coffee, Tea, Fruit Stains, Liquor, Wine, Tanning Lotion or Soft Drinks:

Loose material should be gently scraped with a dull knife. Use lukewarm water and sponge repeatedly. Any soiled area that remains after drying should be gently rubbed with a cloth or dampened with a mild detergent solution. Rinse thoroughly with clean water.

Blood or Plant Residue:

Rub out spots using a clean cloth, soaked in cool water. For stubborn spots, use household ammonia and rinse repeatedly with a clean, wet cloth. **DO NOT** use hot water or soap suds as this will set the stain.

TIP:

Vinyl requires periodic cleaning to maintain its appearance and to prevent the buildup of dirt and contaminants that may permanently stain or reduce the life of the vinyl if left untreated. Frequency of cleaning and procedures used depend upon the amount of use and the environmental conditions in which the vinyl is subjected. Tears or holes in the vinyl can be temporarily covered with clear tape to prevent further damage. Repairs should be made by a professional upholstery shop. Commercial repair products may contain lacquers and cause the vinyl to become brittle and more difficult to repair.

Leather**Spots & Spills:**

Absorb excess liquid immediately with a clean cloth or sponge. Use water only if necessary. Do not use a cleaning product. If water is used, clean the entire area where the spot occurred. An example would be the entire seat cushion or the entire arm. Allow to air dry. Do not dry the wet areas with hair dryers, etc.

Stubborn Spots and Stains:

Use lukewarm water and a mild soap to work up a thin layer of suds on a piece of cheesecloth. Scrub the surface. Rinse with a piece of clean, damp cheesecloth. Allow to air dry. Do not use saddle soap, cleaning solvents, furniture polish, oils, varnish, abrasive cleaners, soaps or ammonia water.

NOTE:

These are recommended or suggested methods of cleaning. The manufacturer is not responsible for damage incurred while cleaning. Always test the cleaning method in an inconspicuous area first before applying to the entire area.

Sensuede

Sensuede is an easy care fabric designed to be wrinkle resistant, washable and colorfast. Everyday upkeep is quick once-overs with a suede brush to restore the nap and soft luster appearance of Sensuede.

Laundering/Dry Cleaning:

Sensuede is machine-washable. However, when combined with materials for lining that do not stand up to a washing machine, the fabric should be professionally dry-cleaned.

Stain Removal:

Generally a stain can be removed using a dampened soft cloth. Light stains should be brushed using a suede brush. Deep stains may require rubbing with an eraser or fine sand paper. A knife or spoon may be used to remove sticky stains. Always avoid rubbing the stain into the material.

For Persistent Stains:

Liquid Stains - Coffee, tea, juice, milk, soda, beer, wine, sauce, ink, ketchup, etc: Blot the stain to remove excess residue. Use a cloth soaked in warm sudsy water to remove the stain. A dry cloth should be placed on the reverse side to absorb excess water. Repeat until the stain is removed and no soap residue remains.

Oil Based Stains - Lipstick, cosmetics, shoe polish, ball point pen, markers, butter, salad oil, machine oil, etc. Use the same process as for liquid stains. If the stain remains, a cloth dampened with benzine, alcohol, or a dry cleaning agent can be gently rubbed over the spot.

Paints or Varnish - Use the remover designed for the staining agent. However, as chemicals can harm or discolor the material, test the remover on a corner of the material.

Once stain is removed, blot with a dry cloth to remove any excess water and allow to air dry.

Ultra-Leather

Care Instructions:

- ◆ Spot clean with mild soap and water.
- ◆ Air dry or dry quickly with warm setting of a hair dryer.
- ◆ For stubborn stains, use mild solvent.
- ◆ For tougher stains, try Fantastik® brand spray cleaner.
- ◆ Disinfect with a **5:1 NON-CHLORINATED** (only) bleach solution.
- ◆ Dry clean using commercial dry cleaning solvents only.
- ◆ Use a mild detergent for:
 - Red Wine, Liquor, Coffee, Tea, Cola, Milk
 - Ketchup, Mustard, Mayonnaise, Steak Sauce, Soy Sauce
 - Butter, Salad Oil, Chocolate, Lipstick, Make-up, Face Cream
 - Suntan Oil, Machine Oil, Urine, Blood

Removing ballpoint pen stains:

Wipe the stain off with ethanol (ethyl alcohol). Follow all manufacturer safety instructions when using chemicals.

If the stain remains, use the following procedure:

1. Dilute household bleach (sodium hypochloride) with the same amount of water. (One part to one part solution.)
2. Apply the bleach/water solution to a piece of tissue (do not apply too much). Place the tissue on the stained surface and cover it with polyethylene film to prevent the solution from drying.

3. Periodically remove the tissues to check on the condition of the stain. When the stain is almost gone, remove the tissues completely. Do not leave on for more than one hour.
4. Wash the stain with sufficient amount of clean water.

CAUTION:

If there is residue of bleach, the polyurethane resin and back cloth will deteriorate.

Neutralize bleach by the following method:

- ◆ Place a piece of tissue, as in Step 2, and apply hydrogen peroxide solution (15%).
- ◆ Leave the solution on for approximately 30 minutes, then remove the tissue.
- ◆ Completely remove the residue of hydrogen peroxide on the Ultra-leather with water.

Sodium hypochloride is the only chemical that will remove ballpoint pen stains. However, this chemical may cause polyurethane to yellow or the back cloth to deteriorate. It is recommended to remove ballpoint pen stains as early as possible with ethanol.

**For more information, please call:
Ultrafabrics, LLC
Customer Service: 1-877-309-6648**

Fabric Cleaning Codes

The following fabric cleaning codes list detailed cleaning instructions recommended by the fabric manufacturing industry. Refer to the fabric charts, located on the following pages, for particular fabrics and follow the recommended cleaning code.

“**W**” - Clean this fabric with the foam only of a water-based cleaning agent to remove the overall soil. Many household cleaning solvents are harmful to the color and life of a fabric. Cleaning only by a professional furniture cleaning service is recommended. To prevent overall soil, frequent vacuuming or light brushing to remove dust and grime is recommended.

“**S**” - Clean this fabric with pure solvents (petroleum distillate-based products such as Energine, Carbona, Renuzit, or similar products may be used) in a well ventilated room. Cleaning only by a professional furniture cleaning service is recommended.

CAUTION:

Use of water-based or detergent-based solvent cleaners may cause excessive shrinking. Water stains may become permanent and unable to be removed with solvent cleaning agents. Avoid products containing Carbon Tetrachloride as it is highly toxic. To help prevent overall soiling, frequent vacuuming or light brushing to remove dust and grime is recommended.

“**S/W**” - Clean this fabric with the foam only of a water-based cleaning agent or with a pure solvent in a well ventilated room (petroleum distillate-based products such as Energine, Carbona, Renuzit, or similar products may be used). Cleaning only by a professional furniture cleaning service is recommended. To help prevent overall soiling, frequent vacuuming or light brushing to remove dust and grime is suggested.

“**P**” - The article is resistant against perchlorethene, cleaning benzine (spirit), white spirit, R-11 and R-13.

“**Dry Clean Only**” - Cleaning only by a professional dry cleaner or furniture cleaning service is recommended for this fabric.

“**X**” - Vacuum only. A non-metallic brush may be used.

***Machine Washing for 100%**

Polyester:

“**Wash Cycle**” - Use synthetic setting and high water level with mild agitation. A mild soap or detergent in water not to exceed 160° F. No bleach or fabric softener.

“**Drying**” - Use low temperatures, a synthetic setting of 85° F to 90° F maximum should be used. **DO NOT** exceed three to five minutes time on the synthetic cycle. If washed at 160° F, the maximum temperature which can be used to dry is 140° F. Hang or fold immediately after drying.

“**Finishing**” - If necessary, press as following:

- ◆ Iron on low setting (275° F) with damp cloth or steam iron using a dry press cloth.
- ◆ Grid Head press for short intervals with minimum steam. **DO NOT** lock the head.
- ◆ Flat bed press dampened drapery using cloth covering.
- ◆ Avoid prolonged contact with heat.

Fabric Specifications Charts

CHOCOLATE MINT			
COLOR/PATTERN	APPLICATION	CONTENT	CODE
Tumbleweed Buff	J-Lounge, Euro-Recliner, Steering Wheel, Ensemble	Leather	Leather
Buff	Main Dash (Vacuumed)	Vinyl	Vinyl
Buff	Dash and Vinyl Accents (Wrapped)	Vinyl	Vinyl
Papyrus	Dash Insert	Vinyl	Vinyl
Johnson Cream	Windshield	100% Polyester	Dry Clean
Ultraleather Brisa Distressed Ref#866 Buff	Dr/Pass Chairs	100% Polyurathane Blend w/ 100% Rayon Backing	Ultraleather
Dabble, Chocolate Mint	Sofa, J-Lng, LR/SE Val, Ensemble	55% Rayon Chenille, 45% Polyester	S
Pillowtalk color Gunmetal	LR Pillows	70% Rayon, 30% Polyester	S
Lucid 081057	FSD, LR/SE Valances, BR Chair	67% Rayon, 29% Polyester, 4% Nylon	S
Spirelli-LT color KW39	LR/BR/SE/Priv Lav Valances, LR Pillows	67% Rayon, 29% Polyester, 4% Nylon	S
Kali color Sponge	Bedsread, BR Pillows, BR/Priv Lav Val	100% Silk	Dry Clean
Symi color Eclipse	BR Pillows, Bedsread Accent	100% Polyester	Dry Clean
Ponderosa Bittersweet	Headboard	78% Polyvinyl Chloride , 22% Polyester	W
Feodor color Mahogany	BR Pillows, BR Shams, Bedsread Welt, BR/Priv Lav Valances	43% Polyester, 42% Olefin, 15% Cotton	S
Prado 3848-10363 color 700	BR Pillows, BR Shams	43% Rayon 34% Polyester 23% Cotton	S - Dry Clean
BCD 02968-01-A Copper Brown	Decorative Trim - Boucle Cord	50% Rayon, 43% Polyester, 7% Polypropylene	S
CD 02968-01-C Copper Brown	Decorative Trim - Cord	48% Polyester, 38% Rayon, 14% Polypropylene	S
Sensuede 9065 Latte	Ceiling Accent D	88% Polyester 12% Polyurethane	S - Dry Clean
Sensuede 9047 Sand	Ceiling Accent E	88% Polyester 12% Polyurethane	S - Dry Clean

RUBY RUSH			
COLOR/PATTERN	APPLICATION	CONTENT	CODE
Tumbleweed Papyrus	J-Lounge, Euro-Recliner, Steering Wheel, Ensemble	Leather	Leather
Papyrus	Main Dash (Vacuumed)	Vinyl	Vinyl
Papyrus	Dash and Vinyl Accents (Wrapped)	Vinyl	Vinyl
Sand	Dash Insert	Vinyl	Vinyl
Johnson Cream	Windshield	100% Polyester	Dry Clean
Ultraleather Brisa Dist. Ref #866 Papyrus	Dr/Pass Chairs	100% Polyurathane Blend w/ 100% Rayon Backing	Ultraleather
Fitzgerald Taupe F-0136609-03110010	Sofa, J-Lounge, Ensemble	47% Rayon, 34% Polyester, 19% Cotton	S
Circle Sonnet Scarlet	LR/BR/SE/Priv Lav Val, LR/BR Pillows, BR Shams, BR Chair	54% Polyester, 41% Wool, 5% Nylon	S
Rush Pond Scarlet	FSD, BR/Priv Lav Valances	47% Cotton, 44% Polyester, 9% Filament Rayon	S
Belanos 3140-2759-717	LR Pillows, LR/SE Valances	43% Rayon 34% Polyester 23% Cotton	S - Dry Clean
Dragon Eggplant	LR/BR/SE/Priv Lav Val, LR/BR Pillows, B'spread Accent, BR Shams	100% Silk	Dry Clean
Tiny Cubes Tuscan Red	Bedsread, BR Pillows, Bedsread Welt	65% Silk, 35% Cotton	S
Quilted Stripe Mahogany	BR Pillows	43% Polyester, 42% Olefin, 15% Cotton	S
Italian Weave-Saddle, REC22619F	Headboard	100% Polyester	Dry Clean
BCD0002063-01-A	Decorative Trim - Boucle Cord	51% Polyester, 37% Rayon, 12% Acrylic	S
CD0002063-01-A	Decorative Trim - Cord	44% Polyester, 41% Rayon, 15% Acrylic	S
Sensuede 9047 Sand	Ceiling Accent D	88% Polyester 12% Polyurethane	S - Dry Clean
Sensuede 0009 Cordovan	Ceiling Accent E	88% Polyester 12% Polyurethane	S - Dry Clean

BLACK COSMOS			
COLOR/PATTERN	APPLICATION	CONTENT	CODE
Tumbleweed Buff	J-Lounge, Euro-Recliner, Steering Wheel, Ensemble	Leather	Leather
Buff	Main Dash (Vacuumed)	Vinyl	Vinyl
Buff	Dash and Vinyl Accents (Wrapped)	Vinyl	Vinyl
Papyrus	Dash Insert	Vinyl	Vinyl
Johnson Cream	Windshield	100% Polyester	Dry Clean
Ultraleather Brisa Papyrus	Dr/Pass Chairs	100% Polyurathane Blend w/ 100% Rayon Backing	Ultraleather
Dabble, Rickshaw	Sofa, J-Lounge, LR/SE Val, Ensemble	20% Rayon Chenille, 50% Spun Rayon, 20% Polyester, 5% Nylon, 5% Cotton	S
Capital color Slate	LR Pillows, LR/SE Valances	35% Cotton, 31% Polyester, 24% Cotton Chenille, 10% Wool	S
Molfino, Olive	FSD, LR Pillows	34% Viscose Chenille, 34% Polyester, 21% Spun Rayon, 11% Cotton	S
Linton color 811 Suede	LR Pillows, LR/SE Valances	*Not available at time of printing.	*Not available at time of printing.
Kali color Earth	Bedsread, BR Pillows, BR/Priv Lav Valances	100% Silk	Dry Clean
Depiction color Ebony	LR/BR Pillows, BR Shams	87% Polyester, 13% Cotton	Dry Clean
Circle Sonnet, Tigereye	BR Pillows, BR Shams, Bedsread Welt, BR Chair, BR/Priv Lav Valance	54% Polyester, 41% Wool, 5% Nylon	S
Kali color Black	BR Pillows, BR/Priv Lav Valances, Bedsread Accent	100% Silk	Dry Clean
Ponderosa Onyx	Headboard	78% Polyvinyl Chloride , 22% Polyester	W
CD 1469 Fresco	Decorative Trim - Boucle Cord	72% Polyester, 28% Acrylic	S
CD 1469A Fresco	Decorative Trim - Cord	67% Polyester, 33% Acrylic	S
Sensuede 0050 Ebony	Ceiling Accent D	88% Polyester 12% Polyurethane	S - Dry Clean
Sensuede 9065 Latte	Ceiling Accent E	88% Polyester 12% Polyurethane	S - Dry Clean

* Not available at the time of print.

CEDAR GLADE			
COLOR/PATTERN	APPLICATION	CONTENT	CODE
Tumbleweed Kilimanjaro	J-Lounge, Euro-Recliner, Steering Wheel, Ensemble	Leather	Leather
Kilimanjaro	Main Dash (Vacuumed)	Vinyl	Vinyl
Kilimanjaro	Dash and Vinyl Accents (Wrapped)	Vinyl	Vinyl
Taupe	Dash Insert	Vinyl	Vinyl
Johnson Cream	Windshield	100% Polyester	Dry Clean
Ultraleather Brisa Kilimanjaro	DR/Pass Chair	100% Polyurathane Blend w/ 100% Rayon Backing	Ultraleather
Dane color Splash	Sofa, J-Lounge, LR/BR/SE/Priv Lav Val, Ensemble	20% Rayon Chenille, 50% Spun Rayon, 20% Polyester, 5% Nylon, 5% Cotton	S
SL-Smitten, Fresco #F-0149067-01100002	FSD, LR/SE Val., LR Pillows	16% Cotton, 35% Rayon, 49% Polyester	S
Duke of Bucclevch 5298-4986 color 5014	LR Pillows	55% Rayon, 29% Cotton, 16% Polyester	S - Dry Clean
Saki color Granite	Bedsread, BR/Priv Lav Valance, BR Pillows	60% Polyester, 40% Rayon	Dry Clean
Saki color Magic Moon	Bedsread Accent, LR/SE Valance, LR/BR Pillows, BR Shams	60% Polyester, 40% Rayon	Dry Clean
Treviso, Tranquil #f-0149239-01120020	BR/Priv Lav Valance, BR Pillows, BR Chair	52% Rayon, 48% Polyester	S
Streamer Stripe 8758-11271 color 6043	BR Pillows, Bedsread Welt, BR Shams	88% Polyester 12% Polyurethane	S - Dry Clean
Hula 580 Coffee	Headboard	100% Polyester	Not available at time of printing.
BCD 02967-01-A Teal Haze	Decorative Trim - Boucle Cord	50% Rayon, 43% Polyester, 7% Polypropylene	S
CD 02967-01-C Teal Haze	Decorative Trim - Cord	48% Polyester, 38% Rayon, 14% Polypropylene	S
Sensuede 9065 Latte	Ceiling Accent D	88% Polyester 12% Polyurethane	S - Dry Clean
Sensuede 9047 Sand	Ceiling Accent E	88% Polyester 12% Polyurethane	S - Dry Clean

2007 Ralph Lauren Fabrics:

Landsdown II

COLOR/PATTERN	APPLICATION	CONTENT	CODE
Leicester Col. 1 Cordovan	LR Pillows, LR Valance	50% Polyester, 32% Spun Viscose, 9% Acrylic, 9% Cotton	Dry Clean
Hewitt Herringbone Brown LCF-18585F (*.45d)	Sofa, LR Pillow, Opt. Euro-Recliner, Ensemble	100% Cotton	Dry Clean
Africana Dark Brown	Sofa Accent, J-Lounge Accent, Ensemble Accent	Leather	Leather
Terrazo Color 3 Walnut	FSD	60% Cotton 40% Polyester	Dry Clean
Houndstooth Cranberry LCF 14646F	LR Pillows	100% Cotton	Dry Clean
Amalfi Dark Brown	Dr/Pass Seat Welt, Sofa Accent, Opt. Sofa, Euro-Recliner, J-Lng, Sect Ensemble	Leather	Leather
Passport Sand	Driver/Passenger Chairs-Leather Section	Vinyl	Vinyl
Tracker II Passport Sand	Driver/Passenger Chairs-Vinyl Surround	Vinyl	Vinyl
Buff	Dash	Vinyl	Vinyl
Johnson Cream	Windshield	100% Polyester	Dry Clean
Palace Color 17 Cider	Bedsread Accent/BR Valance, BR Shams	39% Spun Viscose 35% Wool 22% Polyester 4% Nylon	Dry Clean
Glengariff Plaid Loden	Bedroom Pillow	100% Wool	Dry Clean
Vociferous 6 Lion	Bedskirt, BR Pillow, BR Shams, Bed Cushion	57% Polyester 43% Silk	Dry Clean
Kathleen Courtyard Floral Burgundy	Bedsread, BR Shams, BR Pillow	57% Linen 43% Cotton	Dry Clean
Fremont Stripe Burgundy LFY-20621-F	Bedroom Pillow, LR Pillow	100% Wool	Dry Clean
FRB-1171 Polo	Decorative Fringe	45% Polyester, 45% Acrylic, 10% Rayon	S
CD-1171 Polo Cord	Decorative Cord	48% Acrylic 43% Polyester 9% Rayon	S
BU-1171	Boullion Fringe	55% Acrylic 33% Polyester 12% Rayon	S
RST-1171	Decorative Tassel Button	47% Polyester, 38% Acrylic, 15% Rayon	S
Outback Ivory	Main Ceiling Vinyl	Vinyl	Vinyl
O' Vinyl Palomino	Ceiling Accent 1	88% Polyester 12% Polyurethane	S - Dry Clean
Raffia 3992 Sand Ultraleather	Ceiling Accent 2	88% Polyester 12% Polyurethane	S - Dry Clean
Sensuede 0009 Cordovan	Ceiling Accent	88% Polyester 12% Polyurethane	S - Dry Clean

BLACK PEARL			
COLOR/PATTERN	APPLICATION	CONTENT	CODE
Smithers Plaid LFY20394F	LR Pillows, LR Valance	100% Wool	Dry Clean
Escort 2 Seal	Sofa, J-Lounge, Opt. Euro Rec., Ensemble	61% Spun Viscose, 39% Polyester	Dry Clean
Classico Black Leather	Sofa/J-Lounge Surround, Euro Recliner, Sectional Ensemble	Leather	Leather
Richard Bernard Osterre Onyx	Sofa/J-Lounge Accent, Ensemble Accent	80% PVC, 20% Polyester	Dry Clean
Zebra Stripe Black	FSD	100% Cotton	S
Oceanside FR Silverwood	Driver/Passenger Chairs, Opt. J-Lounge	Leather	Leather
Milkweed	Dash	Vinyl	Vinyl
Johnson Cream	Windshield	100% Polyester	Dry Clean
Trianon Alabaster	BR Throw Rev. Side, Bedspread, BR Pillows	61% Spun Viscose, 39% Polyester	Dry Clean
Sandretto Licorice	Bedroom Throw	67% Cotton, 33% Silk	S
Monique 1 Black	BR Pillow, BR Valance., B'Spread Accent, Bed Seat Cushion	100% Acrylic	S
Cortes Plaid	BR Pillow	100% Cotton	Dry Clean
Laredo/B Black	Bedroom Pillow, LR Pillow	100% Wool	Dry Clean
FRB1344 Metallo Platinum	Decorative Fringe	100% Polyester	S
CD1479A Kona Coast	Decorative Cord	44% Polyester, 44% Acrylic, 10% Rayon, 2% Polypropylene	S
30224 Sterling Silver	Boullion Fringe	37% Rayon, 30% Polyester, 26% Acrylic, 7% Cotton	S
TS1789 Sterling Silver	Decorative Tassel	19% Polyester, 14% Rayon, 17% Acetate, 24% Polypropylene, 26% Chenille	S
Outback Ivory	Main Ceiling	39% Rayon, 22% Polyester, 22% Acrylic, 17% Cotton	S
O'Vinyl Papyrus	Ceiling Accent 1	88% Polyester 12% Polyurethane	S - Dry Clean
Ultraleather Raffia 3001 Durango Dust	Ceiling Accent 2	88% Polyester 12% Polyurethane	S - Dry Clean
Sensuede 501 Cedar	Ceiling Accent	88% Polyester 12% Polyurethane	S - Dry Clean

FLOORS

Carpet Cleaning

Spot Removal Procedures:

- ◆ Act quickly when anything is dropped or spilled. Remove spots before they dry.
- ◆ Blot liquids with a clean, white absorbent cloth or paper towel.
- ◆ For semi-solids, scoop up with a rounded spoon.
- ◆ For solids, break up and vacuum out as much as possible.
- ◆ Pretest the spot removal agent in an inconspicuous area to make certain it will not damage the carpet dyes.
- ◆ Apply a small amount of the cleaning solution recommended for the particular spot. **DO NOT** scrub. Work from the edges of the spot to the center. Blot thoroughly. Repeat until spot is removed.
- ◆ Follow steps on the Carpet Spot Removal Guide.
- ◆ After each application, absorb as much as possible before proceeding to the next step.
- ◆ Absorb remaining moisture with layers of white paper towels, weighted down with a non-staining glass or ceramic object.
- ◆ When completely dry, vacuum or brush the pile to restore texture.
- ◆ If the spot is not completely removed, contact a professional carpet cleaner.

Spot Removal Guide

Use the solution specified in order from 1-8 until stain is removed.	A	B	C	D	E	F	G	H	I
	DRY CLEANING FLUID	NAIL POLISH REMOVER	DETERGENT SOLUTION	WARM WATER	VINEGAR SOLUTION	AMMONIA SOLUTION	STAIN REMOVAL KIT	CALL PROFESSIONAL	PERMANENT CHANGE
SPOTS									
Acid				2		1		3	*
Acne Medication		1		2	5	4	3	6	*
Alcoholic Beverage			1	4	3	2			*
Ammonia				2	1				*
Bleach		1	2					3	*
Blood		1	3		2	4			
Candle Wax	1					2			
Cement & Glue	2	1	3		5	4	6		*
Chalk		1	2						
Charcoal		1	2						
Chewing Gum	1								
Coffee			1	3	2		4	5	*
Cosmetics		2	1	3	6	5	4	7	*
Crayon	1		2	3					
Drain/Toilet Cleaner			2	1	3			4	*
Dye	1		2		4	3	5	6	*
Food			1	4	3	2	5	6	*
Fungicides, Insecticides, Pesticides	1		2	5	4	3	6	*	
Furniture Polish (Water Based)			1	4	3	2	5	6	*
Furniture Polish (Solvent Based)	2	1	3	6	5	4	7	8	*
Furniture Stain	2	1	3	6	5	4	7	8	*
Graphite		1	2						
Grease	1	2	3				4	5	*
Ink	2	1	3	6	5	4	7	8	*
Iodine	1		2	5	4	3	6	7	*
Lipstick	2	1	3	6	5	4	7	8	*
Medicine	2	1	3	6	5	4	7	8	*
Merthiolate			1	4	3	2	5	6	*
Nail Polish	2	1	3				4	5	*
Oil	1		2	4		3		5	*
Paint	2	1	3				4	5	*
Plant Food			1	4	3	2	5	6	*
Rust			2	3	1		4	5	*
Shoe Polish	2	1	3	5		4	6	7	*
Soft Drinks			1	4	3	2	5	6	*
Soot	1		2	3				4	*
Tar	1						2	3	*
Toothpaste			1						
Urine			1		2		3	4	*
Vomit			1	4	3	2	5	6	*

* While recommended cleaning agents are effective, some stains may become permanent.

Cleaning Solutions:

- A. Dry Cleaning Fluid:** A nonflammable spot removal liquid, available in grocery and hardware stores.
- B. Nail Polish Remover:** Any acetate, which often has a banana fragrance. **DO NOT** use if it contains acetone.
- C. Detergent Solution:** Mix two cups of cold water and 1/8 teaspoon mild liquid detergent (no lanolin, non-bleach).
- D. Warm Water:** Lukewarm tap water.
- E. Vinegar Solution:** One cup white vinegar to one cup water.
- F. Ammonia Solution:** One tablespoon household ammonia to one cup water.
- G. Stain Removal Kit:** Available from retail carpet stores or professional cleaners.
- H. Call Professional:** Additional suggestions, special cleaning chemicals or the ability to patch the area may be available.
- I. Permanent Change:** Due to the nature of the stain, there may be color loss. The carpet has been permanently dyed or the carpet yarns have been permanently damaged.

NOTE:

While the recommended cleaning agents have proven to be effective, some stains may become permanent.

Tile Floor

Tile floors vary in porosity and surface irregularities. Regular maintenance is important to keep the tile in the motorhome looking showroom new. Once the slide-out has been extended, keep the tile floor clean to prevent dirt from scratching the tiles prior to retracting the slide-out.

NOTE:

Tile is ceramic and will chip or break. Avoid dropping heavy or sharp objects on the tile.

Cleaning Tile:

Use a damp sponge mop or a cloth to clean tile. If moderate staining occurs, cleaning with a window cleaner such as *Windex*® should do the job. A mild solution of hot water and all-purpose cleaner for tile floors, walls and countertops can also be used. Rinse well with clear water and dry with a soft cloth to prevent streaking. Avoid cleaning tile with soap. Soap forms a film to dull the luster. Soap also promotes the growth of mildew and bacteria. **DO NOT** use powdered cleaners on unglazed tile floors. Undissolved powder will dull the surface. Grout sealers are available that protect the porous surfaces. If a sealer is used, follow the sealant manufacturer guideline for application. Never use sealers on unglazed tile. With the exception of terra cotta, which may be oiled or waxed, tile does not need to be polished or buffed to maintain its finish.

NOTE:

Before using any solution to clean the tile, check the manufacturer's warning label to ensure safety of the product. If there is any doubt, apply several test patches of the solution in an inconspicuous place to determine product suitability.

Grout:

Grout used is a two part concrete mix and can develop surface cracks over time. In motorhome application, due to the constant flexing of the flooring, this process may accelerate. If the grout requires cleaning, scrub with a plastic brush. **DO NOT** use steel wool as small particles may remain and produce unsightly stains.



050250d

Sealing the Tile:

Apply sealant to the tile floor and grout to prevent discoloring from soils and spills. One pint of 511 Impregnator sealer, provided with the motorhome, is sufficient to seal the floor. Follow application instructions carefully.

CAUTION:

Product contains petroleum distillate. Open windows, vents and doors to provide adequate airflow during application.

NOTE:

It is recommended to test a small amount of sealant on an inconspicuous area before applying to the entire floor. Avoid getting sealant onto surfaces other than the flooring.

To Apply:

1. Extend slide room(s) and clean floor. Allow floor and grout to thoroughly dry.
2. Working from rear towards doorway, apply sealant direct from container onto a cloth towel or broom handle applicator. Grout sealant applicators are available at large hardware stores.
3. Apply only enough sealant to wet surface. **DO NOT** allow sealant to puddle in grout lines. Extra care should be used to make sure all grout has been sealed. Only one application is necessary.
4. Allow five hours to dry. Sealant will fully cure in 72 hours.

NOTE:

If a spill occurs before sealant has cured, it may be necessary to clean and additionally treat area with sealant as needed.

Laminate Floor (Optional)

Laminate flooring used in the motorhome provides style, durability and ease of maintenance. This high-pressure laminated flooring is designed to be incorporated as a floating floor.

Laminate flooring is constructed of three main material components. The surface, similar to many countertops, contains aluminum oxide particles to form an extremely hard, durable outer layer. The carrier, or core layer, is constructed from high density fiberboard. A tongue and groove design provides a tighter bond. The backer or bottom layer is also made of laminate for strength.

Cleaning and Maintenance:

For everyday cleaning, vacuum the floor to remove dirt and debris. It is recommended to occasionally mop the floor using a cotton string mop and a minimal amount of water. Use a mixture of soap-free household cleaner (either vinegar or ammonia work well) and water for a more thorough cleaning.

SHOWER

Showers are susceptible to soap build-up. To control mildew growth, spray the shower with household chlorine bleach. Allow it to stand for five minutes, then rinse with clear water. Clean the glass shower doors with window cleaner on a weekly basis to maintain shine. If water spots cannot be removed from glass, rub lightly with the flat edge of a razor blade to remove deposits.

To prevent excessive moisture and a continual growth of mildew, use the shower only with adequate ventilation. The sealant in a regularly used shower should be replaced once a year. To replace sealant, remove the old sealant using a sharp non-metallic instrument. Apply a new sealant, which can be found at most recreational vehicle supply stores.

CEILING

The ceiling of the motorhome can be a variety of materials or fabrics:

Hardwood, Vinyl and Decorated Paneling:

Certain cleaning agents will affect the surface on both printed and unprinted vinyl. Use only a mild, non-abrasive detergent and warm water with a soft cloth or sponge to clean. **DO NOT** use bleach, alcohol, oil-based spray cleaners or cleaning agents that contain solvents, citrus oil or harsh chemicals.

Decorative Ceiling Mirror:

Household cleaners, ammoniated detergents or glass cleaners may be used on A-Look Decorative Metals. Use a glass cleaner applied to a soft cloth to clean.

Suede Fabric:

Restore surfaces using a soft brush. Remove dust from the suede fabric using the soft brush attachment of a vacuum.

Lumicor:

Clean using warm water, mild detergent, and a soft sponge, cloth, or chamois.

WALL COVERINGS

Immediately remove solvent based or pigmented substances from wall coverings. **DO NOT** use abrasive cleaners containing chlorine bleach or solvents. Fidelity and Jolie brands are recommended. Always begin with a mild detergent or soap and warm water. To remove normal dirt, clean with a soft sponge. Rinse and wipe dry.



Care for the Tower Wall Covering:

Remove ordinary stains with mild soap and warm water. Sponge on. Rinse well and dry with a soft cloth. To remove ball point pen, blood, lipstick, etc., use a sponge or soft bristle brush and *Formula 409*®, *Fantastik*® or a similar product. Rinse well and dry. Finish cleaning by applying full strength isopropyl alcohol with a sponge or soft brush. Rinse well and dry.

Care for the Satinesque Wall Covering:

Remove stain quickly to minimize the reaction on the wall covering, especially if the stain is solvent-based or pigmented. **Examples:** nail polish, oil, shampoo, lacquer, enamel, paint, ink and lipstick.

Begin cleaning the stain with a mild soap-based detergent; and if necessary, move to a stronger cleaner such as household bleach, liquid household cleaners or rubbing alcohol. Before applying a stronger cleaner, test the cleaning agent on a small inconspicuous portion of the wallcovering to ensure the cleaner does not affect the color or gloss of the wall covering.

Stain Removal Procedures for Specific Stain Types:

Normal Dirt:

Remove normal dirt using a mild soap or detergent and warm water. Allow it to soak for a few minutes then rub briskly with a cloth or sponge.

Nail Polish, Shellac or Lacquer:

Remove liquid using a dry cloth. Use care not to spread the stain. Quickly clean the remaining stain with rubbing alcohol. Rinse with clean water.

Ink:

Remove immediately by wiping with a cloth dampened in rubbing alcohol. Rinse with clean water.

Chewing Gum:

Rub with an ice cube to cool and harden. Gently pull off the bulk of the gum. Remove remaining gum with rubbing alcohol.

Pencil:

Erase as much of pencil mark as possible. Wipe remaining marks with rubbing alcohol.

Blood, Feces or Urine:

Remove these staining substances as quickly as possible. Wash the stained area with a strong soap. If the stain does not disappear, rinse the soapy area thoroughly with clean water. Mix a solution of 50% water and 50%

household bleach. Clean the stained area with the bleach solution. Rinse with clean water.

WOOD CARE

For general cleaning, regularly wipe wood surfaces using a soft cloth lightly dampened with clear warm water, and thoroughly dry to prevent streaking. For stubborn stains, use a clean cloth dampened with a solution of mild non-alkaline soap (dishwashing liquid) and water and rinse. Dry thoroughly, buffing in the direction of the wood grain. Never use abrasive cleaners, scouring pads or powdered cleansers. Polishing products used on the solid wood surface depends on individual preference. Always follow product instructions.

Excessive dampness, dryness, heat, or cold can damage solid wood finishes. Sunlight can change the color or age the wood. Never allow moisture or spills to stand, always blot dry immediately. Solvents, alcohol, nail polish and polish removers, as well as harsh cleaners, should not be used on finished wood surfaces.

Minor damage to solid wood surfaces can be repaired quickly and effectively with a bit of hard work, some careful attention to details, and most importantly, the right materials. However, any wood repair or finishing job is best left for a professionally trained individual.

NOTE:

It is important to inform the service technician of any products used for the care and cleaning in the event of wood repairs.

Sanding and Sandpaper:

The following table is a general guide, but this may vary with wood type. The key to sanding is using the right sandpaper for the repair that is needed. Always sand with the grain.

GRIT	GRADE	USE
80-120	Medium	Smoothing the surface, removing small marks.
150-180	Fine	Final sanding prior to finishing.
220-240	Very Fine	Sanding between coats of sealing.
280-320	Extra Fine	Removing dust spots or mark between finish coats.
360-600	Super Fine	Removing luster or surface blemishes.

Steel Wool:

Abrasive material composed of long steel fibers of varying degrees of fineness that are matted together. Coarser grades are used to remove paint and other finishes; the finer grades for polishing or smoothing a finished surface.

Nail Holes and Small Cracks:

Fill nail holes and small cracks with wood putty or dough for unstained woods prior to any sanding. Stained finishes require filling holes and cracks after the stain has been applied. Putty should match the stain closely in color.

TIP:

A little sawdust and wood glue can be used to make putty for end grains.

Scratches and Nicks:

“Quick and simple” rarely describes repairs to stained wood finishes; however, a few tricks used by professional woodworkers can be tried to repair nicks and scratches.

Fixing scratches in stained woodwork:

Light scratches will often disappear when carefully rubbed with furniture polish or paste wax. When scratches appear lighter than the surrounding dark-stained woodwork, it usually means either that the scratch goes through the stain into the wood or that the varnish is flaking off. Deeper scratches can be hidden by carefully rubbing with a piece of oily nut meat such as Brazil nut, black walnut or pecan. Be careful to rub the nut meat directly into the scratch to avoid darkening of the surrounding wood. Color the scratch with brown coloring crayon or liquid shoe dye (especially good on walnut). Always test a procedure on an inconspicuous area on the wood to ensure no damages to the finish occurs.

Staining the scratch with iodine:

Mahogany - Use new iodine.

Brown or Cherry Mahogany - Use iodine that has turned dark brown.

Maple - Dilute one part iodine with one part denatured alcohol.

Commercial scratch removers, or stick wax to match the wood finish, can also be used. After the scratch has been hidden, polish or wax the entire area. Deep scratches should be repaired and finished by a professional.

Dents:

Small dents may be repaired by using steam. To raise a small dent, place a damp cloth over the area and hold a medium-hot iron on it. The steam causes the wood fibers to swell back into place. It may be necessary to repeat this process until the dented area is level with the surface. Allow the area to dry.

Restoring the clear finish:

Check the scratches carefully. If flaking varnish is visible with dark-stained wood underneath, only the clear finish may need to be restored. Rub the loose varnish with fine steel wool or fine synthetic steel wool until you have removed the flaking varnish and slightly roughened a small area of the finish surrounding the scratch. With the tip of a rag, a small brush, or even a cotton swab, apply a thin coat of wipe-on finish. Apply finish to the damaged area only. Several coats may be needed to hide the scratch.

Re-staining the wood:

If bare wood is visible at the bottom of the scratch, the wood will need to be re-stained. To remove damaged varnish, lightly roughen a small area around the scratch with sandpaper, steel wool or synthetic steel wool. Find a stain that is a shade lighter than the wood finish. Stain the bare wood with a very small amount of stain on a rag, brush or cotton swab. If the color is too light, apply additional coats. Rub away excess stain with a dry rag. If the wood becomes too dark, use a rag moistened in mineral spirits to lighten the wood. Select a lighter color stain and continue.

Several companies have simplified this repair process by designing oil-based wood stain into marker-like containers to rub on to the scratch. Torn and scratched wood fibers will absorb stain and darken quickly. Start with a stain color that is lighter than the original finish. A second coat can always be applied if the color of the first coat is too light. Once the color is blended, patch the clear finish as described above and apply a wipe-on finish.

COUNTERTOPS

Solid Surface

Routine Care:

The motorhome solid surface countertops and sinks have a matte/satin finish. Soapy water or ammonia-based cleaners will remove most dirt and stains from all tops and bowls. Individual techniques may be used to remove different stains. Follow the recommendations below.

Cleaning the Countertops:

- ◆ **Most dirt and stains:** Use soapy water or ammonia-based cleaner.
- ◆ **Water marks:** Wipe with damp cloth and towel dry.
- ◆ **Difficult stains:** Use soft scrub and a Grey Scotchbrite Pad.
- ◆ **Disinfecting:** Occasionally wipe surface with diluted household bleach (one part water and one part bleach).

Cleaning the Solid Surfaces Sink:

Occasionally clean by using Soft Scrub Liquid Cleanser and a Grey Scotchbrite pad. Scrub the sink, rinse and towel dry.

Removing Cuts and Scratches:

Solid Surface countertops are completely renewable. Use the following instructions to remove minor cuts and scratches.

- ◆ Sand area starting with 180 grit sandpaper, working your way up to 2000 grit or until blemish is gone and renewed finish is achieved.
- ◆ Never sand in one small area. Feather out lightly at each increase in sandpaper grit to blend restoration.

Preventing Heat Damage:

Hot pans and heat-generating appliances, such as frying pans or crockpots, can damage the surface. To prevent heat damage, always use a hot pad or a trivet with rubber feet to protect the surface.

Other Important Tips:

Avoid exposing the solid surface to chemicals such as paint removers or oven cleaners. If these chemicals come in contact with the Solid Surface, quickly wash with water. Avoid contact with nail polish or nail polish remover. If contact is made, quickly wash with water.

NOTE:

DO NOT cut directly on the solid surface. When pouring boiling water into the Solid Surface sink, run the cold water faucet to dilute the excess heat.

STAINLESS STEEL SURFACES

Clean stainless steel once a week with a damp sponge. Apply stainless steel cleaner/polish with the grain, not across, using a non-abrasive cloth or sponge. **DO NOT** use steel wool, wire brushes or abrasive sponge pads. These will mar the finish. Cleaner containing chloride is not recommended; however, if used, thoroughly rinse the surface to prevent corrosion. To avoid water spots, **DO NOT** allow water to evaporate on the surface.

WINDOWS

Water Spots:

Glass will develop water spots when not properly cleaned. Water spots are magnified on a reflective finish. Use a squeegee immediately after washing to reduce water spotting. To remove stubborn water stains from reflective glass we recommend Cerium Oxide Polishing Compound, made by C.R. Lawrence, available at most glass shops.

Condensation

Condensation occurs from water vapor present in the air. More vapor is added by breathing, bathing, cooking, etc. and collects wherever there is available air space. When the temperature reaches the dew point, the water vapor in the air condenses and changes to liquid form.

Controlling Moisture Condensation:

Reduce or eliminate interior moisture condensation during cold weather by using the following steps:

- ◆ Partially open the roof vents and windows so that outside air can circulate into the interior. Increase the ventilation when large numbers of people are in the motorhome. Even in raining or snowing conditions the air outside will be far drier than interior air.
- ◆ Install a dehumidifier. Continuous use of a dehumidifier is effective in removing excess moisture from interior air. Using a dehumidifier is not a cure-all, however, it will reduce the amount of outside air needed for ventilation.
- ◆ Run the range vent fan when cooking and the bath vent fan (or open the bath vent) when bathing, to reduce water vapor. Avoid excessive boiling or use of steam producing hot water.
- ◆ **DO NOT** heat the motorhome interior with the range or oven. Heating with the range or oven increases the risk of toxic fumes and depletes oxygen. Open flames also add moisture to the interior air and increase condensation.
- ◆ In very cold weather, leave cabinet and closet doors partially open. Air flow will warm and ventilate the interior storage compartments and exterior walls to reduce or eliminate condensation and prevent the possibility of ice formations.

WINDOW TREATMENTS**Mini-Blinds****Dusting:**

Regular dusting will maintain the appearance of the mini-blinds. Keep aluminum blinds looking their best by periodically wiping with a soft cloth or a dusting mitt. By tilting the slats down, not quite closed, most of the top surface of each slat can be cleaned. Blinds may be cleaned while hanging in place using this method.

Vacuuming:

For deeper cleaning, vacuum gently with the soft brush attachment of a vacuum cleaner.

Compressed Air or Hair Dryer (non-heat setting):

Blow dust off each slat. Dust will be air-borne using this method so ventilate the motorhome.

Spot-Cleaning:

Spot-clean shades and blinds using a soft cloth or a moistened sponge with lukewarm water. Add mild detergent, if needed. Blot gently to avoid creasing. In a dusty environment, the blinds may need to be cleaned regularly using a sponge or dampened soft cloth. Use warm (not hot) water and a mild detergent that does not contain abrasives. Rinse the blinds using a clean cloth and water to prevent water spots. Place a towel directly under the blinds to absorb water that may drip.

Ultrasonic cleaning:

Professional ultrasonic cleaning may be preferred.

Day/Night Shades**Guidelines for care and maintenance of polyester blended day/night shades:**

- ◆ Leave Day-Night shades in the up position when not in use to help the shades hold their shape.
- ◆ String tension for the shades should be equal.

Dusting:

Vacuum with a brush attachment or use a dusting tool on a regular basis.

Cleaning:

A dry foam cleaner may be used for soil and dirt removal. Follow all directions on the container, or a cleaning solution of ¼ ounce clear liquid soap to 8 ounces water.

NOTE:

DO NOT use colored liquid soap as a stain may appear when fabric dries.

MOLD & MILDEW

What is Mold?

Mold is a type of fungus that occurs naturally in the environment and can leave a musty odor, discolor fabrics, stain surfaces and cause considerable damage to the motorhome.

What Does Mold Need to Grow?

Mold requires a food source to grow such as grease or soil. Synthetic fabrics, such as acetate, polyester, acrylic and nylon, are mildew resistant, but soil on the surface of these fabrics are susceptible to mold.

Temperate climate and moisture also help to cultivate mold growth. Moisture in the motorhome can result from unattended spills, leaks, overflows and condensation. Moisture allowed to remain on a growth medium can develop mold within 24 to 48 hours. Minimizing moisture inside of the motorhome can reduce or eliminate favorable mold growth conditions. Good housekeeping and regular maintenance are essential in the effort to prevent or eliminate mold growth.

Consequences of Mold:

All mold is not necessarily harmful, but certain strains of mold have been shown to cause, in susceptible persons, allergic reactions, including skin irritation, watery eyes, runny nose, coughing, sneezing, congestion, sore throat and headache. Individuals with suppressed immune systems may risk infections. Some experts contend that mold causes serious symptoms and disease which may even be life threatening. However, experts disagree about the level of mold exposure that may cause health problems, and about the exact nature and extent of the health problems that may be caused by mold. Moreover, the Center for Disease Control states that a casual link between the presence of toxic mold and serious health conditions has not been proven.

Standards or threshold limit values for concentration of mold or mold spores have not been set. Currently, there are no EPA regulations or standards for airborne mold contaminants. There is simply no practical way to eliminate all mold and mold spores in the indoor environment. For example, studies have shown that ozone cleaners are not effective at killing airborne mold or surface mold contamination.

Controlling Mold Growth:

The motorhome owner should eliminate mold growth in the motorhome. Take the following steps to eliminate mold growth in the motorhome:

1. Carefully examine items for signs of mold before loading them in the motorhome. Potted plants (roots and soil), furnishings, clothing and linens, as well as many other household items, may contain mold.
2. Regular vacuuming and cleaning will help reduce mold levels. Mild bleach solutions and most tile cleaners are effective in eliminating or preventing mold growth.
3. Indoor humidity can be reduced by 30 to 60% when venting clothes dryers to the outdoors. Ventilate the kitchen and bathroom by opening windows, using exhaust fans or a combination of both. Operating the air conditioning will remove excess moisture in the air, and help facilitate evaporation of water from wet surfaces.
4. Promptly clean up spills, condensation and other sources of moisture. Thoroughly dry any wet surfaces or material. **DO NOT** let water pool or stand in the motorhome. Promptly replace materials that cannot be thoroughly dried.

5. **Inspect** for leaks on a regular basis. Look for discolorations or wet spots. Repair leaks promptly. **Inspect** condensation pans (refrigerators and air conditioners) for mold growth. Take notice of musty odors and any visible signs of mold.
6. Should mold develop, thoroughly clean the affected area with a mild solution of bleach. First, test to see if the affected material or surface is color safe. If mold growth is severe, call on the services of a qualified professional cleaner.
7. If mold cannot be removed from an item, throw the item away.

Whether or not a motorhome owner experiences mold growth depends largely on how the motorhome is managed and maintained. As a manufacturer, our responsibility is limited to things that we can control. As explained in the written warranty, we will repair or replace defects in the construction (defects defined as a failure to comply with reasonable standards of motorhome construction) for the Limited Warranty coverage period provided. **THE MANUFACTURER WILL NOT BE RESPONSIBLE FOR DAMAGE CAUSED BY MOLD THAT MAY BE THE CONSEQUENCE OF OR ASSOCIATED WITH DEFECTS IN THE CONSTRUCTION.**

PEST CONTROL

Regardless of the area one lives in or travels to, it is safe in stating there will be pests waiting. These pests are not only annoying; they can pose a health risk and create serious damage to the motorhome.

- ◆ Common pests include insects such as ants, cockroaches, termites, flies, pantry pests and wasps as well as wildlife such as rodents, raccoons, bats, birds and snakes. It is important to remember that pests are searching for food, water and a place to live. Eliminating any one of those elements will help control the pest infestation. Take immediate steps to remove pests as soon as their presence is detected.

Steps to help control pests:

- ◆ Reduce clutter inside the motorhome and storage bays. All storage items, particularly food (including pet food), should be kept in tightly sealed containers. Seal all cracks and holes, and insure that window, door and vent screens are securely in place.
- ◆ Routinely clean the motorhome, including storage bays. Wipe down the water bay. Promptly remove all crumbs from areas where food is regularly prepared and eaten. Garbage should be placed in a sealed container and removed to an outside receptacle daily. Only put out pet food that will be immediately eaten.

- ◆ Keep foods such as flour, cereal, spaghetti and pet food in re-sealable containers with tight lids.
- ◆ Sweep and vacuum often (especially in eating areas) to help eliminate a food source for pests.
- ◆ Seal cracks, crevices, and gaps around doors and windows.
- ◆ Many pests need moisture to successfully live and reproduce. Limit their access to water or moisture sources by sealing any cracks and leaks in pipes and faucets. Reduce moisture in the motorhome by controlling condensation, immediately wiping up spills and promptly repairing leaks. Be extra alert around areas that attract rodents and insects, including the sewer hose, fresh water hose, bay doors and items that may be leaning against the outside of the motorhome, such as fishing poles and golf clubs.
- ◆ When the motorhome is stored outdoors, clear the surrounding area of all rodent friendly hiding places: shrubs, trees and clutter. Completely seal the underside of the motorhome. Wire mesh will work well to prevent points of entry, but beware of blocking necessary air vents. Prior to operating the motorhome after storage, remove all insect and animal nests that may have developed around vents, engine compartments, the exhaust pipe and in the wheel wells.

Rodents:

Rodents may chew through wires or build nests in components of the motorhome. Signs of rodent infestation include droppings, shredded material or chewed furniture fabrics and vinyl. Rodents like to build nests with wire insulation, and are commonly attracted to the outside coating of 120 Volt AC wiring more than 12 Volt DC wiring.

NOTE:

Although the back cap of the motorhomes is well sealed, rodents are capable of chewing through the foam insulation and that area should be routinely inspected.

If there are signs of rodent infestation around the motorhome, place traps or poisons in suspected areas. Keep the traps and poisons safely away from pets and children. Cheese is not the best bait for a rodent trap. Use peanut butter or chocolate in small amounts. Place the bait on the trigger of the trap to induce the rodent to climb onto the trigger to reach the bait. Rodents do not limit invasion to unused vehicles.

Insects:

Eliminate insects when signs of infestation appear. If you are unable to identify the type of insect, purchase sticky traps from the hardware store and place the tape where the insects have been seen. Once a sample is caught, seek assistance in identifying the insect to determine what will be required to remove the infestation.

Regularly **inspect** the exterior of the motorhome for signs of a budding wasp nest, and promptly destroy small nests before they become too large.

Spiders can be in any structure. Immediately remove spider webs. Some types of spiders like to nest on top of the diesel tank and around the diesel hoses. Dispense of spiders using a vacuum. Use care to capture the spider and egg sacs. Throw the vacuum bag away in a sealed bag.

Fruit flies invade the motorhome by attaching to fresh fruits and vegetables. Determine what food items are generating the flies and discard that item in an outdoor trash receptacle. Fruit flies can be eliminated with a homemade trap. Pour a few ounces of vinegar into a cup and cover the cup with plastic wrap. Secure the wrap with tape or a rubber band and poke a ¼" hole in the plastic. Place the trap in the area where fruit flies are present.

Ants live in colonies. Only a fraction of the ant colony will leave to seek food. Spraying pesticides will only kill the ants that are away from the colony. The colony must be destroyed to eliminate all ants. Keep ants away from the sewer hose by spraying the hose ends with a soap and water solution.

Fleas can be removed by properly treating pets with a veterinarian approved treatment and by thoroughly cleaning the motorhome. Vacuum vinyl areas and tile floors to remove dust, flea larva and flea eggs. Follow by thoroughly washing those areas with soap and water. Carpets must be vacuumed and treated with a residual flea control product labeled safe for indoor carpet and furniture use. Perform the cleaning treatment daily for three days to ensure that all fleas have encountered the treatment.

Flying outdoor insects are attracted to bright light. Yellow porch light covers on the motorhome work to discourage insect invasion. During nighttime hours insects will be attracted to docking lights, or other bright exterior lighting.

If the presence of moths is detected inside of the motorhome, usually by holes appearing in material, clean the affected clothing and all other items stored in the same area. Follow by completely cleaning the closet, dresser or storage area. If cracks are detected, seal the cracks and treat the area with a properly labeled indoor pest control product.

Birds:

Even birds can be considered pests, particularly when the motorhome is parked in the flight path of a flock. Bird droppings are hard to remove and will leave stains. Prevent permanent staining to the motorhome roof by regularly cleaning the surface to remove all bird droppings.

Damage from Pests:

Lizards have been known to crawl into the inverter and short out the circuit board. Lizards can be captured using glue traps. To remove the lizard from the trap, dissolve the glue with vegetable oil and release it outside and well away from the motorhome. A scorpion will glow blue-green in UV light. If the presence of scorpions in the motorhome is suspected, investigate with an UV black light during the nighttime hours.

Best sources of information about common household pests:

The Internet is a great place to find information about common pests. The National Pest Management Association website can be useful resource about common pests. Another good source for information are colleges and universities with entomology (study of insects) departments.

Electronic pest control devices can be costly and most likely will not work on all types of rodents and insects. When calling on the services of a professional to combat pest infestation, call a reputable business that is licensed in handling pesticides. Check references. Explain that you are seeking assistance for a motorhome, as treatments may differ from standard household jobs.

If a pest problem is suspected in the motorhome, consider professional pest control help. The following guidelines can be used for selecting a pest control service:

- ◆ Seek referrals from those who have used pest control services. Inquire about the type of pest problem encountered and if they were satisfied with the service.
- ◆ Membership in the national, state or local pest control associations is a good indicator that the company has access to modern technical information and is committed to further education.
- ◆ Reach a complete understanding with the company before work starts; find out what the pest is, how the problem will be treated, how long the period of treatment will be, and what results can be expected.
- ◆ Be sure to understand what is guaranteed and what is not.

STORAGE
Short Term

Short term storage is defined as storing the motorhome for a period of thirty days or less. Properly preparing the motorhome during periods of short term storage will make bringing the motorhome out of storage a much easier process. Winterize the plumbing system if the motorhome is stored in winter months, or if stored when temperatures are below 32° F.

Checklist - Short Term Storage:

- ◆ Retract the slide rooms. **DO NOT** store the motorhome with slide rooms extended.
- ◆ Shut off all appliances. Close the primary LP-Gas valve.
- ◆ Remove all articles from refrigerator/freezer and clean thoroughly.
- ◆ If equipped with residential refrigerator, drain icemaker and icemaker tray. See manufacturers manual for more details.
- ◆ Prop doors open to prevent mildew.
- ◆ Holding tanks should be drained and fresh water system winterized with potable antifreeze and winterize the plumbing system using air pressure.
- ◆ Retract and secure all awnings.
- ◆ Turn **OFF** the interior house power.
- ◆ Cancel the Automatic Generator Start program.
- ◆ Batteries should be stored fully charged. Batteries stored in a discharged state will readily freeze.

- ◆ If possible, position the motorhome so the batteries are accessible for charging or changing without having to move the motorhome.
- ◆ If available, leave the motorhome hooked to shore power. Leave the main battery disconnect switches **ON**.
- ◆ Careful placement of a small heat source in the interior will help control moisture. Desiccate filter systems will help remove interior moisture.
- ◆ If AC power is not available, turn the chassis battery disconnect switch **OFF**.
- ◆ If possible, store the motorhome inside a storage building.
- ◆ If stored outside, **inspect** all seams and seals twice a month for possible leakage.
- ◆ Store the motorhome with a full fuel tank to minimize moisture condensing at top of fuel tank.
- ◆ Vents and windows should be closed to prevent wind driven rain entrance.
- ◆ Tires should be stored at maximum inflation pressure.
- ◆ Perform a full interior **inspection** for water leaks twice a month. Be sure to check behind all cabinet doors and drawers.

Long Term

Long term storage of the motorhome can be defined as leaving a motorhome unattended for a period of thirty days or more. A motorhome requires protection from the elements just as a house or a car would. When left out in the environment without proper storage or maintenance, a motorhome, house or car is vulnerable to the moisture and oxidation processes inherent in the environment.

NOTE:

The natural process of condensation will occur with temperature changes of 30° F or more in one day. Humidity readings of 60% or greater will allow the accumulated moisture to remain for extended periods of time.

If AC power is not available in storage area:

- ◆ Turn **OFF** all appliances.
- ◆ Turn **OFF** interior house power using the battery cut-off switch.
- ◆ If possible, situate the motorhome so the batteries remain accessible. This allows a battery to be charged or replaced without moving the motorhome.
- ◆ Charge the batteries to a full state of charge.
- ◆ Cancel the Automatic Generator Start program.
- ◆ Turn the main battery disconnects **OFF**.

- ◆ When stored outside, use the Aladdin™ system to make a quick reference check of the battery voltage while the motorhome is in storage. If the motorhome is stored outside, solar panels may offset the parasitic loads. Preventative measures should be used if the voltage readings are low. Removing the motorhome from storage or moving the motorhome in case of an emergency will be a much easier process.

NOTE:

Batteries in a low state of charge will readily freeze. Freezing will damage the battery.

If AC power is available:

The main battery disconnect switches should remain **ON**. The inverter will charge both house and engine battery banks. A 30 Amp shore power service will be more than adequate.

CAUTION:

A 20 Amp service using light duty extension cords and the required adapters create serious voltage losses. Line voltage loss and the resistance at each electrical connection is a hazardous combination and should be avoided. Damage to sensitive electronic equipment may result!

Type of surface to park and store the motorhome on:

- ◆ Avoid parking the motorhome on a grass or gravel surface to prevent moisture accumulation.
- ◆ Concrete pads seal the surface and allow better ventilation under the motorhome.
- ◆ Storage buildings with concrete floors, or heated storage facilities, greatly reduce the amount of moisture accumulation and protects the motorhome from moisture damage.

Outdoor Storage Area:

- ◆ The interior should be heated to help prevent mold and mildew growth. Moisture removing desiccate filter systems are available from hardware and RV supply stores. Place the filter system inside the motorhome to reduce interior moisture condensation or humidity.
- ◆ Proper winterization of the fresh water system will prevent potential damage in extreme cold.
- ◆ Ultraviolet radiation affects soft goods and rubber products such as privacy curtains, window shades and tires. These items should be protected. Store Day/Night Shades in the Up position.
- ◆ Cardboard templates can be made for the windows to protect the interior from exposure to direct sunlight.
- ◆ Tire covers are available to protect the sidewall of the tires from cracking. Make sure tires in storage contain the correct air pressure to prevent damaged caused by underinflation.

- ◆ Regularly wash the exterior to help control moss accumulation. Waxing the motorhome twice a year will augment these substances.

Inspect the motorhome:

- ◆ Perform a full interior **inspection** for water leaks every two weeks while the motorhome is in storage. Check inside all cabinets for signs of dampness or leaks. **Inspect** the ceiling areas around roof vents or other roof openings.
- ◆ The roof and sidewall seams should be inspected and cleaned at least twice a year. **Inspect** for exterior sealant gaps of all roof seams, vents, skylights, roof air conditioners and windows.

Fuel:

Storing the motorhome with a full fuel tank will minimize moisture condensing at the top of the tank. Diesel fuel is an organic material which will develop a microbe growth (black slime). Fuel stabilizers may be added to control microbe growth and degrading of the fuel. Consult the engine manufacturer's owner's manual or a distributor for further detailed information on fuel stabilizers and additives.

Brakes:

Brakes suffer from non-use during periods of storage. The bare metal machined surfaces of brake drums or rotors have only a light coating of dust from the brake lining friction material. The brake dust is the only thing protecting the bare metal surfaces from rusting. Only regular brake applications dry the moisture preventing rust on brake drum or rotor surfaces. During

periods of non-use, oxygen and moisture oxidize the machined surfaces. Only occasional use keeps these surfaces from oxidizing. Rusty brake drum or rotor surfaces permeate the brake lining upon the first few applications, reducing the friction action of the linings.

Engine:

Internal combustion engines need to be "exercised" on a regular basis to ensure an adequate supply of lubricating oil coats the cylinder walls and piston rings. Valve and valve seat surfaces also suffer from non-use. Some valves will remain open depending at which part of the combustion cycle the engine has stopped. The heat and cold of the day allows moisture to accumulate through the exhaust system. Start all engines at least twice a month.

Electric Motors:

Electric motors in the motorhome should be occasionally operated to help lubricate and keep surfaces freely rotating. These items include the roof air conditioners, dash fans, dash blower motor, Aqua-Hot motors, heat exchangers and powered roof vents.

Winter Storage Checklist

- ◆ **Plumbing Lines** - Drain and protect. (See *Winterizing - Section 6*)
- ◆ **Fresh Water Tank** - Drain.
- ◆ **Body** - Clean and wax. Oil locks and hinges. Repair roof seams as needed.
- ◆ **Countertop and Cabinets** - Wash with mild soap and water.
- ◆ **Curtains** - Remove and clean according to care specifications.
- ◆ **Windows** - Cover windows by pulling blinds, closing shades or using a separate cover such as a sheet.
- ◆ **Holding Tank** - Drain and rinse. Close valves.

NOTE:

Add a small amount of antifreeze to waste holding tanks to keep valves and gaskets lubricated.

- ◆ **Drain Traps** - Pour RV antifreeze down all drains.
- ◆ **Refrigerator** - Clean and leave both doors propped open. Cover exterior panels and roof vents.
- ◆ If equipped with residential refrigerator drain icemaker and icemaker tray, see manufacturers manual for more detail.

- ◆ **Batteries** - Add distilled water and recharge if needed. If necessary, disconnect the cables, remove the batteries and store them in a cool dry place. Check and recharge as needed.
- ◆ **Air Conditioner** - Remove the air filters. Clean or replace.
- ◆ **Roof** - Keep clear of snow accumulation or damage may occur.
- ◆ **Interior/Exterior** - Storing under cover or indoors helps extend interior and exterior life.
- ◆ **Fuel Tank** - Diesel fuel tank should be full of fuel.

Removal from Storage

Extensive freeze damage or other serious deterioration can occur if the motorhome is not properly winterized. If the motorhome is properly and carefully prepared for storage, removal from storage will not be difficult. The following checklist pertains to items or areas that should be inspected when it is time to take the motorhome out of storage and put back into operation. If you have any questions regarding storage or winterization, consult a qualified service technician.

- ◆ Thoroughly **inspect** the outside of motorhome. Look for animal nests in the wheel wells or in other out of the way places.
- ◆ Remove all appliance flue vent covers, ceiling vent covers and air conditioning covers. Be sure the refrigerator openings are free of debris, insect nests, webs, etc.

- ◆ Open all doors and compartments. Check for animal or insect intrusion, water damage or other types of damage which may have occurred.
- ◆ Check the state of charge of the batteries. If necessary, fill LLA cells with distilled water only. Charge as necessary. **Inspect** the cable ends and terminals. They should be secure and free of corrosion.
- ◆ Check all the chassis fluid levels: engine oil, engine coolant, hydraulic fluid reservoir, transmission oil and rear axle oil.
- ◆ Start the engine, allowing it to reach operating temperature. Ensure the engine instruments indicate proper readings.
- ◆ While the engine is running, check the operation of headlights, taillights, turn signals, back-up lights, license plate light and emergency flasher. Operate the dash air conditioner. If the air conditioner does not work or the compressor makes unusual noises, have the system checked by a qualified air conditioner technician.
- ◆ Shut the engine down. Adjust or add fluids as necessary. **Inspect** around the engine and under the motorhome for fluid leaks.
- ◆ Drain, sanitize and flush the fresh water system as outlined in the *Water Systems - Section 6*. **Inspect** the sewer drain hose and connections for leaks. Replace if necessary.

- ◆ Operate all faucets and fixtures in the fresh water system. Run a sufficient amount of fresh water through all the water lines and faucets to thoroughly purge any potable antifreeze from the fresh water system.

NOTE:

Discard at least the first two trays of ice from the icemaker to ensure the ice does not contain traces of antifreeze or other contaminants.

- ◆ Open cabinet doors and drawers. **Inspect** for water leaks at joints or fittings. Repair as necessary.
- ◆ Operate all 12 Volt DC lights and accessories. If something does not work there may be a bad 12 Volt DC circuit breaker or blown fuse.
- ◆ Install new batteries in battery operated safety detectors or devices. Test the Carbon Monoxide, LP-Gas and smoke detectors for proper operation.
- ◆ Check that the monitor panel is properly functioning.
- ◆ **Inspect** the 120 Volt AC electrical system which includes the power cord, inverter/converter, all outlets and exposed wiring.

NOTE:

Prepare the generator for operation following the instructions in the Generator OEM manual.

- ◆ Start and run the generator.
- ◆ Confirm that the batteries are being charged. Operate the 120 Volt AC appliances and air conditioners. If an electrical item or appliance is not properly functioning, contact the dealer or an authorized service center to have it evaluated.
- ◆ Have a qualified technician inspect the LP-Gas system and perform an LP-Gas leak test. The leak test should also include an LP-Gas regulator adjustment (if needed). The test can also verify if the regulator is faulty and should be replaced. Have the LP-Gas tank inspected.
- ◆ Operate each LP-Gas appliance. Observe all burner/pilot flames for proper color and size.
- ◆ Inspect and clean the interior.
- ◆ Check the sealant around all roof and body seams and windows. Reseal if necessary.
- ◆ Lubricate all the exterior locks, hinges and latches with a graphite lubricant.
- ◆ Check the windshield wiper blade condition. Check the wiper/washer operation.
- ◆ Wash and wax the exterior. Check the body for scratches or other damage; touch up or repair as necessary. Flush the underside thoroughly.
- ◆ Run through the operational checks for steering, brakes, engine and transmission. Operate the motorhome slowly during these checks to allow sufficient circulation of fluids and resetting of the components.
- ◆ If desired, have the dealer or repair center double-check preparation to make necessary adjustments and/or correct defects.

THE EXECUTIVE 07

APPLIANCES — SECTION 4

APPLIANCES - INTRODUCTION	92	AQUA-HOT	106
REFRIGERATOR	92	Troubleshooting	107
Operation Specifics	92	Bay Thermostat.....	107
Control Panel	93	Care & Maintenance.....	107
Icemaker.....	94	Fuel Filter	109
Refrigerator Alarm.....	95	Aqua-Hot Overview	110
Cooling Unit Fans	95	ELECTRIC BASEBOARD HEATER (OPT)	110
Doors	95	WASHER-DRYER PREPARED	110
Storage Procedures.....	95	WASHER-DRYER (OPT)	111
Interior Light.....	95	Test Procedure	111
Service	96	Washer/Dryer Maintenance	112
Air in LP-Gas Supply Lines	96	Winterizing the Washer/Dryer	113
REFRIGERATOR - RESIDENTIAL (OPT)	96	WASHER (OPT)	113
WATER DISPENSER - HOT (OPT)	98	Test Cycle	113
MICROWAVE/CONVECTION OVEN	99	Operating Instructions	114
Setting the Clock.....	100	Cleaning the Washer	115
Care & Cleaning	100	Winterizing the Washer.....	115
AUTOMATIC APPLIANCE SELECTOR	101	DRYER (OPT)	115
COOKTOP	102	Dryer Maintenance.....	116
Care & Cleaning	103	DISHWASHER (OPT)	117
WALL THERMOSTAT	103	CENTRAL VACUUM (OPT)	118
AIR CONDITIONING - ROOF	104	Operation	118
Operations	104	Maintenance	118
Heat Pump Operation	105		
Return Air filters	105		

APPLIANCES - INTRODUCTION

This section covers operation and care of various appliances found in the motorhome: refrigerator, cooktop range, microwave, Aqua-Hot, roof air conditioner and optional appliances. These appliances operate on AC or DC current, LP-Gas or a combination of the three.

INFORMATION:

Detailed information with **CAUTION** or **WARNING** instructions for the various appliances, other than what is found in this section, can be found in the manufacturer manuals.

WARNING:

Before entering any type of refueling station, turn off all LP-Gas operated appliances. Most LP-Gas appliances used in recreational vehicles are vented to the outside. When parked close to a gasoline pump, it is possible for fuel vapors to enter this type of appliance and ignite, resulting in an explosion or fire.

WARNING:

Carbon Monoxide gas may cause nausea, fainting or death. Operating an LP-Gas appliance with inadequate ventilation or partial blockage of the flue can result in Carbon Monoxide poisoning. **DO NOT** store flammable liquids such as lighter fluid, gasoline or propane in the outside refrigerator compartment.

NOTE:

Features and options vary with floorplans.

REFRIGERATOR

Refrigerant is heated until it vaporizes. When the refrigerant cools, heat is extracted from inside the refrigerator. Gravity returns the coolant to a reservoir and the cycle is repeated. To ensure longevity and proper operation of the refrigerator, follow the specific guidelines in the refrigerator manual. With proper care and maintenance, the refrigerator should provide years of trouble-free service.

INFORMATION:

Refer to the refrigerator manual for detailed operating and maintenance instructions.

NOTE:

To reduce the possibility of food spoilage, keep the interior box temperature at or below 40° F. The refrigerator will consume more energy to maintain low temperature, especially in hot, humid climates. Lower temperature may also lead to more frost build-up.

Operation Specifics

- ◆ The refrigerator operates from LP-Gas or 120 Volts AC electric.
- ◆ DC Voltage for control pad operation must be no higher than 15.4 Volts DC or lower than 10.5 Volts DC.
- ◆ AC voltage must be no higher than 132 Volts AC or lower than 108 Volts AC.

Important: Operate refrigerator only when level. Level the refrigerator, using a torpedo or bulls eye (fence post) level. Place the levels on the bottom shelf of the refrigerator. The bubble should be at least half-way inside the circles.

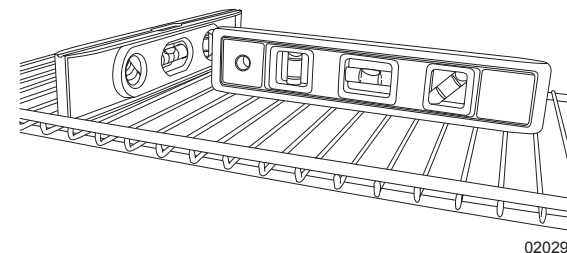

020295

CAUTION:

Operating the refrigerator off-level separates chemicals, causing them to crystallize and block the circulation action of the cooling unit. Damage is cumulative and irreversible.

WARNING:

DO NOT use the refrigerator if there is an ammonia smell inside or outside of the refrigerator, or if a yellowish substance appears inside or at the outside access compartment. This can be an indication of a refrigerant leak. Contact an authorized repair facility.

For the refrigerator to operate:

- ◆ The house batteries must be charged.
- ◆ The battery cut-off switch must be on.
- ◆ The primary LP-Gas valve must be on, the electric gas valve must be on or an AC source must be available.
- ◆ The icemaker water valve (located at the plumbing manifold in the service bay) must be open if the refrigerator is equipped with an icemaker.
- ◆ **Figure A:** The refrigerator 120 Volt AC cord(s) must be plugged in (located outside behind refrigerator access door).
- ◆ **Figure B:** If controls do not light up, check house battery charge status or see if the 12 Volt DC wires are plugged into the refrigerator's circuit board (located outside behind refrigerator access door).

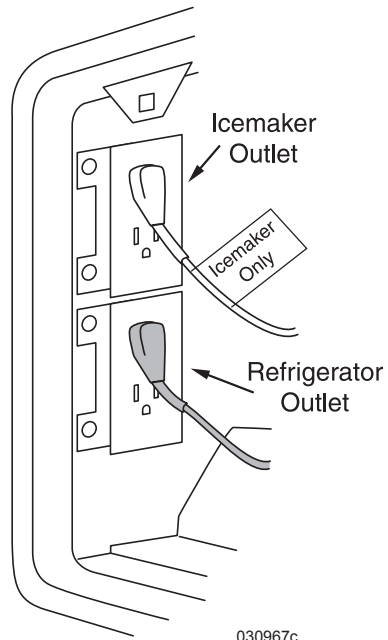
**Figure A**

The icemaker valve on the water manifold must be open for the icemaker to operate.

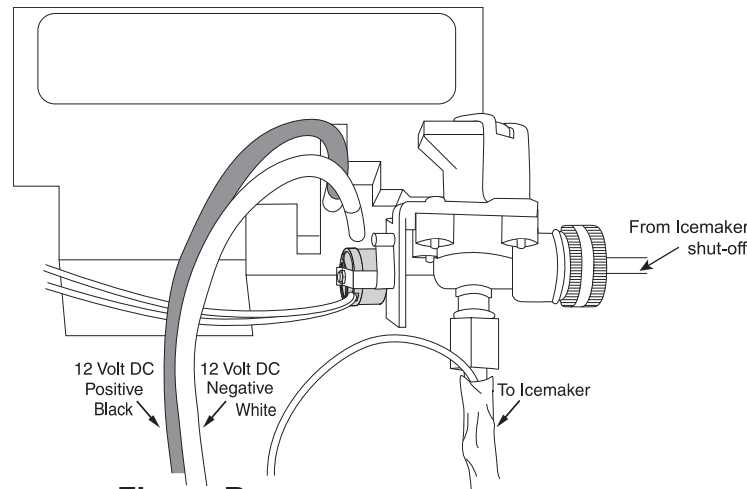
**Figure B**

Valve located on plumbing manifold in service bay

Control Panel**ON/OFF Button:**

Turns the refrigerator **ON** or **OFF**.

- ◆ Push the **ON/OFF** button to start the refrigerator in **Auto mode**.
- ◆ Push and hold the **ON/OFF** button for two seconds to shut it off.

LED Display:

This screen is used for mode, temperature and fault code display.

MODE Button:

Controls the operation mode of the refrigerator.

- ◆ Press the **MODE** button to select between Automatic **AU**, **AC** or **LP** operation.

SET TEMP Button:

Adjusts the temperature.

- ◆ To adjust, push and hold the **SET TEMP** button.
- ◆ Number “9” is the coldest setting.

Manual Mode (MAN):

When one of the two manual modes is selected:

1. **AC** = The refrigerator is operating on AC electric.
2. **LP** = The refrigerator is operating on LP-Gas.

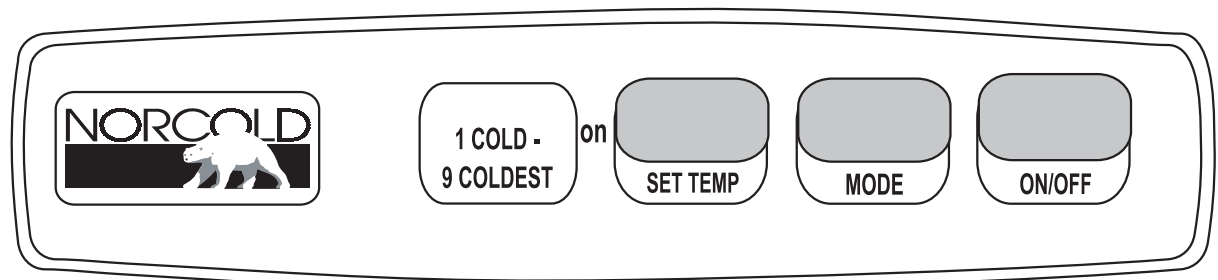

030864d

Automatic Mode (AU):

This feature selects AC over LP-Gas operation. If AC discontinues, the refrigerator will automatically switch to LP-Gas operation. An alarm will sound and a code will display if the LP-Gas igniter fails to light.

- ◆ Press the **MODE** button until **AU** displays. Release the button.
- ◆ Press and hold the **SET TEMP** button until the desired temperature displays. Release button.
- ◆ In **AUTO** mode, **AU/AC** or **AU/LP** will alternate three times when a mode has changed.

If the LP-Gas does not ignite within 30 seconds, the control changes to a different energy source or the gas safety valve closes and “**NO**” “**FL**” displays. Turn the refrigerator **OFF** then back **ON**. If the gas does not ignite after several attempts, consult an authorized service technician.

Tips:

- ◆ Cool items first, if possible, before putting them into the refrigerator.
- ◆ Keep the doors shut. Know what you want before opening the doors.
- ◆ Allow the refrigerator 24 hours of operation before actual use to help get a head start with the refrigeration process.
- ◆ A box of open baking soda will help absorb food odors.

- ◆ Ice build up can be slowed in high humidity if the end of the drain tube is submersed in drip pan. It may be necessary to add water to the drip pan to keep the tube submersed.

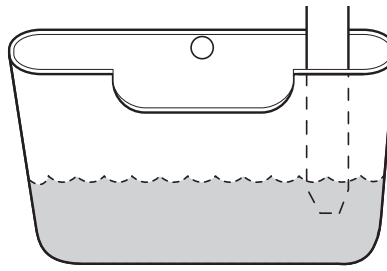

030987
Drip Pan: Located behind the outside access.

Icemaker

The icemaker requires 120 Volts AC to operate. Only after the freezer reaches freezing temperature will the icemaker function. City water or the water pump must be on and the valve for the water supply line to the icemaker must be on. The valve is located on plumbing manifold in water service bay.

- ◆ Pull the metal arm (bail) down to turn the icemaker **ON**.
- ◆ Push the arm up to turn the icemaker **OFF**.

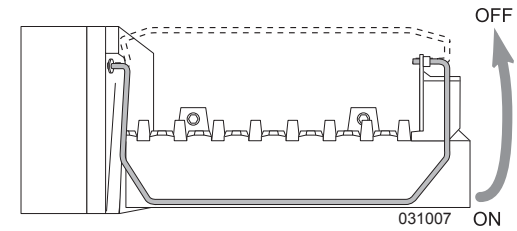
**NOTE:**

Water may spill out of the ice tray if the icemaker is in operation while the motorhome is in transit. **DO NOT** use the first one or two trays of ice following storage. Operating the icemaker without water pressure supplied to the refrigerator will risk damage to the icemaker assembly.

Water Line Heater:

A thermal disc supplies voltage to heater tape when ambient temperature is less than 38° F (+/- 4°) and shuts off at temperature greater than 48° F (+/- 5°). The water line heater is only for the line from the solenoid to the icemaker. The line from the icemaker shut-off valve to the water valve is protected with foam insulation.

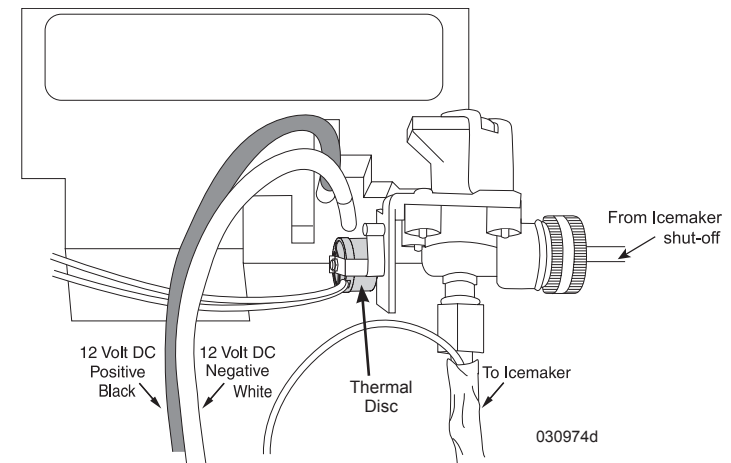

Refrigerator Alarm

The refrigerator audible alarm will sound for the following reasons:

1. DC or AC voltage is higher or lower than allowed.
2. The refrigerator fails to light on LP-Gas or fails to light after a period of operation.
3. Refrigerator is set to **Auto**, 120 Volts AC is discontinued and LP-Gas fails to light. **NO AC** will display, followed by **NO FL**, and the alarm will sound. Consult the OEM manual.
4. Door is open longer than two minutes.
5. The circuit board detects a failure. The control panel will display a code.

NOTE:

If the alarm sounds, note the code in the LED display and turn the refrigerator off to silence the alarm.

INFORMATION:

Refer to the OEM manual for the list of codes and their meanings.

Cooling Unit Fans

The cooling unit is equipped with a pair of cooling fans that pass air across the cooling unit. These fans start automatically and are audible when in operation.

Doors

The refrigerator doors use a positive latch that secures the door with a “click” to prevent the door from opening during travel. The doors use a heating element located in the flapper on the left door. The heating element activates when operating the refrigerator in any mode to help prevent moisture accumulation in high humidity conditions.

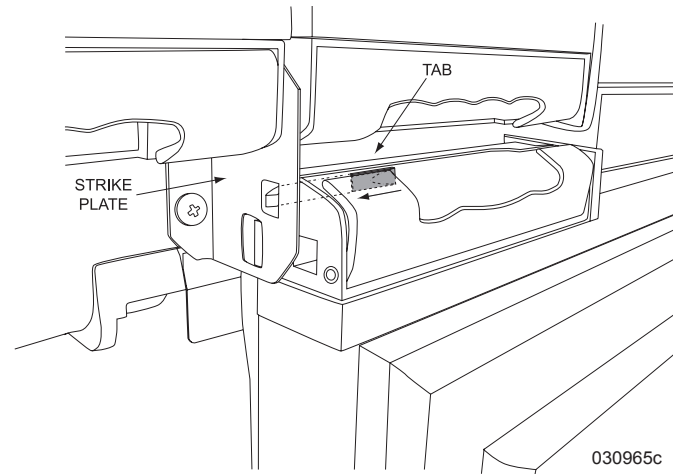

Mold and mildew may contaminate a completely sealed refrigerator in storage. The motorhome refrigerator has a storage position to lock the doors partially open and promote airflow that will help prevent mold build up. To use the refrigerator storage position:

1. Completely empty the refrigerator.
2. Disconnect power to the refrigerator.
3. Thoroughly clean the interior box using a soft cloth to remove all stains and spills.
4. Partially open the doors and slide tab into the cut-out of the striker plate.

Storage Procedures

Storage Feature:

- ◆ Turn the refrigerator **OFF** and remove all items. Leave the drip tray under the cooling fins.
- ◆ **DO NOT** use a heating gun, hair dryer or sharp objects to remove frost as these can damage the interior or cooling unit.
- ◆ Wash the interior using mild spray cleaners or a solution of liquid dish detergent and warm water. **DO NOT** use scouring pads or abrasive cleaners that can damage the interior finish.
- ◆ Rinse with a solution of baking soda and water. Dry with a clean cloth.
- ◆ Lock the doors open.

CAUTION:

DO NOT use a hot air blower to defrost. Permanent damage could result to plastic parts. **DO NOT** use a knife, ice pick or any other sharp instrument to remove ice from the freezer as they can puncture the system.

Interior Light

The interior light is located at the top of the fresh food compartment. When the door is open the light will illuminate.

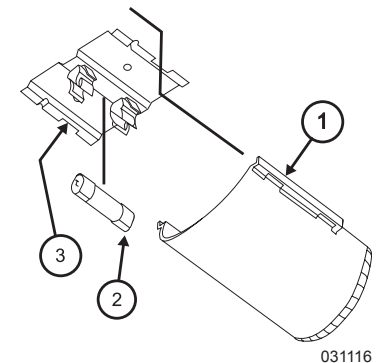

Bulb Replacement:

1. Remove the light cover by pulling it toward the front of the refrigerator.
2. Remove the light bulb from the holder.
3. Install a **GE#214-2** replacement bulb and replace the cover.

Service

The LP-Gas function of the refrigerator and LP-Gas pressure will require annual service. Over time, the BTU rating of the flame can change, affecting the refrigerator's performance. Ambient temperature, high humidity and altitude above 5,500 feet can affect performance and function. If possible, switch mode operation to AC while at a higher altitude.

Ensure the exterior refrigerator access panel is properly replaced after removal.

NOTE:

Ensure the exterior refrigerator access panel is properly replaced after removal.

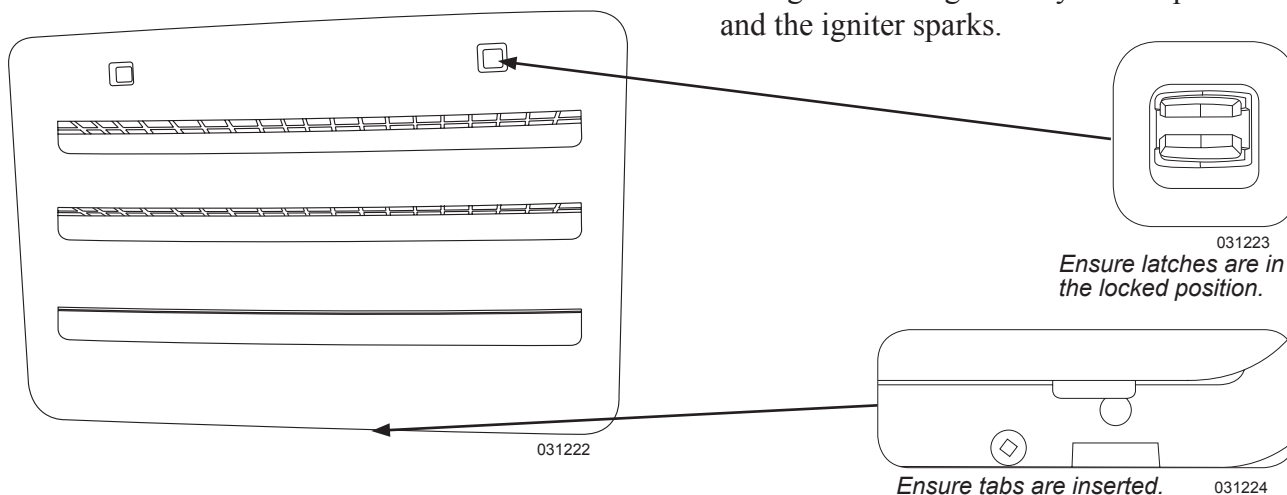
**Air in LP-Gas Supply Lines**

For safety reasons, the refrigerator will attempt to ignite on propane gas within a specified amount of time. When starting the refrigerator for the first time after storage, or after servicing the gas supply system, propane gas supply lines may contain air. Due to the air in the gas supply lines, the refrigerator may not ignite on propane gas within the specified amount of time. Follow the procedure on how to remove air from the LP-Gas supply lines.

To remove the air from the LP-Gas supply lines:

- ◆ Ensure the primary LP-Gas valve and any other necessary valves are open.
- ◆ Try lighting the cooktop burners first to quickly purge air from the main distribution line.
- ◆ Push the **ON/OFF** button to turn the refrigerator on.
- ◆ Press the **MODE** button until the refrigerator indicates LP. The refrigerator will start a 30 second trial for ignition during which the gas safety valve opens and the igniter sparks.

- ◆ If the refrigerator fails to light, indicated by **F** or **NO FL (No Flame)**, turn the refrigerator **OFF** then back **ON** and set to **LP mode**. If after the third attempt the refrigerator fails to light, stop and consult your local dealer or an authorized Norcold Service Center.

REFRIGERATOR - RESIDENTIAL (OPTIONAL)

The refrigerator operates from shore power, the generator or the inverter. Thermostat controls for the refrigerator and freezer temperature are located inside the refrigerator. The freezer door has a water dispenser and ice cube dispenser. Ice can be dispensed as crushed or cubed. An infrared sensor prevents dispenser operation with the freezer door open.

NOTE:

The refrigerator operates on 120 Volts AC, not from LP-Gas.

Refrigerator Operation from Inverter While Traveling:

Turn the inverter and refrigerator **ON**. The electrical combination of the engine alternator and the inverter will supply the power necessary to operate the refrigerator on 120 Volts AC while traveling.

INFORMATION:

See the OEM manual for temperature adjustment and other features.

Tips:

- ◆ If possible, cool items first before putting them into the refrigerator.
- ◆ Keep the doors shut. Plan ahead what is needed before opening the doors.
- ◆ Allow the refrigerator 24 hours of operation before actual use to help it get a head start with the refrigeration process.
- ◆ A box of open baking soda will help absorb food odors.
- ◆ When dry camping use the inverter to supply AC power to the refrigerator. It is recommended to use the Automatic Generator Start system. The amount of time the refrigerator will run from the inverter will vary depending on the state of charge of the house batteries.

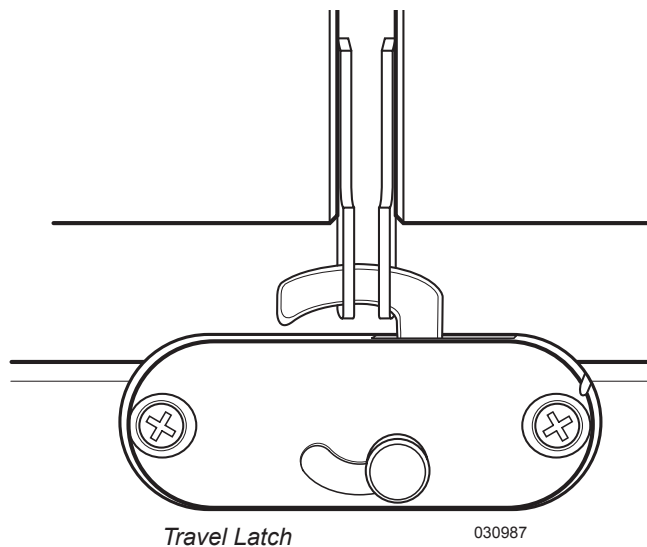
**NOTE:**

Ensure that the travel latch is engaged prior to travel.

NOTE:

It is advisable to acquire a refrigerator thermometer. Keep the interior box temperature at or below 40° F to reduce the possibility of food spoilage.

NOTE:

When dry camping, enable the Automatic Generator Start feature to avoid dead house batteries and the possibility of food spoilage.

Icemaker:

The icemaker operates on 120 Volts AC and will function only after the freezer reaches freezing temperature. When the freezer door is open, the infrared signal is interrupted and shuts off the ice dispenser.

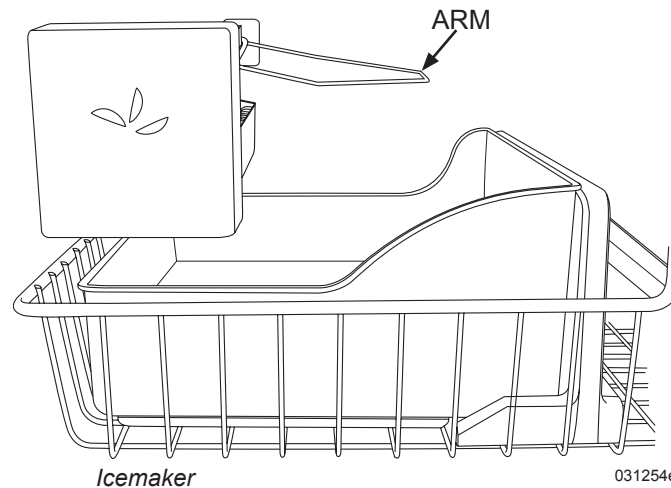
**To Operate the Icemaker:**

- ◆ Hook to city water or turn on the water pump. The valve for the water supply line to the icemaker must be open. The valve is located at the plumbing manifold in the service bay.
- ◆ Push down the icemaker arm to start the icemaker.
- ◆ Manually turn the icemaker off by lifting up the icemaker arm to prevent water from spilling out of the ice tray while the motorhome is in transit.

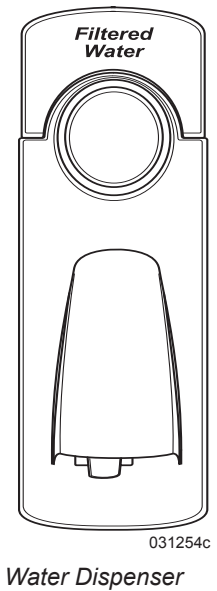
**NOTE:**

DO NOT use the ice made within the first 12 hours after the refrigerator is removed from storage. Ice cubes may contain contaminants. DO NOT operate the icemaker without water pressure supplied to the refrigerator as damage to the assembly may occur.

Water Dispenser:

A water dispenser is located on the left side of the refrigerator interior to dispense cold filtered water. Hold a container under spout and press the dispenser button.

Water Filters:

The refrigerator uses a built-in water filter for the icemaker and cold water dispenser.

Initial Installation:

- ◆ Open the filter housing located in the upper right corner of the refrigerator interior.
- ◆ Turn blue bypass cap counterclockwise to remove. Save for later use.
- ◆ Remove seal from filter and insert into filter head. Gently turn clockwise until the filter stops. **DO NOT** force.
- ◆ Snap filter housing together.

NOTE:

It may be necessary to run water through the refrigerator dispenser for two minutes to remove air from system lines.

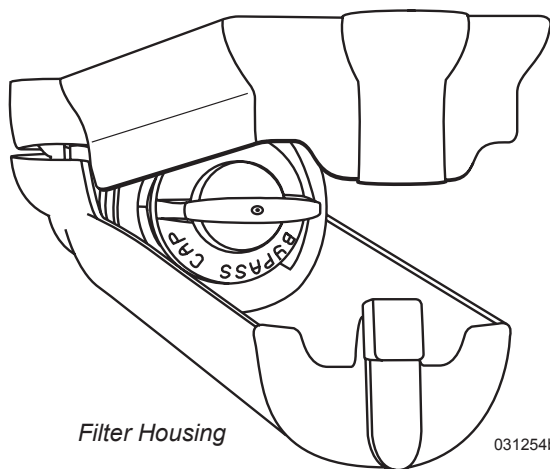
**Filter Replacement:**

The filter should be replaced every twelve months. The filter may need to be changed more often depending on use and water quality. See the OEM manual for replacement filters.

CAUTION:

Air trapped in system may cause water and cartridge to eject. Always dispense water for at least two minutes before removing the filter for any reason. Use caution when removing.

WATER DISPENSER - HOT (OPTIONAL)

A compact tank, mounted under the sink, uses 120 Volt AC to electrically heat water to 190° F (88° C). A thermostat is installed to maintain the water temperature. The tank is vented to prevent tank pressurization.

WARNING:

To minimize the possibility of fire DO NOT store flammable items such as rags, paper or aerosol cans near the mounted tank. DO NOT store or use gasoline or other flammable vapors and liquids in the vicinity of this unit.

WARNING:

DO NOT remove or alter the thermal safety fuse. If the thermal fuse is open, contact an authorized service center. To prevent electrical shock turn the power switch OFF and disconnect the power cord before removing the access cover to adjust or service the thermostat.

Operation:

When the Insta Hot is plugged into a 120 Volt AC outlet, it takes approximately 10 to 15 minutes for the water to reach 190° F (88° C). **Use caution: steam or hot water may spurt from the faucet without turning it on.** After 10 to 15 minutes, turn the faucet on for about 20 seconds to release steam that may have built up in the hot water tank. Allow the water in the tank to reheat. Repeat this step one or two times. When a steady stream is dispensed, the hot water is ready for use. To shut off the system, turn the switch to the **OFF** position.

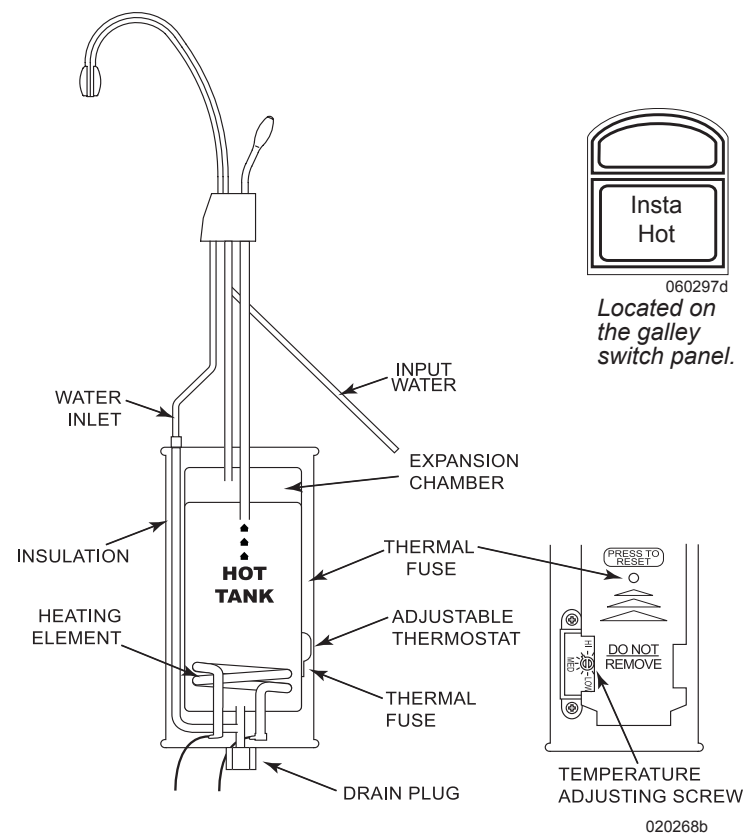

Temperature Adjustment:

If the steam continues or the water boils, adjust the temperature as follows:

- ◆ Unplug the power cord.
- ◆ Remove the screw and access cover.
- ◆ Insert a screwdriver in the slot of the thermostat adjusting screw. Turn the screw clockwise ½ notch to increase the water temperature; counterclockwise ½ notch to decrease the water temperature.
- ◆ Reinstall the access cover, reconnect the electric power and turn on the galley switch.
- ◆ Draw three or four cups of water and allow unit to reheat.
- ◆ Repeat the procedure until desired temperature is reached.

CAUTION:

DO NOT allow the water to boil.

Thermal Cut-Out:

Should the Insta-Hot stop or fail to heat water, it may be a result of the thermal cut-out tripping. Open the access panel, press the Reset button.

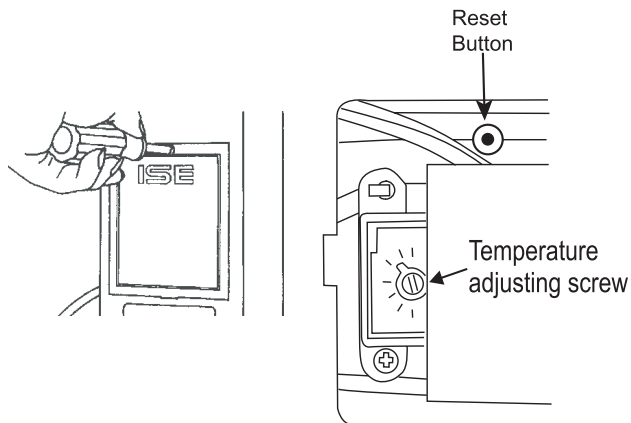

040368c

Cleaning Hot Water Dispenser:

Use only mild cleaners to clean the dispenser spout and plastic components. Use of cleaning agents containing acids, alkalies and organic solvents will result in the deterioration of plastic components.

Draining the Insta-Hot Tank:

Drain the Insta-Hot tank before storage or if interior temperature drops below freezing.

To Drain:

- ◆ Place a large pan or dish beneath the tank under the sink in the galley to catch leaks. Note that the Insta-Hot tank holds approximately ¾ gallon.
- ◆ Remove the drain plug.

WARNING:

Use care when operating this unit. DO NOT allow children to operate this unit. The tank is a non-pressure tank. DO NOT modify this system. DO NOT close the vent tube or connect other types of faucets or valves to the tank. Use only the faucet supplied. DO NOT allow the water to boil. The water and steam dispensed can instantly cause scalds or burns.

MICROWAVE/CONVECTION OVEN

The microwave/convection oven operates from 120 Volt AC supplied by shore power, the generator or inverter.

Operation Tips:

- ◆ Ensure cookware being used is microwave safe. Gold paint or glaze may contain a trace amount of gold which is electrically conductive and not compatible for microwave. Hand painted china commonly contains traces of metal.
- ◆ The glass tray and roller guide must always be in place during cooking.
- ◆ Ensure the door is firmly closed before use.
- ◆ If the control pad is not lit, plug another electrical appliance into the same outlet to verify 120 Volt AC power is present. If the test item works, contact an appliance repair facility to have the microwave/convection oven checked.
- ◆ Steam accumulating inside or around the outside of the oven door may occur when the microwave/convection oven is operated under high humidity conditions and in no way indicates a malfunction of the unit. Wipe away steam using a soft cloth.

Microwave/Convection Oven Facts:

One of the most useful documents for the microwave/convection oven is the operations manual, located in the owner's information file box. Read it carefully and keep it for reference.

A properly functioning microwave/convection oven presents no hazard with ordinary use. Safety features should be kept in good condition. Never attempt to bypass safety interlocks or allow debris or residue to accumulate on the door or oven face. If the oven is damaged, discontinue use.

Oven adjustments or repairs should be made by qualified service personnel. Check the microwave/convection oven owner's manual for maintenance tips and other information. Remember to register the microwave/convection oven with the manufacturer.

CAUTION:

The ventilation fan cannot be manually turned off if it has automatically started from a heated cooktop. Turn off the microwave AC breaker to prevent the flames from spreading into the microwave.

NOTE:

When dry camping, minimize using the inverter to operate the microwave/convection oven due to the high rate of battery consumption.

NOTE:

The microwave/convection oven is for food preparation only. **DO NOT** use the microwave/convection oven to dry clothes, newspapers, shoes or other items.

CAUTION:

Long-term use of the inverter to operate the microwave while in transit will damage the alternator. Use the generator to operate the microwave while in transit.

Setting the Clock

To Set the Clock:

- ◆ Press the **STOP/CLEAR** pad.
- ◆ Press the **CLOCK** pad.
- ◆ Enter correct time in sequence using the number pads.
- ◆ Press the **CLOCK** pad to begin time.

NOTE:

The clock is a 12 hour clock only.

Care & Cleaning

The exterior of the microwave/convection oven is plastic and metal. The interior is metal. **DO NOT** clean with scouring pads, harsh or abrasive cleaners, chemical cleaners or petroleum based thinners that can damage the finish. Use mild soap and water with a damp cloth or paper towel to remove stains or spills. When cleaning the touch pad, open the door to prevent accidental operation. Use mild soap and water with a soft cloth. Avoid using excess amounts of water on the touch pad. The turntable plate and oven racks are dishwasher safe.

Charcoal Filter:

Depending on use, the charcoal filter should be replaced every 6 to 12 months. Use the following procedure to remove the louvers to replace the charcoal filter and oven light:

1. Remove power to the microwave/convection oven.
2. Remove the screws (A) securing the louver.

3. Insert a flat edge screwdriver over each tab pressing downward and move the louver away from the microwave.
4. Remove and replace the charcoal filter. Ensure the filter is positioned on the supporting tabs.
5. Replace louver and mounting screws.

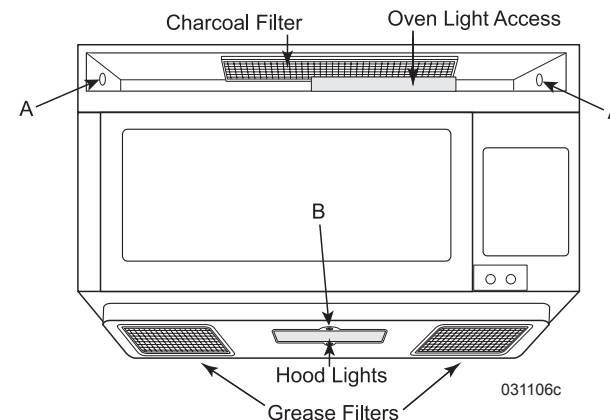

Oven Light:

1. Remove the louver as previously indicated.
2. Slide the metal light cover forward and lift upwards.
3. Remove the light bulb and replace only with an equivalent watt bulb. **DO NOT EXCEED 30 WATTS.**
4. Replace light cover, louver and mounting screws.

Hood Light:

1. Remove power to the microwave/convection oven.
2. Remove the screw **(B)** securing the light cover.
3. Remove the light bulb and replace only with an equivalent watt bulb. **DO NOT EXCEED 30 WATTS.**
4. Close the cover and re-secure with screw.

CAUTION:

Light cover may be hot. DO NOT touch glass with lamp ON. Never use the light for prolonged periods, such as a night light.

Grease Filters:

Operating the microwave/convection oven without the grease filters in place can damage the unit. Grease filters should be cleaned at least once a month. To remove the filters, use the pull-tab to slide the filter to the end of the opening and tip down. Soak the filters in the sink or in a dishpan filled with hot water and detergent.

- ◆ **DO NOT** use ammonia or other alkali-based products that may darken the filter material.
- ◆ Agitate the filter. Use a scrub brush to remove caked on grease.
- ◆ Rinse the filter thoroughly and shake dry. Place the filter back into the opening, tip upward and slide filter to the end of the opening. Lock in place. Be careful not to kink or warp the filter upon installation.

Cleaning Tips for the Microwave:

- ◆ Turn the oven **OFF** before cleaning.
- ◆ Cover food while cooking to keep food spattering to a minimum.
- ◆ Clean up all spills or spatters before they dry. Wipe up food spatters or spilled liquids with a damp cloth. Mild detergent may be used for stubborn spills. **DO NOT** use harsh detergent or abrasive cleaner.
- ◆ It is occasionally necessary to remove the glass tray for cleaning. Wash the tray in warm, sudsy water or in a dishwasher.
- ◆ The roller guide and oven cavity floor should be regularly cleaned to avoid excessive noise. Wipe the bottom surface of the oven with mild detergent water or window cleaner and then dry. The roller guide may be washed in mild sudsy water.
- ◆ Food odors may linger inside oven. To help eliminate odors, combine the juice and the peel from one lemon, several whole cloves and 8 oz. of water into a two cup bowl. Place in oven on high power; bring to a boil for several minutes. Let cool in the oven for several minutes.
- ◆ Clean the outside oven surface with soap and water. Wipe away any residue using a damp cloth. Dry with a soft cloth. To prevent damage to the operating parts inside the oven, do not allow water to seep into the ventilation openings.
- ◆ If the control panel becomes wet, clean with a soft, dry cloth. **DO NOT** use harsh detergents or abrasive when cleaning the control panel.

AUTOMATIC APPLIANCE SELECTOR

The Automatic Appliance Selector limits the possibility of shore power overload by allowing only the priority appliance to operate. The system uses automatic switching relays to control AC power to the appliances hooked to Automatic Appliance Selector.

The appliances are listed in the order in which they are controlled by the Automatic Appliance Selector. Only one component can be in use at a time.

Standard:

1. Washer-Dryer
2. Bedroom Roof Air Conditioner

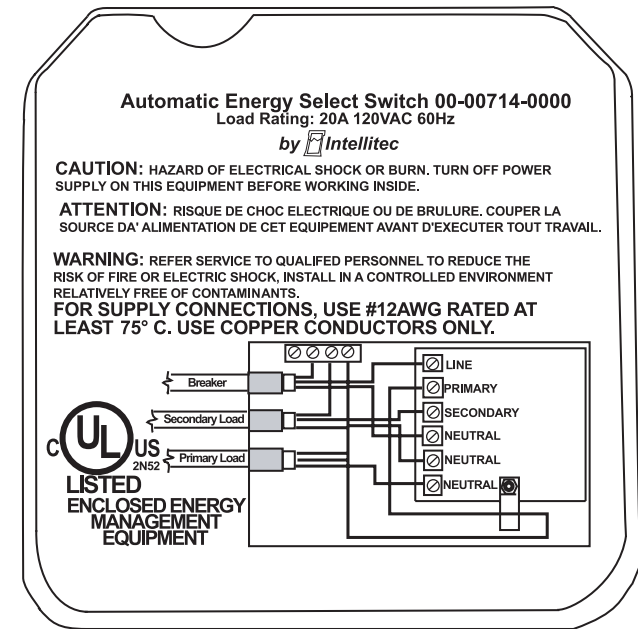

Typically located curbside in bedroom closet.

031108

COOKTOP

The cooktop uses an electric ignition system that requires 120 Volts AC from shore power, generator or inverter to operate. The cooktop should be used for cooking purposes only, not as a heating source. When the burner valve is open, the fuel source flows through the valve into the mixture tube. The fuel passes by a hole or venturi in the mixture tube, which draws air in with the fuel for a proper fuel/air ratio. The flame should have a blue appearance with a lighter blue defined flame at the burner head. A yellow flame or yellow flame tips indicate a rich fuel mixture, which can leave a black color or carbon on the bottom of the cookware.

Cooktop operation requirements:

- ◆ The batteries are charged.
- ◆ The primary LP-Gas valve on the LP tank is open.
- ◆ The LP-Gas valve in the cabinet under the cooktop (located next to the regulator) must be open.

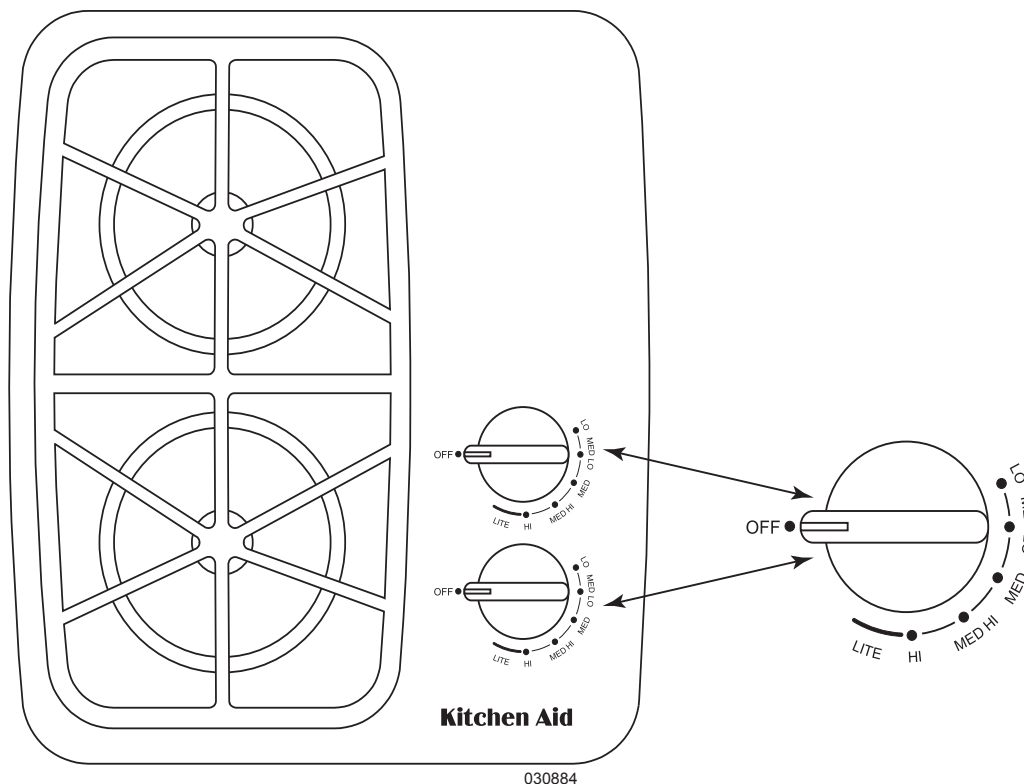

Using the Cooktop:

1. Place the cookware on the burner grate over the desired surface burner.
2. Open the burner valve by applying a downward pressure on the knob and rotating counterclockwise from the OFF position to LITE.
3. When the burner lights, rotate knob to the desired flame setting. In the event of a power outage or igniter failure, the cooktop can be manually lit.

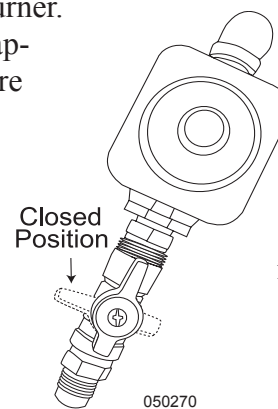

LP-Gas Valve must be open. Located under cooktop next to regulator.

Surface Burners:

Surface burners have independent heat ratings of 6,000 and 12,500 BTUs. The lower BTU burner (located next to the control knobs) can be used for smaller cookware. The higher BTU burner should be used for larger cookware. The flames at the surface burners should have an even appearance at the burner base. Uneven flames may indicate a need to clean the burners.

Control Knobs:

- ◆ Press down knob and rotate to **LITE** to activate electric spark to light the burner.
- ◆ **HI** - Used to start the cooking process and bring liquids to a boil quickly.
- ◆ **MED HI** - Used to hold a boil in liquids.
- ◆ **MED** - Used for gravy and large quantities of vegetables.
- ◆ **MED LO** - Used to keep food cooking at a reduced heat after starting from higher settings.
- ◆ **LO** - Used to keep food warm or simmer.

WARNING:

DO NOT leave burners unattended during cooking. DO NOT leave burner valve(s) open while burner(s) are not lit. LP-Gas is heavier than air and will settle on the floor and “hide” in corners. If you smell gas, extinguish all open flames. Open all windows and doors. DO NOT touch any electrical switches. They may cause a spark that can ignite. Evacuate the motorhome and shut off the primary LP-Gas valve. Liquid propane is highly volatile, highly explosive and extremely dangerous. Explosion, fire, property damage, injury or death can result. Contact a qualified service center to have the problem correctly diagnosed and repaired before resuming operation.

Cooktop Tips:

- A yellow flame is an indicator of incorrect fuel/air ratio. Lowered BTU output and carbon build up can occur.
- When cooking at an altitude above 5,000 feet, the flame may change appearance and the flame BTU output will be lowered. Allow extra cooking time.
- **DO NOT** allow the tips of the flame to extend beyond pan or pot edge. When this occurs, heat is wasted and the possibility of injury increases.
- Cooking time can be reduced if the least amount of liquid is used. The choice of cookware selected can make a big difference.
- Additional information can be located in the “Cooktop Use & Care Guide” located in the Information File Box.

Care & Cleaning

Regularly wipe down the cooktop with a soft cloth and a warm detergent solution to keep it clean. **DO NOT** clean the cooktop with abrasive or harsh cleaners such as steel wool, bleach, ammonia or oven cleaner.

Use a dry paper towel or cloth to wipe up spatters or spills when the cooktop surface is still slightly warm. To avoid accidental burns, **do not** clean the cooktop when it is hot to touch. **DO NOT** allow food to bake on. Clean the surface burner grate and caps using the same guidelines as the cooktop surface.

Porcelain Enamel:

Sharp blows, radical surface temperature changes, etc., will cause enamel to chip or crack. Some foods, such as vinegar, lemon juice, tomatoes and milk, contain acids that can dull the finish of the enamel. To avoid dulling the finish, wipe up the spill before it is baked on. Steel wool and coarse, gritty cleanser will scratch or mar the surface. Use gentle kitchen cleanser powder or grease cleaner. For further information on care and maintenance of the porcelain, call *Hopes Cultured Marble Polish* at 800-325-4026.

WALL THERMOSTAT

Comfort Controls to operate the HVAC (Heating, Ventilation and Air Conditioning systems) are located in the living room and in the bedroom.

The living room Comfort Control operates the front roof air conditioner functions and the optional Aqua-Hot living room heat exchangers. The bedroom Comfort Control operates the rear roof air conditioner, mid-roof air conditioner (if equipped) and Aqua-Hot bathroom and bedroom heat exchangers. The Comfort Controls use a liquid crystal display to show the current mode status.

The HVAC system provides five different functions: **Off, Fan, Cool, Heat Pump and Furnace** that are selected by pressing the **Mode** button.

Fan controls blower speed of the roof air conditioner. Two speeds are available - low and high. Selecting fan speed **Auto** adjusts the fan speed automatically, based on temperature set point and actual temperature in a selected zone.

The motorhome is divided into three operating zones: front, middle and rear. The selected Zone will flash. Control individual zone temperatures using the **UP** or **DOWN** buttons.

Living Room = Zone One

Hallway/Bathroom = Zone Two

Bedroom = Zone Three

NOTE:

The bedroom (Zone Three) will display as Zone One at the Bedroom Comfort Control.

NOTE:

The Comfort Control must be ON to operate any HVAC function. Do not select conflicting modes of operation. One zone cannot be on Cool while another zone is set to Furnace.

NOTE:

The motorhome will not heat or cool faster by selecting a very high or very low temperature setting.

NOTE:

Only one of the following can be used at a time: bedroom A/C or washer-dryer. This is due to the automatic appliance selector limiting the use of appliances according to priority, to prevent electrical overload.

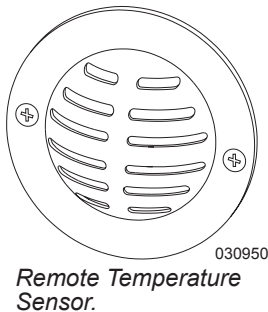
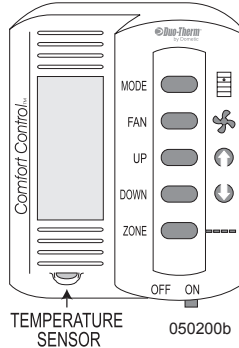

AIR CONDITIONING - ROOF

The roof air conditioners operate from 120 Volts AC supplied by shore power or the generator. The wall thermostat requires 12 Volt DC to operate.

NOTE:

The air conditioning system freezes moisture in the air. It is recommended to set the blower fan speed to high when operating in high humidity.

NOTE:

There are ambient air temperature limitations in Heat Pump mode. The roof air conditioner will not operate in Heat Pump mode with ambient temperatures of 30° F and below.

Operations

The roof air conditioner will operate only when the following needs are met:

- ◆ 120 Volts AC, from either shore power or the generator, is supplied.
- ◆ The interior house power is ON and the house batteries are charged.

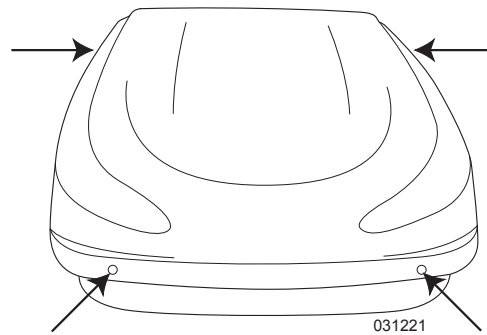

Ensure the A/C cover screws (location as illustrated by arrows) are tight when the roof is accessed.

Fan Operation:

Circulates interior air by using the roof air conditioner blower. The fan speed controls the roof air conditioner blower speed in the following modes: **Fan**, **Cool** or **Heat Pump**.

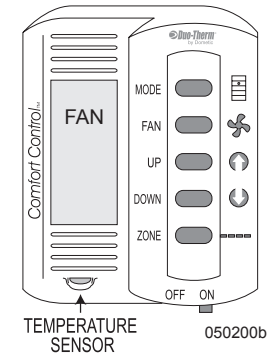

- ◆ Press the **MODE** button repeatedly until **Fan** is displayed.
- ◆ Press the **FAN** button to select the desired fan speed.

Air Conditioner Operation:

The living room comfort control operates the front roof air conditioner functions.

- ◆ Press the **MODE** button repeatedly until **Cool** is displayed.
- ◆ Set desired fan speed by pressing the **FAN** button.
- ◆ Set desired cooling temperature by pressing the **UP** or **DOWN** buttons.

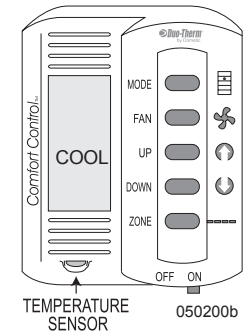

The Bedroom comfort control will operate rear roof air conditioner functions and (if equipped) the center roof air conditioner.

- ◆ Press the **MODE** button repeatedly until **Cool** is displayed.
- ◆ Press the **ZONE** button to alternate between Zone One and Zone Two. Zone One controls the bedroom roof air conditioner and Zone Two controls the center roof air conditioner.
- ◆ Set desired fan speed by pressing the **FAN** button.
- ◆ Press the **UP** or **DOWN** buttons to set desired cooling temperature.

NOTE:

The compressor will engage approximately two minutes after blower motor activation to prevent accidental compressor operation against high pressure.

Heat Pump Operation

Heat Pump mode offers heat by using the air conditioner as a heat source. The air conditioning principle is reversed, supplying heated air to the ceiling registers instead of refrigerated air. There are ambient temperature limitations in Heat Pump mode.

NOTE:

The roof air conditioner will not operate in Heat Pump mode with ambient temperatures at or below 30° F.

Aux Heat Mode:

If the Heat Pump mode is selected at or below 30° F, or if operating in Heat Pump mode and temperature drops to 30° F, the air conditioner will stop Heat Pump operation and Aux Heat will be displayed. The Aqua-Hot will be selected as the auxiliary heat source and will begin operation. The Aqua-Hot will remain the primary heat source until ambient temperature rises above 42° F.

When ambient temperature is between 30 and 42° F, a defrost cycle is initiated approximately every 40 minutes of compressor operation. The blower motor will stop for five minutes and Defrost will be displayed. After the defrost cycle the heat pump operation will resume.

NOTE:

The Aqua-Hot needs to be on for the Aux Heat to function. Turn on the Aqua-Hot diesel burner or electric element. The exchanger blowers automatically begin operation in the Auxiliary Heat mode.

Heat Pump Operation:

- ◆ Turn **ON** the interior house power.
- ◆ Slide the **ON/OFF** switch to the **ON** position.
- ◆ Press the **MODE** button repeatedly until **Heat Pump** is displayed.

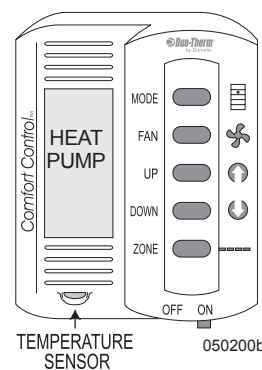

- ◆ Set desired fan speed by pressing the **FAN** button.
- ◆ Press the **UP** or **DOWN** buttons to set desired heating temperature.

Return Air filters

Frequently clean the return air filters located inside the A/C behind the intake vent covers. Access the living room filter by lowering the decorative ceiling panel using a ratchet and a 7/16" socket with an extension. The panel is secured with hinges on the curbside and bolts on the roadside. The living room panel is heavy. Remove the two end bolts first. Remove the center bolt while holding panel in place and gently lower. The living room filter is secured in place with screws. Operating the air conditioner without the return air filters in place may plug the evaporator core with dirt and substantially affect the performance of the air conditioner.

NOTE:

To prevent scratching the mirrored surface when accessing filters, place a protective barrier, such as a cotton towel, between the mirrored surface and work area of any tools.

To Clean the Return Air Filters:

- ◆ Wash filters in warm soapy water. **DO NOT** use solvents.
- ◆ Rinse filters thoroughly with fresh water. Allow them to dry.
- ◆ Install filters and secure intake vent covers.

AQUA-HOT

The Aqua-Hot appliance is a water heater and furnace. A 50,000 BTU diesel fired burner and a 1650 Watt AC element work to heat a 50/50 solution of Propylene Glycol antifreeze and water to approximately 200° F. The heated antifreeze solution circulates through heat exchangers located within the motorhome to provide interior heat. Potable water is heated by the Aqua-Hot for domestic use. The Aqua-Hot can also preheat the engine, making it easier to start on cold mornings.

NOTE:

The Aqua-Hot antifreeze is propylene glycol based boiler antifreeze. **DO NOT** mix antifreeze types.

NOTE:

The Aqua-Hot must be turned **ON** before using any heat feature.
Diesel Burner:

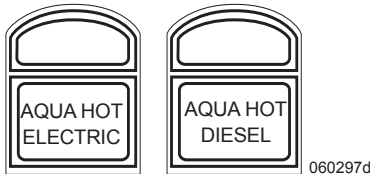

060297d

The Aqua-Hot will consume approximately ½ gallon of diesel fuel for each hour of continuous burner operation (about one or two gallons a day). The diesel burner is rated at 12 Volt DC/65 watts. Circulating pumps are rated at 12 Volt DC/12 Watts each. The Aqua-Hot has a fast recovery rate when operating on diesel. To heat the Aqua-Hot with the diesel burner, turn the Diesel switch to the **ON** position. The switch will illuminate when the Aqua-Hot is **ON**. The burner will have to operate for 20 to 30 minutes before maximum heat is available for interior heating or hot water.

WARNING:

DO NOT operate the diesel burner if the motorhome is located inside the building. Carbon Monoxide can accumulate and cause asphyxiation.

Electric Heat Element:

The electric element works well when plugged into 50 Amp service. When plugging into less than 50 Amp service, exercise care not to overload the electric service provided. The rate of recovery of the electric element is slower than the diesel burner. Allow two to three hours for the Aqua-Hot to reach operating temperature when operating from the electric element.

Interior Heat Exchangers:

The heat exchangers are small radiators with 12 Volt DC blower motors. Current consumption is approximately ½ Amp per large heat exchanger. The small heat exchanger used in the private bath and the holding tank bay is ¼ Amp. Press the blower speed switch to change the galley fan speed.



060297d
Galley Blower Switch

Engine Preheat:

The Aqua-Hot system has an engine preheat feature to aid engine starting in cold weather. Inside the Aqua-Hot is an engine coolant loop and pump that will circulate heated coolant through the engine.

To Use Engine Preheat:

- ◆ Turn **ON** the Aqua-Hot Diesel switch at the galley and allow the system to warm up.
- ◆ Turn the Aqua-Hot Engine Preheat **ON** using the switch at the dash to activate the engine pump inside the Aqua-Hot. The time required to preheat the engine varies with ambient temperature. Allow two or three hours of engine pre-heat time.

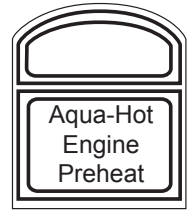

060297d

Engine Heat Exchange System:

When traveling, the water pump on the engine circulates heated engine coolant through the Aqua-Hot. Through convection, heat transfers to the Aqua-Hot coolant, providing hot water and interior heating. Use the Comfort Control to operate the heat exchangers.

To Heat the Interior While Traveling:

- ◆ Turn **ON** the interior house power.
- ◆ Set the Comfort Controls to Furnace.
- ◆ Select the desired Zone and Temperature.

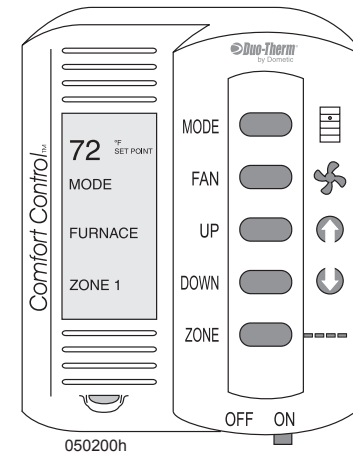

050200h

Troubleshooting

An electronic display panel (Electronic Controller) is located next to the Aqua-Hot in the curbside bay. The display panel has LED fault indicators that are used to diagnose a problem with the Aqua-Hot. If a heating source is selected (diesel or electric) and the Aqua-Hot does not appear to be working, check to see if any LED fault indicators are lit on the electronic display panel. A fault lamp may be overlooked due to viewing angle.

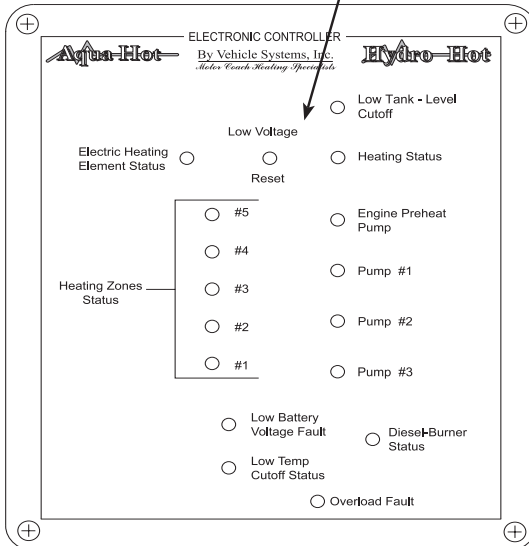
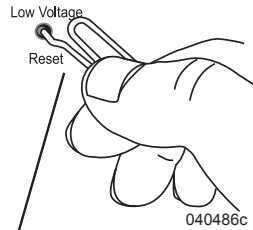

Electronic Controller located in Aqua-Hot bay.

040486b

- ◆ **Low Tank Level Cutoff:** Heating function has shutdown due to low level of coolant in the Aqua-Hot. Check coolant level.

- ◆ **Electric Heating Element Status:** Green indicator means the Aqua-Hot is being heated by 120 Volts AC.
- ◆
- ◆ **Low Voltage Reset:** The Low Battery Voltage Fault LED will illuminate. Reset the Controller by cycling the Diesel burner switch or inserting a paperclip into the hole. Press the reset button.
- ◆ **Heating Status:** The Aqua-Hot is being heated by Diesel or the 120 Volt AC electric element.
- ◆ **Heating Zones Status:** A thermostat is calling for heat in a zone. Normal LED is green. Red LED means a short has occurred in that zone.
- ◆ **Pump Status:** When a pump is operating, LED is green. A red LED indicates a short in the pump.
- ◆ **Low Battery Voltage Fault:** Red LED indicates that battery voltage is low. Hook to shore power or start the generator. The Aqua-Hot will not function until the Electronic Controller is reset by cycling the Diesel Burner switch off then back to on, or by inserting a paperclip or similar tool into the Low Voltage Reset hole. Press the Reset button.

Bay Thermostat

During cold weather, a thermostat in the storage compartment turns on the exchanger in the storage bay to prevent freezing. The thermostat turns on at 45° F +/- 10°. Ensure the Aqua-Hot is **ON** when heating the bay.

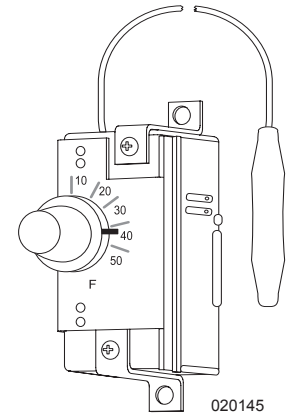

Bay Thermostat

NOTE:

Turn the Aqua-Hot ON when heating the bay.

Care & Maintenance

Heat Exchanger:

Exchangers can be affected by pet hair and debris causing performance to suffer. The Aqua-Hot exchangers require a minimum semi-annual cleaning of the heating fins, blower fans and register box. It is recommended that the surrounding area outside of the exchanger be cleaned. A vacuum cleaner works well to complete this process.

Cleaning the register:

Gain access to registers. They may be under sofas, behind cabinets, or under false floors, depending upon the floorplan. Access is limited. Be cautious not to puncture coolant lines or register core. Gently remove retaining screws. Set fans to the side. Vacuum debris or hair from inside of register paying careful attention not to bend or disfigure fins on register core. Vacuum fans then wipe clean with a soft cloth or paper towel. Reinstall fans and registers. Clean wood or metal vents in front of heat register with a soft cloth or by vacuuming.

Antifreeze:

The antifreeze is a special boiler type propylene glycol base. The antifreeze has low silicate content with corrosion inhibitors and heat transfer compounds. This type of antifreeze provides freeze protection and excellent heat transfer for operating efficiency. The antifreeze is mixed to a 50/50 ratio with de-ionized water (water purified by reverse osmosis). **DO NOT** mix antifreeze types as this can cause scaling and possible component failure. The antifreeze can be purchased directly from *Vehicle Systems Inc.*

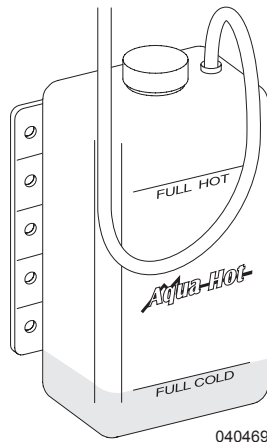

Located in the curbside fuel tank bay.

CAUTION:

Use only a non-toxic propylene glycol based antifreeze recommended for boiler applications. This antifreeze is affirmed GRAS (Generally Recognized as Safe by the EPA). Contact Vehicle Systems Inc. at 1-800-685-4298 to purchase the antifreeze.

Reservoir:

The coolant reservoir is located in the curbside fuel tank compartment. Check the reservoir coolant level monthly. Inspect the coolant level when the diesel burner has just shut off. The coolant level should be at the Full Hot level. Adding coolant to the reservoir when the Aqua-Hot is not at operating temperature may result in overflow when the Aqua-Hot attains normal operating temperature.

Disinfecting:

The tubing inside the Aqua-Hot is rated for fresh water and winterizing solutions. The potable water system can be periodically disinfected by flushing a solution through the Aqua-Hot. This solution must be thoroughly rinsed. Failure to thoroughly rinse the system with fresh water may result in damage to the Aqua-Hot.

CAUTION:

If not properly and thoroughly rinsed, bleach or other concentrated chlorine bearing chemicals can cause failure to the tubing inside the Aqua-Hot domestic water loop.

Annual Tune Up:

It is important to perform an annual Aqua-Hot tune up consisting of a fuel nozzle and fuel filter replacement and a thorough cleaning of the combustion chamber. A tune up will allow service personnel to inspect for additional wear of other components. Signs that the Aqua-Hot may need servicing are continuous white exhaust smoke or poor ignition start up. When in operation, the Aqua-Hot should have a smooth, high-pitched whine. Loud growls or other abnormal noise indicates service or repair is required.

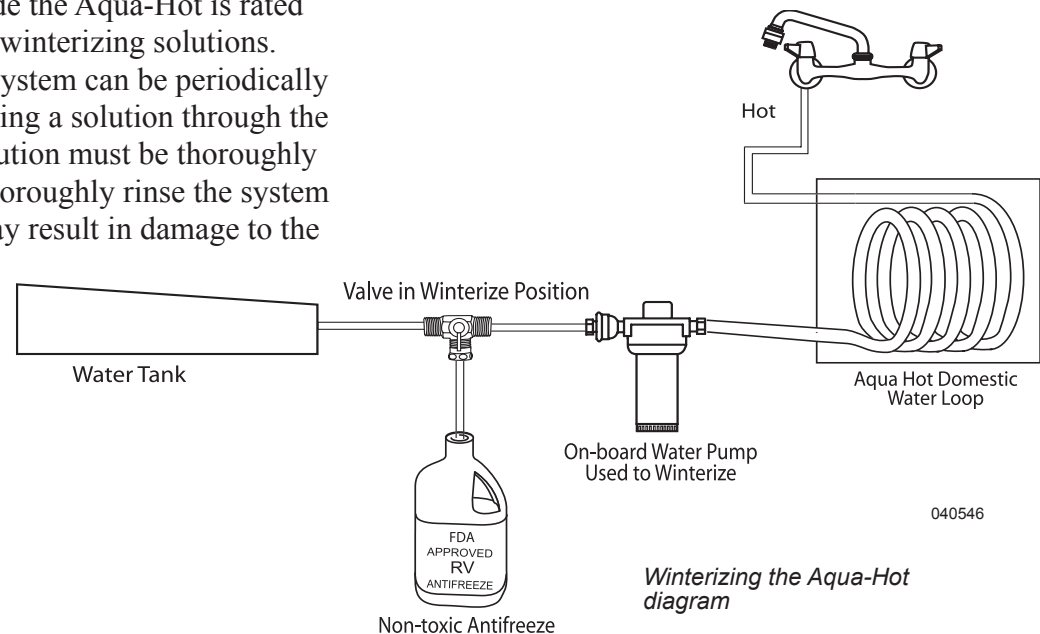

CAUTION:

Disconnect all power supplies before cleaning or servicing.

Winterize the Aqua-Hot:

The Aqua-Hot can remain on during the winter months or it must be winterized with FDA approved RV antifreeze to prevent freeze damage. The RV antifreeze must be pumped through the Aqua-Hot until the solution appears at the hot water side of a faucet.

The on-board water pump can be used (see illustration), or a separate pump can be hooked to the city water fitting. Refer to the Aqua-Hot owner's manual for complete winterizing instructions.

If the Aqua-Hot is not winterized, it must remain operational. If the system is operating from electric and there is a power outage, freeze damage may occur.

CAUTION:

Failure to winterize the Aqua-Hot with Non-Toxic FDA approved RV antifreeze during freezing temperature will result in serious damage to the Aqua-Hot. Refer to the Aqua-Hot owner's manual for detailed winterizing instructions.

CAUTION:

If the motorhome is hooked to shore power during the winter months and the Aqua-Hot is operating on the electric element, a temporary power outage can allow the Aqua-Hot to freeze resulting in damage.

WARNING:

DO NOT operate the diesel burner when the motorhome is located inside a building. Carbon Monoxide can accumulate which can be fatal.

Fuel Filter**Aqua-Hot Fuel Filter:**

The filter is located on the curbside of motorhome behind the fuel access door.

Filter Replacement:

Contamination levels in the fuel determine the frequency of element replacement. Fuel flow to the Aqua-Hot becomes restricted as the element gradually plugs up with contaminants, resulting in noticeable heating loss and/or hard starting. If this occurs, change the element as soon as possible.

As a guideline, change the filter when clogged (first indication of heat loss) or at the beginning of each heating season. Always carry an extra filter as one tank of contaminated fuel can plug a fuel filter. Replacement filters must have a 10-micron rating.

Gar-ber Filter: Model #R, 10 micron.

To Replace the Filter:

- ◆ Ensure the Aqua Hot Diesel switch at the galley is turned **OFF**.
- ◆ Spin the filter counterclockwise and remove from head. Remove old O-ring gasket on threaded stud.
- ◆ Install new O-ring supplied with filter. Ensure the gasket is seated in the groove around the filter canister.
- ◆ Apply clean lubricating oil to the new filter gasket and washer.
- ◆ Spin filter onto head until filter makes contact then tighten $\frac{3}{4}$ of a turn.
- ◆ Start Aqua-Hot and check fuel filter for leaks.

**NOTE:**

It may be necessary to cycle the diesel burner switch on and off a few times to thoroughly purge the fuel system of air.

Aqua-Hot Overview

General Layout:

An understanding of the general layout of the Aqua-Hot system will help in operating and troubleshooting the system.

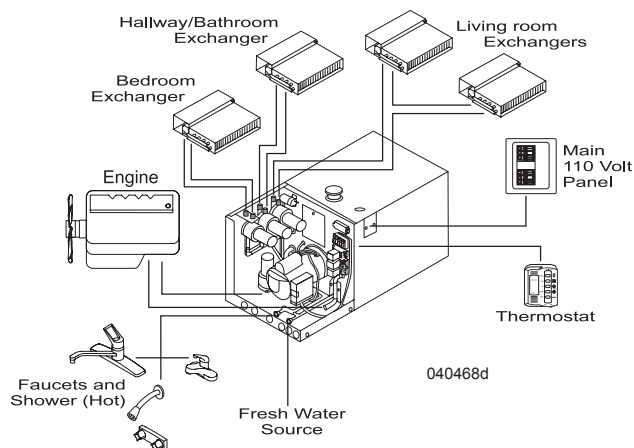

General Aqua-Hot layout

ELECTRIC BASEBOARD HEATER (OPTIONAL)

The baseboard heater operates from 120 Volts AC supplied by shore power or the generator. An adjustable thermostat and remote switch controls the operation of the heater.

To Operate the Heater:

- ◆ Hook to shore power or start the generator.
- ◆ Adjust thermostat to desired setting.
- ◆ Turn on the Heater switch.



060297b

NOTE:

The heater is rated at 1000 watts or 8.8 Amps. Use care when hooked to anything less than 50 Amp service.

TIP:

If heater operation discontinues or fails to operate, check the power supply. If the heater still does not operate, the Temperature Overload Switch may be tripped.

To Reset the Overload Switch:

- ◆ Turn off power supply.
- ◆ Remove grille to access the **Overload** switch.
- ◆ Using a pencil or small screwdriver to press the **red Reset** button.

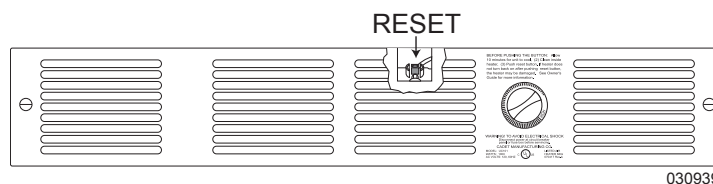

BEFORE PUSHING THE BUTTON: Allow 10 minutes for unit to cool, (2) Clean inside heater, (3) Push reset button. If heater does not turn back on after pushing reset button, the heater may be damaged. See Owner's Guide for more information.

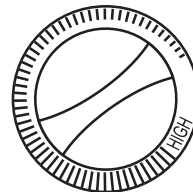

WARNING! TO AVOID ELECTRICAL SHOCK
Disconnect power at circuit breaker
panel or fuse box before servicing.
CADET MANUFACTURING CO.
MODEL: UC101 LISTED AIR HEATER 680J
WATTS: 1000 AC VOLTS: 120, 60HZ c UL US 070417 Rev.A

030940

WASHER-DRYER PREPARED

If the motorhome was not ordered with an optional washer-dryer, it will have a washer-dryer preparation package installed from the factory. The washer-dryer "prep" package includes the following items:

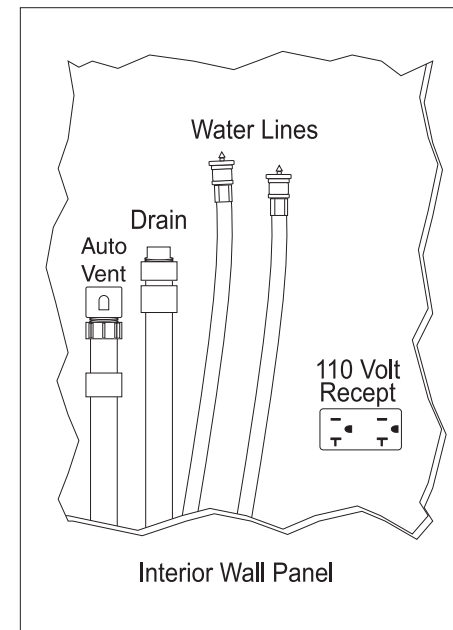

Location of specified parts may vary within wall panel depending on floor plan and model.

040495c

1. Color coded water supply lines. A red line for hot and a blue line for cold.
2. A 1½" waste water drain line with threaded cap, P-trap, and an automatic vent cap. This will drain the waste water into the grey water holding tank.
3. A 120 AC Volt receptacle located in the compartment.

NOTE:

Sidewall dryer vents are not part of the prep package. If a sidewall vent is to be installed, properly seal vent to sidewall.

If a washer-dryer is to be installed at a later date, follow all the manufacturer installation instructions. Listed here are further instructions which should be adhered to for safe and reliable operation:

- ◆ **DO NOT** connect the clothes dryer exhaust duct to any other duct, vent or chimney.
- ◆ **DO NOT** terminate the exhaust duct beneath the motorhome.
- ◆ Use proper length fastener when attaching exhaust vent to exterior sidewall. Stainless steel fastener are best suited for this as they will not rust.
- ◆ If the cabinet or closet in which a washer-dryer is installed does not have vented louvered doors, the manufacturer's installation instructions may require installation of vented doors or vents to be installed in the doors for sufficient circulation of air.

WASHER-DRYER (OPTIONAL)

The automatic washer-dryer is front loading with an extra large door opening for easier access. Several wash and dry programs are available along with variable water temperature settings.

- ◆ Washer-dryer operates on 120 Volt AC from shore power or generator.
- ◆ Washer-dryer uses approximately 12 to 20 gallons of water per wash cycle.

NOTE:

Only one of the following can be used at a time: Bedroom A/C or Washer-Dryer. This is due to the automatic appliance selector prioritizing appliance use to prevent electrical overload.

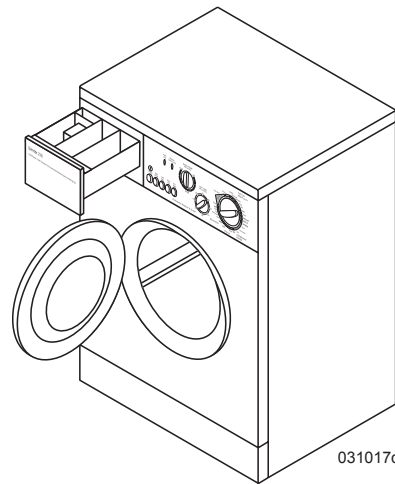
**INFORMATION:**

Refer to the washer-dryer manufacturer's manual in the owner's information file for detailed operating instructions.

WARNING:

Open a window or vent while operating the dryer. The washer-dryer can create negative air pressure inside the motorhome that can accumulate Carbon Monoxide or LP-Gas while operating fuel-burning appliances.

CAUTION:

DO NOT use the washer-dryer while traveling. Suspension movement, combined with the weight of the drum while in the wash cycle, can damage the internal components of the washer-dryer.

Test Procedure

Before using the washer for the first time, after winter storage or a long period of non-use, conduct a simple test procedure to verify that all the hardware and electronic components are functioning. Wipe the interior and exterior of the washer-dryer with a damp cloth to remove dust that has accumulated.

NOTE:

Perform this test before putting the washer-dryer in use for the first time or after. This will clear the water lines and drum of winterization antifreeze.

Test Procedure Requirements:

- ◆ Ensure water lines are secure and water valves are open.
- ◆ Hook to city water or turn on the water pump.
- ◆ Hook to shore power or start the generator.

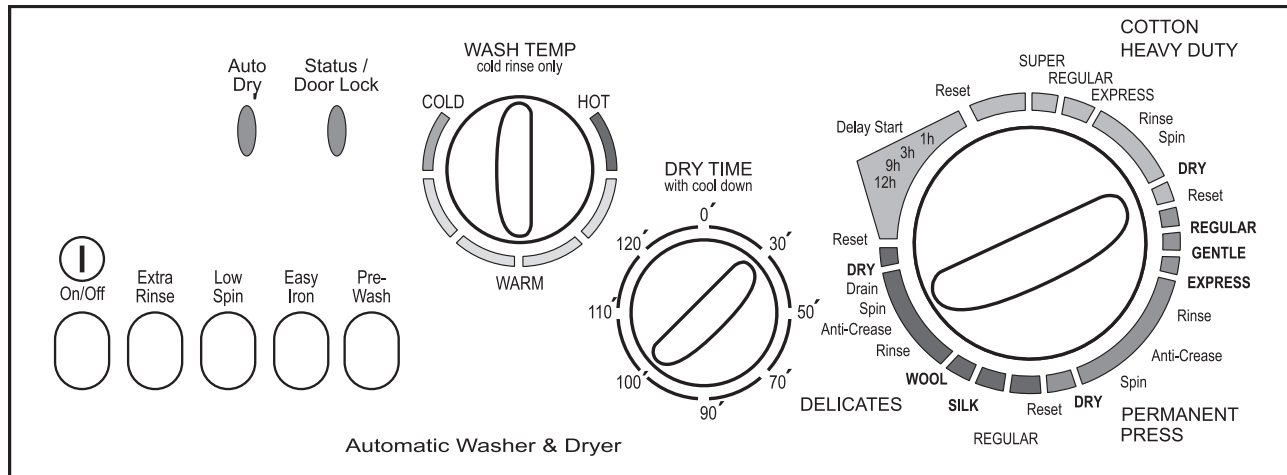

To Conduct the Test Procedure:

1. Set selector knob to **Reset**.
2. Set **Dry Timer** knob to 30 minutes.
Push the **ON/OFF** button to **ON**. Wait five seconds. The **Auto Dry** light should be on and the **Status** light flashes fast, then slow.
3. Set the selector knob to a wash cycle.
Set **Wash Temp** knob to **Warm**. Water flows into washer and the drum rotates both directions.
4. Set selector knob to **Reset**. Wait five seconds.
5. Set selector knob to **Spin**. Water drains and drum rotation increases.
6. Set selector knob to **Reset**. Wait five seconds.
7. Set selector knob to **Dry**. Dryer fan begins and the drum rotates both directions.
8. Set selector knob to **Reset**. Wait five seconds.
9. Set **Dry Time** knob to zero. The **Auto Dry** light goes off.

10. The door will unlock in two minutes or less. The **Status** light flashes fast, then slow. The door should now open.
11. Push the **ON/OFF** button to **Out (Off)** position. The **Status** light will go off.

WARNING:

DO NOT wash or dry articles that have previously been cleaned, washed, soaked or spotted with gasoline, dry cleaning solvents or other flammable or vaporous substances that could ignite or explode. DO NOT add gasoline, dry cleaning solvents or other flammable or explosive substances to the wash water.

CAUTION:

DO NOT use heat to dry articles containing foam rubber or similar textured, rubber-like materials.

To begin a wash load:

- ◆ Sort and pre-treat clothes.
- ◆ Add the measured amount of detergent suggested by the package directions (maximum two tablespoons).
- ◆ Load wash tray with detergent.
- ◆ Load the laundry loosely into the washer. Close the washer door.
- ◆ Turn the Wash Temperature knob to the desired temperature setting.
- ◆ Choose the desired washing cycle option using the Selector knob.
- ◆ Turn the power **ON**.
- ◆ After cycle is complete, wait two minutes for the door lock to release before attempting to open the door.

Washer/Dryer Maintenance

Occasionally wipe the exterior cabinet of the washer-dryer with a damp cloth or sponge. Wipe dry with a soft cloth. **DO NOT** use polish on plastic trim. In areas of hard water, detergent can accumulate in the drum. Obtain a packaged water softener. Add quantity as specified by the manufacturer directly to the drum. Run the washer through a complete cycle using hot water. Repeat the process if necessary. Remove hard water deposits using only cleaners labeled as washer safe. Wipe the inside of the washer-dryer door with a soft cloth to remove moisture. Periodically apply a thin coat of paste wax to the inner door, especially to the area that is immediately next to the door window. This will protect the door finish from laundry spills and discoloration.

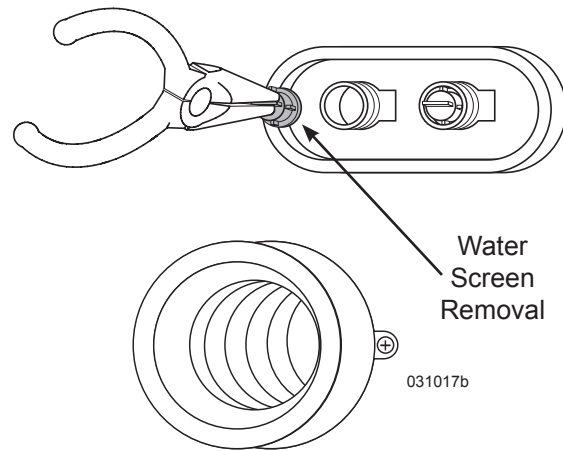

If water flow to the washer-dryer is reduced, the Hot and Cold water inlet screens may be clogged. Remove water pressure and undo water lines at the back of the washer-dryer. Use tweezers or needle nose pliers to remove screens from fittings. Clean and install screens and water lines. Hook to city water or turn on the water pump. Check for water leaks before using the washer-dryer.

NOTE:

Should the washer-dryer need removal for service, care should be taken as the washer-dryer weighs approximately 170 lbs. Proper accommodations should be made to avoid risk of injury or damage to the cabinetry.

Winterizing the Washer/Dryer

Winterize Using Air Pressure:

1. Hook an airline (regulated to 45 psi or less) to the water inlet of the motorhome.

2. Rotate Selector knob to a wash position with the Wash Temp setting on Warm. Press the power button to On. Air pressure will clear the Hot and Cold water lines.
3. After water lines are clear, rotate Selector knob to Spin. Allow the pump to drain the drum.
4. Set Selector knob to Reset and Timer to zero. The door will unlock in two minutes or less. Open door and pour in ¼ gallon of RV antifreeze.
5. Set selector knob to Spin. The pump will prime with antifreeze. Set selector knob to Reset and turn the power off.

WASHER (OPTIONAL)

The front-loading washer is a large capacity automatic washer that operates on 120 Volts AC from shore or generator power. The washer will use between 16 and 35 gallons of water per load, depending on cycles and water levels chosen, as well as the volume of laundry.

CAUTION:

DO NOT use the washer while traveling, as damage will occur to the washer and motorhome.

NOTE:

Due to the automatic appliance selector limiting use of appliances according to priority to prevent electrical overload, only one of the following can be used at a time: bedroom A/C or washer-dryer.

NOTE:

It is recommended to hook to city water and/or sewer when using the washing machine due to the potential large volume of water used.

INFORMATION:

The washer has many features. Refer to the manufacturer's manual in the owner's information file for detailed operating instructions.

Test Cycle

Before using the washer for the first time or after a long period of non-use, run a test cycle. The test cycle will confirm the unit is working correctly. Remove RV antifreeze that may be present and verify all hardware, plumbing and electronic components are functioning.

Test cycle requirements:

- ◆ Wipe the exterior and interior of the unit with a damp cloth to remove accumulated dust.
- ◆ Make sure water lines are secure and all the necessary valves are open to supply water.
- ◆ Hook to city water or turn on the water pump (must have sufficient water in tank).
- ◆ Hook up to shore power or turn on the generator.

Conducting test cycle:

1. Pour a solution of water and half the regular amount of detergent used into **Chamber II** of the additive dispenser.

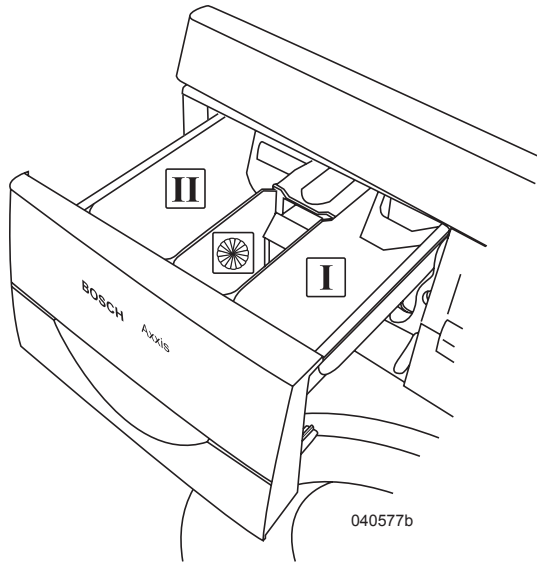
**NOTE:**

Front loading washers require a special detergent. If it is necessary to use top loading detergent use only $\frac{1}{4}$ to $\frac{1}{2}$ of the amount that would normally be used.

2. Close the detergent dispenser.
3. Set the program selector to **Power Temp Boost**. The ready control light will flash.
4. Press the **Start** button. The wash control light will turn on and the program starts. The **Door Locked** light will illuminate during the program. The wash control light will change to **Rinse/Spin**.
5. When **Finished** flashes, set the program selector to **Off**.

NOTE:

The program selector will not rotate as the cycle progresses. The cycle status lights indicate the operation being performed within the cycle. When all the cycle lights are off, the cycle is complete.

6. Select the water temperature; **Hot**, **Warm** or **Cold**.
7. Turn the program selector knob to the appropriate selection.
8. Push the **Start** button to start the wash cycle.

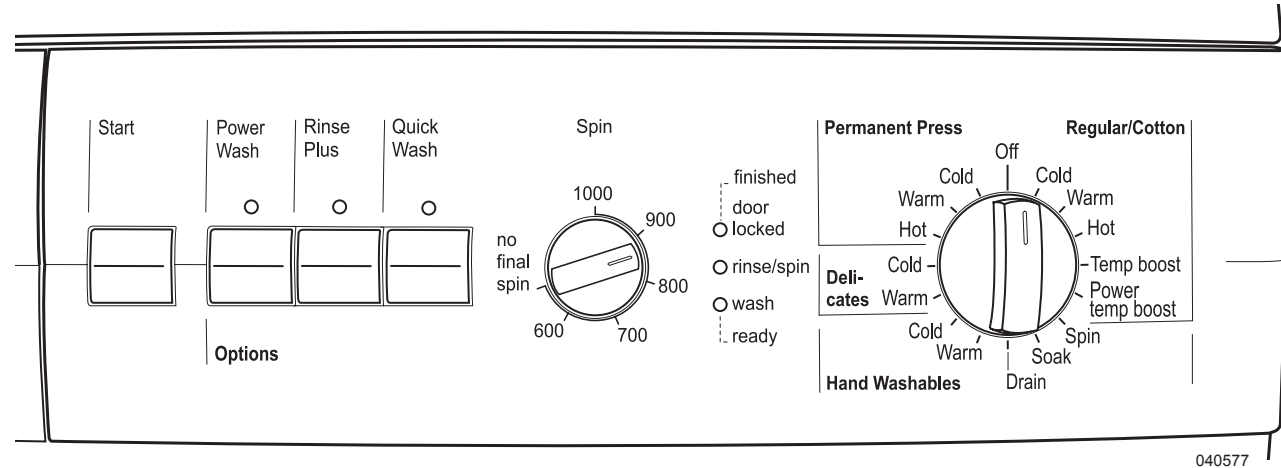
**Operating Instructions**

1. Measure soaking detergent and pour into chamber I. Pour appropriate amount of washing detergent/stain remover into chamber II.
2. Place laundry loosely into the washer. Load evenly to maintain washer balance. Mix large and small items.
3. If desired, add liquid fabric softener to the center bin of the dispenser tray then close tray.
4. Close washer door.
5. Select the water level.

NOTE:

Ensure there is room available in the grey tank if not hooked to sewer.

CAUTION:

DO NOT use chlorine bleach in this washer.

WARNING:

DO NOT wash articles that have previously been cleaned, washed, soaked or spotted with gasoline, dry cleaning solvents or other flammable or other vaporous substances that can ignite or explode. **DO NOT** add gasoline, dry cleaning solvents or flammable or explosive substances to wash water.

Cleaning the Washer

To clean the exterior, use hot soapy water or a mild non-abrasive cleaning agent. Rub dry with a soft towel. To clean the drum use a chlorine-free cleaning agent. Follow the manufacturer's instructions. Pour into washer and run through a complete cycle using hot water. Never use steel wool.

NOTE:

Cleaners used to remove hard water deposits must be labeled as safe for washers.

Cleaning the Drain Pump:

1. Turn off the washer breaker or turn the program selector to the **Off** position.
2. Open the panel at the bottom right corner of the washer.
3. Drain water from washer into a container (4.4 gallons) by pulling the drain hose from storage clip and remove cap at end of hose.
4. After water has drained replace cap on end of hose and return hose to storage clip.
5. Remove pump cap by turning counter-clockwise. Take out any loose debris or lint.
6. Clean any residue from the pump cap and install.

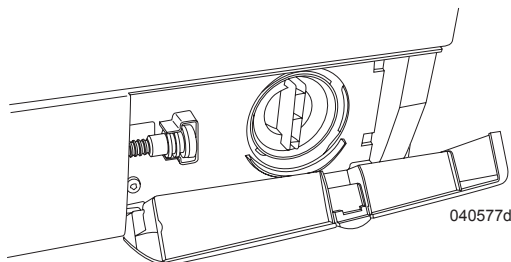

Washer Drain

Cleaning the water inlet strainers:

1. Shut off the hot and cold water supply.
2. Select any program except for spin or drain.
3. Press the **Start** button and allow 40 seconds of operation.
4. Turn the program selector to the **Off** position.
5. Disconnect the hoses from the hot and cold shut off valves. Clean the strainers on the hoses under running water and reconnect the hoses to the shut off valves.
6. Disconnect the hoses at the back of the washer and remove the strainers using a pair of needlenose pliers.
7. Rinse strainers under water and re-install. Connect hot and cold supply hoses to the washer and turn on the water supply.

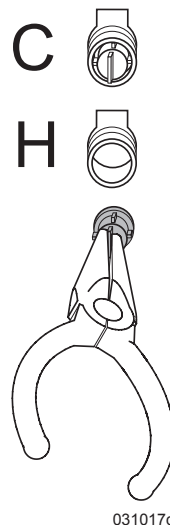

Winterizing the Washer

To Winterize the Washer:

1. Shut off the hot and cold water supply.
2. Disconnect and drain water inlet hoses.
3. Put one quart of RV type antifreeze in the drum.
4. Set the program selector knob to **Drain** for about 30 seconds.
5. Disconnect power to washer.

NOTE:

When returning the washer to service be sure to run through a complete cycle with a cup of detergent to purge the antifreeze from system before using the washer for laundry.

DRYER (OPTIONAL)

The front-loading dryer operates only on 240 Volts AC from 50 Amp shore power or the 10 Kw generator (if equipped).

INFORMATION:

Read the instructions in the dryer manufacturer's Care and Operations Guide located in the owner's information file.

CAUTION:

Open a window or vent while operating dryer. Negative air pressure inside the motorhome can be dangerous while operating fuel burning appliances.

CAUTION:

DO NOT use the dryer while the motorhome is in motion as it can damage internal components of the dryer.

NOTE:

Before using the dryer, wipe the dryer drum with a damp cloth to remove dust that has accumulated from storage and traveling.

NOTE:

The breaker for the dryer is located at the middle of the motorhome.

CAUTION:

DO NOT dry articles that have previously been cleaned, washed, soaked or spotted with gasoline, dry cleaning solvents or other flammable or vaporous substances that can ignite or explode. **DO NOT** use heat to dry articles containing foam rubber or similar textured, rubber-like materials. Clean the lint screen (located inside the dryer door) after each use. Keep the exhaust opening and adjacent areas free from accumulation of lint, dust and dirt.

Dryer Operation:

Dryer operation requires 50 Amp shore power or 10 Kw generator power.

CAUTION:

This dryer is a 240 Volt AC appliance only. Operate this appliance only when hooked to 50 Amp shore power or when using the 10 Kw generator.

To Operate the Dryer:

1. Press **Door** button to open door. Load laundry loosely into dryer and close the door. Allow space for the clothes to tumble freely.
2. Turn the cycle selector knob to the recommended cycle. Use the **Econodry** setting to dry most heavy-weight and medium-weight loads.
3. Push the **START** button.
4. To stop the dryer, open the door, or press the **OFF** button.
5. An audible signal will sound when cycle is complete.

Dryer Maintenance**Clean the lint screen after each load:**

- ◆ Open the door and remove lint screen.
- ◆ Roll lint off screen with fingers. **DO NOT** rinse or wash screen to remove lint. Wet lint is hard to remove.
- ◆ Push the lint screen firmly back into place and close the door.

CAUTION:

DO NOT run dryer with lint screen loose, damaged, blocked or missing. Doing so can cause overheating and damage both the dryer and fabrics.

WARNING:

Never use flammable cleaners to clean any part of the dryer. Failure to comply with this warning could result in fire, explosion, injury, and/or death.

To Clean the Dryer Drum:

- ◆ Apply a paste of powdered laundry detergent and very warm water or a liquid, non-flammable household cleaner to the stained area. Rub with soft cloth until all excess dye is removed.
- ◆ Wipe drum thoroughly with cloth dampened with clean water.
- ◆ Tumble a load of cloths or towels to dry drum.

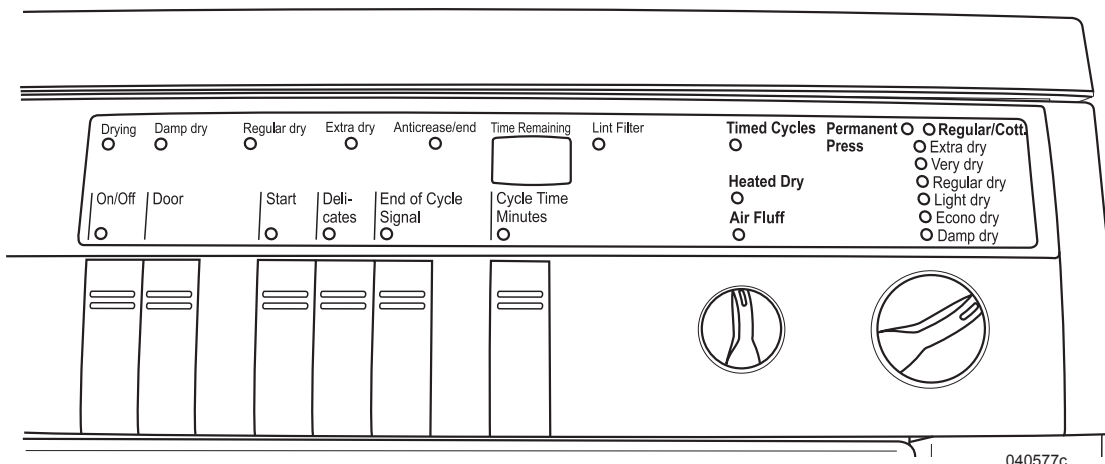

040577c

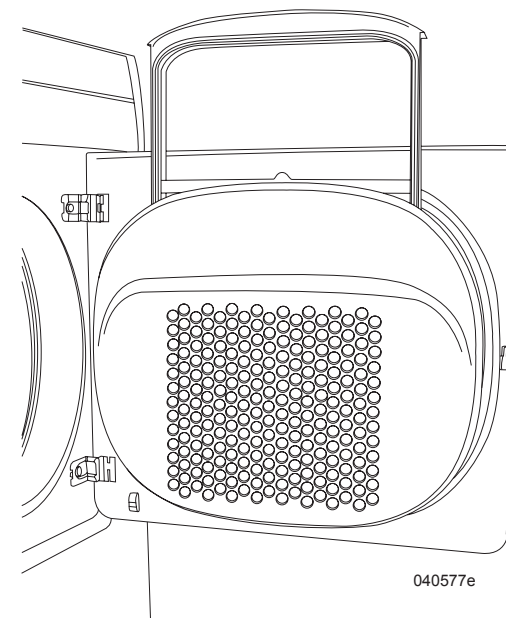

040577e

DISHWASHER (OPTIONAL)

The dishwasher requires an average of 2.4 gallons for a standard wash cycle. Variable water pressure, specific temperatures (up to 165° F) and a flexible racking system are some of the features.

Dishwasher Compartment Capacity:

- ◆ 7 dinner plates
- ◆ 7 soup bowls
- ◆ 7 place settings of cutlery
- ◆ 7 dessert plates
- ◆ 7 saucers
- ◆ 7 cups

Requirements for Operation:

- ◆ Power requirement is 120 Volts AC 15 Amp supplied by shore power or the generator.
- ◆ Hook to city water or turn on the water pump. Inlet water pressure is 4.3 psi (minimum) to 120 psi (maximum).
- ◆ The motorhome must be level.

To Operate the Dishwasher:

1. Remove all scraps of food and load dishes. Wash water ejects from the spray arm. Care needs to be taken when loading the dishes to ensure there is sufficient space for the water to reach all areas and that nothing interferes with spray arm movement.
2. Located inside the dishwasher dispenser are two compartments: Pre-wash and Main Wash. The Pre-Wash markings are in one teaspoon increments. Main Wash compartment markings are in two teaspoon increments.

NOTE:

Use only powdered detergent. Liquid and tablets are not recommended for use. It is highly recommended to regularly use a liquid rinse agent for best drying results. The rinse agent dispenser is located inside the dishwasher and holds approximately 1.7 fluid ounces of rinse agent.

3. Press the **Power Button** to turn the dishwasher **ON** and **OFF**. If the Power button is pressed in mid cycle, the wash program will end and water will pump out. Opening the door will automatically power up for 30 seconds **ONLY**.

4. Select the desired wash program. Standard programs are Heavy, Normal, Fast, Delicate and Rinse.

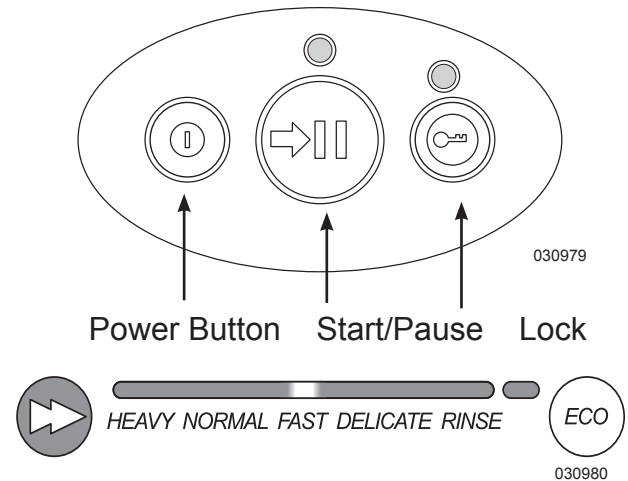

5. Ensure the drain filter is flush with the filter plate and the spray arm can easily rotate.
6. Close the dishwasher and press the **START/PAUSE** button to begin wash program. To pause, press the **START/PAUSE** button and wait for three beeps prior to opening. Simply press the **START/PAUSE** button to restart.
7. Six beeps indicate the end of the wash program. The drying fan will continue to run for a set time or until the door is opened.

NOTE:

It is normal for some water to remain in the drain filter area after the wash program is complete.

NOTE:

In the event the dishwasher is operating and a power outage occurs, the dishwasher will stop and may not open. When power is restored, the dishwasher will resume the wash program.

Preparing the Dishwasher for Storage:

If the dishwasher is not used for an extended period, it is recommended to ensure the baskets are empty. Clean and dry the inside compartment. Leave the door ajar to allow air circulation. Shut off power and water supplies to the dishwasher.

INFORMATION:

For Winterization of Dishwasher, refer to the Dishwasher Manufacturer owner's manual.

CENTRAL VACUUM (OPTIONAL)**Operation**

- ◆ Start generator or plug into shore power.
- ◆ Lift lid on wall receptacle to start vacuum. Insert the hose in the receptacle and release lid.
- ◆ Connect desired attachment on hose and start vacuuming.

NOTE:

Consult OEM manual for detailed operation and maintenance.

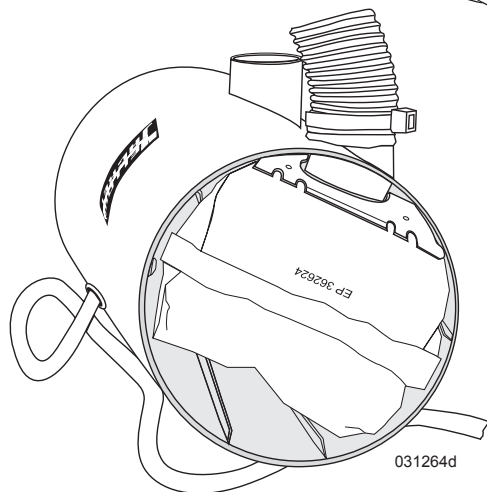
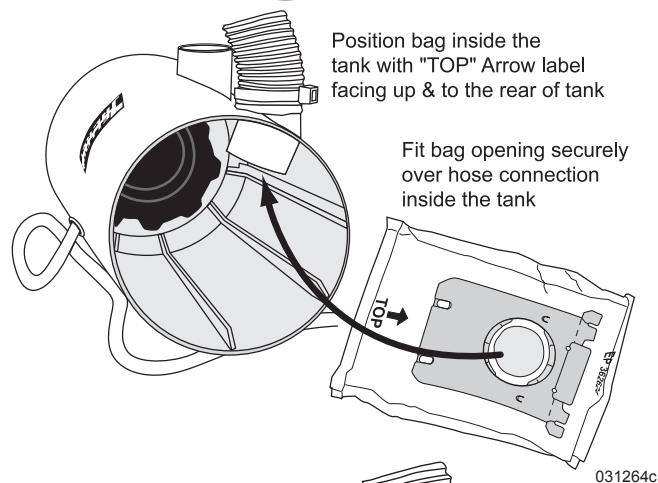
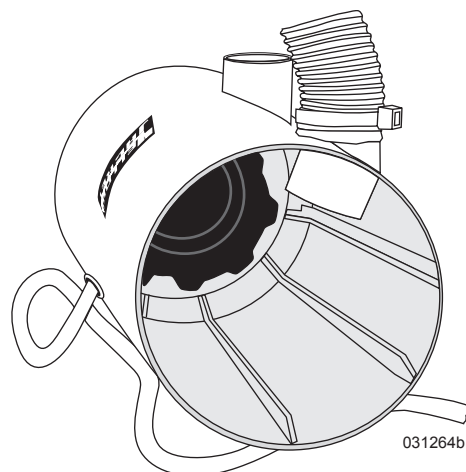
**Maintenance**

Vacuum has a thermal protector built into the motor to prevent overheating. If motor will not operate, it will automatically reset in about ½ hour. If motor brushes or bearings are worn out, the circuit protector will trip off again after a short period of time. If this happens, contact a qualified service representative.

Changing the Bag:

To keep your vacuum at top efficiency, change the filter bag at regular intervals. To maintain cleanability, replace filter bag when it is about ¾ full.

1. Unplug the power unit from grounded outlet.
2. Rotate the bag cover counterclockwise and remove cover.
3. With a finger on each side of the inlet, slide the bag off the inlet tube.
4. Pull the center cardboard tab to automatically seal the bag and prevent dust from leaking out.
5. Remove the bag from the vacuum and discard. **DO NOT** reuse.
6. Check support (motor) filter.
7. Unfold the new “OX” bag and insert into the vacuum so the center cardboard seal tab is toward bag cover. The top arrow should point to the bag cover.
8. With a finger on each of the cardboard tabs, slide the bag on the inlet tube.
9. Line up the mark on the bag cover with the unlock symbol and rotate clockwise to lock symbol.

Replacing & Cleaning the Support (Motor) Filter:

1. Inspect during each bag change. The filter should be cleaned every fifth bag replacement or when excessively dry.
2. Remove dust bag as previously instructed.
3. Locate the support (motor) filter in the bottom of the bag compartment and lift out.
4. Clean by rinsing under warm water and let air dry if heavily soiled. If the filter is torn or obstructed it must be replaced.
5. Reinstall dry motor filter before use, making sure filter is tucked under retaining tabs.
6. Reinstall bag as previously instructed.

WARNING:

To reduce the risk of fire, electric shock or injury:

- ◆ Unplug and disconnect power before servicing.
- ◆ Avoid wet surfaces.
- ◆ Use only manufacturer's recommended attachments.
- ◆ DO NOT use without dustbag and/or filters in place.
- ◆ DO NOT pick up anything that is burning or smoking, such as cigarettes, matches, or hot ashes.
- ◆ Use extra care when cleaning on stairs.
- ◆ DO NOT use to pick up flammable or combustible liquids such as gasoline or use in areas where they may be present.

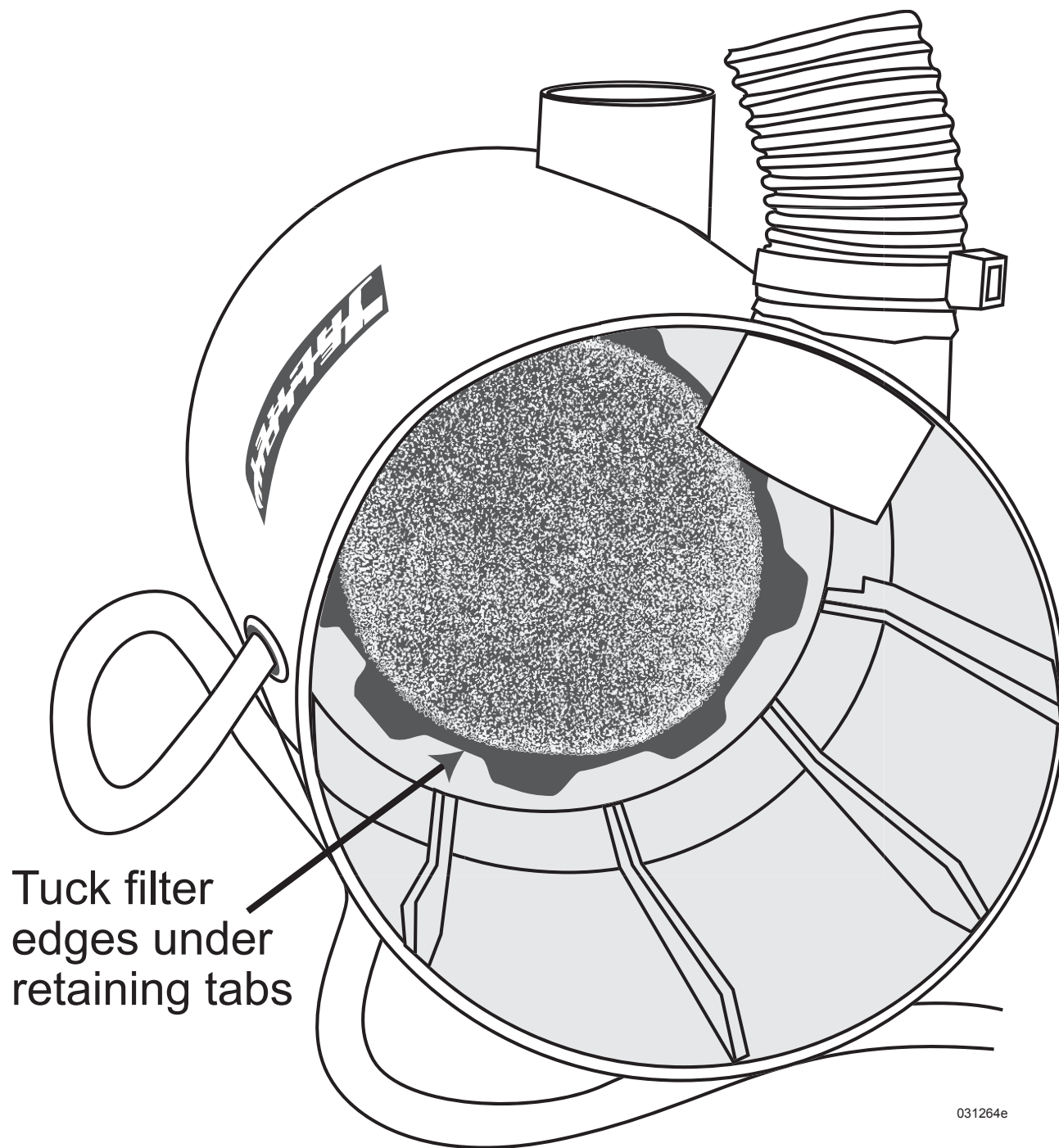

031264e

THE EXECUTIVE 07

EQUIPMENT — SECTION 5

EQUIPMENT - INTRODUCTION	122	AIR MATTRESS BED (OPT)	135
ENTRY STEP	122	Troubleshooting	135
Operation	122	SUPER SLIDE (OPT)	136
Stepwell.....	123	POWER SUPER SLIDE (OPT)	136
ENTRY DOOR	123	LADDER - REAR	137
Air Seal.....	123	CITIZENS BAND (CB) RADIO - PREP	137
Latch Adjustments	124	CITIZEN BAND (CB) RADIO (OPT)	137
Screen Door	124	GPS NAVIGATION	138
KEYLESS ENTRY	124	SATELLITE RADIO (OPT)	138
Operation	124	ALADDIN™ SYSTEM	138
SLIDE-OUT OPERATION	125	Operations	139
Extending & Retracting Slide Rooms.....	126	TV & ENTERTAINMENT COMPONENTS	142
Manual Override (HWH)	127	Television (Front) Lockout Feature	142
Manual Override-Lippert.....	127	Connections - Cable TV, Computer & Phone ..	143
Bedroom Slide-Out	128	Television Inputs	143
AWNINGS	128	Television - Ceiling Mounted (OPT)	143
Slide-out Cover	128	Antenna Boost	143
Entry Door Awning - Girard Automatic (OPT)	129	TV Antenna	143
Window Awning (OPT)	129	Television/Entertainment System - Front	144
Patio Awning - Girard	129	Television-Bedroom.....	145
Awning Care & Cleaning	131	UNIVERSAL REMOTE	145
Storm Precautions	131	SATELLITE	146
FANS	132	Stationary System.....	146
Bathroom Fan	132	In-Motion System (OPT).....	148
Exhaust Fan	132		
Bedroom Ceiling Fan (OPT)	133		
POWER SUNVISOR	133		
BLINDS COCKPIT (OPT)	133		
DOOR - SLIDING	133		
PRIVACY DRAPE- ELECTRIC (OPT)	133		
SEAT CONTROLS	134		
Swivel Seats	134		
SOFA BED CONVERSION	134		

EQUIPMENT - INTRODUCTION

This section covers the basic operation and care of equipment found in the motorhome, most of which are provided for entertainment and comfort. More detailed information about specific equipment may be found in that particular manufacturer's manual. Optional equipment will also be discussed in this section which may not apply to all motorhomes.

INFORMATION:

Detailed information with CAUTION or WARNING instructions for the various electronics, other than what is provided in this section, can be found in that specific manufacturer's manual.

ENTRY STEP Operation

The exterior electric entry step features retractable steps, automatic retraction with the ignition key in the **RUN** position and a last out feature. The bar light indicates the circuit is active when illuminated.

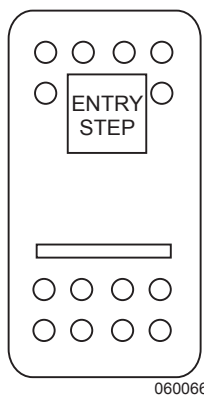

*Located on
passenger console.*

NOTE:

When dry camping it is important to note that when the switch is illuminated, all step circuits are active and drawing current from the chassis battery.

Operating the Entry Step:

1. With the entry door open, turn the step switch on.
2. Close the door. The step should retract and lock in the **IN** position.
3. Open the door. The step should extend and lock in the **OUT** position. The step will retract when the door is closed.
4. When the switch is turned off, the step should remain in the extended position. Close the door and turn on the ignition switch. The step will retract for travel.
5. With the power switch off, the step extended, the entry door closed and the ignition turned on, the ignition override system will engage to automatically retract the step.
6. Turn the ignition off and open the door. The step will extend and lock in the **OUT** position. This is the “last out” feature. When the ignition is on the step will always activate with door movement, regardless of the power switch position.

CAUTION:

High curbs can impede step operation. Use care when parked on side streets.

If the step fails to operate:

- ◆ Verify that the step switch is ON.
- ◆ Check the main power supply for the step: a 20 Amp fuse located at the rear run box on the R4 circuit board.

- ◆ A magnetic door jam switch is used to control step operation. Use a separate magnet to apply a “trigger” to the door jam switch. Rotate test magnet to align polarity field.
- ◆ A 5 Amp ATO blade fuse is used to illuminate the **STEP OUT** dash warning light. The fuse is located at the front run box, labeled **STP IGN**.

WARNING:

If the motorhome is driven with the step in the extended position there is the possibility of causing major damage to both the step and the motorhome.

CAUTION:

If the Step Out warning indicator lamp is illuminated while the motorhome is in motion, the entry step is either partially or fully extended. Repair the step as soon as possible to avoid serious damage to the entry step or motorhome.

Lubrication:

Keeping the step clean is essential for smooth and reliable operation. Before applying a dry spray lubricant or graphite on the slide mechanisms, thoroughly clean the step using a pressure washer or a stiff nylon bristle-brush and automotive detergent. Allow the step to thoroughly dry.

CAUTION:

Keep fingers, clothing and other hardware away from moving components.

NOTE:

Clean and lubricate step more frequently in adverse weather conditions. Mud, snow, road salts and sand quickly break down lubricant and corrode painted surfaces.

NOTE:

Only use a dry spray lubricant or graphite on the slide mechanisms. DO NOT use Kwik Lube spray lubricant. The slide mechanisms will become clogged with road grime accumulation.

- ◆ Lubricate points with graphite or a dry spray lubricant.
- ◆ Run step in and out several times to work into surfaces.
- ◆ Repeat as necessary.
- ◆ Remove excess lubricant.
- ◆ Periodically apply di-electric grease at electrical connections.

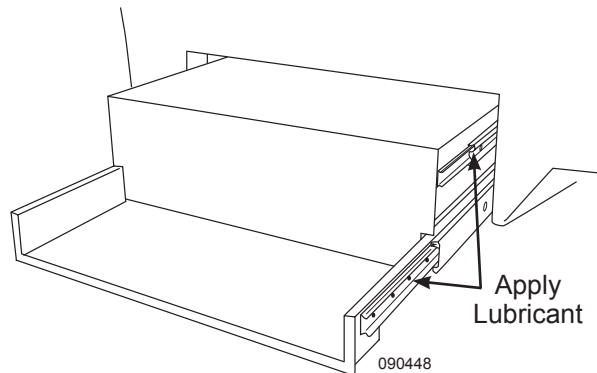
**Stepwell**

The interior stepwell features a cover, step lighting and a storage compartment in the upper step. This compartment is ideal for storing items such as gloves, tire pressure gauge, flashlights or outside slippers.

Cover:

An electrically operated stepwell cover will extend and retract using the switch on the curbside armrest. Power is supplied by a 15 Amp fuse in the roadside front electrical bay.

To operate the Stepwell Cover:

1. Turn **ON** the Battery Cut-Off switch.
2. Press and hold the Stepcover switch to the desired direction. Release the switch to stop movement.

CAUTION:

When operating the stepwell cover, make sure there are no pets, shoes or other obstructions in the stepwell area. **DO NOT** operate the stepwell cover while standing in the stepwell area.

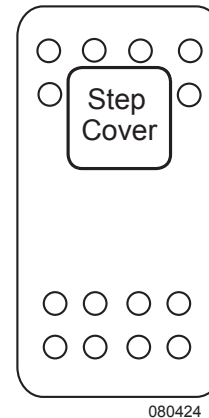
**ENTRY DOOR**

The entry door incorporates three separate seals to eliminate wind noise during travel. The door uses two separate locks for safety and security: the door handle and a dead bolt. The door handle incorporates a primary and secondary latching system used to ensure secure and safe latching. Adjustments can be made to help maintain entry door performance.

Air Seal

The entry door is equipped with a one-piece air seal to reduce wind and road noise.

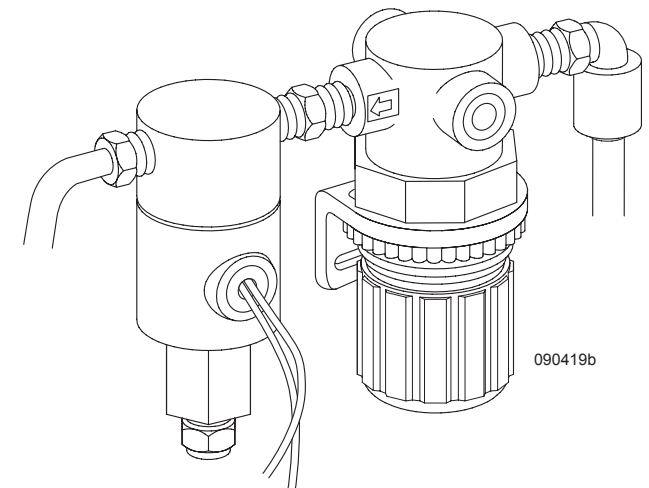

Door Seal Regulator: Located in curbside generator compartment

- ◆ The seal automatically inflates when the engine is running and the transmission shift selector is placed in Drive.
- ◆ The entry door seal will inflate to approximately 3 to 4 psi.
- ◆ The pressure regulator control valve is located behind the front cap on the curb side of the generator.
- ◆ When the transmission is placed in neutral, the entry door seal will deflate.

CAUTION:

If the pressure regulator should require adjustment, do not exceed 5 psi. Damage to the seal may occur.

Latch Adjustments**Adjusting the Entry Door Latch:**

- ◆ Determine which bolt needs adjustment.
- ◆ Observe the latch and strike bolt alignment while slowly closing the entry door. **DO NOT** attempt to latch if alignment is off. If the alignment is correct, allow the latch to catch in the first (primary) position only.
- ◆ The latch should move to the second position with just slight pressure applied to the entry door. Upper and lower latches should be evenly timed. Press on the entry door to see if there is further movement of the door.
- ◆ The handle should operate with little effort to open the entry door. Excess amounts of pressure indicate the bolts are set too far back.

- ◆ With an Allen Wrench, loosen the movable strike bolt. Make all adjustments in small increments. Tighten the bolt firmly after making adjustments. The bolts should have slight up and down movement for vibration control in travel.
- ◆ Test the operation of the dead bolt lock to ensure proper function.
- ◆ Apply silicone weekly to the entry door rubber gaskets to prevent squeaking while the motorhome is traveling. Use a one inch sponge paint brush, sprayed with silicone, for easy application.

CAUTION:

When operating the entry door ensure the dead bolt latch is fully in the unlock position prior to closing the entry door. Failure to do so can result in damage to the dead bolt and/or entry door.

Screen Door**Changing the Glass in the Screen Door:**

- ◆ The screen slider is Lexan and can be bowed for removal and replacement.
- ◆ Replace with new Lexan and reverse the procedure.

Adjusting the Screen Door:

- ◆ Loosen the chrome bolts on the hinge side of the screen door: Two on each of the three hinges (six hinges total).
- ◆ Slots in the steel hinge allow for in and out movement.

- ◆ Adjust the screen door to fit. The hinge should fit tightly to the trim of the door when the screen door is latched and the door is open.

Removing the Screen:

- ◆ The top half of the screen door is removable to allow clear viewing through the entry door glass while traveling.
- ◆ Rotate the clips to remove the top half of the screen door. Store for travel.

KEYLESS ENTRY**Operation****Key Fob:**

1. Locks entry door.
2. Unlocks entry door.
3. Locks and unlocks all compartment doors.
4. Horn.

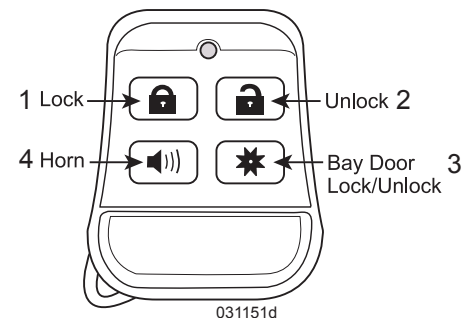
**NOTE:**

Key fob operation distance is approximately within 50 feet of the motorhome. If the door locking mechanism is not audible, marker lights will flash when the doors are unlocked or locked.

Locking Doors with Keypad:

Regardless of the configuration of the system, locking operation (lock all doors) is accomplished by pressing and holding down the first button (1) 1 - 2 seconds. An access code is not needed to lock the doors.

Unlocking doors with keypad and other secure operations:

After access codes have been assigned, secure operations can be accomplished by enabling the keypad. The keypad is enabled by entering a valid five digit access code. Entering the correct access code alone will not initiate a secure operation. If the lock/unlock (1) button is not pressed within five seconds after the access code was entered, then the keypad reverts back to a disabled state. If an unassigned button or no button is pressed while the system is enabled, the keypad reverts back to disabled state.

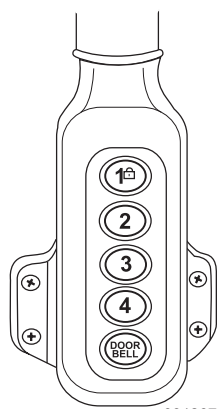

Keyless Entry:
Located on entry door grab handle.

NOTE:

Use of entry door deadbolt along with door lock will reduce unauthorized entrance into motorhome.

Factory Access and Authority Default Codes:

NOTE:

For Access and Authority codes, consult OEM manual.

Assign New Access Codes:

- ◆ Press the middle (3) button for five seconds, then release after the keypad provides a confirmation beep. The backlighting LED of the keypad will flash.
- ◆ Enter in the five digit authority code. Keypad will provide a steady beep that stops after an access number has been entered.
- ◆ Press and release the button that corresponds to the access number. For example, press (1) first button for access #1 and press (2) second button for access #2.
- ◆ The new code will be assigned to this access number. The keypad will provide a confirmation beep after this single button press.
- ◆ Enter in your new five digit access code. The keypad will provide confirmation beeps.
- ◆ Re-enter new access code. The keypad will provide confirmation beeps.
- ◆ Ensure possession of entry door keys and test the new access code.

WARNING:

Ensure possession of entry door keys prior to testing new personal code.

Up to four different access codes can be assigned at one time. As additional access codes are defined, pre-existing access codes are overwritten. For example, if a new access code is assigned for access #3, the previous access #3 code is no longer valid.

INFORMATION:

Consult the OEM manual for further information.

NOTE

During any service work, it is recommended all key fobs be left with the motorhome for thorough testing and check procedure.

SLIDE-OUT OPERATION

Slide room operation uses safety features to prevent mechanical damage or physical harm. Slide room(s) will not operate until all safety requirements are met.

Safety Requirements:

- ◆ The ignition must be **OFF** when extending slide rooms.
- ◆ The park brake must be applied.

CAUTION:

Never move the motorhome with any slide room extended. Perform the slide room operation with the air suspension system full.

CAUTION:

Extensive damage could occur to the slide-out room and awning when extending the slide-out room in snow, sleet, ice or freezing rain conditions. In such conditions, if the slide-out room is extended, clear the awning and ensure free movement prior to operating the slide-out room.

CAUTION:

DO NOT leave the slide room extended during severe weather. Conditions such as high winds or heavy rain may cause damage. Rain water can pool on the slide room awning, adding weight and causing the awning to sag. Retract the room in small increments to allow water run off. Extensive damage could occur to the slide room and awning if extended in snow, sleet, ice or freezing rain. In such conditions, if the slide room is extended, clear the awning and ensure free movement prior to operating slide room.

Guidelines to ensure long life of slide system:

- ◆ **Inspect** roof of the slide for debris such as pine needles, dirt, leaves, sticks, etc. Debris left on the top may cause damage to the seals during retraction. If debris is present, wash with soap and water, then rinse.
- ◆ When the room is out, **inspect** the wipe seal for dirt or other foreign material and for tears.
- ◆ If the slide room leaks, fully retract the room. If necessary, tape exterior opening closed with duct tape until repairs to the motorhome can be completed.
- ◆ Open a window or vent to equalize pressure during slide operation.

CAUTION:

Firmly latch all cabinet doors adjacent to the slide before extending or retracting the rooms. Damage to doors or the fascia may occur.

NOTE:

Dirt and grit trapped under the slide room could result in damage to the floor. If the motorhome has a ceramic tile floor ensure the floor is clean before retracting the slide room. Trapped dirt or grit under the slide room can scratch the floor surface. Never move the motorhome with the slide room extended.

NOTE:

DO NOT use petroleum based products on the slide seal. Petroleum based products can damage the paint and will cause premature aging of the rubber seal.

Extending & Retracting Slide Rooms**To Extend or Retract Slide Rooms:**

- ◆ Clean the floor of dirt or grit that could result in damage during operation.
- ◆ Confirm there is enough clearance inside/outside the motorhome for the room to extend/retract.
- ◆ Retract hydraulic jacks (if equipped). Start the engine. Press Travel Mode on air level control panel. Allow time for the air suspension to support the chassis.

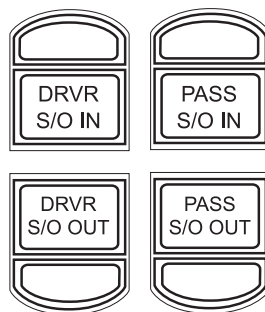

060297b

- ◆ Turn off the engine. Ensure park brake is applied when extending to the **OUT** position.
- ◆ Confirm the house batteries are fully charged.
- ◆ Turn on interior house power.
- ◆ Ensure all people, pets and objects are clear of the slide room path.
- ◆ The switch for the slide room is located on the overhead compartment above the co-pilot seat. Press and hold the slide room switch to the desired (**IN** or **OUT**) position.
- ◆ Release the switch anytime to stop room movement. The drive motor will not automatically stop; the switch must be released. A change in motor sound indicates full extension/retraction.

CAUTION:

Continuous operation of the slide room can drain the batteries and damage the motor by overheating.

WARNING:

The outside area must be clear of obstruction that can restrict slide room operation. Ensure there is five or more feet of clear space outside the slide room prior to extending the room or damage to the slide, the motorhome or property can occur. When retracting the slide room, ensure there is sufficient clearance inside the motorhome.

Manual Override (HWH)

If the slide room does not operate, a safety feature may be engaged to prevent room operation.

If the slide room does not respond from the switch:

- ◆ Is the ignition key **OFF** when extending room to the **OUT** position?
- ◆ Is the park brake applied?

If the slide room does not operate after checking the safety requirements:

- ◆ Ensure all electrical connections at the switch are good.
- ◆ Ensure fuse is good, the house batteries are fully charged and the battery cut-off is on.

If the pump motor operates but the room does not move:

- ◆ Check the two fuses adjacent to the hydraulic pump. If the fuses test good and the room does not operate, it is possible to manually retract the slide. Dual galley slide rooms use different hydraulic components. Several people (as many as eight) are needed to push in the room.
- ◆ It may be necessary to contact a repair facility to have the problem diagnosed and repaired.

To Move the Slide room manually:

1. Access the slide room hydraulic pump in generator compartment at front of the motorhome.

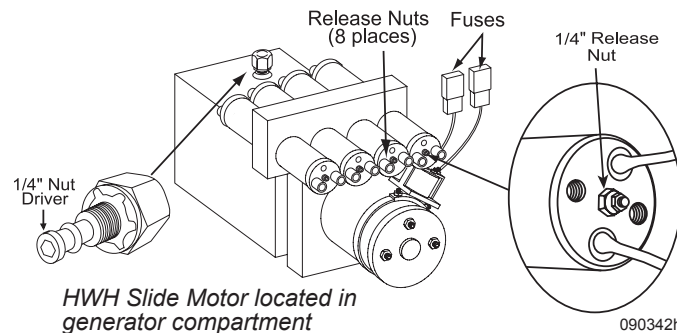

HWH Slide Motor located in generator compartment

2. Use the 1/4" nut driver on the end of the reservoir cap, to turn the release nuts on the solenoids counterclockwise. **DO NOT** exceed 4 1/2 revolutions, as damage to the solenoids may result. The room may move slightly when valves are opened and internal pressure is released.
3. Line up an equal distance along the outside wall. **DO NOT** push on the flange.
4. In synchronized movements, push the room in with repeated attempts.
5. Close the release nuts when the room is fully retracted.

NOTE:

The slide room is heavy and will require several people to push the room into position. When the slide room is in the fully retracted position, tighten the release nuts to hold the room in place. DO NOT over tighten.

Manual Override-Lippert

A safety feature may be engaged to prevent room operation if the slide room does not operate.

If the slide room does not respond from the switch:

- ◆ Is the ignition key **OFF** when extending room to the **OUT** position?
- ◆ Is the park brake applied?

If the slide room does not operate after checking the safety requirements:

- ◆ Ensure all electrical connections at the switch are good.
- ◆ Ensure fuse is good, the house batteries are fully charged and the battery cut-off is on.
- ◆ Check fluid level in reservoir. Maintain fluid within 1/2" from top of reservoir when slideouts are retracted.

To move the Slide room manually:

1. Turn off **House** and **Chassis** battery disconnect switches.
2. Remove vertical slide facia on both ends of slide room inside motorhome.
3. Disconnect 12 Volt DC wires leading to locking mechanism.
4. Remove six self-tapping screws holding lock to sidewall.
5. Slide lock out along wall.
6. Access the slide room hydraulic pump at curbside front compartment.

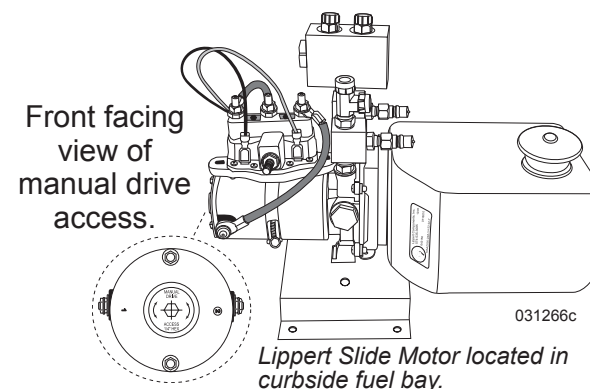

Lippert Slide Motor located in curbside fuel bay.

7. Remove plastic cover labeled **Manual Drive** at end of pump assembly.
8. Insert a ¼" hex bit connected to a cordless drill, ratchet or screwdriver.
9. Turn clockwise to extend slideout or counterclockwise to retract slideout.
10. Remove hex bit and reinstall plastic cover.

Bedroom Slide-Out

The bedroom slide-out operates electrically using safety features to prevent mechanical damage or physical harm. Prior to moving the slide-out, firmly latch cabinet doors located adjacent to the slide-out. Damage to the door or fascia can occur.

To Extend the Bedroom Slide-out:

- ◆ Confirm that there is at least five feet of clearance outside the motorhome for the slide-out room to extend.
- ◆ Ensure the ignition key is in the **OFF** position.
- ◆ Confirm the house batteries are fully charged.
- ◆ Interior house power must be on.
- ◆ Locate the control switch for the slide-out.
- ◆ Ensure all people, pets and objects are clear of the slide-out room path.
- ◆ Press and hold the slide-out room switch in the **OUT** position.
- ◆ Release the slide-out switch when the room is fully extended (a change in motor sound indicates full extension). The slide-out drive motor will not stop automatically; the switch must be released.

WARNING:

Firmly latch all cabinet doors adjacent to the bedroom slide-out before extending or retracting the room. Damage to doors or fascia can occur

CAUTION:

Dirt and grit trapped under the slide-out could result in damage to the floor. Continuous operation of the slide-out could cause a drain on the house batteries and damage to the motor from overheating.

NOTE:

DO NOT leave the slide-out room extended during severe weather. Conditions such as high winds or heavy rain may cause damage.

To Retract the Bedroom Slide-out:

- ◆ Check for sufficient clearance inside the motorhome before retracting the slide-out room.
- ◆ Clear the floor to ensure there are no objects that could result in floor or slide-out damage during retraction.
- ◆ Remove any debris from the top of the slide-out room.
- ◆ Prior to retracting the slide-out room, start the motorhome. Allow the air bags to fully inflate to normal travel height.
- ◆ Retract the leveling system or prepare the air leveling system for travel prior to operating the slide-out.
- ◆ Confirm the house batteries are fully charged.
- ◆ Interior house power must be **ON**.
- ◆ Locate the control switch for the slide-out, usually on the vanity cabinet.

- ◆ Ensure all people, pets and objects are clear of the slide-out room path.
- ◆ Press and hold the switch in the **IN** position. The slide-out room will move slowly in. The motor will change tone when the slide-out is fully retracted.
- ◆ Release the switch.

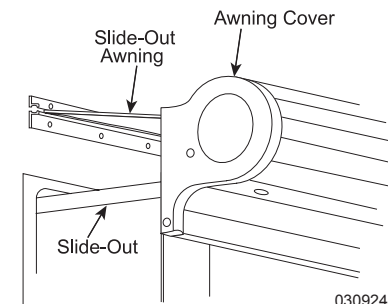

CAUTION:

Continuous operation of the slide-out can drain the battery and damage the slide-out motor by overheating. Never move the motorhome without having the slide-out retracted.

AWNINGS Slide-out Cover

The slide-out cover automatically reacts to slide-out direction. A fixed edge of the slide-out cover is installed into an awning rail, mounted just above the slide-out. A spring-loaded roller with special brackets mounts to the slide-out. In a hard rain, the cover helps prevent water from penetrating the seal of the slide-out. The slide-out cover will automatically reach full extension when the slide-out room is fully extended.

The slide-out cover automatically rolls up into the travel position when the slide-out room is completely retracted.

NOTE:

When retracting the slide-out, stop the room approximately halfway. Confirm that the fabric is properly rolling before fully retracting the slide-out.

CAUTION:

The slide room and slide-out awning should be retracted before heavy wind, rain or snow to prevent damage to the awning or motorhome. Wind can drive rain under the slide-out awning and into the motorhome.

CAUTION:

At least five feet of clearance is needed between the side of the motorhome and any objects, such as trees or fences, to allow the slide room and slid-out awning to fully extend.

CAUTION:

Rain water can pool on the slide-out awning. The added weight will cause the awning to sag. Upon retracting the room, material can become caught in between the top of slide room and the opening in the motorhome. It will be necessary to retract the room in small increments and allow the water time to run off.

Entry Door Awning - Girard Automatic (Optional)

The Girard door awning uses 120 Volt AC to operate.

To Extend or Retract the Awning:

- ◆ Hook to shore power, start the generator or turn on the inverter.
- ◆ Press and hold the “Door Awning” switch on the awning switch panel. Awning travel may be stopped and reversed at any time by releasing and then pressing and holding the awning switch.



060297b

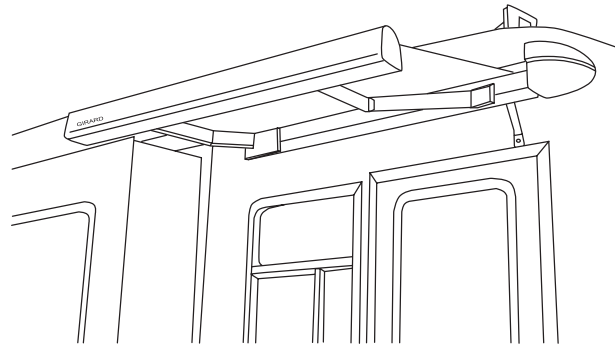

Optional Entry Door Awning Extended

031034c

Window Awning (Optional)

The window awning uses 120 Volt AC to operate.

To Extend or Retract the Awning:

- ◆ Hook to shore power, start the generator or turn on the inverter.
- ◆ Press and hold the appropriate window awning switch located on the awning switch panel. Awning travel may be reversed at any time by releasing and then pressing and holding the awning switch.

Patio Awning - Girard

The Girard Lateral Arm Awning extends and retracts by using the remote.

Features:

- ◆ Retractable arms use twin cables for increased fabric tension.
- ◆ All aluminum hardware is powder coated to give long-lasting protection for both housing and mechanical parts.
- ◆ 100% acrylic fabric is weatherproof, permeable to air and resistant to mildew, rotting and fading.
- ◆ Motorized operation including a manual crank override for emergency retract.
- ◆ The wind sensor automatically retracts the awning during windy conditions.
- ◆ The electric motor is housed in the roller tube where it is protected from the elements and view.

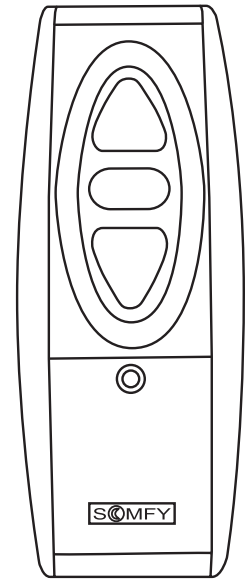

Girard Awning 060240 Remote.

Extending the Awning:

The awning operates from 120 Volts AC. Hook to shore power, start the generator or turn on the inverter. The ignition must be off for the awning to operate. The awning requires 10' of lateral side clearance. Press the top button on the remote to extend. Awning travel can be stopped at any time by pressing the **middle** button on the remote.

CAUTION:

It is strongly recommended to extend the awning full distance for maximum strength. To prevent damage, retract the awning before gusting winds or inclement weather. Rainwater can quickly collect (pool) on the canvas and overload awning hardware, resulting in damage.

NOTE:

The awning motor is not designed for continuous use. In the event the motor is used to excess, it will automatically shut off and remain inoperative until the circuit breaker inside the motor cools down and automatically resets. Awning run time should not exceed four to five minutes per hour. If the breaker trips, it will automatically reset in 30 minutes to one hour depending on ambient temperature.

After Extending the Awning:

After the awning has fully extended, no further setup or hardware installation is necessary. The 120 Volt AC power supply must remain on for the awning to automatically retract in excess wind. The awning is equipped with a remote mounted anemometer (wind speed sensor) that detects wind speed and automatically retracts

(requires 120 Volt AC) the awning when wind speed exceed a preset speed for more than a few seconds. If the wind speed sensor retracts the awning, leave the awning retracted until wind subsides to prevent possible awning damage. Retract the awning in inclement weather conditions, or when leaving the motorhome unattended.

Retracting the Awning:

- ◆ Clear away any leaves, pine needles or other debris by lightly tapping the awning from underneath using a broom handle or other instrument that will not harm the fabric.
- ◆ Press the bottom button on the remote to retract the awning when at full extension. Awning travel can be stopped by pressing the remote middle button.

NOTE:

If the fabric was wet when the awning was retracted, extend the awning at the soonest opportunity to allow the fabric to thoroughly dry.

Emergency Procedure:

If the awning does not operate:

- ◆ Check to make sure the 120 Volt AC is on by hooking to shore power, starting the generator or turning on the inverter.
- ◆ Check the circuit breaker in the 120 Volt AC breaker panel.
- ◆ The circuit breaker inside the awning motor may have tripped. Wait 30 minutes to one hour then retry. If the awning still does not respond, the awning can manually retract by using the supplied telescoping crank handle.

INFORMATION:

Follow the instructions for manual awning retraction in the equipment manufacturer's manual.

Wind Sensor Adjustment:

To prevent damage, the awning system utilizes a Wind Sensor that will retract the awning in case of sustained winds. In order for the Wind Sensor to operate, the motorhome must either be hooked to shore power, the generator running or

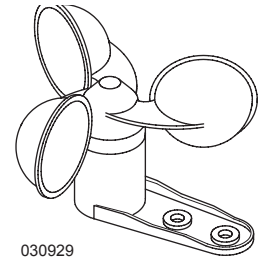

030929

Wind Sensor: Located on the roof of the motorhome.

the inverter turned on. The Wind Sensor will override any switch command. An adjustable potentiometer, located in the awning control box, sets the wind speed necessary to retract the awning. The potentiometer, adjustable between 12 and 31 mph, is preset from the factory at 22 mph. The control box is located in the forward cabinet of the curbside living room overhead. The access panel must be removed to adjust the wind speed sensor.

To Adjust the Sensor:

- ◆ Disconnect or turn off AC power. Turn off the interior house power (12 Volt DC).
- ◆ Unscrew the cover plate screws.
- ◆ Adjust the potentiometer clockwise to increase the amount of wind speed needed to retract the awning.
- ◆ Adjust the potentiometer counterclockwise to decrease the amount of wind speed needed to retract the awning.

CAUTION:

Setting the potentiometer above 25 mph may void the warranty.

When the wind sensor attains the set speed for more than a few seconds, the awning will automatically retract, provided the awning has 120 Volt AC power. The awning will not automatically open when wind speed subsides, but must be opened using the switch.

Tips for Awning Use:

- ◆ Avoid leaving the awning partially extended during inclement conditions. The awning is at the strongest setting when fully extended.
- ◆ If the wind sensor retracts the awning, it is recommend to leave the awning in until winds subside.
- ◆ Awning will not operate with the ignition key in the **ON** position.

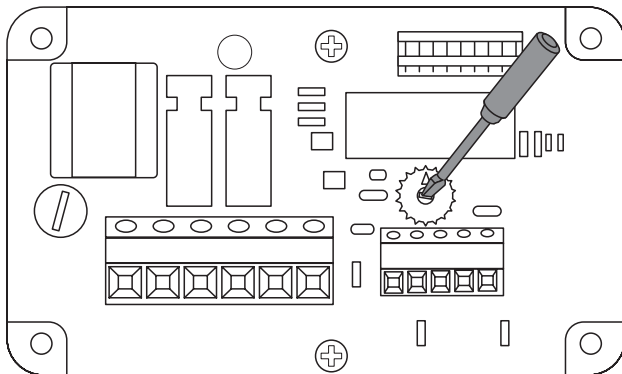

Control Box with cover removed.

030930

Awning Care & Cleaning

On a monthly basis, loosen hardened dirt and remove dust from the awning with a dry, medium bristle brush. Thoroughly rinse both the top and bottom with a garden hose.

A high-quality acrylic fabric cleaner may be used to help maintain appearance. Carefully follow the instructions on cleaning products. Metal surfaces should be cleaned with soapy water and thoroughly rinsed. Allow the awning to thoroughly air dry while extended. Awning maintenance products can be found at RV supply stores.

Carefree Awnings:

Acrylic Awnings - Wash both sides of the awning with a mild soap (i.e., dish soap) and lukewarm water. **DO NOT** use detergents. If necessary, reapply the solution to keep fabric saturated. Rinse the awning thoroughly. Repeat, if necessary, until most of the stains disappear. Contact *Carefree of Colorado* for removal of stubborn stains.

Leaks:

It is normal for slight leakage to occur through the fabric where water is allowed to accumulate. If water drips through the needle holes in the stitching use a commercial seam sealer that is available in canvas and trailer supply stores. Paraffin wax may also be applied to the top of the seams. As the awning “weathers” these holes will normally seal themselves.

Soap or chemical residue can “wet” the fabric so that it appears unable to repel water. Rinse the fabric thoroughly and test to see if it is water repellent after it dries. If leakage continues after washing and thoroughly rinsing, please contact *Carefree of Colorado*.

Girard Awnings:

Mix a solution of mild soap (natural soaps are best) and water. Use a brush to apply the solution. Thoroughly rinse to remove soap. If a liquid detergent is used, a water repellent (such as 303 Hi-Tech Fabric Guard) treatment will have to be applied. For stubborn stain removal contact Girard Systems.

Storm Precautions

The warranty does not cover damage caused by acts of nature; therefore, steps should be taken to prevent damage from occurring due to wind, rain or storms. Retract the awning in inclement weather conditions or when leaving the motorhome unattended. Should the awning need to be retracted while the fabric is wet, extended it as soon as possible to allow it to completely dry.

NOTE:

Water weighs 8.33 pounds per gallon. The awning was not designed to withstand the 500 to 700 pounds of water that could accumulate on the canvas.

FANS

Bathroom Fan

The bathroom fan has three speeds with a **0 (Off)** position. A built in thermostat has an operating range of 22° F to 123° F, based on inside ambient air temperature. The blue zone on the thermostat is cool; the red zone indicates heat. The fan starts automatically when the lid opens approximately two inches during normal operation.

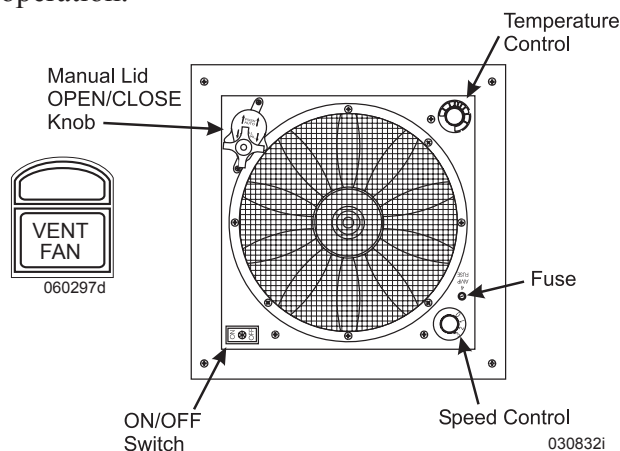

Automatic Operation:

Leave fan in **AUTO** position for normal operation. Turn **FAN** switch **ON** at sink cabinet; the lid will open and the fan will start. The **AUTO** mode will not operate with the fan speed switch in the **0** position. Turn **FAN** switch **OFF** at sink cabinet to lower vent lid and stop fan.

Manual Operation:

To adjust vent lid to different opening positions pull **DOWN** on the manual lid knob, turn knob counterclockwise to lower the lid. Return fan to **AUTO** position by pushing **IN** on the knob.

Rain Sensor Operation:

If the built in rain sensor gets wet, the dome will automatically close and the fan will shut off. After the sensor dries, the dome will reopen and the fan will start. To avoid automatic restart, turn fan speed to “0” after the rain sensor closes the dome.

NOTE:

The fan cover will not operate in the **AUTO** position if the speed switch is set on “0.”

CAUTION:

It is recommended to travel with the vents closed. High winds and vibration can damage the Plexiglass® dome.

Tips for Fan Operation:

- ◆ To keep condensation from accumulating, operate the fans. Condensation occurs naturally from fluctuations in interior and exterior temperatures, humidity and dew point changes, steam from cooking or boiling large amounts of water on the cooktop. Shower use is another source of condensation.
- ◆ If the fan fails to operate, check for a blown fuse either in the domestic fuse panel or the 4 Amp fuse on the fan.
- ◆ To remove the screen, loosen the eight screws holding the screen in place. Use a non-abrasive soap and water to clean and reinstall.

- ◆ Slightly open windows on the shaded side of the motorhome to create the most airflow, especially on hot, sunny days. Direct airflow by slightly opening selected windows. Maximum airflow is achieved between an open window and the Fantastic Vent.

NOTE:

DO NOT leave the fan switch in the active mode while the motorhome is stored or unattended for extended periods. High winds, unusual conditions or obstructions may prevent the fan cover from fully closing, resulting in leakage and serious damage.

Exhaust Fan

A wall thermostat controls the galley exhaust fan using House 12 Volt DC to operate.

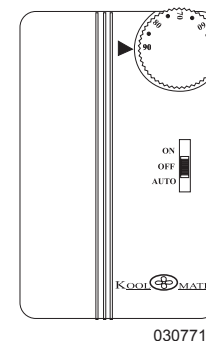

To Operate the Fan:

- ◆ Remove the ceiling grill cover.
- ◆ Open the grill damper.
- ◆ Select one of three fan speeds using the round knob on the grill.
- ◆ Set the thermostat to **ON** for continuous airflow or set the thermostat to **AUTO** and set the desired air temperature for thermostatically controlled airflow.
- ◆ To turn off the fan, set the thermostat to **OFF**. Close the grill damper and install the ceiling grill cover.

NOTE:
Close the grill damper before installing the grill cover. Failure to close the damper may result in the cover blowing off while the motorhome is in motion.

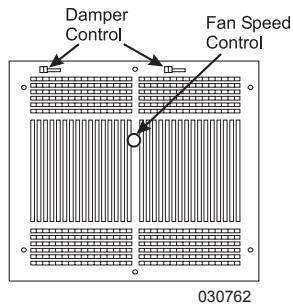

030762

To Operate the Visors:

- ◆ Use the **Battery Cut-off** switch to turn **ON** the interior house power.
- ◆ Push the switch **down** to lower the desired Sunvisor.
- ◆ Push the switch **up** to raise the Sunvisor.

NOTE:
DO NOT attempt to move or drive the motorhome with any window view obstructed.

Bedroom Ceiling Fan (Optional)

A bi-directional, 12 Volt DC powered ceiling fan is located in the bedroom. Fan operation is controlled by a switch located next to the bed. Periodic maintenance consists of cleaning the blades with a soft cloth towel or a vacuum to remove dust build up.

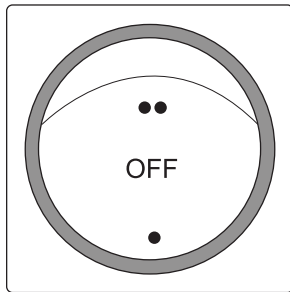

Bedroom ceiling fan switch.
031271

CAUTION:
Fan blades are not enclosed. Use caution not to enter into fan path when on. Serious injury can occur.

POWER SUNVISOR

The windshield visors are 12 Volt DC operating from the house batteries. One visor assembly is used for the driver and another for the passenger.

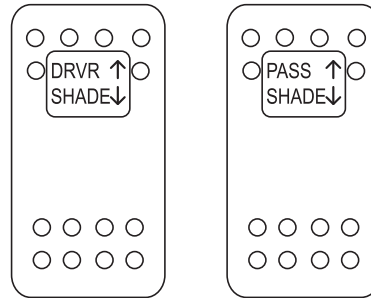

080306

BLINDS COCKPIT (OPTIONAL)

The cockpit blinds are 12 Volt DC operating from the house batteries. One blind assembly is used for each window located in the cockpit area.

To Operate the Blind:

- ◆ The interior house power must be on.
- ◆ Push the switch **DOWN** to lower the desired blind.
- ◆ Push the switch **UP** to raise any blind.

NOTE:
DO NOT attempt to move or drive the motorhome with any blind in the lowered position.

DOOR - SLIDING

The sliding pocket door uses two rollers at the top of each door. During the life of the motorhome, the sliding door may require adjustment. Locate the small wrench and turn the adjusting screw upward or downward.

If, for any reason, the pocket door needs to be removed, locate the portion that is secured to the top of the pocket door and rotate the small lever outward to release the latches.

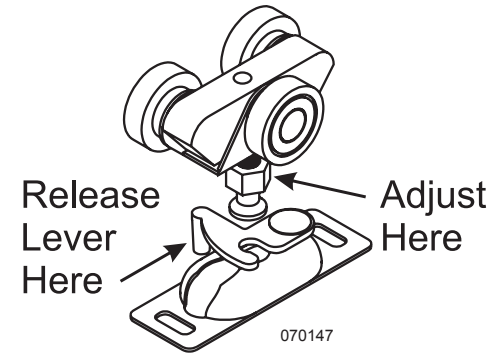

070147

LUBE:
The pocket door rollers should be lubed with just a small drop of oil once a year to help increase the life of the rollers and improve the sliding of the door.

PRIVACY DRAPE- ELECTRIC (OPTIONAL)

A single drapery motor is mounted on the track railing. Cleaning the rail and drive wheel with Windex® or Fantastic® is recommended every two months.

NOTE:

DO NOT use any lubrication on the motor or the rail. Interior treatment such as Armor-all® should not contact the rail. Keep the rail and drive wheel clean and dry.

To Operate the Drapes:

- ◆ Use the **Battery Cut-off** switch to turn **ON** the interior house power.
- ◆ Drapes are incorporated in Multiplex circuitry. Press and hold switch to operate drapes.

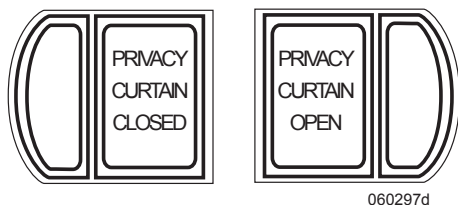

060297d

SEAT CONTROLS

The Pilot and Co-pilot seats are adjustable to provide maximum comfort. Seats must be locked in the forward facing direction while traveling. Each seat is operated by a 20 Amp fuse located in the front run box.

NOTE:

The seats operate from 12 Volt DC house power. The ignition must be on to operate the seat heater.

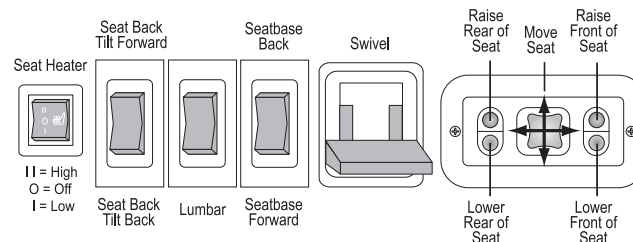
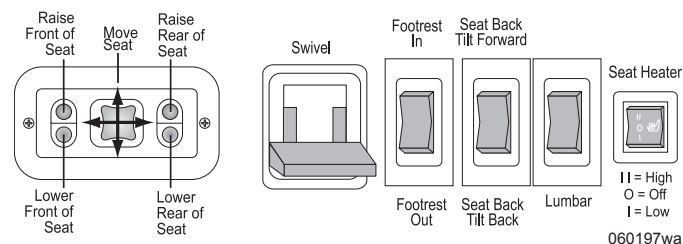
Pilot**Co-Pilot**

060197wa

Swivel Seats**Swivel Seat Operation:**

- ◆ To swivel, lift up the lever located on the side control panel.
- ◆ The passenger seat swivels all the way around when the slide-out is extended.
- ◆ When rotating the driver seat, put the steering wheel in the upright position.
- ◆ Move the seat forward, then pull the swivel lever up and rotate to the desired position.

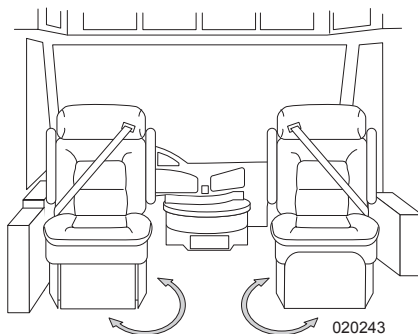

020243

WARNING:

Seats must be locked in the forward facing position while the motorhome is in transit.

NOTE:

After either seat is rotated 180°, it must be rotated back in the opposite direction. The 12 Volt wiring in the seat may disconnect if rotated 360°.

SOFA BED CONVERSION

The sofa will convert easily into a bed. The sofa comes equipped with safety belts to use during travel.

Sofa to Sleeper:

- ◆ Lift up from the center of sofa, just below the seat cushions, to form a “V” shape with the seat base and back rest.
- ◆ Push down on seat base, then pull out until the seat base and backrest are flat.
- ◆ Fold seat belts out of the way.

Sleeper to Sofa:

- ◆ Lift up the seat base and pull up the backrest until they are in a “V” position.
- ◆ Push down on seat base.

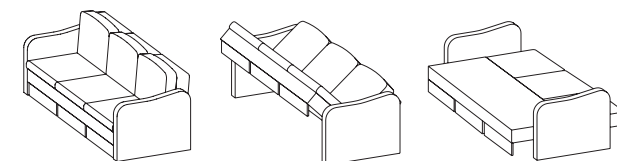

020222

AIR MATTRESS BED (OPTIONAL)

The air mattress pump is located in the bed storage compartment and is plugged into a 120 Volt AC outlet. **Two remotes are used to adjust the firmness setting of each side of the mattress.** Only one side of the mattress may be adjusted at a time. **When one remote is being used, the other remote is inoperative.**

To Operate Mattress:

There are two modes that can be used to adjust the mattress firmness: Manual (1) mode and the Pressure Sensitive (2) mode. The air mattress reads body weight to make proper adjustments and requires someone to be on the mattress when adjusting firmness settings in both the Manual and Pressure Sensitive modes.

To Select Modes:

Hold the **MODE** button down until the remote beeps, then release. The display will read 1. Use the + and - buttons to alternate between Manual and Pressure Sensitive modes. To enter the mode that is selected (1 or 2) hold down the **MODE** button again until the remote beeps. To return to mode select, at any time, press and hold the **MODE** button down until the remote beeps.

When in Manual Mode (1):

Press and hold the + button to increase mattress firmness or press and hold the - button to reduce mattress firmness. After adjusting the mattress the current firmness will be displayed on the remote for a few seconds.

When in Pressure Sensitive Mode (2):

The firmness setting will show on the display and can be adjusted in 1% increments by pressing the + and - buttons.

To Store a Firmness Setting:

After adjusting the mattress firmness in either the Manual (1) or Pressure Sensitive (2) mode press and hold the blue **MEMORY** button until the remote beeps. The firmness setting is stored. The firmness can be adjusted and then returned to the stored setting by pressing the **MEMORY** button. Holding the **MEMORY** button down until it beeps will change the stored position to the current mattress firmness.

NOTE:

This system is designed to use the back pressure of a person's weight. Changes to firmness should be made while lying on the mattress.

Instant Fill Feature:

The instant fill feature works in either the **MANUAL** or the **PRESSURE SENSITIVE** mode. Press the **FULL** button on the remote and the mattress will inflate to 100% capacity. The instant fill works with or without someone on the mattress.

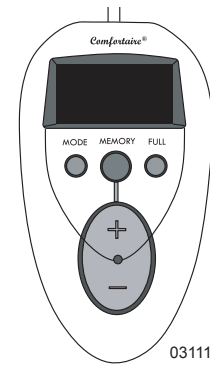

031117
Air Mattress Remote

Cleaning and Maintenance:

- ◆ Check air filter at back of pump monthly. Rinse with water to clean and let dry before installing.
- ◆ Over time normal settling and impressions in cover will occur. Only the cover quilting is affected. Steam clean only, allow mattress cover to dry thoroughly. **DO NOT** dry clean.

Troubleshooting

Slow Leak: Check fittings on front of pump and connections to mattress. If the hose leaks from the outlet side of pump, remove clamp, cut hose 1" and re-install hose and hose clamp.

If problem continues, cut hose from air pump nozzle and install hose plugs (located in the mattress cover) in hose ends. If air holds in the mattress the problem may be the pump. If air does not hold, then the problem is most likely the mattress. Call *Comfortaire* at **1-800-759-0594**.

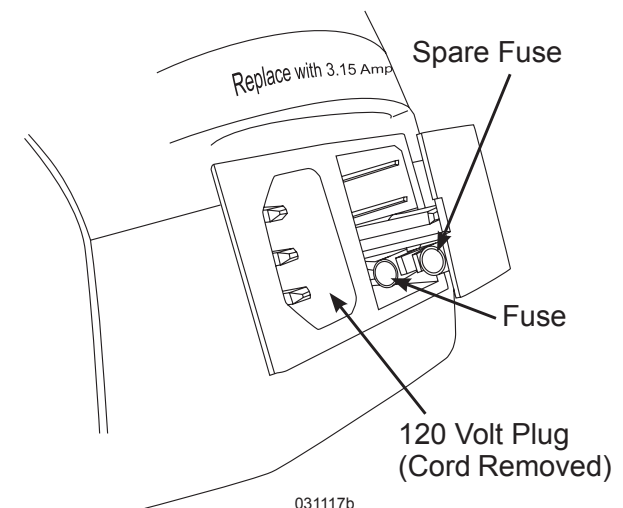

031117b

Pump will not operate:

- ◆ For the pump to operate, the motorhome must be plugged in, the generator running or the inverter engaged. Ensure the pump in the bed storage compartment is plugged in.
- ◆ Check the fuse on the pump. Use a key or a small screwdriver to open the fuse compartment and inspect the back fuse. If a fuse is bad, replace it with the spare located in the holder. When the fuse holder is pushed in, the fuse is installed.
- ◆ If the motorhome has power but the remote does not display, check phone line connections at remotes and at the pump.

Pump operates but pressure does not change:

Check for kinks in the hose or a visible obstruction between the pump and mattress.

NOTE:

DO NOT disassemble pump. Internal components can be damaged and warranty will be voided.

SUPER SLIDE (OPTIONAL)

The Kwikkee Super Slide is an option that is available for use in the storage compartment bays of the motorhome. The super slide allows for the pay load to slide outward for easier access.

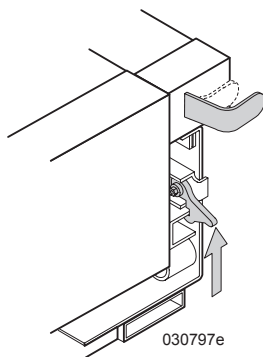

- ◆ The motorhome must be level before opening.
- ◆ There are two latch releases: lift and hold up to release one, pull outward while pulling on the super slide to release the other.
- ◆ Maximum weight capacity is 1,000 lbs. Never exceed this amount.

WARNING:

The motorhome must be level when sliding the drawer out of the bay compartment. If the motorhome is not level, the drawer can slide out abruptly and cause bodily harm.

POWER SUPER SLIDE (OPTIONAL)

The power storage tray (in full pass-through bays only) can be operated from the momentary switch located in the curb side bay, the Power Slide remote or the manual override if power is lost. Safety cut out switches on the roadside and curbside prevent tray operation when the cargo bay doors are closed.

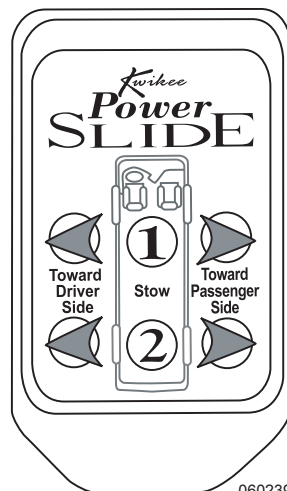

Power Slide Remote

Using the Remote:

- ◆ Press the left or right arrows, adjacent to the tray number to be moved, to slide tray out.
- ◆ To stow tray, press the stow button (1 or 2).
- ◆ If the tray is out on the roadside, press the curbside button (right arrow) to return the tray to the stow position.
- ◆ To stop tray operation when the tray is sliding out, press the opposite arrow button.

Troubleshooting:

- ◆ Power comes from a 40 Amp mini-breaker in the Rear Run Box labeled Bay Slide.
- ◆ Ensure the House Battery Disconnect in the battery compartment is **ON**.
- ◆ Ensure interior house power is **ON**.
- ◆ Check safety switch on hinged side of cargo door opening to see if it is out of adjustment. With the door open the switch should provide a ground through the metal contacts on the back of the switch.

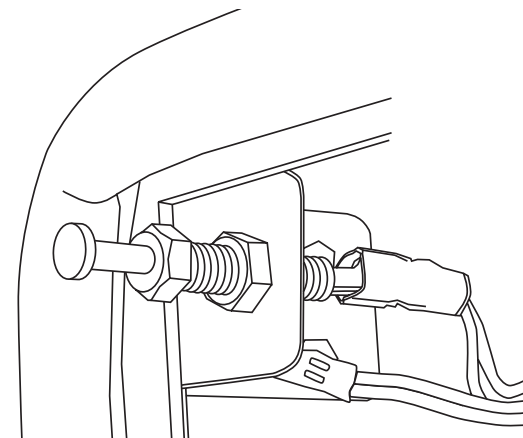

Power Slide Safety Switch

Manual Override:

If battery power is lost or if there is an electrical problem, the tray can be manually operated. Lift the manual release lever on the power module. Push tray in and return arm to lock position.

NOTE:

**Maximum weight capacity is 800 lbs.
Never exceed this amount.**

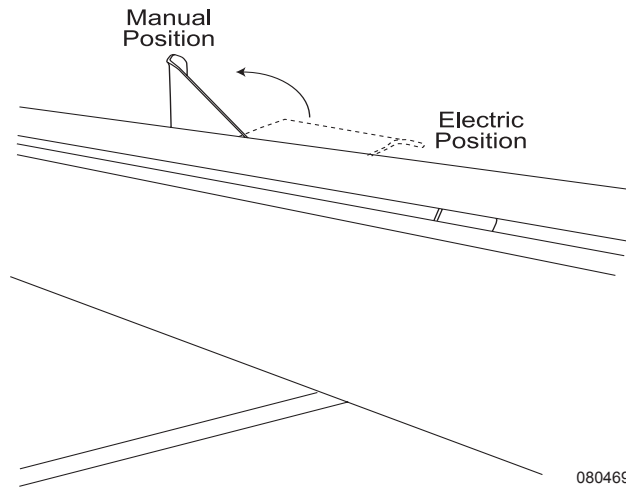
**LADDER - REAR**

The rear ladder allows access to the roof. Care should be used when climbing the ladder. Access to the roof should be limited to cleaning and sealing purposes only. Stow the lower portion of the ladder in the cargo bay during travel.

NOTE:

Maximum weight capacity for the ladder is 300 lbs.

CITIZENS BAND (CB) RADIO - PREP

A two pin connector labeled Citizens Band Radio is located behind the dash panel, along with the CB Antenna coax, which is routed to the roof mounted antenna. The red wire is + 12 Volt DC (positive) and has a two amp fuse in the front distribution panel. The white wire is connected to the frame (ground).

CITIZEN BAND (CB) RADIO (OPTIONAL)

The CB radio is a low-powered transmitting device used for two-way, short-distance communications. The CB can be a very useful tool for emergency weather condition information and potential road hazards reported by other CB operators.

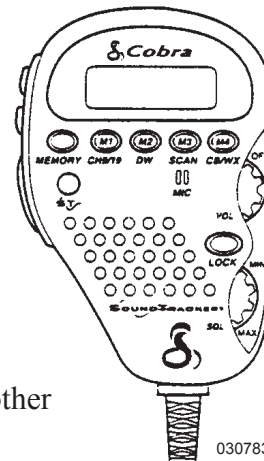

CB Radio Handset

Handset:

- ◆ Volume/On/Off control has no effect on radio transmission.
- ◆ Squelch control is first turned up to a point where static or background noise can be heard then reduced to a point where the static disappears.
- ◆ The Channel Selector is used to select channels (1-40) by pressing the Channel Up/Down Tuning buttons.

- ◆ When the Microphone button is pressed, the CB radio switches from a listening device to a transmitter. Anything spoken into the microphone is transmitted over the airway of the channel selected. Press the button to talk and release the button to receive a reply.

Emergency Communication:

- ◆ Set the CB radio to Channel 9.
- ◆ Request a React base (if available) to respond by saying “Break Channel 9 for a React base” and provide the CB Distress Data (called “CLIP”) repeatedly so the nearest monitor may be of assistance:

Call Sign - Identify yourself and vehicle.

Location - Be exact.

Injuries - How many? What type? Are persons trapped?

Problem - Give details and be specific about the assistance needed.

NOTE:

Channel 9 is for emergency use only.

Following rules of use:

Limit communication to five minutes at a time. Give others a chance to use the channel. **DO NOT** use illegally amplified transmitter power or illegally high antennas or promote illegal activities. **DO NOT** transmit profanity or music over the airway. **DO NOT** use the CB to sell merchandise or a professional service.

Troubleshooting:

- ◆ **Limited Range:** Weather conditions, environment, terrain, trees, other vehicles, and/or the power of the radio and its antenna, and matching of the Standing Wave Ratio (SWR) setting affect CB radio range. See OEM (Original Equipment Manufacturer) manual to adjust SWR.
- ◆ **No Power:** Check 3 Amp fuse in Front Run Box.

GPS NAVIGATION

The GPS Mobile Navigation system provides 2-D and 3-D map views, instant re-routing and voice prompted turn-by-turn instructions. The system includes a GPS antenna, a DVD ROM player, touch screen monitor and a single DVD to provide maps for the entire continental US and Canada.

INFORMATION:

Complete information and instruction are found in the OEM instruction manual.

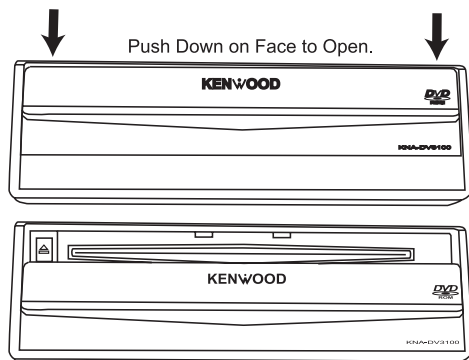

Located under center dash console. 031052c

Perform the following instruction only when the motorhome is parked:

- ◆ Press the **PWR** button to turn on the Navigation monitor.
- ◆ Insert the map disk in the navigation CD unit.
- ◆ Press **V.SEL** repeatedly until **NAV** is displayed on the screen.
- ◆ When the ignition is switched on, the opening screen will appear on the monitor. The **Caution** Screen will follow.
- ◆ The monitor is a touch screen display. Press the **Agree** label to enable the **Current Position** screen.
- ◆ Press the **MENU** label to enable the main **NAVIGATION MENU**.

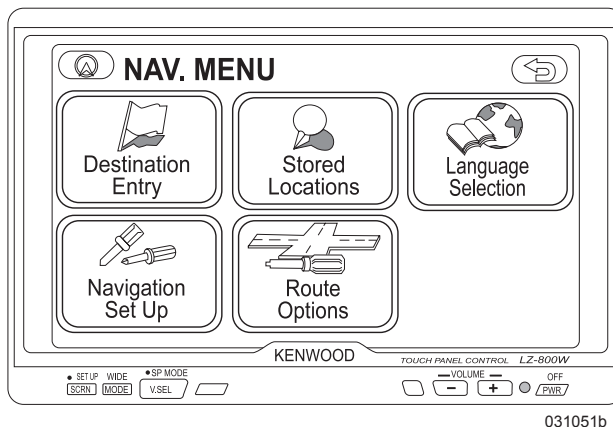
**SATELLITE RADIO (OPTIONAL)**

The satellite radio is a digital signal decoder and tuner. Signals are transmitted from a ground station to satellites orbiting over the continental United States. The satellite then transmits the

signal to an antenna in the motorhome. The radio receiver decodes the transmission and plays the selected channel within that transmission. Signals are also transmitted to ground repeaters for listeners in urban areas where the satellite signal can be interrupted.

NOTE:

Depending upon selected options, **Sirius®** or **XM Radio** may be the satellite provider. For information regarding subscriptions and service coverage areas, contact the appropriate provider for your system.

Sirius® Radio
1-888-539-7474
www.siriusradio.com

XM Radio
1-800-XMRADIO (1-800-967-2346)
www.xmradio.com

INFORMATION:

For detailed information, account activation and operating instructions on the satellite radio, refer to the manufacturer's manual located in the Owner's Information File box.

ALADDIN™ SYSTEM

The Aladdin™ system is designed to monitor various chassis and house systems, providing up to date and accurate information. This allows the operator to make informed decisions regarding operations of the motorhome.

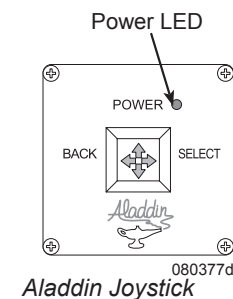

Chassis information comes from the engine and transmission electronics. House information is obtained from a number of sensor modules distributed throughout the motorhome.

The Aladdin™ system also automatically selects one of a number of cameras that can be used to aid the driver. When the system is turned ON, placing the transmission in reverse will cause the backup camera to be selected. For units equipped with See Vision side cameras, activating a turn signal will select the corresponding side view camera.

Joystick Module:

The Joystick Module is the operator interface to the Aladdin™ system through the monitor display. Multiple joystick modules may be attached to the Aladdin™. Each joystick module allows the operator to control cursor movements. Push the joystick to the right to enter a menu item, push the joystick left to return to the previous menu. Push the joystick up or down to scroll through or change information. An LED provides system-on power indication. When the joystick is moved, the LED turns off briefly (“blinks”), indicating that the joystick command has been transferred to the Aladdin™ controlled module. During normal operation, the LED also blinks approximately every four seconds.

Operations

The Aladdin™ is turned on either with the motorhome ignition switch or the joystick. The Aladdin™ will power down when ignition is turned off, unless the operator selects the Aladdin™ to remain on.

Main Menu:

When the Aladdin™ is powered up, the main menu appears. The operator can choose any item by pressing the joystick up or down. An arrow indicates the current menu item. Press the joystick right to select that menu item. Press the joystick left to return to the previous screen.

NOTE:

Interior 12 Volt DC house power must be on for the Aladdin™ screen to be displayed.

MAIN MENU	
	ENGINE/TRANS STATUS
	COACH ELECTRICAL STATUS
	COACH TANK/MISC STATUS
	TRIP METER SELECTION
	TIME/ALARM FUNCTIONS
	SELECT VIDEO SOURCE
>	SYSTEM OPTIONS
	POWER DOWN ALADDIN

Camera Select (with optional See Vision):

The Aladdin™ operator can manually select one of the four video cameras that are attached to the Aladdin™. When the sub menu item is first selected after initial power-up, the Aladdin™ will display the video from each camera sequentially, changing camera view once every six seconds. A specific camera can be manually selected by moving the joystick up or down.

NOTE:

The backup camera is automatically selected when the transmission is placed in reverse and the side cameras are activated by the turn signals. If both turn signals are active (hazard lights) then the backup camera will be selected.

If a turn signal is activated while in reverse, the side camera will override the backup camera.

Engine/Trans Status:

Provides the operator with a single screen display of current available engine and transmission data. Compass heading and time are displayed on each screen.

SW 225	11:55 AM
ENGINE	TRANS
0.0 MPH	57 F TEMP
5 RPM	
59 F TEMP	XX Gear Sel
0 PCT LOAD	XX Gear Att
0 PSI OIL	BATTERY
0.5 PSI BOOST	12.0 VDC
0.0 MPG	
XX.X Cruise Off	
	CAMERA >

Move the joystick to the right to enter the back up camera display and press right again to show the Engine/Trans Status screen. An enlarged engine and transmission screen will display, showing only four parameters at a time, with five screens available. The screens are automatically scanned approximately every six seconds.

Move the joystick up or down to manually move through the screens and disable automatic scanning. Move the joystick right to resume automatic scanning. Move the joystick left to return to the previous all-in-one screen. A left/back from this original status screen will return to the backup camera and another left/back will return to the main menu.

SW 225	11:56 AM
ROAD SPEED	0.0 MPH
ENGINE SPEED	5 RPM
ENGINE COOLANT TEMP	59 F
TRANS OIL TEMP	58 F

Coach Tank/Mis Status:

The **COACH TANK/MISC STATUS** screen reads fresh, grey and black tank percentage full and corresponding gallons, LP-Gas tank percentage full. Basement and outside temperatures as well as compass heading are displayed.

COACH TANK/MISC STATUS		
	PCT	GAL
FRESH TANK	XXXX	XXXXX
GRAY TANK	XXXX	XXXXX
BLACK TANK	XXXX	XXXXX
LP TANK	XXXX	XXXXX
BASEMENT TEMP	XXXX	F
OUTSIDE TEMP	XXXX	F
COMP HEADING	XX	XXX

Coach Electrical Status:

The **COACH ELECTRICAL STATUS** screen will provide a display of AC Leg 1 and Leg 2 Volts, Amps and Frequency, House Battery Volts and Amps, and Solar Panel Voltage, Amps, and Electrical Status selected.

COACH ELECTRICAL STATUS			
	VAC	AMP	FRQ
AC LEG1	125	0.0	60
AC LEG2	125	19.0	60
SHORE POWER SELECTED			
	VDC	AMP	
SOLAR	1.0	0.0	
HOUSE BAT	12.2	0	

Time and Alarm Functions:

The time and alarm menu allows access to view the current time or to set the date and time. From the Main Menu move the joystick down to select Time/Alarm Functions and move the joystick to the right. From the Time and Alarm Functions menu select View Current Time or Set Date and Time.

MAIN MENU	
	ENGINE/TRANS STATUS
	COACH ELECTRICAL STATUS
	COACH TANK/MISC STATUS
	TRIP METER SELECTION
>	TIME/ALARM FUNCTIONS
	SELECT VIDEO SOURCE
	SYSTEM OPTIONS
	POWER DOWN ALADDIN

Set Date and Time screen allows setting the current time and date. Joystick left or right selects the various digits. Joystick Up and Down changes the value.

TIME AND ALARM FUNCTION	
	VIEW CURRENT TIME
>	SET DATE AND TIME
	SET ALARM CLOCK
	ALARM CLOCK ON/OFF
	SET COMPARE ALARM
	MAINTENANCE SCHEDULER
	ALARM CLOCK SOUND: 11
	ALARM SOUND: 3

SET DATE AND TIME	
	7:19:52 AM 08/08/01
	DAY OF THE WEEK: WED

View Current Time:

View Current Time screen is a large display of information entered in the Set Date and Time screen. There are no changes which can be made to this screen.

```

TIME AND ALARM FUNCTION
> VIEW CURRENT TIME
  SET DATE AND TIME
  SET ALARM CLOCK
  ALARM CLOCK ON/OFF
  SET COMPARE ALARM
  MAINTENANCE SCHEDULER
  ALARM CLOCK SOUND: 11
  ALARM SOUND:      3
  
```

```

CURRENT TIME
7:19:52 AM
THU xx/xx/xx
  
```

System Options

The **SYSTEM OPTIONS** screen provides the operator with a submenu for Aladdin™ functions that are less frequently used, and includes screen appearance adjust. Only service personnel should access **SYSTEM SETUP**. To assist the service technician in troubleshooting system problems, the **SENSOR MODE** may be used.

```

SYSTEM OPTIONS
ALADDIN MODEL 431-06 VER 3.03
JOYSTICK F / W VERSION 1.02

SCREEN COLOR: 0
TEXT COLOR: 1
SENSOR MODE: NORMAL
SYSTEM SETUP
COMPASS CALIBRATION
  
```

Screen and text colors are selected by first selecting the menu item using joystick up and down, then successive joystick rights will sequence through the seven available colors. Colors selected immediately display to allow the operator to set colors for personal preference. Selected colors are stored and remain in effect until changed, even when the Aladdin™ is powered down.

The usual **SENSOR MODE** is **NORMAL**; additional options are **RAW** and **VERSION**. **RAW** mode causes the sensor modules to display raw, unmodified/calibrated data from their sensors, and might be used by technicians troubleshooting the system. **VERSION** mode causes the sensor modules to display internal software version numbers.

Compass calibration is used to match the compass module to the motorhome, and may be performed as needed.

System Setup:

The **SYSTEM SETUP** screen contains menu items for setting up the sensor modules on the motorhome.

NOTE:

Menu is protected with a maintenance code to prevent accidental calibration. The maintenance code must be entered correctly before proceeding to the SYSTEM SETUP screen.

```

SYSTEM SETUP MAINT CODE

ENTER CODE:

0000
  
```

020195E

```

SYSTEM SETUP

SET TANK CAPACITIES
TANK CALIBRATION
ELECTRICAL CALIBRATION
  
```

020214C

Compass Calibration

The **COMPASS CALIBRATION** system allows the owner to match the motorhome to the Temperature and Compass Module. The compass will compensate for the metal construction within the motorhome and increase accuracy. Entering a declination will allow for true North or magnetic North headings.

COMPASS CALIBRATION

> DECLINATION +xx DEG
START CALIBRATION

START CALIBRATION AND THEN DRIVE COACH IN ONE OR MORE COMPLETE CIRCLES TO ENSURE COMPASS ACCURACY. SELECT STOP CALIBRATION TO END.

Calibration is accomplished by selecting **START CALIBRATION**, then driving in a full 360-degree circle. At the end of driving this loop, select **STOP CALIBRATION**. A successful calibration will cause a “Calibration Successful” message to display. A calibration that fails will display “Calibration Fail” along with a failure code.

NOTE:

Other Aladdin™ functions and screens are discussed in respective sections of this manual.

Power Down Aladdin:

Select **POWER DOWN ALADDIN** to enter Low Power mode and turn off sensor modules. Low Power mode is cancelled when any joystick module is touched.

Turning off the ignition will cause the Aladdin™ to power down. A ten-second countdown is performed prior to power down. Joystick action will abort this countdown and the Aladdin™ will remain on. The Aladdin™ can be manually powered down when desired by selecting the

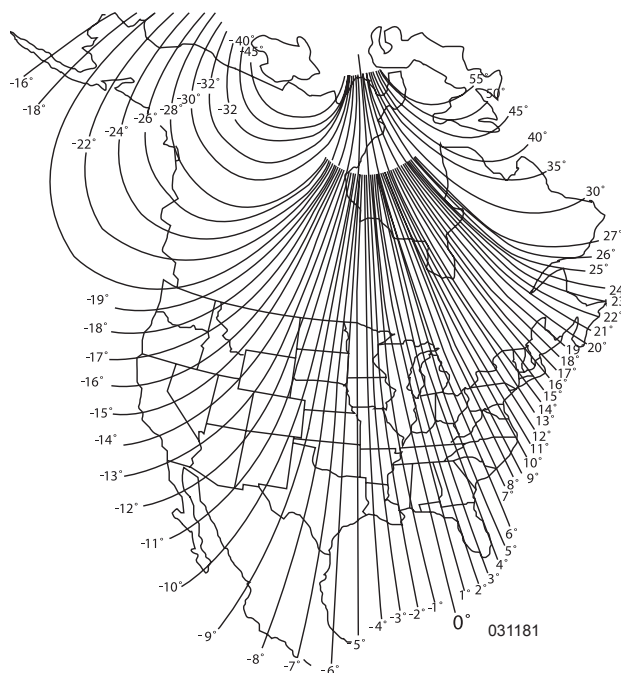

POWER DOWN ALADDIN. If the joystick is not touched before the countdown, and the Aladdin™ has powered down, the joystick touch will cause the Aladdin™ to power back up.

TV & ENTERTAINMENT COMPONENTS

The following paragraphs will discuss the operations and various components that make up the entertainment center.

INFORMATION:

It is recommended to become familiar with individual components. Refer to the respective manual for detailed instructions on operating individual components.

NOTE:

All components of the entertainment system require 120 Volts AC to operate. Hook to shore power, start the generator or turn on the inverter. The satellite system requires 12 Volts DC to operate. Turn on the interior house power using the battery cut-off switch.

Television (Front) Lockout Feature

The ignition switch controls the outlet for the front TV, allowing the front TV to be operated only while the vehicle is at rest. Viewing time of the front TV from the inverter depends on state of charge of the house batteries and any additional 12 Volt DC lighting being used.

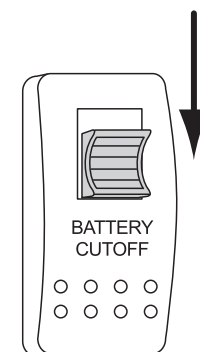

Release Lock 080375

Connections - Cable TV, Computer & Phone

The motorhome is equipped with cable TV and phone hook-ups, located in the electrical service center. For convenience, the auxiliary outlet is located at the co-pilot seat.

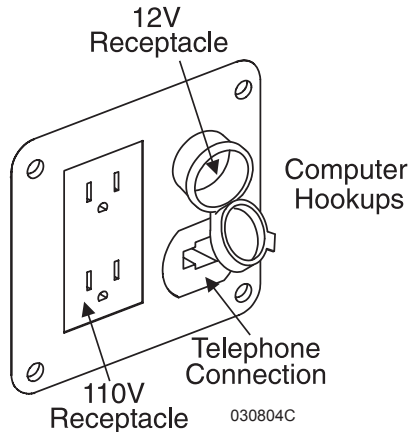

Television Inputs

The televisions have different inputs, such as regular TV reception, satellite dish, DVD/VHS player or the home theater system. The TV tuner interfaces these different input signals from the various components to the televisions.

INPUT MENU	SHARP 20"	SHARP 32"	SHARP 37"
TV	TV Tuner	TV Tuner	TV Tuner
INPUT 1	DVD/VCR	Not Used	NA
INPUT 2	NA	DVD	DVD/VCR
INPUT 3	NA	NA	NA
INPUT 4	NA	Satellite	Satellite
INPUT 5	NA	NA	NA
CARD	NA	NA	Front PC Card

Front TV Input Menu

Television - Ceiling Mounted (Optional)

The LCD television is mounted to an assembly that will stow the television into the ceiling during travel. The “hide-a-way” system uses a 120 Volt AC motor to lower and raise the television. A 12 Volt DC ignition safety lock prevents the television from lowering during travel.

NOTE:

The ignition must be off to raise or lower the TV.

To Lower or Raise the Television:

1. Turn on the interior house power using the battery cut-off switch.
2. Hook to shore power, start the generator or turn on the inverter.
3. To Lower: Push and hold the TV down switch. There will be a short delay. Release the switch when fully lowered.
4. To Raise: Push and hold the TV up switch until fully raised.

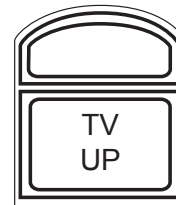

0602297d

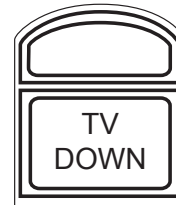

0602297d

Antenna Boost

The antenna boost switch will select between the roof antenna or shore cable.

To Watch TV Using Roof Antenna:

With the button in the ON position, the input to the TV is set to roof antenna and the LED will illuminate.

To Watch TV Using Shore Cable:

With the button in the OFF position, the input to the TV will be set to shore cable and the LED will be off.

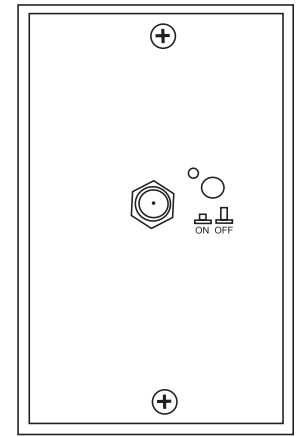

030989b

Antenna Boost: Located in passenger-side overhead cabinet.

TV Antenna

The motorhome is equipped with a motorized, 12 Volt DC powered TV antenna. Operation of the antenna is conveniently controlled from a control panel located in the passenger side overhead compartment.

WARNING:

DO NOT raise the TV antenna near overhead electrical wires. Contact may cause serious injury or death. Do not move the motorhome when the TV antenna is up. There is an ANT UP warning light on the dash panel. When this light is lit lower the antenna before moving the motorhome.

To Raise the Antenna:

Visually check for clearance above the motorhome before raising the antenna. Press the **POWER** button to raise the antenna. Power is on when the indicator light is illuminated. One of the three middle lights on the control board will illuminate showing the current position of the antenna. Next press the **RAISE/STOW** button. The **MOTION** light will illuminate when the antenna is moving. The **MOTION** light turns off and the **RAISED** light illuminates when the antenna is fully extended.

NOTE:

Blinking lights indicate antenna is obstructed.

To Rotate the Antenna:

Press one of the **ROTATE** buttons to turn the antenna for improved reception. The **MOTION** light is illuminated when the antenna is moving. Hold **ROTATE** button to maintain antenna rotation. If **MOTION** light fails to illuminate while holding one of the **ROTATE** buttons the antenna has turned to its maximum clockwise counterclockwise position or is not extended to the up position.

To Lower the Antenna:

Press the **RAISE/STOW** button to lower the antenna into the stored position for travel. The **MOTION** light will illuminate. The antenna will automatically return to the down stowed position. At this time the **STOWED** light will illuminate. Push the **POWER** button to turn off the antenna and control board. Do not move the motorhome until the antenna is completely stowed and power is off. Make a visual inspection to confirm that antenna is stowed.

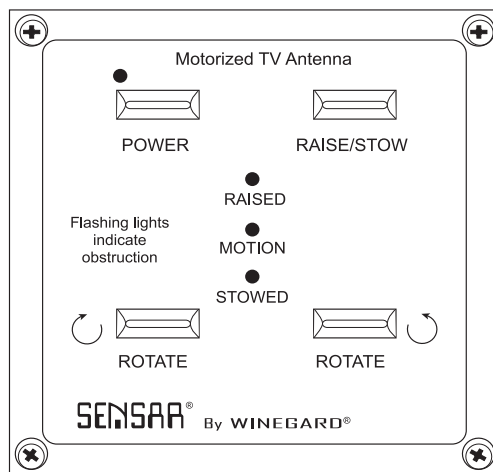

Located in front passenger overhead cabinet.

031268

CAUTION:

DO NOT move motorhome with antenna in the raised or partially raised position and risk damage by tree limbs or wires. Worm gear damage or breakage may result.

WARNING:

Before raising antenna, make an outside visual inspection for any obstructions or overhead electrical wires. Damage to the antenna, severe shock, personal injury or death can occur from inadequate clearance.

Television/Entertainment System - Front**To Operate Any Component:**

All the Entertainment Components require 120 Volt AC from shore power, the generator or the inverter to operate.

Ensure the battery cut-off switch is on and the house batteries are charged.

The ignition key must be in the **OFF** position.

NOTE:

Reading the individual components owner's manuals is strongly recommended. Many features and combinations for operating the entertainment system components are available.

To Watch TV from the Antenna or Shore Cable:

- ◆ Hook to shore power, start the generator or turn on inverter.
- ◆ Use the Battery Cut-Off switch to turn on interior house power.
- ◆ Turn on the TV. Press **Input** button until **TV** is displayed on input selection on upper right hand corner.
- ◆ Turn on roof antenna power. Extend antenna by pressing the **Raise/Stow** button.
- ◆ Select either Roof Antenna (**ON**) or Shore Cable (**OFF**) on the Antenna Boost Selector Switch.
- ◆ Select desired channel on TV.

To watch a DVD:

- ◆ Turn on the TV.
Select **Input 2**.
- ◆ Turn on DVD player.
- ◆ Insert DVD and push play if necessary.
- ◆ Adjust volume at DVD player.

To Watch Satellite:

- ◆ Turn on TV. Select **Input 4**.
- ◆ Turn on Satellite controller.
- ◆ Turn on Satellite receiver.
- ◆ Select channel using Satellite receiver.

NOTE:

Subscription to a Satellite provider is necessary to receive channels for viewing.

NOTE:

Inclement weather conditions may adversely affect the acquisition of a satellite signal. Degraded audio and video signals through the receiver will result.

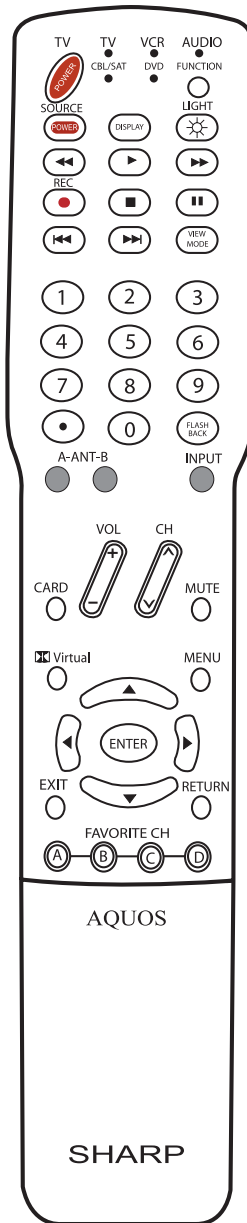

031161
LCD TV Remote

Television-Bedroom**To Watch TV from Antenna or Shore Cable:**

- ◆ Hook to shore power, turn on generator or turn on inverter.
- ◆ Use the Battery Cut-Off switch to turn on interior house power.
- ◆ Turn on TV.
- ◆ Turn on Roof Antenna power and raise antenna.
- ◆ Select either Roof Antenna (**ON**) or Shore Cable (**OFF**) on the Antenna Boost Selector Switch in front overhead.
- ◆ Press **TV/Video** button on TV until desired channel is displayed on upper right hand corner of TV.

To watch a DVD:

- ◆ Turn on TV. Select **Input 1**.
- ◆ Turn on DVD player. Insert DVD and push play if necessary.
- ◆ Adjust volume at TV.

To watch Satellite:

- ◆ Turn on TV. Select **Channel 3**.
- ◆ Turn on Satellite controller located in front curbside overhead.
- ◆ Turn on Satellite receiver.
- ◆ Select channel using Satellite receiver.

UNIVERSAL REMOTE

The universal remote is a custom programmed **INFRARED (IR)** remote control for all components of the entertainment system of the motorhome. There is extensive knowledge of component interaction and understanding of sequence control involved in the programming. The universal remote control eliminates the need for a number of other remotes.

NOTE:

Only qualified personnel using special equipment should program the Universal Remote.

NOTE:

Refer to OEM manual for detailed operating instructions.

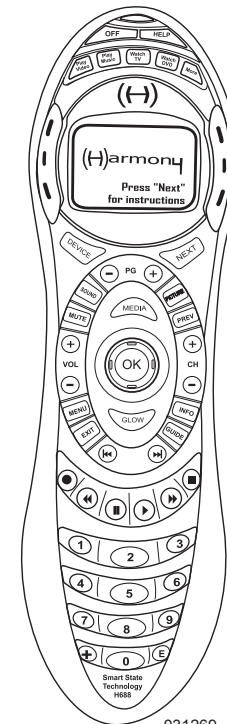

031269

SATELLITE Stationary System

The self-contained stationary, automatic satellite TV system automatically acquires and tracks DirecTV®, DISH Network™ and Bell ExpressVu satellite signals throughout the continental United States when the motorhome is in a stationary position.

NOTE:

The satellite is a self-acquiring satellite TV antenna for use when the motorhome is stationary. The system is not designed to track the TV satellite when the motorhome is in motion.

NOTE:

For specific satellite coverage areas and providers see the OEM manual.

The **Internal Receiver Descrambler (IRD)** receives satellite signals from the antenna for decoding, processing, and channel selection, and then sends those signals to the TV for viewing. The IRD also provides the interface for the user to activate authorization for reception.

INFORMATION:

Refer to the IRD User's Manual for complete operating instructions.

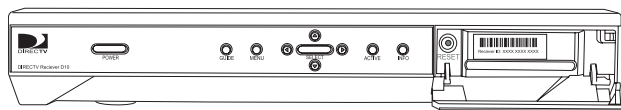

Satellite Receiver

031196b

The satellite system requires a clear view of the southern sky to receive signal. Ideal antenna site has an unobstructed view of 15° to 75° in the Southern horizon.

If the satellite antenna receives intermittent signals or cannot locate the satellite, check around outside of motorhome for blockage such as trees, building, etc. The satellite antenna must be located in the selected satellite's coverage area in order to receive a signal.

NOTE:

The satellite receiver must be turned on for the system to function.

NOTE:

As part of the startup process, the System will default to channel 200, a program directory. This is the system's means of verifying that it has identified and is tracking the correct satellite. Once channel 200 appears, wait at least another 30 seconds before changing the channel to ensure that the system has completed the startup routine.

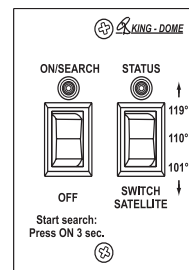

031199

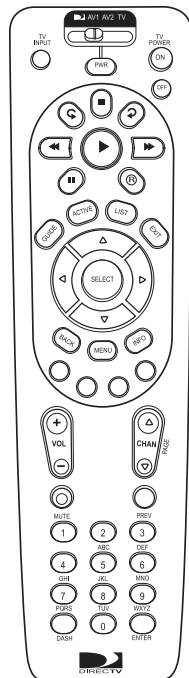

Remote 031197

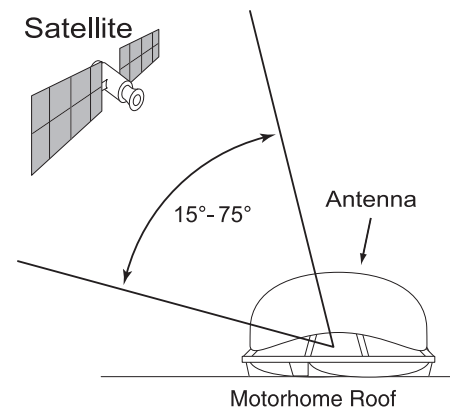

031027b

For Dish 500 subscribers:

After being locked onto a satellite Dish 500 subscribers can switch back and forth between the 110 and 119 satellites.

To switch satellites:

Press and hold the 3 position switch for 1 second. Up will switch to 119 while down will switch to 110.

System Start-up:

- ◆ Upon power-up, the system performs a set of start-up routines.
- ◆ Antenna then searches for a TV satellite.
- ◆ After locating a satellite, the IRD data connection determines whether the satellite signal can be decoded. If so, the antenna locks onto and tracks the satellite.

NOTE:

Once the startup procedure is complete and the antenna is locked onto the correct satellite, the power switch may be turned off to avoid unnecessary discharge of house battery power. Because the antenna LNB receives its power from the IRD, the antenna will continue to receive the satellite TV signals and relay them to the IRD.

NOTE:

If the antenna is unable to locate the desired satellite, refer to the OEM Manual for possible causes and corrective actions.

“Instant On” Operation:

As part of operation, the satellite routinely saves its position to memory. When turned on, the system looks at the last saved position and if the motorhome has not changed location, the antenna will immediately acquire the signal.

If the motorhome moves after the system is turned off, the antenna will quickly carry out normal initialization routine to re-acquire the satellite. To turn the system off, press the **Power** button.

NOTE:

It is highly recommended that the system be turned OFF prior to moving the motorhome. The system will not track a satellite while the motorhome is in motion.

The system requires the following preventive maintenance for optimum performance.

Monthly:

- ◆ Wash the exterior of the radome and base plate assembly with fresh water; a mild detergent may be added to remove grime. **DO NOT** spray the radome directly with high-pressure water.
- ◆ **DO NOT** apply abrasive cleaners or volatile solvents, such as acetone, to the ABS dome.

Annually:

- ◆ Have the satellite system inspected by a professional RV technician or satellite installer.
- ◆ Apply full strength liquid dish detergent to the dome surface and allow it to dry. This treatment provides a film on the dome surface that will allow moisture to bead up and roll off.

NOTE:

If a need arises to paint the radome, **ONLY** use non-metallic automotive paint to avoid degrading the RF signal strength and the reception quality.

INFORMATION:

For information on warranty, repair, and liability policies, refer to the complete warranty statement provided with the OEM Manual.

NOTE:

For optimum signal strength, keep the dome clean from dirt, bugs and other debris. Periodic washing of the dome with mild soap and water is recommended. If the motorhome is to be stored for long periods of time it is recommended that the system be put through a search procedure on a quarterly basis to keep all moving parts in good working order.

In-Motion System (Optional)

In-Motion Satellite System:

The In-motion system will automatically track the satellite during travel. If the motorhome is parked the control panel can be turned off to conserve battery power after the system has obtained the signal. To turn the control panel off simultaneously press the **Enter** and – buttons.

To Use the In-Motion System:

- ◆ Press the **On** button on the satellite control panel. The dish will automatically acquire the signal from the satellite.
- ◆ Ensure the access card is inserted and press the **Power** button on the satellite receiver. The green LED on the receiver will illuminate.

NOTE:

Inclement weather conditions may adversely affect the satellite signal acquisition. Degraded audio and video signals through the receiver will result.

NOTE:

A HD (high definition) ready receiver is optional with the In-Motion Satellite System (N/A for bedroom). Channel availability will vary with satellite system and providers. Consult the OEM manual for providers, coverage areas and channel availability.

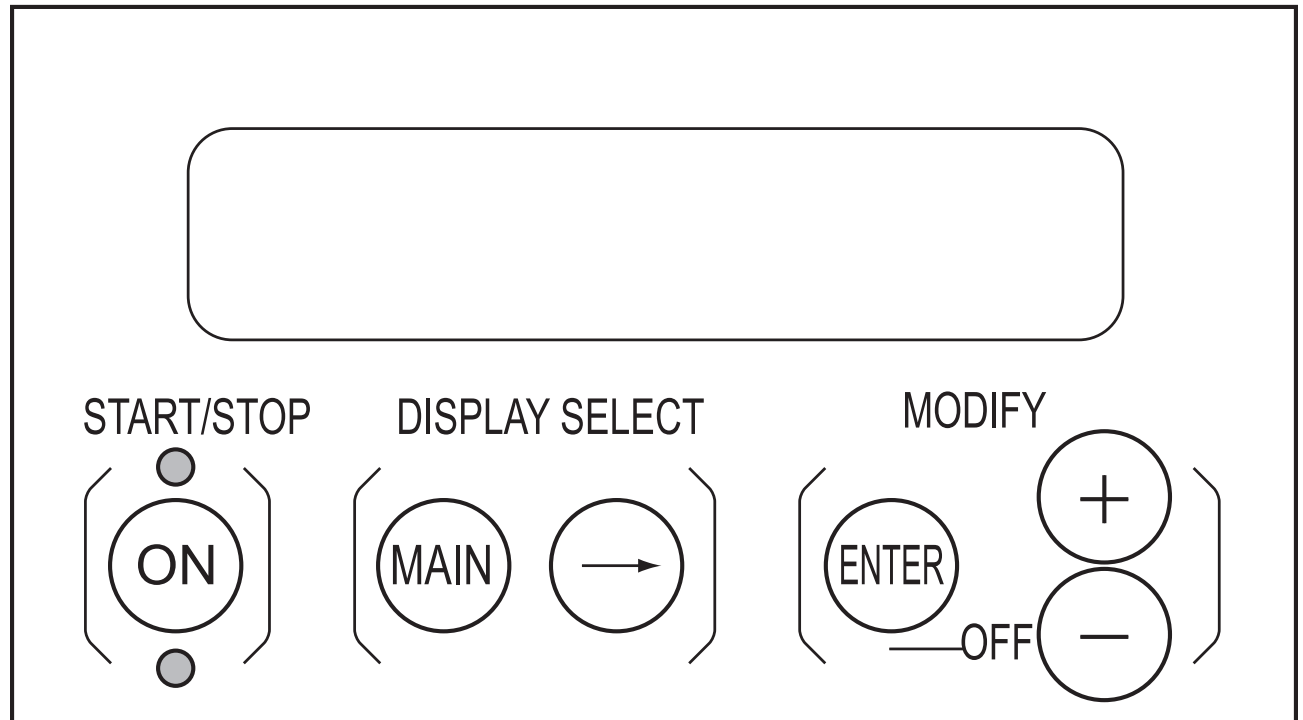

Control Panel

031033b

THE EXECUTIVE 07

WATER SYSTEMS — SECTION 6

WATER SYSTEMS - INTRODUCTION	150	WASTE WATER SYSTEMS	158
WATER TANKS	150	Proper Waste Disposal	158
Measurements & Calibration	150	What Not to Put in Waste Holding Tanks	158
WATER- POTABLE	151	What to Put in Holding Tanks	159
Hose Reel	151	Waste Pump	159
City Hook-Up	151	TOILET	160
Fresh Tank Fill	151	Cleaning & Maintenance	161
Gravity Fill	152	Drain Traps & Auto Vents	161
PLUMBING MANIFOLD	152	Cold Weather Conditions	161
WATER PUMP	152	Cold Weather Storage	161
Water Pump Troubleshooting	153	WINTERIZATION	162
PRESSURE ACCUMULATOR TANK	153	Using Air Pressure	162
WATER FILTERS	154	Using Nontoxic Antifreeze	162
Galley Water Filter & Sanitizer (OPT)	154	De-Winterization	163
Maintenance	155	SERVICE CENTER	164
WATER SYSTEMS	156	WATER BAY	165
Troubleshooting	156	WATER SYSTEM DIAGRAM	166
Disinfecting Fresh Water	156		
FAUCETS	157		

WATER SYSTEMS - INTRODUCTION

This section contains information about the operation and care of various water system equipment found in the motorhome. Optional water equipment will also be discussed, so not all information may be applicable to each motorhome. More detailed information with **CAUTION** or **WARNING** instructions for various equipment, other than what is found in this section, can be found in the OEM manuals in the owner information box.

It is hard to imagine how much water is used by the average person. Newcomers to a self-contained motorhome soon discover water does not last long unless consumption is drastically reduced. For example, less water can be used for showering if the shower is turned off while soaping down, then turned back on to rinse. This way a good shower uses a couple gallons of water or less. There is plenty of water to meet personal needs once habits are adjusted.

Fresh Water System:

The fresh water system consists of a fresh water tank, water pump, gravity fill connection, water filter(s) and a water hose for potable water use only. Proper care of the hose is necessary. After each use, drain the water hose. Roll the hose up onto the hose reel. Attach the plug to keep out insects and debris.

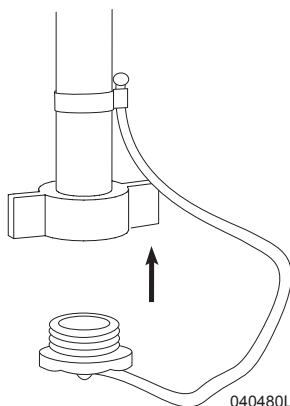

Domestic Hot Water:

The Aqua-Hot system produces and maintains a supply of hot water.

Waste Water System:

The waste water system consists of a waste holding tank (grey water), sewage holding tank (black water), flush system, toilet and drains.

WARNING:

Water is electrically conductive. DO NOT use any electrically powered item or electrical outlet that may be exposed to a water source. Such use can result in a serious shock, causing injury or death.

WATER TANKS Measurements & Calibration

The Aladdin™ system monitors holding tank capacity. There are two ways in which the Aladdin™ system can monitor the tank status.

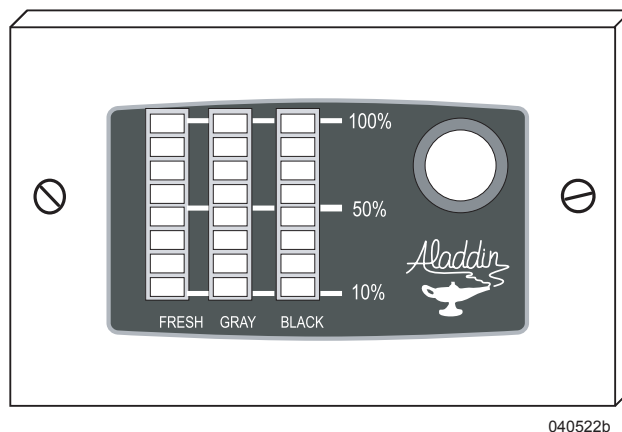

At the service center:

Located in the water service center is a monitor panel that will indicate at a glance the tank status of the Fresh, Grey and Black tanks. Readings are displayed in 10% increments. Press the **green** button to turn on the Aladdin™ system. The status bars illuminate when the system is operating.

NOTE:

The monitor panel will shut down automatically in 20 minutes.

Inside the motorhome:

Access the **Main Menu**, and move the joystick until the cursor is next to **Coach Tank/Misc Status**. Move the joystick right to display tank status.

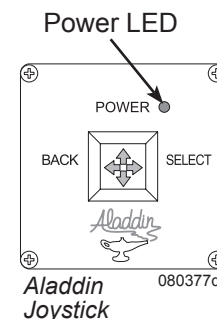

MAIN MENU

- ENGINE/TRANS STATUS
- COACH ELECTRICAL STATUS
- > COACH TANK/MISC STATUS
- TRIP METER SELECTION
- TIME/ALARM FUNCTIONS
- SELECT VIDEO SOURCE
- SYSTEM OPTIONS
- POWER DOWN ALADDIN

The Coach Tank/Misc Status Screen

Displays:

- ◆ Fresh, grey and black tank percentage full and corresponding gallons.
- ◆ LP-Gas tank level.
- ◆ Basement and outside temperatures.
- ◆ Compass heading.

COACH TANK/MISC STATUS		
	PCT	GAL
FRESH TANK	XXXX	XXXXXX
GRAY TANK	XXXX	XXXXXX
BLACK TANK	XXXX	XXXXXX
LP TANK	XXXX	XXXXXX
BASEMENT TEMP	XXXX	F
OUTSIDE TEMP	XXXX	F
COMP HEADING	XX	XXX

**WATER- POTABLE
Hose Reel**

The convenience of the water hose reel eliminates storage of the potable water hose in a bay. The water reel is located in the roadside service center, equipped with a 12 Volt DC motor to retract the hose after use.

CAUTION:

Some outside water sources develop high water pressure, particularly in mountainous regions. High water pressure is anything over 55 psi (pounds per square inch). Excess water pressure may cause leaks in water lines. Excess pressure on a hot day can cause the water hose to swell and burst. An additional pressure regulator can be connected to the city water faucet to regulate pressure to the potable water hose.

City Hook-Up

- ◆ Remove hose plug and install a water pressure regulator to the water hose.
- ◆ Pull hose from reel and connect the water hose to a City Water hook-up.
- ◆ Turn the City Water/Tank Fill valve to the City Water position (full clockwise).
- ◆ Turn on the water supply.
- ◆ The water pump can be off or on. It will not affect the water pump to leave it on.



Fresh Tank Fill

- ◆ Remove hose plug and install a water pressure regulator to the water hose.
- ◆ Pull hose from reel and connect the water hose to a City Water hook-up.
- ◆ Turn the City Water/Tank Fill valve to the Tank Fill position (full counterclockwise).
- ◆ Turn on the water supply.
- ◆ The water pump should be off.
- ◆ The water tank is full when water comes out of the tank overflow pipe located on the curbside of the motorhome. Shut the water supply off as soon as possible.

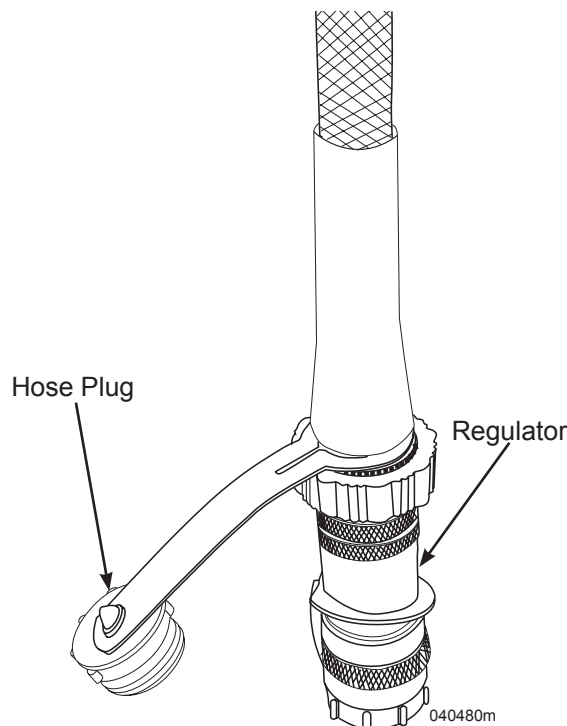

Water Pressure Regulator attached to Hose Reel.

NOTE:

When filling the fresh water tank, do not leave the hose unattended. Turn water off immediately when water appears from the overflow discharge on the curbside, ahead of the drive axle.

To Retract the Hose Reel:

- ◆ Disconnect the water hose from the faucet. Do not leave water regulator attached to faucet.
- ◆ Press the retract switch and guide the hose onto the reel.
- ◆ Install plug in hose when not in use.

Maintenance:

When using the hose, look for kinks. Periodically extend the hose completely. Straighten the hose on the ground. It is important that the water hose remains clean.

Gravity Fill

The gravity fill inlet allows fluids to be added directly into the fresh water tank. When dry camping, water can be poured directly from a container into the fresh water tank. The gravity fill inlet can also be used to add disinfectant solution to the fresh water tank. Use only potable water sources, solutions and delivery systems when using the gravity fill inlet.

Gravity Fill Opening

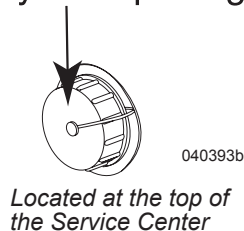

Located at the top of the Service Center

Filling the Tank:

1. Unscrew fill cap taking care to keep cap and inlet clean.
2. Insert potable water hose into inlet.
3. Fill tank until water overflows from inlet.

NOTE:

DO NOT leave the gravity fill inlet unattended when in use.

PLUMBING MANIFOLD

The plumbing manifold is located behind a latching door in the plumbing service center. The manifold separates the main hot and cold lines. The main hot and cold inputs are divided into the individual branch lines.

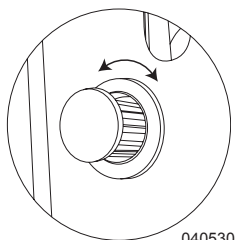

To Open Manifold Door: Press knob to expose. Turn clockwise or counterclockwise.

Water flows unrestricted with no hidden fittings located behind walls.

Each faucet or appliance water line may be turned off. Hot water valves are located on the left; cold water valves on the right. Use the provided key to turn on or off a water line. When the key is horizontal, the water line is open. Turning the key to the vertical position shuts that water line off. Each water line is labeled for easy reference. Snap the key into the key storage after use.

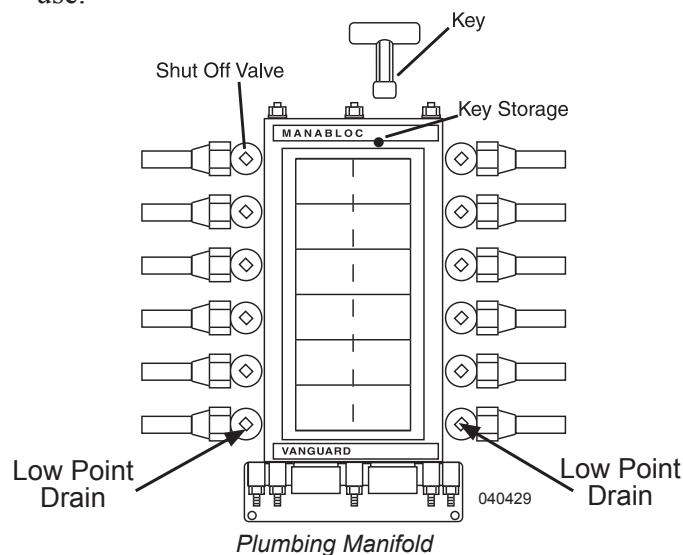

WATER PUMP

The water pump pressurizes the fresh water system when not connected to city water. The water pump is self-priming, operating on demand as water is used. The water pump is located behind the service center. The pump may be accessed from the storage bay next to the service center.

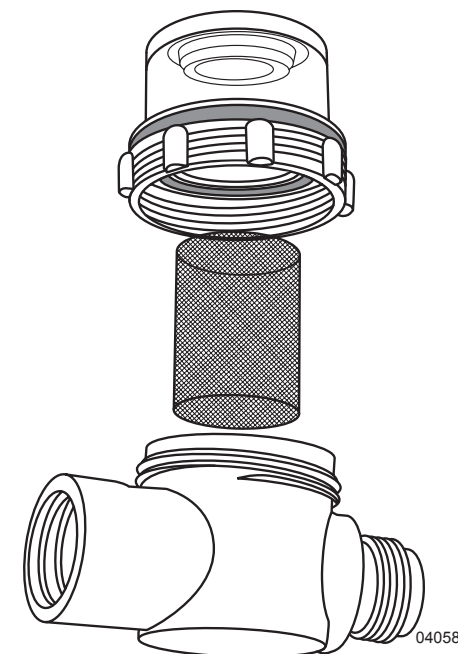

Water pump inlet screen: Located behind plumbing manifold door. Clean every two months.

WARNING:

Before leaving the motorhome for extended periods of time (i.e. overnight or longer) be sure that the city water supply and water pump have been turned off. Damage from neglect will be the responsibility of the owner, not the manufacturer.

The water pump can be operated from these following locations:

- ◆ Bathroom/Vanity
- ◆ Galley
- ◆ Service Center

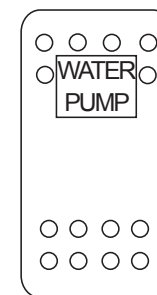

080335c
Service Center
Water Pump
Switch

To turn the water pump ON or OFF:

- ◆ Momentarily press the water pump switch. The indicator lamp on the interior switch, or the LED on the service center switch, will illuminate when the water pump is turned on.

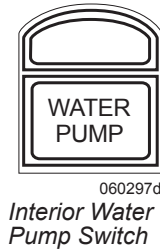
**CAUTION:**

DO NOT continue water pump operation if the fresh water holding tank is empty. Damage to the water pump or electrical supply system may result.

To operate the water pump after unhooking from a city water supply or after storage:

- ◆ Close all drain valves and low point drains.
- ◆ Fill the fresh water tank.
- ◆ Open the hot and cold water valves of each faucet.
- ◆ Turn the water pump **ON**. Wait for the water lines and the hot water tank to fill.
- ◆ Close each faucet when it delivers a steady stream of water (cold water faucets first).

Water Pump Troubleshooting

Vibration induced by road conditions can cause the plumbing or pump hardware to loosen. Check the water pump system for components that are loose. Many symptoms can be resolved by tightening the hardware. Check the following items:

Water pump will not start or blows the fuse:

- ◆ Check the electrical connections, fuse or breaker, main switch and ground connection.
- ◆ Is voltage present at the pressure switch on the pump? If voltage is present, the pressure switch may be faulty. As a test, temporarily bypass the pressure switch.
- ◆ Check the charging system for correct voltage and good ground.
- ◆ Check for an open or grounded circuit or motor.
- ◆ Check for a seized or locked diaphragm assembly (water frozen).

Water pump will not prime or sputters (No discharge/motor runs):

- ◆ Is the pump inlet strainer clogged with debris?
- ◆ Is there water in the tank or has air collected in the water heater?
- ◆ Is the inlet tubing and plumbing sucking in air at plumbing connections (vacuum leak)?
- ◆ Check for proper voltage with the pump operating.
- ◆ Check the pump housing for cracks or loose drive assembly screws.

Water pump will not shut-off or continues to run when the faucet is closed:

- ◆ Check to see if the fresh water/tank fill valve is completely closed.
- ◆ Check the output (pressure) side plumbing for leaks and inspect for a leaky toilet or valves.
- ◆ Look for a loose drive assembly or pump head screws.

Water pump is noisy or rough in operation:

- ◆ Check for plumbing that may have vibrated loose.
- ◆ Does the mounting surface multiply noise (flexible)?
- ◆ Check for mounting feet that are loose or compressed too tight.
- ◆ Look for loose pump head to motor screws.

Water pump is rapid cycling:

- ◆ Look for restrictive water flow in the faucets or shower heads.

PRESSURE ACCUMULATOR TANK

The pressure accumulator tank mounts in the water bay near the water pump. The pre-charge pressure in the accumulator tank should be checked monthly. The tank can be accessed behind a sliding panel in the compartment next to the water service bay.

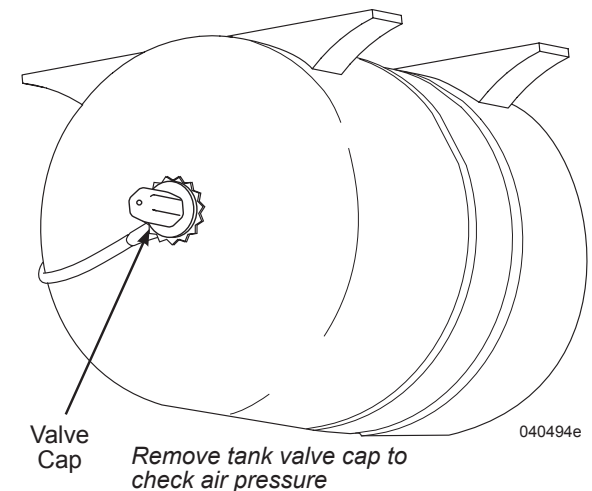

Accumulator Features:

1. Smooth flow from the faucets.
2. Reduced water pump cycling.
3. A pre-charged air cushion.
4. Elimination of pulsation and water hammer.
5. Sustained water pressure at faucets before pump cycles on.

The accumulator tank includes a valve designed to pre-charge the tank with air pressure. Pre-charge pressure must not exceed water pump cut-in pressure, the pressure at which the pump restarts. The water pump has a cut-in pressure of 40 psi. Pre-charge pressure of the accumulator tank is 18 to 22 psi. To check air pressure in the accumulator tank, the water pump and city water will need to be off. Open a faucet to relieve the water pressure. Check the accumulator tank pressure monthly using a tire air pressure gauge (one that reads low air pressure). Use a hand-operated pump to add air pressure to the accumulator tank only when needed. The amount of airflow and high-pressure from a compressed air system can quickly overcharge the tank, causing the internal bladder or tank to rupture.

WATER FILTERS

The two-stage filtration system uses the following filters:

- ◆ **First Stage - Five Micron Sediment Filter:** For reduction of suspended solids, dirt and rust. Life expectancy varies with incoming water condition. Recommended change interval depending on usage and incoming water quality.

- ◆ **Second Stage - Five Micron Carbon Block Filter:** Improve water quality by reducing objectionable organic chemicals, chlorine, tastes and odors. Recommended change interval depending on usage and incoming water quality.

- ◆ Prior to disinfecting the water system with a chlorine bleach solution, remove the filter elements and reassemble the filter bowls without the elements. Use the following procedure to remove or change the filter elements.

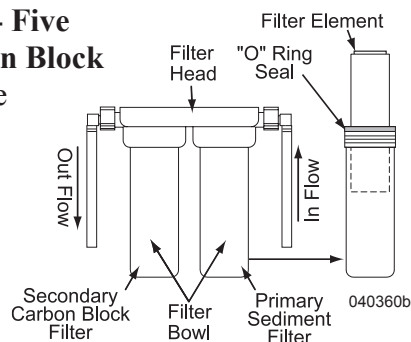
**Removing the Filter:**

- ◆ Turn **OFF** the water supply and the water pump.
- ◆ Open the hot and cold faucets at the service center shower to bleed off pressure.
- ◆ Unscrew the filter bowl from the filter head using the water filter removal wrench.
- ◆ Remove the old element and empty any remaining water in the bowl.

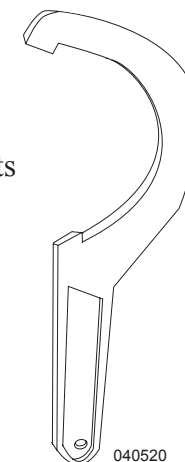

Water Filter Removal Wrench

Installation:

- ◆ Place the elements in the bowls, observing primary and secondary filter locations.
- ◆ Screw the bowls onto the filter heads and tighten by hand.
- ◆ Turn **ON** the water pump or city water.
- ◆ Close the outside shower faucet after all the air is purged from the filter assembly.
- ◆ Check for leaks.

Galley Water Filter & Sanitizer (Optional)

The water filters connect to the galley cold water supply. The dispenser is mounted to the galley top. The unit is located in the roadside compartment mounted below the motorhome's water filters.

The system provides two levels and types of filtration, and then injects ozone gas as the final stage disinfectant. The 1st stage filter is a particulate filter to remove dirt, rust and other contaminants from the water. The 2nd stage filter is a carbon block filter to remove chlorine, organics and other impurities. The ozone injection, between .2 and .25 parts per million at one gallon per minute, destroys micro-organisms and adds a high level of oxygen to the water. Any ozone taste will disappear within a few minutes.

The water can also be used for increasing food freshness and extending food shelf life, as well as sanitizing countertop surfaces and dishes.

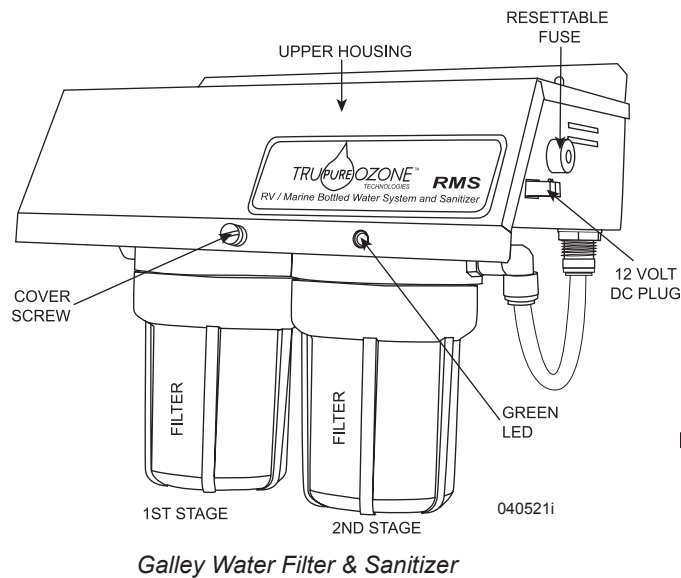

Galley Water Filter & Sanitizer

CAUTION:

If a leak should occur, immediately close the supply valve (labeled galley) at the plumbing manifold. Contact a dealer for service.

Inside the upper housing are the following:

- A. Electronic Module
- B. Transformer
- C. Electrode Heat Sink
- D. Ozone Electrode Assembly
- E. Ozone Gas Transfer Line
- F. Anti-backflow Electronic Solenoid Valve
- G. Ozone Atomizing Injector
- H. Cleanable Glass Borosilicate Dielectric

CAUTION:

Turn off galley water supply at the plumbing manifold and unplug power from right side of unit before removing cover, changing filters, servicing or maintaining.

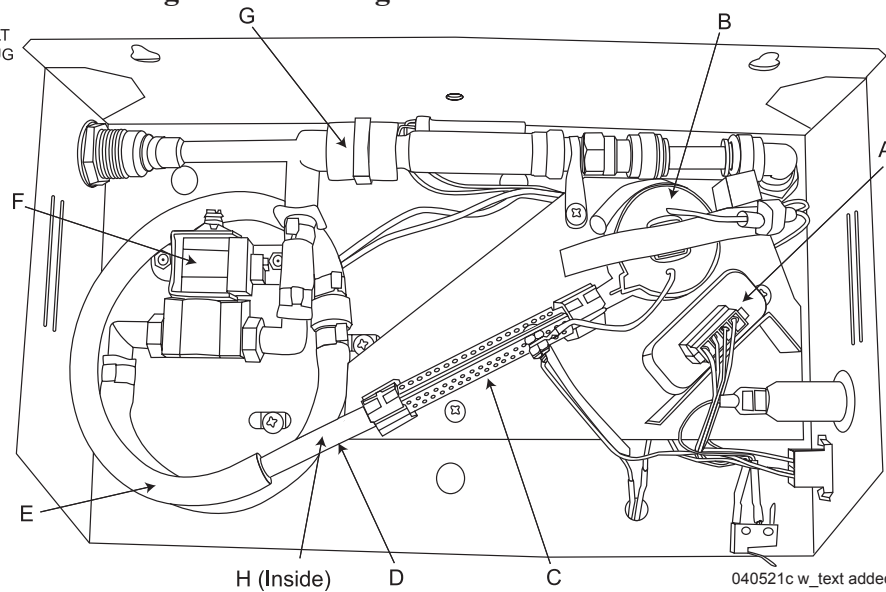

Maintenance

Clean the borosilicate dielectric every 30-60 days. Change the 1st and 2nd stage filters every 3 to 6 months.

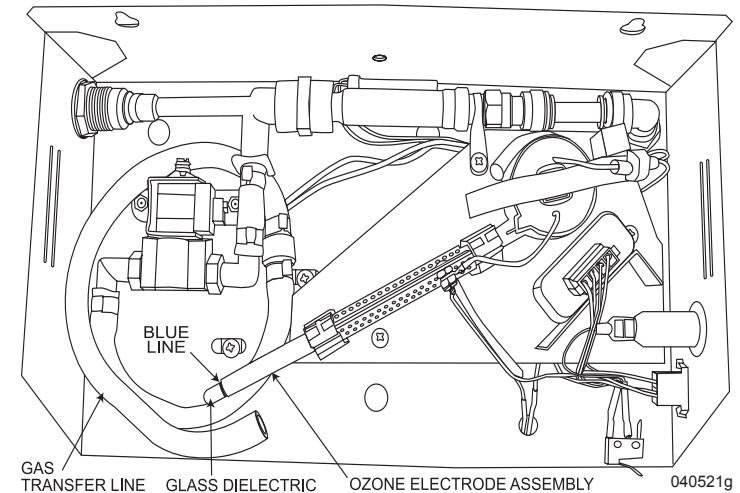

To Clean the Borosilicate Dielectric:

1. Remove cover to expose ozone generator.
2. Gently remove the end of the ozone gas transfer line from the left end of the ozone electrode assembly.
3. Grasp the rounded end of the glass dielectric and pull straight out until it is completely free from the stainless steel Ozone Electrode Assembly.

- Moisten a soft cloth or thick paper towel with soapy water and carefully wipe clean any buildup of the dielectric glass. Dry the glass completely. If the stain on the glass is difficult to remove, apply a small amount of baking soda to the cloth and clean outside of tube.

CAUTION:

DO NOT submerge or allow water to enter into the dielectric. If this happens, place the dielectric on a paper towel in a microwave for one minute or until no moisture is present. Wait for dielectric to cool before handling.

- Wait for the glass dielectric to completely dry. Gently insert the dielectric back into the stainless steel Ozone Electrode Assembly. Carefully slide the glass dielectric over the stainless steel rod that is inside the outer shell until it seats at the base.
- Replace the black ozone transfer tubing over the end of the ozone electrode assembly.
- Replace the outer unit cover and restore power.

WARNING:

Ensure glass dielectric tube is pushed all the way up to the blue line before start-up.

To Change the 1st and 2nd Stage Filters:

- Use latex gloves to avoid cross-contamination between old and new cartridges or exposing yourself to contaminants that have been filtered from the water.

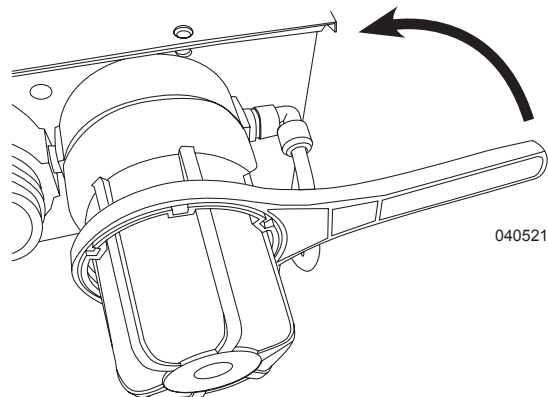

Use wrench to loosen stage filter only.

- Turn off the water supply by using the galley valve on the Plumbing Manifold.
- Relieve pressure by opening unit faucet at sink.
- Place a shallow container under the filter sump to catch any remaining water. Grasp the left 1st stage (XP) filter sump bottom and unscrew using the filter wrench.
- Remove the old cartridge and dispose.
- Repeat steps 4 and 5 for 2nd stage (XC) filter.
- Wash both filter sumps with warm soapy water and rinse.
- Place new cartridges labeled #1 and #2 in the sump bottoms and re-install matching filter numbers to unit. Hand tighten only. Do not use a wrench.
- Open cold water supply valve and turn on Tru-Pure Faucet until all air is purged from filter housings and water.
- Check for leaks.

CAUTION:

DO NOT allow system to be exposed to temperatures below 32° F or over 120° F or exceed operating pressure of 80 psi.

Testing the Unit:

- Turn on the cold water supply to the unit and open the water dispenser to purge air from the system.
- Confirm that the green light illuminates after a few seconds.
- If the green LED on unit does not illuminate, confirm that power is ON. If the power indicator still does not light and power is on, check the resettable fuse on the side of the unit.

WATER SYSTEMS***Troubleshooting***

If the water pump cycles after closing the faucets, drain valves and inlet valves, a leak may be present. At this time check for leaks around fittings, valves, filters, and connections of the hot and cold water system. If problems continue take the motorhome to an authorized dealer for repairs.

Disinfecting Fresh Water

Disinfecting the water system with household bleach (superchlorination) protects against bacteriological or viral contamination from common water sources.

Disinfect the fresh water system:

- ◆ If the motorhome is new.
- ◆ If the motorhome has been in storage.
- ◆ Every three months during use.

To Disinfect the Water System:

1. Remove water filter elements and re-install the filter housings.
2. Drain the fresh water tank. Close drain when done.
3. Prepare a disinfecting solution using one of the following methods:
 - ◆ Combine one gallon of water and ¼ cup of household bleach. Use 1 gallon of this solution for every 15 gallons of tank capacity.
 - ◆ Multiply tank capacity (in gallons) by 0.13. The result is the amount (in ounces) of household bleach to pour into fresh water tank. These methods will yield a 50 PPM (parts per million) disinfecting solution in the water system that will act as a quick-kill dosage for harmful bacteria, viruses and slime-forming organisms. Concentrations higher than 50 PPM may damage the water lines and/or tanks.
4. Pour the solution into the gravity fill opening.
5. Top off tank with fresh water.
6. Turn **ON** the water pump in the motorhome.
7. Open each faucet and run water until you smell a distinct bleach odor.
8. Turn **OFF** all faucets and allow the system to stand for four hours.
9. Drain the fresh water tank of the mixed solution.

10. Fill the water tank with fresh water. Thoroughly flush hot and cold lines with fresh water. Repeat this process until the chlorine bleach smell is no longer detected in the water.
11. Install new water filters.

TIP:

Use the same hose labeled for potable water to introduce the chlorine solution into the system. This will disinfect the potable water hose at the same time. Several flushes will be required to remove chlorine residue from the potable hose.

INFORMATION:

Household bleach is 5.25% Sodium Hypochlorite. Higher concentration will increase PPM ratio.

Aqua-Hot:

The Aqua-Hot copper tubing is rated for use with fresh water and winterizing solutions only. Periodic flushing with other common household chemicals, including bleach, will have little or no effect on the product if properly rinsed with fresh water. Failure of copper tubing, especially soft or flexible copper, can result when materials other than water or winterizing solutions are allowed to reside inside the piping for extended periods of non-use. The most common cause for failure is due to an extended exposure to chlorine, solutions containing chlorine (i.e. bleach) or hydrochloric acid.

CAUTION:

DO NOT use vinegar to disinfect the water system. Vinegar will deteriorate the copper tubing inside the Aqua-Hot Domestic Water Loop. Thoroughly rinse chlorine bleach or other concentrated chlorine bearing chemicals as they can also cause failure to the Aqua-Hot Domestic Water Loop (copper tubing).

FAUCETS

Several different faucets are used in the galley and bath areas. Some faucets dispense both hot and cold water, some dispense only hot and others dispense filtered cold water.

The smaller faucet is the Insta-Hot (optional) which provides only hot water.

The galley faucet head has a flexible hose which allows removal from the base. O-rings seal the faucet head to the base to prevent water from dripping into the cabinet. A slide bar on the faucet head selects either stream or spray.

A liquid soap dispenser is also provided in the galley for hand washing.

Galley Faucet Screen:

Fresh water sources will vary by location. Build up of lime deposits, or debris on the faucet screen, will restrict or plug the flow of water coming from the faucets. Should the flow of water reduce, the filter screen in the faucet head may be clogged. All faucet screens should be checked and cleaned every two weeks of use.

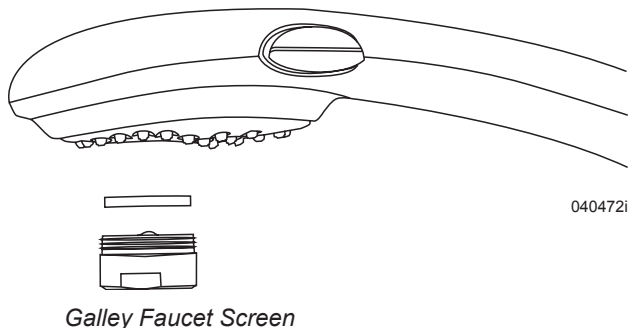

- ◆ The galley faucet has a screen in the handle. Remove the faucet head from the base to unscrew the hose from the faucet head to clean the screen.

Liquid Soap Dispenser:

The liquid soap/lotion dispenser can be used with any type of liquid soap or lotion. The liner of the bottle will not corrode or discolor the contents of the dispenser. To clean, use a soft cloth and blot dry. Harsh abrasive cleansers or polishes can damage the finish on the dispenser.

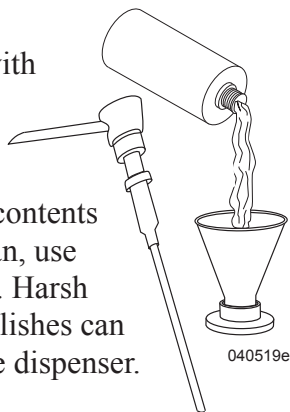

- ◆ Lift the dispenser pump out of the bottle.
- ◆ Use a funnel to fill the bottle with liquid soap or lotion.

Lavatory Faucet Screens:

- ◆ Lavatory faucet screens are normally located on the outlet side of the faucet and held in place with a threaded collar. Remove screen from faucet.
- ◆ Clean screen using a small soft brush, if necessary, and a de-liming solution.
- ◆ Install screen and check water flow.

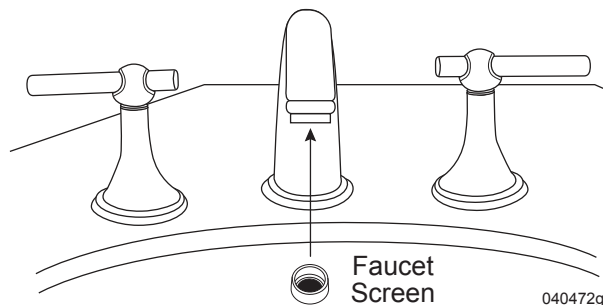

WASTE WATER SYSTEMS

Proper Waste Disposal

Dumping raw sewage from toilet holding tanks, except at authorized dumping stations, is universally prohibited. Most National, State and private parks have either a central dump facility or campsite hook-up for sewage. Many modern rest areas along the interstate now have dump stations available. Woodall's Campground Directory, Trailer Life's RV Campgrounds and Services Directory, Rand McNally's Campground and Trailer Park Guide, Good Sam Park Director (Good Sam Club) and other similar publications list dumping stations. Some major oil companies offer dump facilities at selected stations also.

What Not to Put in Waste Holding Tanks

- ◆ **DO NOT** use strong or full strength detergents to deodorize and disinfect. Use odor control chemicals made especially for holding tanks.
- ◆ Automotive antifreeze, ammonia, alcohol or acetone in holding tanks will dissolve plastic.
- ◆ **DO NOT** dispose of table scraps into the tanks. They can clog pipes or damage the valve seals.
- ◆ Facial tissue is thicker, softer and stronger than a rapidly dissolving tissue. White toilet paper dissolves faster than colored. To test tissue dissolving ability, immerse one tissue square into a jar of water. Shake the jar five times to determine how the tissue disintegrates. **DO NOT** use any type of tissue that remains in one piece. Paper designed specifically for holding tanks is available at most RV supply stores.

NOTE:

Never dispose of sanitary supplies or other non-dissolving items into the system. Facial tissue, wet strength tissue, paper towels or an excessive amount of toilet tissue can create clogging in the holding tank system.

CAUTION:

DO NOT use any products that contain petroleum distillate or ammonia in place of RV odor controlling chemicals. Petroleum distillate or ammonia will damage the ABS plastic holding tanks and seals.

What to Put in Holding Tanks

Grey Water Tank:

The grey water waste tank stores the sink, shower and clothes (optional) washer drain water. A reduced mixture of chemicals may help to control odor in the grey tank.

Ensure that there is enough liquid in the holding tanks prior to dumping the waste holding tanks to provide a smooth flow through the valve, drain pipe and drain hose. Empty the waste holding tanks weekly to prevent stagnation and overflowing.

Black Water Tank:

Before initially operating the toilet, treat the sewage holding tank with a pre-charge of water and an odor-control chemical (available at most RV supply stores). First, add approximately three gallons of water to the holding tank. Next, mix the chemicals, in accordance with the manufacturer instructions, with approximately one gallon of water. Pour mixture through toilet to the holding tank. Be careful not to spill the chemical on hands, clothing, toilet bowl or carpet. Hot weather conditions may require adjusting the amount of chemical used to control odor. Repeat the chemical pre-charge to the holding tank each time the tank is cycled.

WARNING:

Most chemical mixtures for holding tank odor control are poisonous. Follow the product manufacturer's directions and warnings when using holding tank additive. DO NOT use any products that contain petroleum distillate or ammonia in place of RV odor controlling chemical. Petroleum distillate or ammonia will damage the ABS plastic holding tanks and seals.

Waste Pump

The waste pump is a self-priming impeller pump designed to minimize clogging when draining the tanks. The system comes with a 1 1/2" outlet hose with sewer pipe adapter and a 13 gallon per minute macerator pump.

To Empty the Black Tank:

- ◆ Secure the 3" flexible hose from the macerator pump to the termination point on the dump connection.
- ◆ Remove drip cap at 1 1/2" hose end.
- ◆ Insert hose end into sewer connection.
- ◆ The waste pump is also equipped with a threaded adapter that will allow the hose end connection to be adapted from 3" to 3 1/2" and 4" threaded sewer connections. Thread the red adapter into the sewer connection, and press the threaded end of the sewer hose into the adapter. Ensure the hose end is installed correctly prior to operation.
- ◆ Open the solid waste drain valve at the plumbing service center by pulling outward. Turn on the pump using the SANICON switch at the service center panel.

- ◆ When the black tank is empty, turn off the pump and leave the black tank valve open.

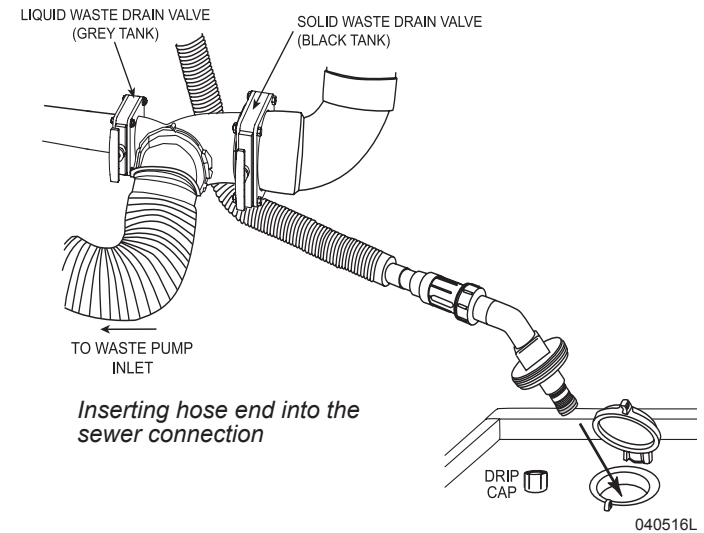

To Rinse the Black Tank:

- ◆ With the black tank valve left in the open position open the grey tank valve. This will allow half of the grey tank liquid to flow into the black tank. Gravity will equalize the volume in the tanks in a few moments.
- ◆ Close the grey valve and turn the pump back on to rinse the black tank. This process may be repeated to rinse the tank again.

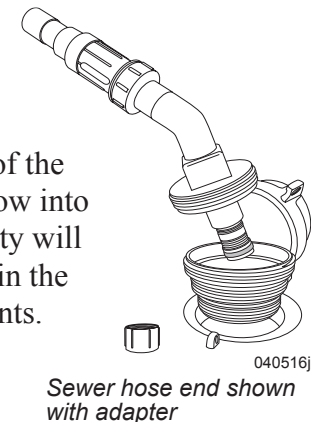

To Empty the Grey Tank:

- ◆ With sewer attachment installed open the grey tank valve and turn on the pump.

Grey Water Bypass:

The grey water bypass system allows continuous grey water flow. The liquid (grey) waste uses gravity to drain from the tank and bypasses the pump by going through the bypass hose into the sewage service. The bypass hose is the small hose connected at the termination point of the dump valves and “T-s” into the small flexible hose on the outlet side of the Macerator pump.

Troubleshooting:

- ◆ For the macerator pump to run the chassis battery disconnect switch in the battery compartment needs to be on.
- ◆ 12 Volt DC power for the macerator pump comes from the chassis batteries and is protected with a 20 Amp fuse located on the rear run box.

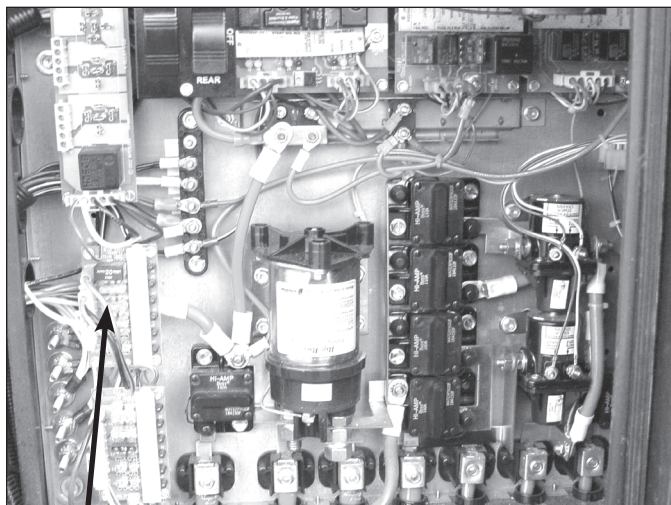

R4 Circuit Board

Rear Run Box: Located in the engine compartment.

TOILET

The toilet uses water from either the fresh water tank or a city water supply. The water pump must be turned **ON** or connect the motorhome to city water. The toilet uses 12 Volt DC to flush. The toilet flushes directly into the sewage holding tank (black water).

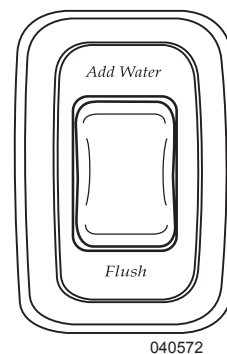
**Toilet with wall mount flush switch:**

- ◆ Press and hold the switch to the **Add Water** position until desired water level is attained.
- ◆ Press switch to **Flush** position and release to flush.

NOTE:

The toilet requires 12 Volt DC to operate. Low voltage will cause toilet malfunction or failure.

Control switches (two switches located under lid):

1. **Water Level Switch:** Adjusts the water level in the bowl after the flush cycle.

NOTE:

Setting the Water Level switch to High increases water consumption and may result in water spill during travel.

2. **Mode Switch:** Pushing the switch to Service will hold the ball valve open. This feature is useful when adding chemical to the sewage tank.

CAUTION:

To prevent accumulation of solids below toilet, add several gallons of water to the holding tank before use. Most chemical mixtures for holding tank odor control are poisonous. Follow the product manufacturer's directions and warnings when using any holding tank additive.

NOTE:

Never dispose of sanitary supplies or other non-dissolving items into the toilet. Facial tissue, wet strength tissue, paper towels or an excess toilet tissue can clog the tank or termination valve.

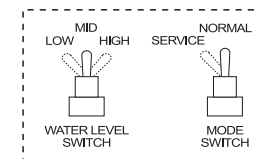

Lift lid to access control switches.

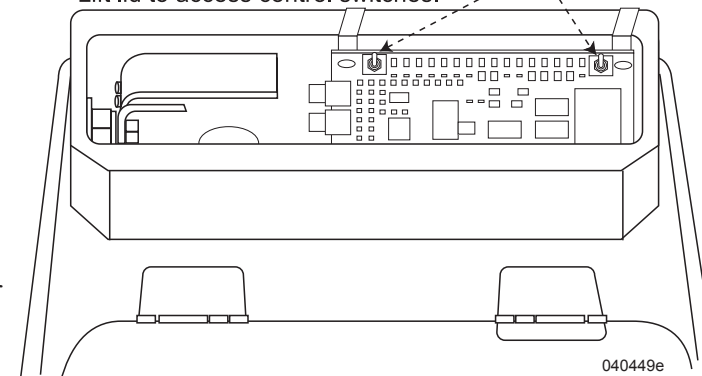

Cleaning & Maintenance

The toilet should be cleaned regularly for maximum sanitation and operational efficiency. Clean the toilet bowl with a mild bathroom cleaner. **DO NOT** use chlorine or caustic chemicals, such as drain opening types, as they will damage the seals.

Clean the toilet system using the tank flush. If additional flushing is desired, flush with several gallons of fresh water and one cup of dry laundry detergent. Add odor control deodorant, in the amount specified for the holding tank capacity, every few days during use.

Maintenance - Checking for Leaks:

◆ **Back of toilet:** Check water supply line connection. Toilet tissue works well to find leaks. The tissue changes texture when contacting moisture.

◆ Between closet flange and toilet:

Confirm that flange screws are snug. **DO NOT** over tighten screws. If leak continues, remove toilet and check flange height. Adjust the flange height to 7/16" above floor, if necessary. Replace flange seal.

Maintenance - Bowl Problems:

◆ **Poor flush:** Flush should be obtained within two to three seconds. If a problem persists, adjust the water level. If problems continue, the water pressure or flow rate may be low. Remove the water supply line and check flow rate. Flow rate should be at least ten quarts (9.5 liters) per minute. Water pressure should not be below 25 psi.

◆ **Bowl will not hold water:** Check for foreign material in ball valve.

NOTE:

If the motorhome is in storage for six months, spray silicone on the ball valve. Perform this maintenance monthly during use (silicone will evaporate in about 30 days). DO NOT use a petroleum-based lubricant, damage to the seals will occur.

Drain Traps & Auto Vents

Sinks, shower and clothes washer drains incorporate a water trap (P-Trap) and auto vents to prevent waste water holding tank odor from entering the motorhome.

Drain Traps:

P-Traps are usually within 54" of a vent tee and must contain water to block odors. During storage water can evaporate and allow odor into motorhome. If odor is detected, run water into sinks, shower and clothes washer to fill P-traps.

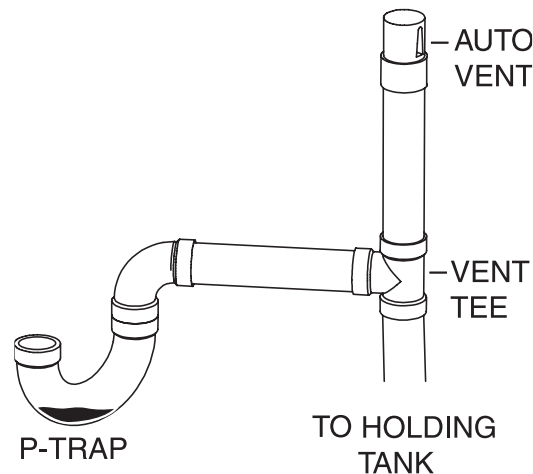

070152b

Auto Vents:

The auto vent is designed to assist in the smooth flow of water in the drain without creating a vacuum. If stuck in the open position the auto vent can allow grey odors to enter the motorhome. Some auto vents can double as “clean outs” in the event the line needs to be snaked out.

Cold Weather Conditions

Extended use in below freezing (32° F/0° C) weather will require operation of the Aqua-Hot system to protect interior water lines, fixtures, water storage tanks and pumps. Exposed drains may freeze quickly. If in doubt about what temperature the motorhome will tolerate, winterize with potable antifreeze.

Cold Weather Storage

If the motorhome is stored where freezing temperatures may occur, drain the domestic fresh water loop. Begin draining the fresh water tank by opening the low point drain for the fresh tank and allowing the water to drain.

NOTE:

Icemakers, water filters, water purifiers and the Aqua-Hot all use domestic water and should be drained and stored in accordance with the manufacturer’s recommendation for winterization.

WINTERIZATION

Water, plumbing and sewer systems require winterization when the motorhome is placed in storage. The recommended method of winterizing the motorhome is using air pressure to remove liquids that may freeze and cause damage to the various systems and appliances. The lines can then be left empty or filled with an FDA approved RV antifreeze. When plumbing lines are drained, antifreeze is not necessary, and the decision to use antifreeze is left to the motorhome operator.

NOTE:

ONLY FDA approved RV antifreeze should be used to winterize the water systems in the motorhome.

Using Air Pressure

You will need an air compressor and an adapter to connect the air line regulator to the water system. Air adapters used for winterizing are available at RV supply locations. When attached to the water lines, air pressure should not exceed 40 PSI. Higher pressure can damage the lines.

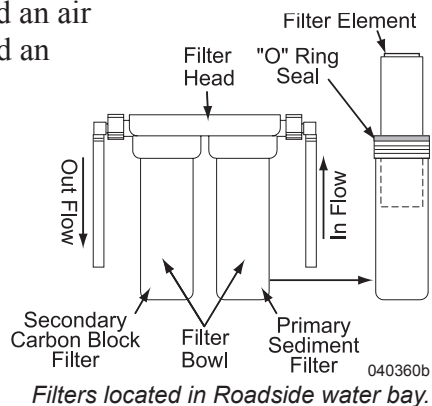

1. Empty and flush the holding tanks.
2. Drain the fresh water tank by opening the drain valve located inside the service center of the motorhome.
3. Open all low-point drain valves. Let all the water drain.

CAUTION:

Neglecting to winterize the Aqua-Hot during freezing temperatures, will result in serious damage to the domestic water heating system of the Aqua-Hot. Vehicle Systems recommends winterizing the Aqua-Hot domestic water loop with RVA approved antifreeze. Instructions for this procedure can be found in the Aqua-Hot owner's manual.

4. Locate filters in bay. Remove filters, replace canister and re-install filter bowls. Remove optional galley filters in same manner.
5. Connect an air hose with regulator to the City/Fresh Water fill connection, with valve positioned for **City Water**. Set regulator for 40 psi and turn on air. (Air adapters for winterizing are available at RV supply locations.)
6. When water stops flowing from the drain valves, open and close the faucets one at a time, hot and cold, until only air comes out. **DO NOT** forget the toilet and any outside faucets.
7. Hold the toilet flush mechanism open until the water has stopped running.
8. Disconnect the air hose with adapter and turn the City/Fresh Water valve to the **Tank Fill** position.
9. Close all valves and faucets.

10. Use one (1) gallon of FDA approved RV antifreeze to protect various water drain lines in the motorhome. Pour 1 pint into both the kitchen and bath shower drains. Pour 2 pints into the bath sink drain. This will protect the P-traps, with some of the antifreeze going into grey tank to protect the drain valve. Open the valve on the toilet. Pour another 3 pints into the toilet, letting the antifreeze run into the black tank to protect the drain valve. Use a soft cloth to wipe out the sinks, shower and toilet (after the antifreeze is poured in) to protect the surfaces from stains. Pour the last pint into the washer/dryer drain.

WARNING:

Ensure the water is not hot when opening the low-point drain lines. Hot water from the lines can cause burn injuries.

Using Nontoxic Antifreeze

About eight gallons of FDA approved RV antifreeze will be required to winterize the motorhome.

WARNING:

Use only specifically designed, non-toxic, FDA Approved RV antifreeze for potable water systems. NEVER use automobile engine antifreeze. If ingested, antifreeze can cause serious injury or death.

WARNING:

Turn off the Aqua-Hot and allow it to cool before starting winterizing procedures. Hot water can result in burn injuries. Disconnect all electrical connectors to the Aqua-Hot before winterizing.

CAUTION:

It is recommended that a qualified RV service technician familiar with motorhomes, such as an authorized dealer, perform the winterizing procedure.

1. Empty and flush the holding tanks.
2. It is not necessary to blow out the lines with air. Close valve located between water pump and fresh water tank.

CAUTION:

Ensure the fresh water tank is completely drained, as antifreeze will not enter the fresh water tank.

3. Remove water filters and re-install filter housings.
4. Close all faucets, drain valves and low point drains.
5. Turn winterizing valves at the inlet side of the water pump to the Winterize position. Set the winterizing tube into the container of non-toxic FDA approved RV antifreeze.
6. Turn on the pump.

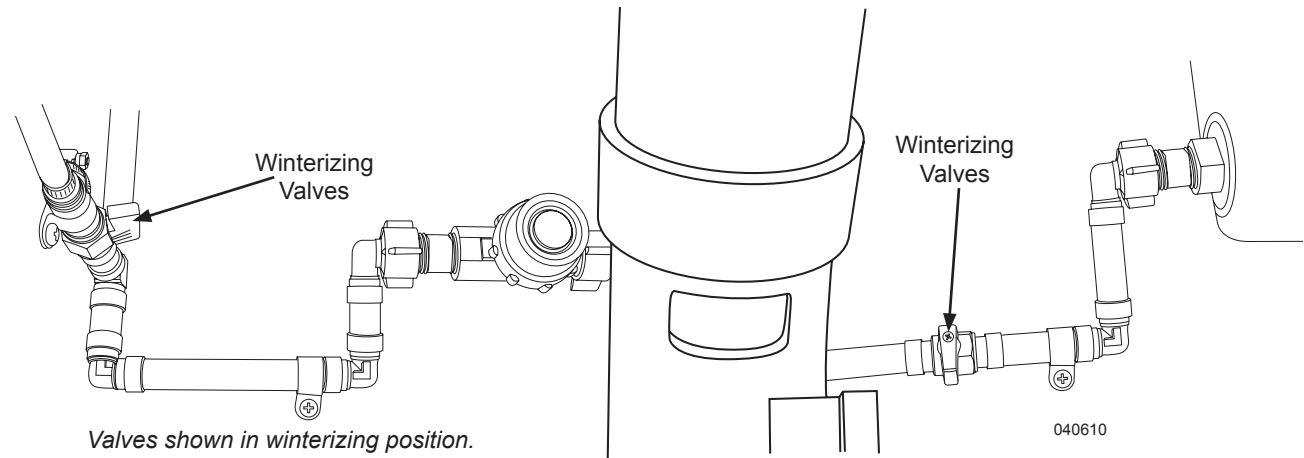

Valves shown in winterizing position.

7. Turn on all the faucets, one at a time, hot and cold, starting with the faucet farthest from the pump. When antifreeze is present, pour one cup into the drain to fill traps and turn the faucet off. **DO NOT** forget the toilet and all outside faucets.
8. Use a soft cloth to wipe out the sinks and shower to protect surfaces from antifreeze stains.
9. Disconnect the power supply line for the water pump.

NOTE:

Some items such as the icemaker, washer/dryer and dishwasher require special instructions, which can be found in the OEM manual.

NOTE:

Clean up spilled antifreeze immediately to prevent permanent staining.

De-Winterization

To de-winterize, drain and fill the fresh tank with water. Connect the power supply line for the water pump. Switch the winterizing valves back to Normal Flow position. Operate all faucets, one at a time, until clear water is present. Install new water filters.

NOTE:

The first two trays of ice from the icemaker may contain contaminants. Discard and replenish the icemaker as necessary.

SERVICE CENTER

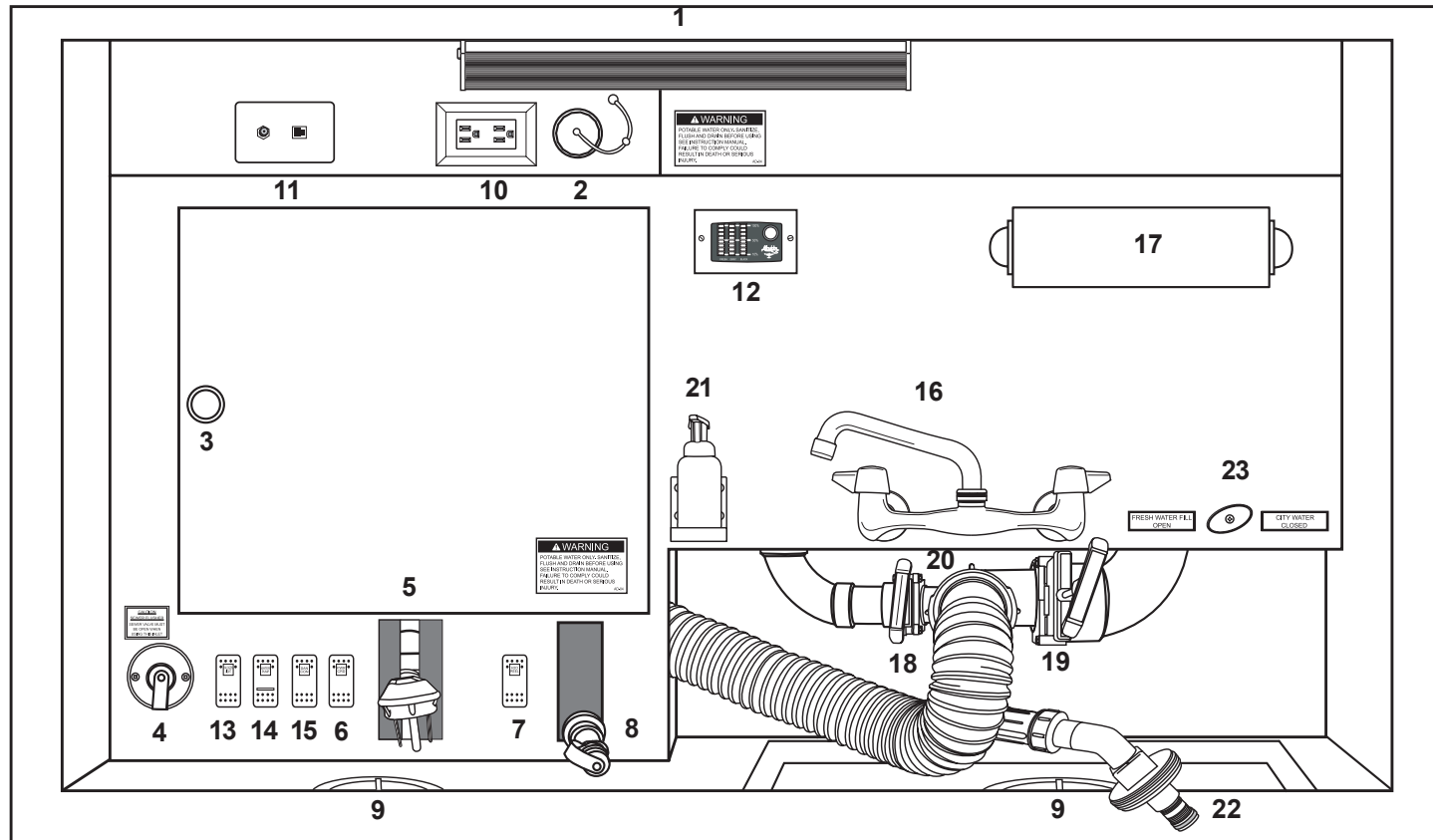

040563f

- | | | |
|----------------------------------|----------------------------------|--------------------------------------|
| 1. Service Center Light | 10. 120 Volt Outlet | 19. Black Tank Dump Valve |
| 2. Fresh Water Tank Gravity Fill | 11. Shore Cable/Phone connection | 20. Termination Outlet |
| 3. Manifold Access | 12. Aladdin Tank Monitor | 21. Soap Dispenser Holder |
| 4. Black Tank Flush Connection | 13. Service Center Light Switch | 22. Sanicon Sewer Connection |
| 5. Power Cord | 14. Water Pump Switch | 23. City Water/Fresh Tank Fill Valve |
| 6. Power Cord Reel Switch | 15. Sanicon Waste Pump Switch | |
| 7. Water Hose Reel Switch | 16. Faucet | |
| 8. Water Hose | 17. Towel Bar | |
| 9. Deck Plate | 18. Grey Tank Dump Valve | |

NOTE:

Layout of Service Center and location of components may vary with floor plans.

WATER BAY

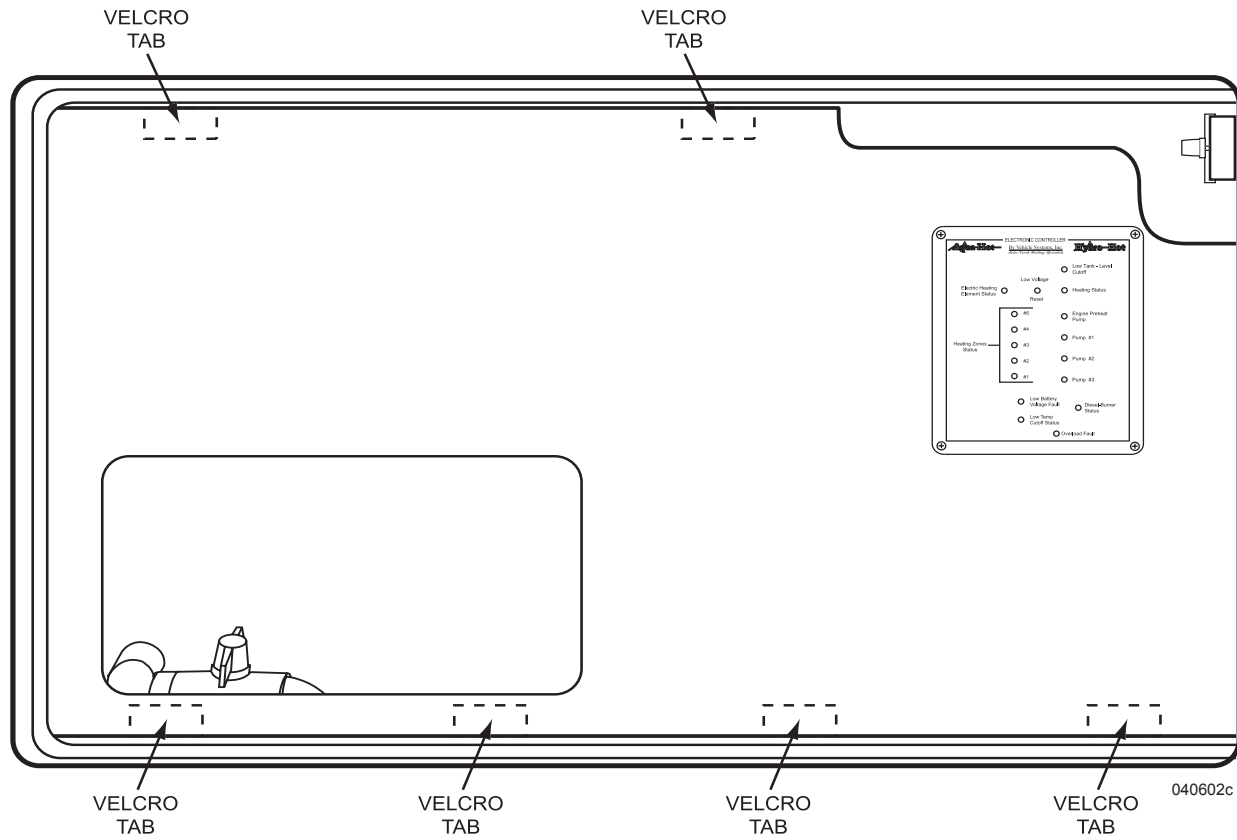

Cover Attached

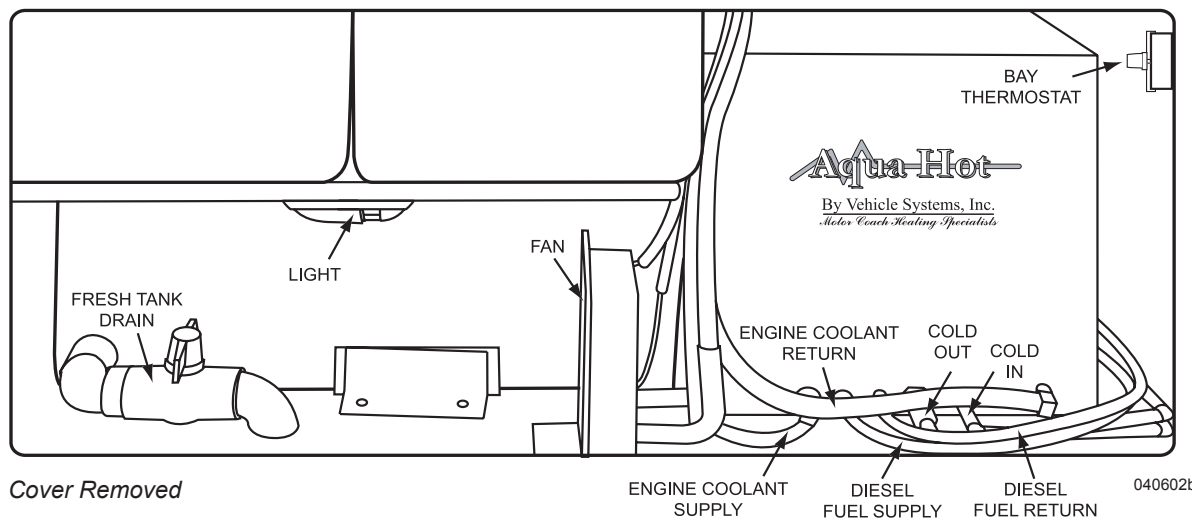

Cover Removed

NOTE:
Layout and location of Water Bay and its components may vary with floor plans.

WATER SYSTEM DIAGRAM

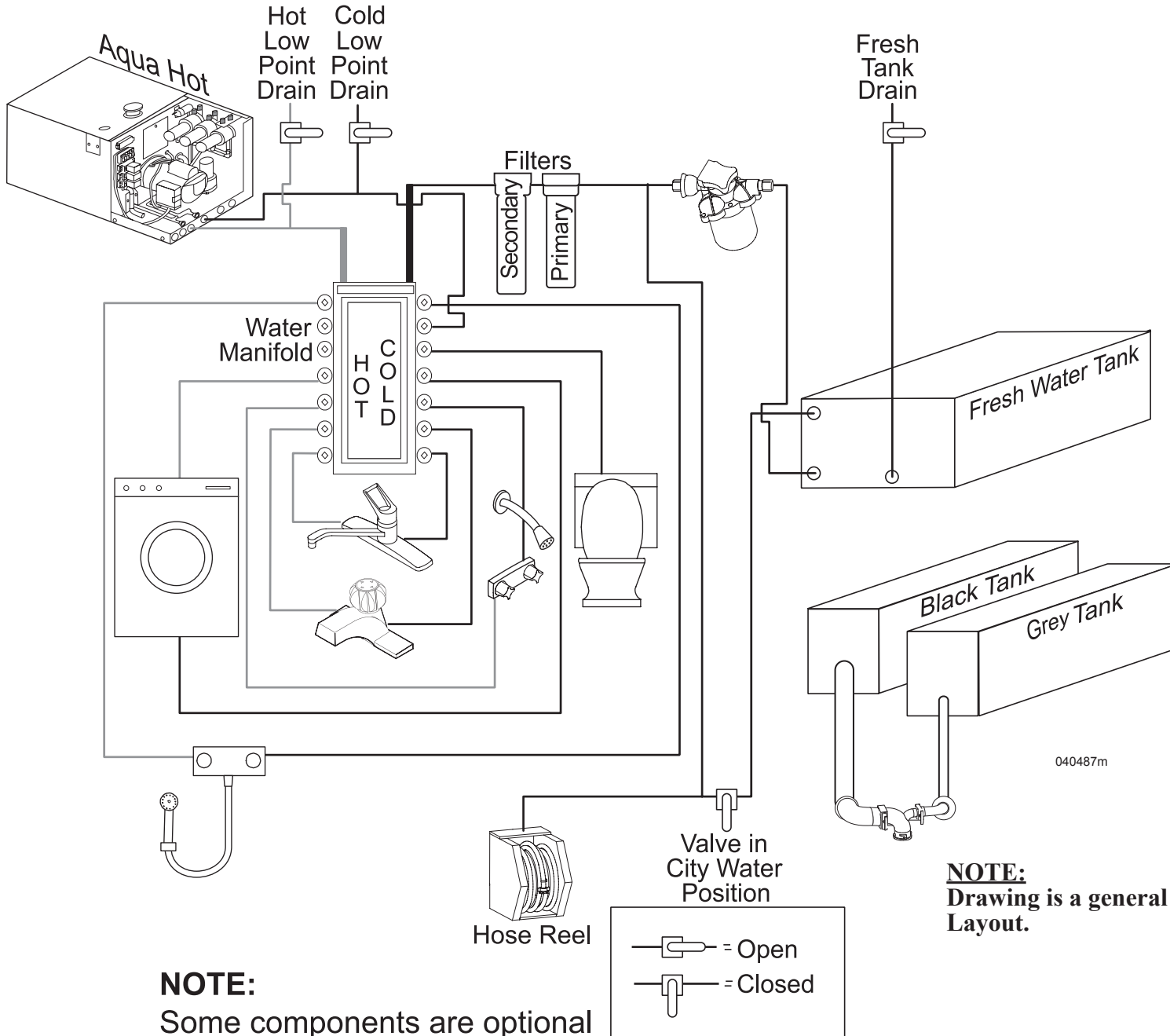

THE EXECUTIVE 07

LP-GAS SYSTEMS — SECTION 7

LP-GAS SYSTEMS.....	168
LP-GAS DETECTOR	168
Testing.....	169
Alarm.....	170
Maintenance	170
LP-GAS EMERGENCY PROCEDURES CHECKLIST	170
LP-GAS TANK	171
Measurement.....	171
Tank Capacity	171
Tank Filling	171
Tank Operation	172
Accessory Hookup.....	172
LP-GAS FUNDAMENTALS.....	172
LP-GAS REGULATOR.....	173
LP-GAS HOSE INSPECTION.....	174
LP-GAS DISTRIBUTION LINES.....	175
LP-GAS CONSUMPTION	175
LP-GAS SAFETY TIPS.....	176

LP-GAS SYSTEMS

This section contains safety information and operating instructions of the Liquefied Petroleum Gas (LP-Gas) system and related equipment in the motorhome. Some items discussed may not be applicable to all motorhomes. More detailed information with **CAUTION** or **WARNING** instructions for various equipment other than items within this section, can be found in the equipment manufacturer's manual in the owner's information box.

The LP-Gas tank mounted in the motorhome contains LP-Gas that is under high pressure. As fuel is used, the liquid vaporizes and passes through the primary tank valve to a regulator that reduces pressure. Low-pressure gas is then distributed to components through a pipe manifold system.

Component ignition problems are commonly caused by air in the manifold system or incorrect gas pressure. **DO NOT** attempt to adjust the regulator. Adjustments must be made by a dealer or an authorized service personnel with the proper equipment. In higher elevations or extreme cold weather (10° F/-12° C or lower) a shortage of LP-Gas may be experienced. If LP-Gas is going to be used in higher elevations or cold climates for a long period of time, have authorized service personnel adjust the LP-Gas regulator for these conditions.

Have the LP-Gas system tested by an authorized dealer or service center at least once a year and before every extended trip. The test will include having the system checked for leaks and the regulator pressure checked and tested for functionality. Although the manufacturer and the dealer test the system carefully for leakage, travel vibrations can loosen fittings.

WARNING:

When storing portable LP-Gas tanks that are not connected to an LP-Gas system, install an approved plug in the tank outlet hole to prevent leaks. DO NOT store or transport empty LP-Gas tanks, portable tanks, gasoline or other flammable liquids in the interior area of the motorhome. Keep open flame and spark producing materials away from the LP-Gas area. Shut off all appliances and the primary LP-Gas tank valve when the motorhome is in storage. If this warning is ignored, a fire or explosion could result.

Leaks (identified by the odor of rotten eggs or sulfur) can be easily found by applying a leak detector solution on all connections. Never light a match, have an open flame or use any spark producing equipment or appliance to test for leaks. Leaks can usually be repaired by tightening the fittings. If not, shut off the primary gas valve at the tank. Hand-tighten the primary valve only. **DO NOT** use a wrench or pliers as over tightening may damage valve seats and cause leaks. If a leak is suspected, immediately see an authorized dealer or service center for repairs.

WARNING:

LP-Gas is highly volatile and extremely explosive. DO NOT use matches or a flame to test for leaks. Only approved LP-Gas leak testing solution for leak detection should be used. Unapproved solutions can damage copper tubing and brass fittings. A liquid dish soap solution of 10 parts water may be used. Shake the solution until bubbles form and then apply the mixed solution to fittings and accessory control valves. All fittings tested should be thoroughly rinsed and dried after testing. Never attempt to adjust LP-Gas regulators. Only qualified service personnel should perform maintenance or repairs to the LP-Gas system.

NOTE:

It may be illegal to travel in some states and Canadian provinces with the primary LP-Gas valve open. Failure to comply with these State and Canadian province requirements may result in fines and/or pose a safety hazard.

LP-GAS DETECTOR

The LP-Gas detector is required safety equipment in RVs. **American National Standards Institute (ANSI) A119.2 - Fire & Life Safety 3-4.8 LP Gas Detectors** states “*A LP-Gas detector must be installed in any RV that contains an LP-Gas appliance and an electrical system. The LP-Gas detector must be listed as suitable for use in recreational vehicles under the requirement of UL 1484 Residential Gas Detectors, and installed according to the terms of its listing.*”

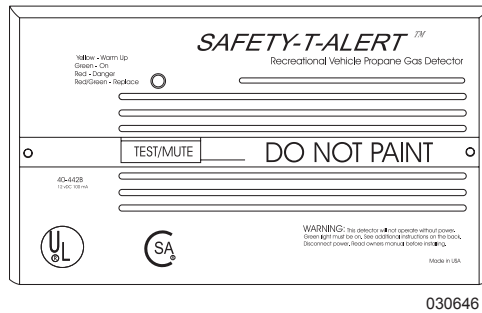

030646

LP-Gas is heavier than air and will settle to the lowest point in the motorhome. The LP-Gas detector is also sensitive to other fumes such as hair spray, of which most contain butane as the propellant. Butane, like propane, is heavier than air and will settle to the floor level. Sulfated batteries (rotten egg odor) will also sound the alarm. When this occurs, reset the detector to stop the alert sound.

About the LP-Gas Detector:

Be aware of the difference between a leak versus LP-Gas escaping from an unlit, open burner. Pure LP-Gas vapors from a leaking pipe or fitting are heavier than air and will build up heaviest concentration at the leak and float down to mix with air. LP-Gas from open burners is intentionally mixed with air to induce burning and dissipate into the air. When mixed with air, LP-Gas becomes only marginally heavier and expands outward. If a burner is left on, the area around the burner, range and adjoining counter space is combustible and can cause injury and damage when ignited. This condition will exist for an extended time period. Eventually, the LP-Gas will reach the detector's location and cause the alarm to sound.

NOTE:

The LP-Gas detector indicates the presence of LP-Gas only at its sensor. Combustible levels of LP-Gas may be present in other areas. The detector is intended for detection of LP-Gas only.

The LP-Gas detector is not designed to detect other types of gas. However, some products may cause the detector to alarm, such as alcohol, liquor, kerosene, gasoline, deodorants, colognes, propellant used in spray cans and cleaning solvents. In some cases, vapors from glue and adhesive used in the manufacturing of the motorhome may also cause the detector to alarm for several months after the date of manufacture. If it is determined that the detector has false alarmed because of the above mentioned nuisance gases, reset the detector and ventilate the motorhome with fresh outside air. Take precautions to ensure one of these cases has not masked an actual LP-Gas alarm condition.

The LP-Gas detector draws less current than one instrument panel lamp and will detect gas until the battery is drained down to 7.0 Volts. A voltage higher than 7.0 Volts is needed for the detector to operate properly. If the power source is disconnected, or if the power is otherwise interrupted, the detector will not operate.

The LP-Gas detector has a self-check circuit running at all times while the detector is powered. In the event that the circuitry fails, a failure alarm will sound and the operating indicator will cease to light.

LP-Gas Detector Operation:

Upon first application of power the LED will flash yellow for three minutes while the detector is stabilizing. At the end of the start cycle the LED will turn Green indicating full operation. If the detector senses unsafe levels of LP-Gas it will immediately sound an alarm. The LP-Gas detector draws power from the chassis batteries, with a current draw of less than 1/10th of one amp.

CAUTION:

The detector will not alarm during the three minute warm up cycle.

Testing

Press the TEST switch any time during the warm up cycle or while in normal operation. The LED will turn red and an alarm will sound. Release the switch. This is the only way to test full operation of the detector.

WARNING:

Test the operation of this detector after the motorhome has been in storage, before each trip and at least once per week during use.

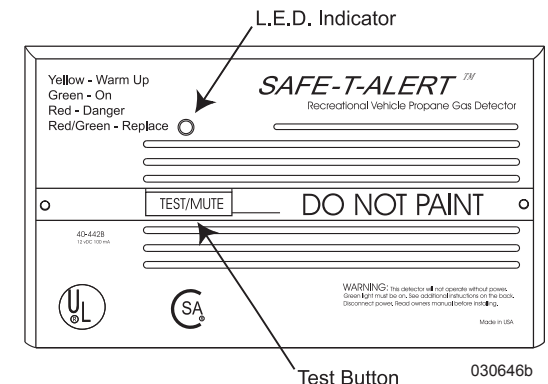

030646b

Alarm

The red LED will flash and the alarm will sound whenever dangerous levels of LP-Gas or natural gas are detected. The detector will continue to alarm until the gas clears or the **Test/Mute switch** is pressed.

Alarm Procedures:

1. Turn off all LP-Gas appliances (stove, water heater, furnace, refrigerator), extinguish all flames and smoking material. Evacuate immediately. Leave doors and windows open.
2. Turn off primary valve on the LP-Gas tank.
3. Determine and repair the source of the leak. If necessary, contact a qualified professional for service.

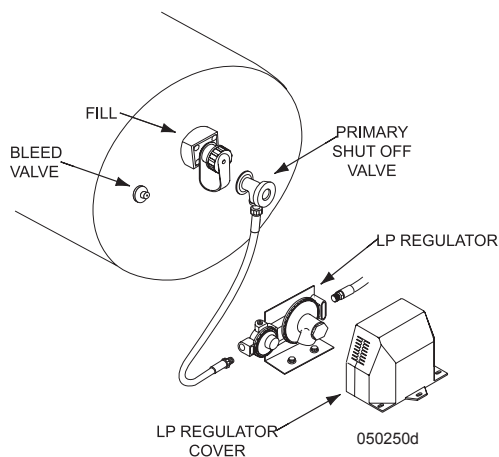

WARNING:

DO NOT operate any electric switch. This can produce a spark and ignite the gas.

CAUTION:

DO NOT re-enter until the problem is corrected.

Alarm Mute:

Press the **Test/Mute switch** when the detector is in alarm.

1. The red LED will continue to flash and the alarm will beep every 30 seconds until the gas level has dropped to a safe level.
2. The LED will flash green until the end of the Mute cycle.
3. If dangerous gas levels return before the end of the Mute cycle, the alarm will beep four times and return to phase 1.
4. After two minutes the detector will return to normal operation (solid green) or resound the alarm if dangerous levels of gas remain in the area.

Fault Alarm:

Should the microprocessor sense a fault in the gas detector, a fault alarm will sound twice every 15 seconds. The LED will alternately flash red to green and the **MUTE** switch will not respond to any command. The gas detector must be repaired or replaced.

Maintenance

1. Vacuum the dust off the detector cover weekly (more frequently in dusty locations) using the soft brush attachment of a vacuum.
2. **DO NOT** spray cleaning agents or waxes directly onto the front panel. This action may damage the sensor, cause an alarm or cause a detector malfunction.

LP-GAS EMERGENCY PROCEDURES CHECKLIST

If you smell gas (a rotten egg or sulfur smell) at any time, perform the following steps immediately:

- ◆ Shut off LP-Gas appliances.
- ◆ Manually turn off the primary shut-off valve at the LP-Gas tank.
- ◆ **DO NOT** operate any electric switch. This can produce a spark and ignite the gas.
- ◆ Open windows and doors.
- ◆ Evacuate the motorhome. Stay clear of the surrounding area.
- ◆ Keep all ignition sources out of the area.
- ◆ Contact a qualified service technician to find the source and repair the gas leak.

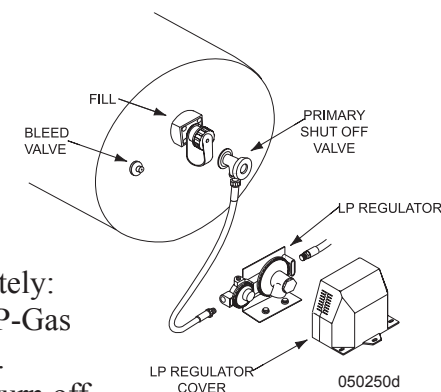

POTENTIAL SOURCES OF LP-GAS LEAKS WHEN OPERATING THE MOTORHOME

- | | |
|-------------------|---|
| ◆ Cooktop burners | ◆ Defective LP-Gas Connection |
| ◆ Oven | ◆ Defective Regulator |
| ◆ Refrigerator | ◆ Portable Propane Powered Appliances/Accessories |

WARNING:

A fire or explosion from ignited gas or gas fumes can cause serious injury or death.

LP-GAS TANK Measurement

Two methods can be used to monitor the amount of fuel in the LP-Gas tank: A small non-adjustable gauge located on the curbside of the LP-Gas tank provides a quick view of the LP-Gas level and the Aladdin™ System will also provide a percentage full reading on the COACH TANK/MISC STATUS screen.

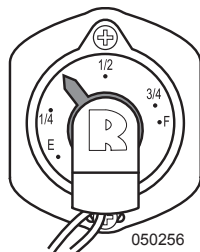

NOTE:

LP-Gas tank capacity is estimated based upon calculations provided by the tank manufacturer and represents approximate capacity. The actual “usable capacity” may be greater or less than the estimated capacity. Actual full liquid capacity is 80% of full tank capacity.

Tank Filling

Woodall’s Campground and Trailer Guide, and other similar publications, list refueling stations. Many travel parks sell LP-Gas. Before filling the LP-Gas tank, shut off pilot lights, appliances and igniters to prevent a fire or explosion. Have a trained service person fill the LP-Gas tank.

WARNING:

Before entering a refueling station, turn off all pilot lights and LP-Gas operated appliances. Most LP-Gas appliances used in recreational vehicles are vented to the outside. Fuel vapors can enter an appliance vent on a motorhome that is parked close to a gasoline pump, resulting in an explosion or fire.

WARNING:

Extinguish all sources of heat, sparks, flames and smoking materials within a 50' radius during the fueling process.

The LP-Gas tank fill is located in the roadside compartment. The tank must be filled to the proper level to allow for expansion. A tank overfilled may cause the safety valve to release pressure emitting a strong rotten egg odor near the tank and/or a hissing noise may be detected.

WARNING:

It is common for small amounts of LP-Gas to escape and evaporate during the fueling process. Protect bare skin. Instant freezing will occur if exposed to LP-Gas.

LP-Gas exists in both liquid and vapor form within the tank. A full tank is approximately 80% liquid. The pressure inside the tank varies with the temperature of the liquid. All tanks are required to have a safety pressure relief device to release excess pressure. When the tank is full, the gauge on the tank will only read 3/4. The Aladdin system is adjusted to indicate “full” at this point.

NOTE:

If the tank is new and being filled for the first time, inform the service technician to purge any air from the tank prior to filling.

COACH TANK/MISC STATUS		
FRESH TANK	PCT	XXXXXXX
	GAL	XXXXXXX
GRAY TANK	PCT	XXXXXXX
	GAL	XXXXXXX
BLACK TANK	PCT	XXXXXXX
	GAL	XXXXXXX
LP TANK	PCT	XXXXXXX
BASEMENT TEMP	F	XXXXXXX
OUTSIDE TEMP	F	XXXXXXX

0202199

Tank Capacity

LP-Gas Tank Capacity
*25 Gallons
<i>*Actual filled LP-Gas capacity is 80% of listing due to safety shut-off required on tank.</i>

NOTE:

This chart reflects product specifications available at the time of printing.

Tank Operation

- Manually open the primary shut-off valve located on the LP-Gas tank.
- Turn off the primary valve on the LP-Gas tank when the tank is being filled, when driving, in between trips and when in storage.
- Hand-tighten the primary valve only. **DO NOT** use a wrench or pliers. This will over-tighten the valve. The primary valve is designed to be closed by hand. Over-tightening may permanently damage the valve seat.

NOTE:
In some States and Canadian provinces, it may be illegal to drive the motorhome while primary valve on the LP-Gas tank is open.

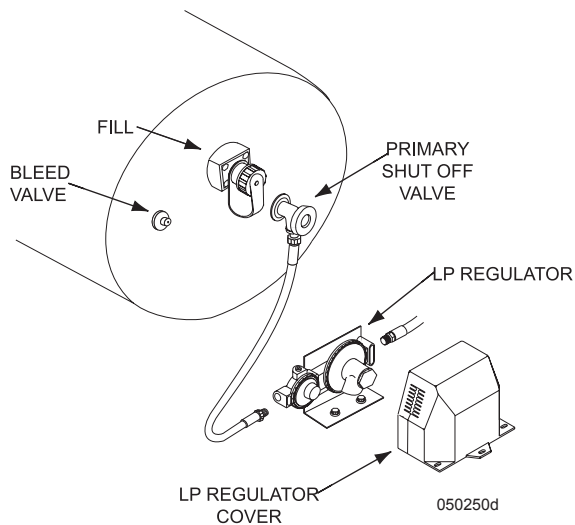

Accessory Hookup

Exterior Gas Line Hookup Prep:

An auxiliary remote LP-Gas hookup is for external LP-Gas accessories and is to be used for external components only. For safety, only approved LP-Gas quick disconnect fittings and flexible hose should be used to connect external accessories to the remote hookup. A LP-Gas Quick Disconnect fitting should be installed by a qualified agency as defined in the National Fire Protection Association NFPA (Fire) 54-02 code.

NOTE:
Check for leaks on all connections each time the remote hook-up is used. If a leak is detected, turn off the primary valve at the main LP-Gas tank. Contact a qualified service center for the necessary repairs.

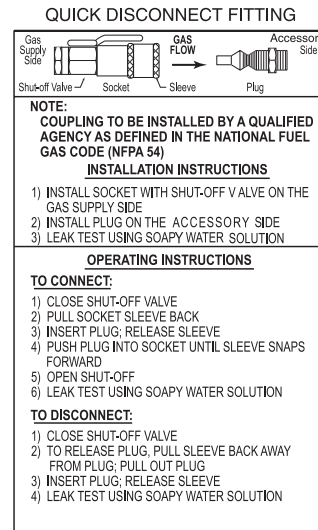

020155b

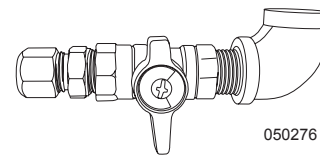

Located in the curbside bay.

LP-GAS FUNDAMENTALS

#Capacity	Gallon Capacity	BTU Capacity
5	1.18	107,909
10	2.36	215,807
11	2.59	237,387
20	4.72	431,613
30	7.08	647,420
40	9.43	863,226

The above capacities allow for 20% vapor space on each cylinder. Data taken from the National Fire Prevention Association (NFPA). Pamphlet #58-1998.

CONVERSIONS

Gallons to Liters (1 Gallon = 3.785 Liters)
Fahrenheit to Celsius ($F^{\circ} - 32 + 1.8 = C^{\circ}$)
11 in. Water Column = 6 1/4 ozs. per sq. in. pressure.
27.7 in. Water Column = 1 lb. per sq. in. pressure.

LP-Gas Statistics:

Pounds Per Gallon	4.24
Specific Gravity of Gas	1.50
Specific Gravity of Liquid	.504
Cubic Feet Gas Per Gallon of Liquid	36.38
Cubic Feet Gas Per Pound	8.66
BTU Per Gallon	91,502
BTU Per Pound	21,548
Dew Point in Degrees Fahrenheit	-44° F
Vapor Pressure at 0° F	31
Vapor Pressure at 70° F	127
Vapor Pressure at 100° F	196
Vapor Pressure at 110° F	230
Flash Point	842° F

NOTE:
LP-Gas fundamental information is not a complete guide for the use of LP-Gas tanks or appliances. In cold climates keep LP-Gas level above 50% to keep vaporization of LP-Gas at the highest level.

Basic Facts About LP-Gas:

- LP-Gas detectors are a federal requirement on all LP-Gas equipped recreation vehicles.
- LP-Gas is a by-product produced by refining oil.
- Odor is added to LP-Gas after the refining process.
- Each liquid gallon of LP-Gas produces 91,502 BTU (British Thermal Units).
- Temperature affects pressure of LP-Gas. Internal tank pressure can exceed 200 psi.
- Tanks or valves contain pressure relief valves. The relief valve opens at 125% above tank rating.
- LP-Gas stops vaporizing at -44° F.
- Standard LP-Gas operating pressure is 11" of Water Column or approximately 6 1/4 ounces per square inch.
- An inch of Water Column is a measurement of applied pressure to one side of a U-Tube 1/2 filled with water at sea level. The amount of pressure required to raise the water level 11", represents 11" of Water Column.

LP-GAS REGULATOR

LP-Gas is compressed into liquid form in the tank. Only the vapor is used during combustion by an appliance. As vapor is removed from the tank, the remaining liquid will vaporize to maintain pressure that is removed during consumption. This process will continue until there is no liquid remaining in the tank.

Temperature affects the vaporizing action of the liquid. If temperature of the liquid is - 44° F, the liquid remains stable with tank pressure, about 0 psi. If liquid temperature is 100° F, the liquid quickly vaporizes with tank pressure, about 200 psi. Vapor pressure must remain relatively consistent, regardless of temperature, for the appliance heat output to remain stable. Vapor pressure regulation is performed by the regulator.

The two-stage regulator reduces vapor pressure so that it is safe for use. The first stage of the regulator reduces tank pressure to a range of 10 to 13 psig (pounds per square inch gauge). The second stage further reduces pressure to a working pressure of 0.4 psig (11 Inches of Water Column or about 6¼ ounces psi.). A vent is installed to allow the internal diaphragm to move with atmospheric pressure change. It is important to keep the vent clean and clear of obstruction or corrosion. If the vent becomes clogged, pressure from LP tank may cause erratic pressure regulation. If there is any corrosion, contact a qualified LP-Gas service technician. The regulator is mounted so that the vent faces downward. If the vent becomes clogged, clean it with a toothbrush.

Under normal atmospheric conditions an LP-Gas regulator will not freeze, nor will the LP-Gas. Vapor passing through the regulator will expand and cool, condensing moisture in the gas. The moisture will freeze, build up and block the vent. The possibility of freeze up is greatly reduced with the two-stage regulator.

To Prevent Freeze Up:

- ◆ Ensure the LP-Gas tank is totally free of moisture prior to filling.
- ◆ Ensure the tank is not overfilled.
- ◆ Keep the valve closed when the tank is empty.

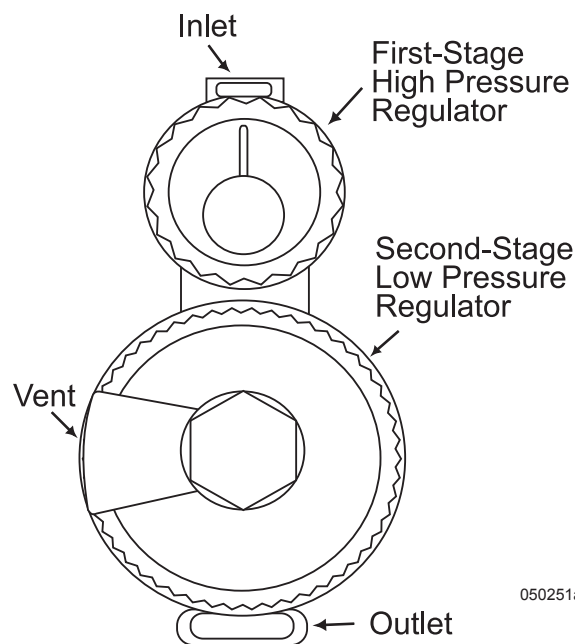

050251a

If A Freeze Up Occurs:

- ◆ Have an LP-Gas distributor purge the tank.
- ◆ Have the LP-Gas distributor inject methyl alcohol in the tank.

Damage to the regulator can occur when the tank is overfilled. The regulator is designed to work with vapor only. This is why the tank is filled to only 80% of its liquid capacity. The other 20% allows for vaporization of the liquid. The primary vapor valve is located in the vapor section of the tank. In an overfilled tank, liquefied petroleum can fill the regulator. Vaporizing liquid can freeze the diaphragm. High tank pressure on a frozen diaphragm can cause a rupture and result in erratic pressure regulation. This is why it is important to have the LP-Gas pressure checked for proper pressure and accurate regulation during appliance operation. Erratic pressure regulation dramatically affects refrigerator operation on LP-Gas.

WARNING:

DO NOT attempt to adjust the regulator. Adjustments require special equipment. Failure to follow these instructions may result in a fire or explosion, and can cause severe personal injury or death. DO NOT operate LP-Gas appliances until the LP-Gas pressure is checked and a leak down test is performed!

Manometers:

The manometer is the best way to accurately determine LP-Gas pressure. There are two different styles of manometers: Gauge and U-tube. Gas pressure is measured in Inches of Water Column. This is the amount of pressure applied to one side of a U-shaped tube half filled with water. The amount of pressure needed to raise the column of water 11" represents 11 Inches of Water Column.

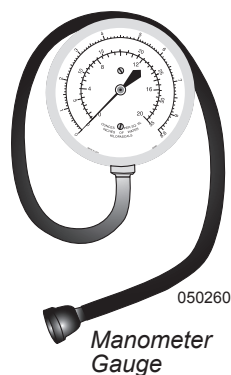

Manometer Gauge

TIP:

Attach the manometer gauge to the accessory hookup line to avoid loosening any interior LP-Gas line connections.

LP-GAS HOSE INSPECTION

It is suggested by the hose manufacturer that a flexible LP-Gas supply hose undergo regular inspection. As a guideline, we suggest that all flexible LP-Gas lines connecting the slide-out, appliances and tanks be inspected in the spring and fall of each year by a qualified RV technician.

Inspection tips:

Hose strength is controlled by the plies of reinforcement. Damage in this area cannot be tolerated. It is important that if a damaged LP-Gas hose is found, the source of the damage be determined and corrected prior to the replacement. Small cuts, nicks, or gouges that do not go completely through the cover are not cause for replacement of the hose. Inspection should be performed when the hose is not under pressure.

NOTE:

Pricking of the cover in the manufacture of this type of hose is common and necessary for satisfactory hose performance. Consequently, the uniformly pricked cover should not be viewed with alarm.

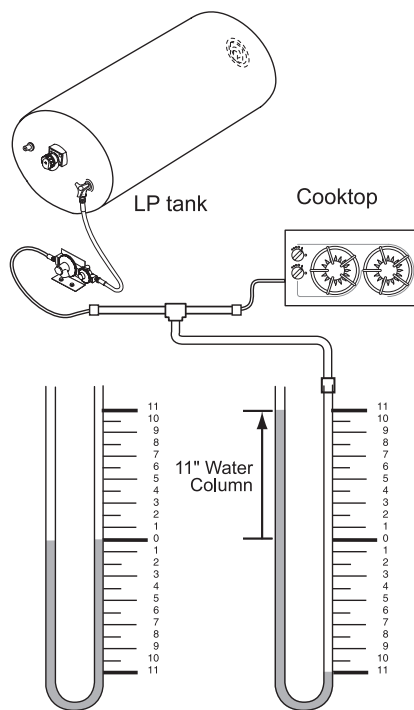

U-Tube Testing Layout

Cause for hose replacement:

- ◆ Damage to the textile reinforcement or wire braid; wire braid reinforced hose, which has been kinked or flattened so as to permanently deform the wire braid in the un-pressurized state.
- ◆ Blistering or loose outer cover.
- ◆ Slippage; evidenced by the misalignment of the hose and coupling and/or the scored or exposed area where slippage has occurred.

NOTE:

Only a qualified RV service technician should complete replacement of LP-Gas components.

Additional suggested maintenance:

After performing extensive testing the manufacturer of the flexible LP-Gas supply hoses has determined that the hoses be replaced every ten (10) years as the failure rate may increase after this period of time. The motorhome manufacturer recommends following this guideline to assure continued safety and dependable use.

LP-GAS DISTRIBUTION LINES

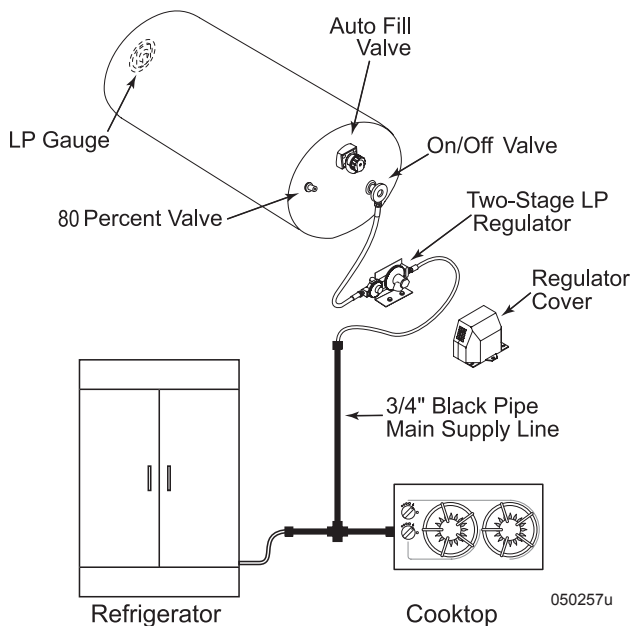

A primary manifold black steel pipe running throughout the motorhome distributes LP-Gas to secondary lines. All secondary lines leading to gas appliances are made of copper tubing with flared fittings. It is recommended that gas distribution work be performed by an authorized dealer or an authorized service technician.

INSPECTION:

Inspect the rubber flexible lines twice a year for abrasions, tears, kinks or other signs of damage.

If a gas leak is suspected, have the system inspected and repaired by a qualified service technician as soon as possible.

LP-GAS CONSUMPTION

Each gallon of LP-Gas produces 91,502 BTUs of heat. One 27 gallon tank produces two million BTU's. Total consumption depends on the rate of usage by each appliance and the operating time. The stove typically uses the most LP-Gas.

Determine Fuel Consumption:

To determine approximately how many hours an LP-Gas appliance will operate on one gallon of LP-Gas, use the following formula:

- ◆ LP-Gas appliances are rated in Input BTU (British Thermal Units). The rating is usually stamped or printed on a tag affixed to the appliance. For example: the Input rating of the appliance is 10,000 BTUs.
- ◆ One gallon of LP-Gas produces 91,502 BTUs.
- ◆ Divide the amount of BTUs of one gallon of LP-Gas (91,502) by the rating on the appliance in this example 10,000. Net continuous operation time for one gallon of LP-Gas for this appliance would be approximately 9.2 hours.

Typical Appliance BTU Ratings

Cooktop

Large - 9,500 BTU
Small - 6,500 BTU

Refrigerator (Norcold)

4-door - 2,200 BTU

The above formula can be useful when trying to determine the approximate length of time a tank of LP-Gas will last. Generally, LP-Gas appliances do not continuously operate. An example would be the typical cycling of the refrigerator.

Determining how long a tank of LP-Gas will last:

- ◆ Combine the BTU input totals of all appliances, and the approximate length of time these appliances operate per day.
- ◆ Multiply the number of liquid gallons in the LP-Gas tank by 91,502.
- ◆ Divide the total of BTUs of the LP-Gas tank by the total number of BTUs the appliances consume, equals the approximate number of hours of operation before refueling.

WARNING:

LP-Gas is highly volatile and extremely explosive. Never use matches or open flame to test for leaks. Use only approved LP-Gas leak testing solution to test for leaks. Unapproved solutions can damage copper tubing and brass fittings. Never attempt to adjust the LP-Gas regulator without the use of proper equipment. Improper LP-Gas regulator adjustment will affect the performance of LP-Gas operated appliances. Incorrect flame or explosion can occur. Only qualified personnel should perform any maintenance or repair to the LP-Gas system.

LP-GAS SAFETY TIPS

LP-Gas is one of the safest and most reliable fuels available on the market when handled properly. LP-Gas, however, does have a great explosive “potential” if handled improperly. Danger is minimized by becoming familiar with and following a few safety precautions, and by learning how to properly operate LP-Gas appliances. Use of LP-Gas requires the responsibility to enforce extra safety measures.

The motorhome is equipped with many LP-Gas operated appliances because it is a convenient and efficient source of fuel. LP-Gas appliances must be operated and maintained in accordance with the product manufacturer’s instructions.

The National Propane Gas Association (NPGA) has a special service program offered called GAS® (Gas Appliance System) Check. The GAS® Check program is aimed at educating users about the convenience of propane with safety and peace of mind. For information on the **NPGA Gas® Check program**, call **(202) 466-7200** or visit **www.npga.org**.

Maintenance and Safety Tips for the LP-Gas Refrigerator:

- ◆ Have the refrigerator venting inspected annually by an authorized server center.
- ◆ Before firing up the refrigerator for the first time each season, have the venting system checked for blockage. Insects may have built nests that will obstruct flow.
- ◆ At the first indication of incomplete combustion (yellow flame instead of a blue flame or soot is present) contact a service technician immediately. Improper combustion can cause carbon monoxide buildup, which is potentially fatal!

Maintenance and Safety Tips for the LP-Gas Range:

- ◆ Burner flame should be a blue color, indicating complete combustion. If not, have the unit serviced by a qualified technician.
- ◆ **DO NOT** cover the oven bottom with foil. Air circulation will be restricted.
- ◆ Never use LP-Gas ranges or ovens for heating purposes.
- ◆ Always have pot handles turned inward.
- ◆ Ensure children understand never to turn or play with the knobs on the front of the LP-Gas range.

THE EXECUTIVE 07

ELECTRICAL SYSTEMS - HOUSE – SECTION 8

HOUSE ELECTRICAL - INTRODUCTION	178	DISTRIBUTION PANELS - HOUSE 120/240 VOLT AC	187
BATTERY DISCONNECT - HOUSE	179	Circuit Breaker	187
BATTERY CUT-OFF	179	GFCI BREAKERS & OUTLETS	188
MASTER OFF SWITCH.....	180	DISTRIBUTION PANEL - HOUSE 12 VOLT DC ..	188
SHORE POWER HOOK-UP	180	FUSES.....	189
Power Cord Reel	182	BATTERIES - HOUSE	189
120 Volt AC & Amp Display.....	182	Battery Maintenance	190
TRANSFER SWITCH	183	Testing the Battery	191
GENERATOR - 120/240 VOLT AC	183	Battery Charge Time & Consumption Rate ..	192
Pre-Start Checks.....	183	SOLAR PANEL (OPT).....	193
Starting the Generator	184	Charge Controller	193
Stopping the Generator.....	184	Solar Panel Care	193
Powering the Equipment.....	184	LIGHTS.....	194
Generator Fuel.....	185	Interior Halogen.....	194
Resetting the Circuit Breaker.....	185	Map Lights.....	194
Generator Exercise	185	BULB USAGE – INTERIOR	194
INVERTER	185		
Providing AC Power with Inverter.....	185		
Battery Charging with the Inverter.....	186		
Auto Generator Start	186		
Factory Default Settings	187		
Battery Temperature Sensor	187		

HOUSE ELECTRICAL - INTRODUCTION

This section contains guidelines, procedures and information that will assist in understanding the domestic electrical system and the operation of various components. Refer to the OEM manuals included in the Owner's Information File box for their respective, in-depth, individual component operating instructions.

General Overview:

The motorhome can utilize various sources of electrical power: shore power connection, generator, inverter, solar panels, chassis batteries and domestic batteries. All of these electrical power sources, while independent of each other, can be combined in a variety of ways to provide a highly efficient electrical operating system. Two types of electrical systems are used: 120/240 Volt AC and 12 Volt DC.

The motorhome 120/240 Volt AC system can be operated from three different power sources: shore power, the on-board generator or the inverter/charger. Shore power is the most efficient and should be used whenever possible. The generator can be used when shore power is unavailable. The inverter/charger supplies silent AC power using the house batteries of the motorhome. However the inverter/charger AC power output is limited and should be used sparingly to conserve house battery power.

Two different sources supply the main AC circuit breaker panel with power: the 50 Amp shore power cord or the on-board generator. The power source used is automatically selected by a switching device known as a transfer switch. The inverter supplies AC power to the sub-panel.

WARNING:

The electrical system is engineered and tested for complete safety. Circuit breakers and fuses protect the electrical circuits from overloading. When planning modifications or additions to the electrical system, we strongly recommend consulting a dealer for assistance to ensure continued integrity and safety of the electrical system. Please note that any modifications may void the warranty.

WARNING:

Water is electrically conductive. Do not use any electrically powered item or electrical outlet that may be exposed to a water source. Such use can result in a serious shock causing injury or death.

The motorhome has two 12 Volt DC systems: chassis and house. These two systems, for the most part, are separate from one another. The house system does not operate engine functions; the engine system does not operate house functions. However, within the two systems there are some inner connections. **For example:** While the motorhome is driven the alternator on the engine will charge the house batteries. Likewise, while the motorhome is plugged into shore power, or the generator is running, the engine batteries are being charged. Each system will supply 12 Volt DC power to the 12 Volt DC distribution panels.

The chassis and house systems have their own sets of batteries. The chassis batteries supply 12 Volt DC power to the front distribution panel located outside in the front roadside bay. This panel contains mostly engine system circuits and wiring such as headlights, taillight, dashboard

functions, gauges, etc. The house batteries supply 12 Volt DC power to the distribution panel located in the bedroom. This panel contains fuses for the house, interior lighting and appliances. Become familiar with these panels and the items they operate.

With all the technological advancements taking place in the past several years manufacturers have now incorporated electronics into these systems. It is important to keep the 12 Volt DC systems in good working order. These systems, with their incorporated electronics, are voltage sensitive. Some items can be damaged if the DC voltage is not maintained within the designed specifications.

A majority of the lighting and appliances are designed to operate from 12 Volt DC (direct current) power. This is why the batteries play such an important role in the function of the motorhome. There are exceptions with appliances such as the microwave or television; however, indirectly they still operate from 12 Volt DC power, as they can be operated from the inverter. The chassis functions (engine, transmission, dash air, etc.) are also 12 Volt DC.

Shore Power:

The motorhome is equipped with a shore power cord to connect the motorhome to outside electrical services. Shore power service is the most efficient source of electrical power. The plug end of the shore power cord is 50 Amp, 240 Volt AC. When this type of power service is not available, electrical adapters are required to allow a proper and safe connection to the electrical service supply.

NOTE:

When 50 Amp shore service is not available, care will have to be used when operating the appliances and using the outlets to avoid overloading the shore power service.

Generator:

The generator can be selected for use when shore power is unavailable. The maximum amount of generator output power, measured in watts, is calculated at an elevation of 500 feet above sea level. This figure will decrease slightly at higher altitude. Ambient temperature also effects total maximum output. The amount of AC electrical load applied to the generator determines fuel consumption.

Inverter/Charger:

The Inverter/Charger is an auxiliary 120 Volt AC power source that inverts 12 Volt DC house battery power to 120 Volts AC. This device has limited AC power output, measured in watts, and operates only selected appliances and outlets. The Inverter/Charger also converts 120 Volts AC power, supplied from either shore power or the generator, to 12 Volts DC power, to recharge the batteries. When dry camping, the Inverter/Charger may be used to supply power to selected outlets.

BATTERY DISCONNECT - HOUSE

The main house battery disconnect switch turns the house battery power supply on or off by disconnecting 12 Volt DC power to the following items: inverter, domestic fuse panel in the bedroom, domestic fuse panel in the front run box and domestic power supply in the rear run box(s). Turn the house battery disconnect switch off when the motorhome is going to be stored for more than 48 hours or before performing electrical maintenance. If possible, leave the motorhome plugged into outside electrical service with the battery disconnect switch on to help prevent the possibility of dead batteries. Use of this battery cut-off switch will not turn off all DC electrical items or other parasitic loads present on the house battery. Some are federal mandate items such as the LP-Gas detector.

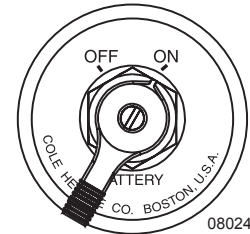

Located in the curbside battery compartment.

NOTE:

The optional solar panel will charge the batteries with the disconnect switches off.

BATTERY CUT-OFF

The battery cut-off switch is located inside the motorhome next to the entry door. This switch controls the 12 Volt DC power to the domestic fuse panel and Multiplex System. The switch locks into the center position to prevent interior DC power from being accidentally turned on or off. When the switch is activated, power is supplied to all interior DC lighting and DC operated appliances. Some appliances will require both DC and AC power to operate, such as the roof air conditioner. This switch is helpful when dry camping to conserve house battery power. Refrigerator and inverter operation are unaffected by the use of this switch. When the interior house power is off there are still parasitic loads on the house batteries; therefore, it is not a substitute for the main battery disconnect switch.

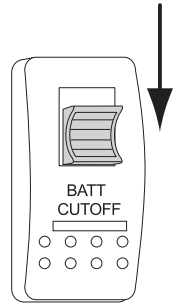

080375d

Release Lock

To Turn the Interior Power ON or OFF:

- ◆ Simultaneously push the spring-loaded lock down and push the switch.

CAUTION:

Avoid flash damage to electrical contacts. Turn off the interior lighting before operating the battery cut-off switch.

MASTER OFF SWITCH

The Master Off switch has two functions; one function turns backlighting on and off on Multiplex switches, and the other function turns off electrical items (mostly interior lighting) that operate using Multiplex switches. A Master Off switch is located on the bedroom panel.



To Turn Backlighting Off/On:

- ◆ Momentarily press the Master Off switch.

To Turn Off the Multiplex System:

- ◆ Press and hold the switch for three seconds.

SHORE POWER HOOK-UP

The power requirement for the motorhome is 30 Amp 120 Volt AC or 50 Amp 240 Volt AC single phase. The shore cord is stored in the roadside compartment at the plumbing service center. If 50 Amp shore power service is available, connect the supplied shore power cord. If less than 50 Amp service is available, electrical adapters will be required.

CAUTION:

Avoid flash damage to the electrical system contacts. Before plugging the motorhome into shore power, starting the generator or using the inverter make sure all the appliances are off.

WARNING:

Keep fingers away from metal contacts of the shore plug end. Do Not stand in water when making electrical connections. Serious electrical shock and personal injury can occur. To avoid the risk of electrical shock, turn the circuit breaker off at the power supply outlet before making the shore power connection.

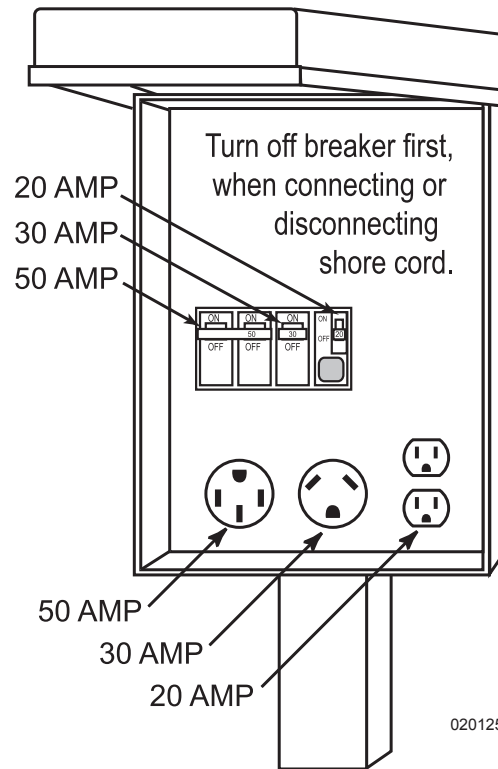

Typical Power Pedestal

CAUTION:

DO NOT remove cover from shore power supply to troubleshoot electricity to the motorhome. Serious personal injury or death may occur. If there is no power to the motorhome inform the park manager. It is the park manager's responsibility to fix problems with the shore power pedestal.

Plugging in Shore Cord with Power Cord Reel:

- ◆ Located in the roadside compartment is the shore power cord.
- ◆ Locate the power cord switch. Extend the cord by placing the switch to the **OUT** position. Extend a sufficient amount of cord to reach the power supply, then turn the switch off. If 50 Amp service is not available, install the proper electrical adapter(s) to the cord.
- ◆ Always turn **OFF** the shore power breaker at the power supply, before connecting or disconnecting the shore cord to avoid an accidental shock or flashing of electrical contacts.

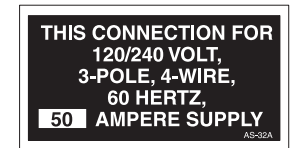

060203

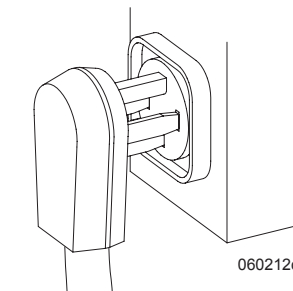

060212c

- ◆ After the connection is made, turn the shore power breaker on. The transfer switch should make an audible click.
- ◆ Check for AC voltage using the Aladdin screen.

Disconnecting Shore Cord:

- ◆ Turn off all AC appliances. This will prevent accidental shock and flashing of electrical contacts when disconnecting.
- ◆ Turn off the shore power breaker.
- ◆ Grasp housing of electrical cord. Without touching electrical contacts, work cord out and away from socket.
- ◆ Straighten and clean cord.
- ◆ Stow in compartment by placing the switch in the **IN** position.

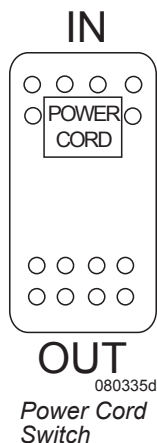

CAUTION:

If shore power service is limited to 15 or 20 Amps, use of light duty extension cords and electrical adapters will create voltage loss through the cord and at each electrical connection. Line voltage loss and the resistance at each electrical connection can be a hazardous combination. Damage to sensitive electronic equipment may result.

WARNING:

Avoid the risk of electrical shock or component damage by disconnecting from shore power during electrical storm activity. Use the Inverter/Charger or start the generator if AC power is needed.

Power Supply:

Amperage supplies vary greatly depending on the amount of available current.

- ◆ The continuous amount of current through a breaker or fuse is only 80% of its rated capacity.
- ◆ 50 Amp 240 Volt AC shore power service consists of two power supply conductors, a neutral and a safety ground. The 50 Amp breaker simultaneously limits each power supply conductor to no more than a short-term maximum of 50 Amps for each conductor. The 50 Amp 240 Volt AC service actually provides 80 continuous amps.
- ◆ Use care when hooked to anything less than 50 Amp shore service. Shore power service less than 50 Amps consists of one power supply conductor, a neutral and a safety ground; 30 Amp shore service is limited to 24 continuous Amps; 20 Amp shore service is limited to 16 continuous Amps.

When Hooked to 50 Amps:

After verifying proper voltage, wait approximately one minute for the inverter/charger to stabilize charging of the batteries before starting air conditioners or other large AC loads.

When Hooked to 30 Amps:

If 50 Amp service is not available, wait approximately one hour before operating electric appliances. Use caution when operating appliances to avoid overloading the supplied shore service breaker. Operate appliances and outlets in sequence rather than all at the same time.

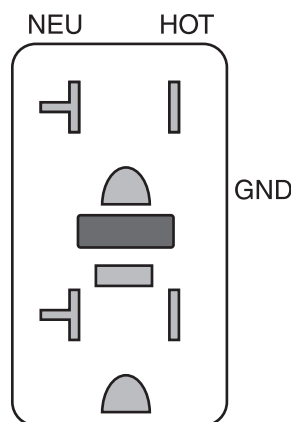

15-20 AMP
120 VOLT AC

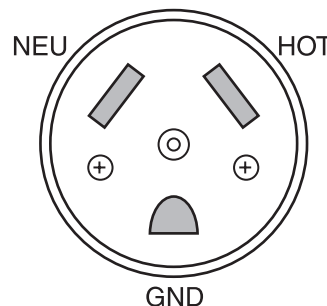

30 AMP
120 VOLT AC

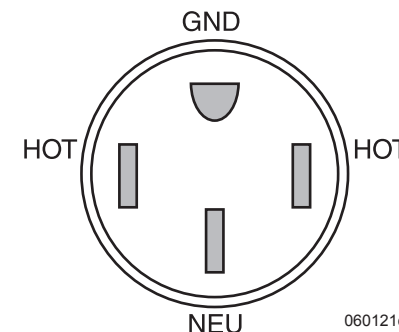

50 AMP
240 VOLT AC

Electrical Adapters:

There are different electrical adapters to suit a variety of needs. Only UL approved adapters should be used. The most common adapter is a 50-30 Amp adapter. This type of connector adapts the 50 Amp shore cord to a 30 Amp shore power outlet. Another common adapter is the 30-20 Amp adapter. Always install the adapter to the cord prior to making the connection to the outlet.

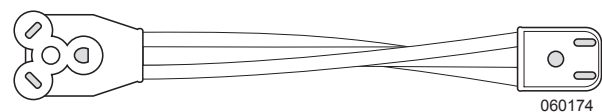
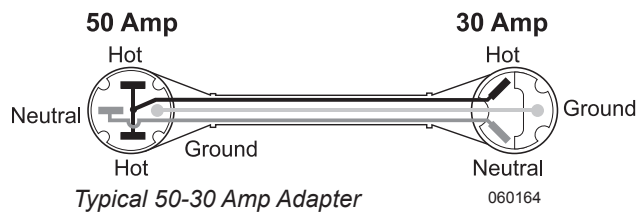

Typical 30-20 Amp Adapter: Adapts 30 Amp Shore Cord to 20 Amp Shore Power Outlet

Power Cord Reel

The Power Cord reel is a 12 Volt DC motorized assembly designed to mechanically coil and stow the shore cord. The power cord reel is located in the roadside compartment of the motorhome. The power cord switch operates a 12 Volt DC motor that extends and retracts the cable.

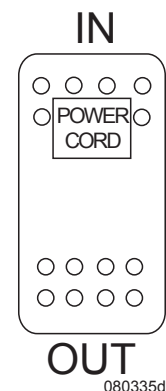

Power Cord Switch located in service bay.

When extending or retracting the power cord, turn the switch to the direction desired. Assist the cord, following the direction of travel. Extend only as much power cord as necessary to reach the shore power outlet. When the cord is connected to shore power, it should be slightly slack.

Maintenance:

When only a short section of the shore power cable is frequently used, kinks may form. To relieve kinking, routinely extend the cable full distance and straighten the power cable on the ground. It is important the cable remains clean. Accumulated dust and dirt on the cable may cause difficulty in retracting the cord. After cleaning and straightening, allow the Cablemaster to retract the cable.

Check all AC and DC wiring at least once each year to ensure corrosion-free, tight connections. Check the neoprene cover on the Power Switch to confirm it is free of cracks or fractures.

WARNING:

Before working on the electrical system, disconnect from shore power and turn off the Inverter/Charger. Disconnect the negative 12 Volt DC battery cables at the inverter. Remove rings, metal watchbands and other metal jewelry before working around batteries and connectors. Use caution when working with metal tools. If the tool contacts a battery terminal or metal connected to it, a short circuit could occur causing personal injury, explosion or fire.

120 Volt AC & Amp Display

The Aladdin™ System Coach Electrical Status screen displays AC and DC electrical values:

- ◆ AC voltage, amperage and frequency values when hooked to shore power or operating from the generator.
- ◆ House Battery DC voltage and amperage.
- ◆ Solar panel charge voltage and amperage.
- ◆ Reports the status of the Surge Guard Automatic Transfer Switch.

COACH ELECTRICAL STATUS			
	VAC	AMP	FRQ
AC LEG1	125	0.0	60
AC LEG2	125	19.0	60
SHORE POWER SELECTED			
	VDC	AMP	
SOLAR	1.0	0.0	
HOUSE BAT	12.2	0	

The Aladdin™ System monitors the two “hot” supply lines of the 240 Volt AC system. Voltage, amperage and frequency values are measured at the transfer switch. After hooking to shore power, check that incoming electrical values are satisfactory. Monitor current consumption when using appliances and hooked to anything less than 50 Amp service. AC values will read “Off” when using the inverter for AC power.

Use the Aladdin™ System to avoid low or high voltage operation and to monitor DC current consumption when dry camping.

NOTE:

When operating from the inverter, use the inverter remote display to monitor AC voltage and amperage.

TRANSFER SWITCH

The transfer switch will automatically transfer to either shore power or generator when energized. In the event both shore and generator power are available, generator power will override shore power after a 30 second delay. Once the generator is shut down, shore power will be available after a two second delay.

The transfer switch uses electronics to monitor voltage input for high or low voltage conditions. If the incoming voltage from the generator or shore power exceeds 132 AC Volts, or if voltage drops below 102 AC Volts, the transfer switch automatically disconnects electrical service to prevent damage that can occur to voltage sensitive equipment.

The transfer switch monitors for faulty wiring from the power pedestal and protects from reverse polarity and the dangers of an open neutral condition. A multi-mode surge protection eliminates the potential for power surges to enter the motorhome through power cables during electrical storms.

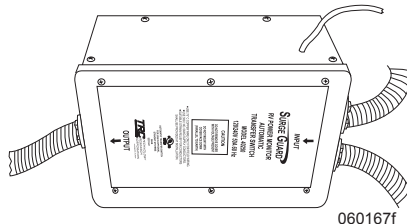

060167f
Located in pass-through storage bay.

NOTE:

To prevent damage to transfer switch contacts, discontinue appliance operation and turn off auxiliary electrical loads operated by outlets before connecting/disconnecting shore power or starting/stopping the generator.

GENERATOR - 120/240 VOLT AC

The generator is located in the front compartment of the motorhome.

The generator can be started from the following locations:

- ◆ Generator remote switch on the dash.
- ◆ Generator control panel located on the generator.
- ◆ Bedroom control panel.
- ◆ Inverter panel.

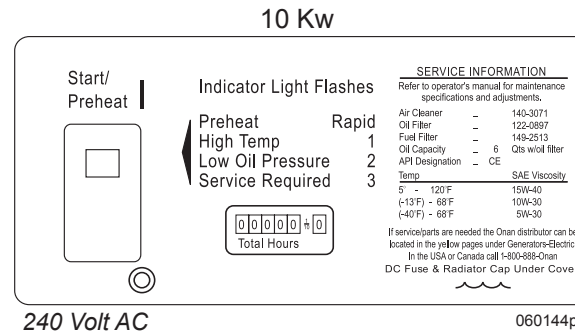

Pre-Start Checks

Prior to the first start of the day perform a general inspection including oil and coolant levels. Keep a maintenance log on number of hours in operation since the last service. Perform any service or maintenance that may be due.

WARNING:

Disable the Auto Gen Start feature before servicing the generator.

Before Starting the Generator:

- ◆ Clear people and animals from hazards of electrical shock and moving parts.
- ◆ All appliances and other large AC electrical loads must be off.

NOTE:

The generator may require priming. To prime hold control switch in the OFF position. Repeat if necessary. The diesel generator fuel pick-up tube is cut to approximately 1/4 tank so as not to run the main engine out of fuel.

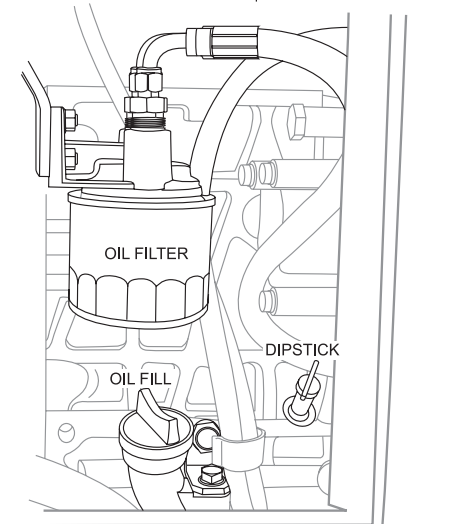
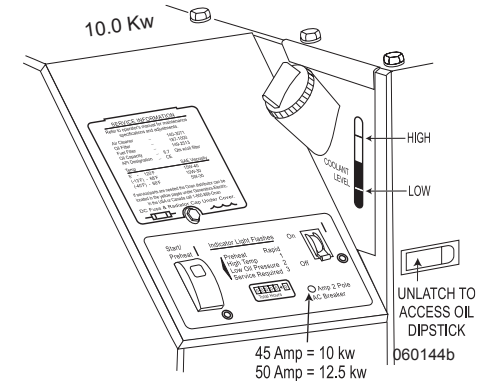

Located behind access door on generator.

Starting the Generator

Push and hold the control switch in **START** position until the generator starts. Release switch. On diesel models, the control switch may flash up to 15 seconds, indicating engine preheat.

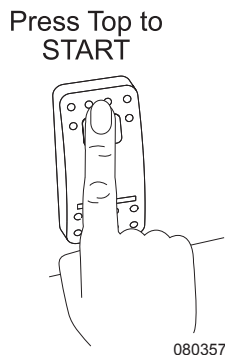

WARNING:

Excessive cranking can overheat and damage the starter motor. **DO NOT** crank the engine more than 30 seconds at any one time. Wait at least two minutes before resuming. If the generator fails to start refer to the manufacturer's manual.

WARNING:

When the motorhome is parked, position the dash air conditioner vent control in the **OFF** position to prevent exhaust gases from entering the motorhome. The engine exhaust contains carbon monoxide, which is an odorless and colorless gas. Carbon monoxide is poisonous and can cause unconsciousness and/or death. Inspect the exhaust system thoroughly before starting the generator. **DO NOT** block the exhaust pipe or situate the motorhome where the exhaust may accumulate either outside, underneath, or inside the motorhome or any nearby vehicles. Operate the generator only when safe dispersion of exhaust can be assured. Monitor the outside conditions to be sure that the exhaust continues to disperse safely.

WARNING:

When parking near high grass, hot exhaust pipe or hot exhaust gases can ignite the grass.

CAUTION:

An exhaust extension adds weight and stresses the generator exhaust system. Damage to the exhaust piping or exhaust manifold can result allowing Carbon Monoxide gases to accumulate under or leak into the motorhome.

Stopping the Generator

Turn off the appliances and disconnect other AC loads being used. Allow the generator to run unloaded for at least one minute before shutdown to allow the engine to cool. Momentarily push the control switch to the **STOP** position. Release the switch.

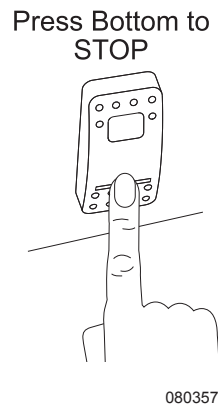

NOTE:

The generator requires only a momentary stop signal.

Powering the Equipment

The AC output of the generator powers the motorhome air conditioners, the AC Inverter/Charger and all appliances and items plugged into the electrical outlets of the motorhome. The number of electrical appliances that can be operated at any given time depends upon how

much power is available from the generator. If the generator is "overloaded" or a short circuit causes "over current," either the generator will shut down or the circuit breaker will trip. If power consumption, in total, exceeds the generator power output, compensation for temperature and elevation may be necessary. Operate appliances in sequence, rather than all at the same time.

NOTE:

The generator may shut down when loaded nearly to full power and an air conditioner (or other large motor load) cycles on. For a brief moment during start up an electric motor can draw up to three times the rated power. For this reason it may be necessary to operate some appliances in sequence when air conditioners or other large motor loads are on.

Compensation for temperature and elevation may also be necessary. The generator's maximum output is rated at 500 feet above sea level. Beyond this point, the generator will lose approximately 3.5% of its rated power for every 1000 feet gained in elevation. High and low temperatures can also affect generator output. Power decreases 1% for every 10° F above 85° F. Counteract these effects by operating appliances in sequence rather than at the same time.

INFORMATION:

The generator may shut down for reasons other than an overload. If a blink code appears on the control switch, refer to the manufacturer's manual to obtain an explanation for the code.

Generator Fuel

There is always a possibility fuel may be contaminated. Diesel fuel may contain water or a microbe growth (black slime). Any contamination of fuel will greatly reduce the total output of the generator, and may cause erratic AC output.

NOTE:

The motorhome manufacturer does not cover damage to the generator caused by fuel contamination, or to appliances due to erratic AC voltage.

Average Fuel Consumption	Diesel 10,000 Watts (gal./hrs.)
No Load	.1
Half Load	.6
Full Load	1.1

Resetting the Circuit Breaker

If a circuit breaker trips in the main AC breaker panel, or on the generator control panel, there may be a short circuit or too much load.

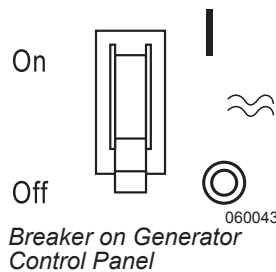

NOTE:

The generator will continue to run after a circuit breaker trips.

If a circuit breaker trips, disconnect or turn off as many loads as possible. To reset the circuit breaker, switch the circuit breaker to **OFF**, then switch back to **ON** to reconnect the circuit.

If the circuit breaker immediately trips, the electrical distribution system has a short or the circuit breaker is faulty. Call a qualified electrician. If the circuit breaker does not trip, reconnect a combination of loads that will not overload the generator or cause the circuit breaker to trip again. Remember to compensate for elevation and temperature changes when reconnecting loads.

NOTE:

An appliance or load may have a short if it causes a circuit breaker to trip after reconnection. DO NOT continue to reset breaker. Have the problem corrected before resuming operation.

Generator Exercise

If use of the generator is infrequent, “exercise” the generator once a month by operating it at approximately half the maximum rated output for two hours. This “exercise” will help promote better starting, more reliable operation and longer engine life. This procedure drives off moisture, lubricates the internal engine parts, replaces the old stale fuel with a fresh supply, and also promotes removing oxides from the electrical switches and contacts.

NOTE:

Avoid short run periods of the generator. Run the generator set under a load for a minimum of one-half hour.

INVERTER

The inverter changes DC battery power to AC electrical power, and it also charges the batteries when hooked to shore power or operating from the generator. Use the inverter to supply AC power when shore power is not available and the generator is not going to be used as a secondary AC power source. The inverter supplies AC power to most outlets and appliances. Remember that using the inverter quickly consumes house battery power. Turn off the inverter when not in use to conserve house battery power. The remote panel is used to change the variable settings.

Providing AC Power with Inverter

To turn the inverter on:

Press the **INVERTER ON/OFF** switch at the remote panel or in the bedroom. If the inverter doesn’t sense AC power from the generator or shore power, it will provide AC power from the motorhome batteries to most outlets and appliances. If the generator is started or the motorhome is connected to shore power, the inverter will automatically begin charging.

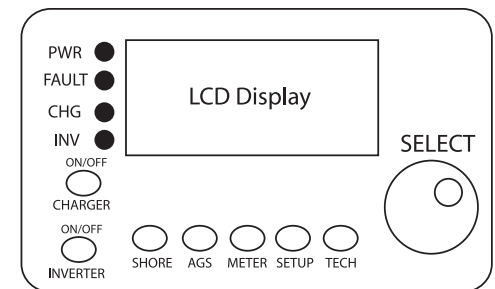

Remote Panel

Battery Charging with the Inverter

The inverter will automatically begin charging when AC power is supplied from shore service or the generator. The inverter uses a three-stage charge cycle to charge the batteries. If desired, the charger may be turned off.

To turn the charger on and off:

- ◆ Press the switch marked **CHARGER ON/OFF** on the remote panel.

Inverter three-stage charging cycle:

- ◆ **Bulk Charge Cycle:** Brings the DC voltage up high, initially between 14.2 - 14.6 Volts DC. The length of time the inverter is in Bulk Charge depends the state of charge of the batteries.
- ◆ **Absorb Cycle:** Absorb Cycle battery voltage is the same as the Bulk Charge Cycle, between 14.2 - 14.6 Volts DC. Length of the Absorb Cycle is a timed event determined by the inverter.

- ◆ **Float Charge Cycle:** Charge voltage is generally around 13.3 - 13.7 Volts DC. Approximately 80% of the charging cycle has been completed by this time.

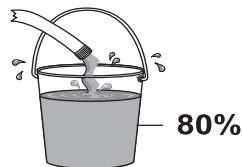

Bulk Charge

Water (charger) on full until bucket (battery) is 80% full.

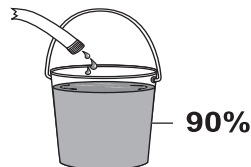

Absorb Charge

Water (charger) slows until bucket (battery) is 90% full.

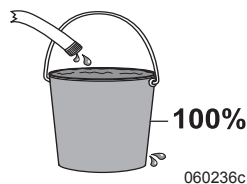

060236c

Hose = Inverter in Charge Mode
Bucket = Battery

Float Charge

Water (charger) slowly trickles into bucket (battery) until 100% full. Water (charger) will adjust flow to maintain level.

NOTE:

Refer to the OEM manual located in the Owner's Information File Box for detailed instructions.

Auto Generator Start

The **Auto Gen Start (AGS)** allows the inverter remote control to start the generator when battery voltage or interior motorhome temperature reaches a preset point.

NOTE:

Generator run time, battery voltage and interior temperature settings for the **AGS function** are selected with the **AGS controller** located in a cargo bay next to the inverter. Refer to the **OEM manual** located in the **Owner's Information File Box** for detailed instructions.

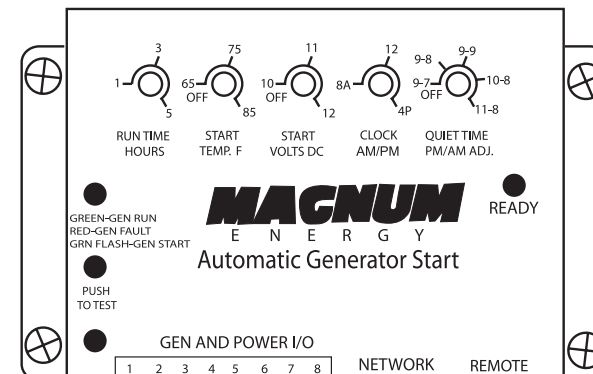

AGS Controller: Located next to inverter in large pass-through bay. 060299

To Enable AGS:

- ◆ Press the AGS button on the inverter remote panel. Use the select knob to scroll through the AGS menu options until "AutoGenSt Enabl" appears. Press the select knob to activate the AGS.

To Disable AGS:

- ◆ Press the AGS button on the inverter remote panel. Use the select knob to scroll through the AGS menu options until "AutoGenSt OFF" appears. Press the select knob to deactivate the AGS.

Factory Default Settings

NOTE:

The Inverter/Charger will charge the batteries with AC power applied regardless of remote status.

Function	Default
Search	5 Watts
Low Battery Cutoff	11 Volts DC
Battery Bank	400 AH
Battery Type	Liquid Lead Acid
Charge Rate	80 %
Contrast	75 %

Battery Temperature Sensor

A **Battery Temperature Sensor (BTS)** is affixed to one of the house battery terminals to measure battery temperature and send that information to the inverter. When battery temperature rises, the inverter will decrease charge voltage to prevent boiling the batteries. When battery temperature cools, the inverter will raise charge voltage. Voltage compensation with temperature variation is necessary to keep charge voltage at optimum values. If the BTS cord is unplugged from the inverter, the inverter will use a temperature default setting of 77° F/25° C as a reference point.

DISTRIBUTION PANELS - HOUSE 120/240 VOLT AC

The AC distribution panels are located in the roadside overhead cockpit cabinet. The main 240 Volt AC panel receives power from the transfer switch, which is supplied by either shore power or the generator. The AC power is

supplied to the 50 Amp main breaker first, then the power is supplied to the individual branch circuit breakers. The panel label describes the breaker layout and the item, outlet or appliance to which they pertain.

The sub panel may also receive AC power from the inverter and supplies power to items which can be operated by the inverter. The AC power produced by the inverter supplies power to the sub panel only.

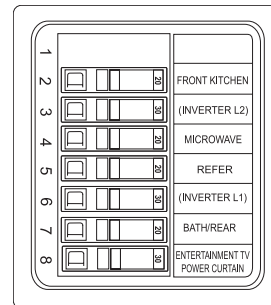

060143g

Typical Sub-panel:
Located in the roadside overhead cockpit cabinet.

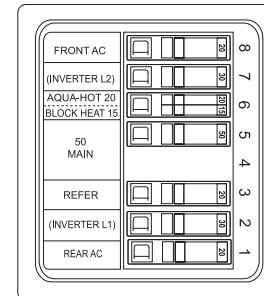

060142e

Typical Main Panel:
Located in the roadside overhead cockpit cabinet.

WARNING:

The 120/240 Volt AC panels contain high voltage which can cause serious injury or death. Before beginning any work or testing procedures involving the electric panels, or any of the branch circuits, be sure the motorhome is unplugged from shore power, the generator is not running and the inverter is in the off position. Certain testing procedures may require the AC power to be on. Only qualified personnel with electrical backgrounds should attempt any testing procedures.

Circuit Breaker

The internal configuration of the circuit breaker is designed to trip when excess current causes the breaker to heat up. The trip action of the circuit breaker can occur within milliseconds due to the speed at which electricity can travel. Breakers are designed to operate at a continuous load of 80% of the breaker's rated capacity. **For example:** A breaker with a 20 Amp rating will operate a continuous 16 Amp load. This design leaves a small amount of working capacity within the breaker. When an inductive load is applied, such as when an electric motor turns on, the motor starts to spin and current consumption may momentarily exceed the rated capacity of the breaker. As the electric motor comes up to operating speed, the electric motor's current consumption will decrease. The AC current load then falls back into the breaker's rated 80% set point. This electric principle should be kept in mind when using anything other than 50 Amp shore service and using appliances with electric motors, such as air conditioners. When using outlets, care should be considered when applying loads such as electric motors, heaters, coffee makers, toasters, hair dryers or other large current consuming loads. The current rating is usually stated on most electrical items. The current rating will either be rated in amps or watts. Current ratings stated on electrical items will change slightly with voltage fluctuations. As voltage increases, current consumption decreases. As voltage decreases, current consumption increases. This may explain why in some instances items operated at borderline voltage to current tolerances may seem fine in one location but problematic in another.

NOTE:

To calculate watts to amps simply divide the watt figure by the voltage of which the item operates from. For example: The electrical item is rated at 1370 watts. Divide that by the operating voltage of 115 Volts AC which equals 11.913 Amps. Use this formula to calculate the amount of load and compare to the available power supply.

GFCI BREAKERS & OUTLETS

A Ground Fault Circuit Interrupter (GFCI) can be found in two different types of applications. One type is incorporated in a breaker used in 120 Volt AC breaker panels; the other is incorporated in an outlet.

The GFCI, whether it is a breaker or an outlet, offers two types of protection. One type of protection is from over-current or shorts to guard against hazardous ground fault currents that can result in injury or death. Ground fault currents are currents that flow from the “hot” or power terminal through a person to the ground. **For example:** touching a faulty appliance while standing on or making contact with an electrical ground such as a water fixture, bath tub or the earth.

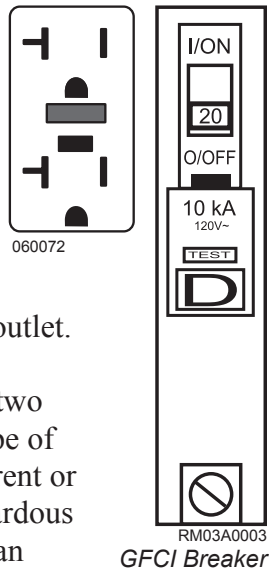

The GFCI offers protection against the type of shock that can result from faulty insulation, wet wiring from inside an appliance, or any device or equipment plugged in or wired to that circuit. The ground fault portion of the outlet or breaker uses sensitive electronics inside the outlet or breaker to detect a ground fault problem. The electronics monitor the normal current of power flowing to the hot (black) wire through the load (eg. a light bulb or appliance) and coming back on the neutral (white) wire. If a small amount of current comes back on the safety ground wire, the electronics will trip the breaker or outlet, stopping the flow of electricity. The amount of current it takes to trip the device from a ground fault varies slightly from the different outlet or breaker manufacturers (approximately 4-6 milliamps or less).

Electrical shocks resulting from ground faults can be felt, but such a shock is considerably less than one without ground fault protection. People with medical conditions that make them susceptible to shock, can still be seriously injured. A GFCI outlet or breaker will not protect against shock from a normal current flow. **For example:** a shock from touching both metal prongs of an electrical cord or appliance while plugging it in.

WARNING:

If a breaker or outlet continually trips, DO NOT continue to reset breaker or outlet until the problem has been identified and corrected.

NOTE:

The ground fault outlet or breaker should be tested once a month to ensure it is operating. Use the TEST button on the outlet or breaker. It should trip with an audible “click.” The breaker or outlet will not trip if AC power is not present at the device. If power is present and the device will not trip, replace it before using that circuit.

NOTE:

One milliamp is 1/1000 of one amp.

DISTRIBUTION PANEL - HOUSE 12 VOLT DC

The 12 Volt DC house distribution panel (located on the multiplex board in the bedroom closet) contains fuses that protect the electrical circuits. These fuses are a standard automotive type.

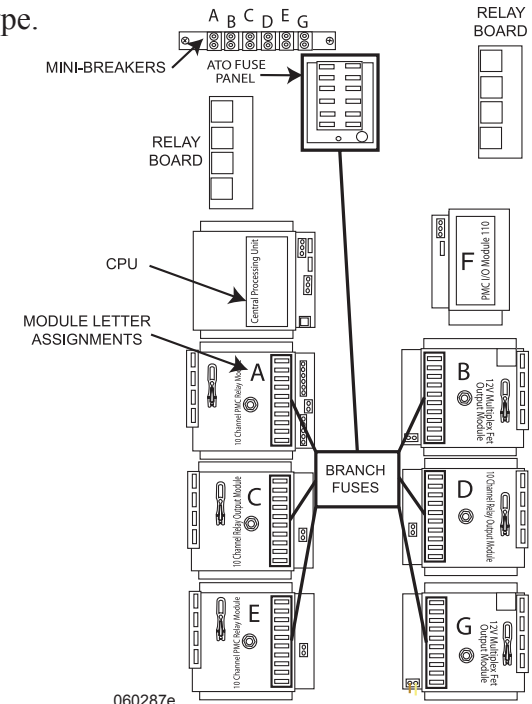

Multiplex

The Programmable Multiplex Control (PMC) is a communications and switching system. The Multiplex system allows the transmission of multiple “bits” of information down a single data transmission wire.

When a switch is pressed information is gathered through the remote modules and is directly communicated to the CPU. The CPU then interprets the inputs, determines the state of all outputs and communicates that information to operate the selected component.

Operation:

Some switches operate items directly, such as a light or the water pump. Other items are programmed to go through a series of checks before the switch will operate the item, such as the slide out.

- ◆ All dimmable lights have seven dimmer settings. Press and hold the switch to cycle through the different settings. If the light is dimmed and turned off; the system will remember the dimmed setting when turned on again. The rear closet light and ceiling fluorescent lights are not dimmable.
- ◆ The Master Off switch will turn most interior lighting off. Press and hold the switch for three seconds. Each light will have to be turned on again individually.
- ◆ The front TV lift (optional) has a short delay. Press and hold the switch until the TV is at full extension or completely stowed.

Troubleshooting:

- ◆ Ensure the Battery Cut-off switch is on.
- ◆ If a switch is pressed and the backlighting doesn't turn on, check the fuse located on the ATO fuse panel in the closet on the Multiplex board. Also check the 10 Amp fuse on the CPU.
- ◆ When the switch is pressed and the yellow communication LED does not illuminate, check the 5 Amp fuses on the CPU and the 330 module.
- ◆ If the backlighting turns on and the yellow communication LED illuminates but the item does not turn on, check the fuse for that circuit. Each module is labeled to show the circuit assignments.

FUSES

The 12 Volt DC fuses, located in this distribution panel, service the interior house lighting, ventilation fans, monitor panel and Aqua Hot. Should a fuse blow it will be evident by the broken metal strip located in the center of the fuse. Replacement fuses should be of the same amperage. If a higher rated fuse is installed it can damage the wiring. Fuse current set points follow much of the same electrical principle as the 120 Volt AC breakers. Using 12 Volt DC as the electromotive force can make it more susceptible to outside influences, such as corrosion from weathering or oxidation.

The danger from shocks with this voltage is minimized, but can still occur. A good example is when a magnetic field is generated, then collapses when the power supply is cut. The result is a discharge that can reach tens of

thousands of volts for a short time period. Care should be used when working with this voltage as current values can be quite high, as in the case of battery cables.

Shorting a battery cable to ground with a battery at a reasonable state of charge can result in a fire or serious personal injury from a burn.

AMPERAGE	COLOR
1	BLACK
2	GRAY
3	VIOLET
4	PINK
5	GOLD
7.5	BROWN
10	RED
15	BLUE
20	YELLOW
25	CLEAR
30	GREEN

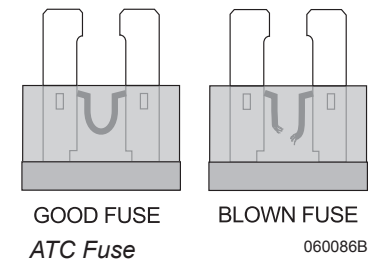

BATTERIES - HOUSE

House batteries are designed for use with 12 Volt DC operated lights, appliances and inverters.

NOTE:

Tap water contains minerals which can alter battery chemistry and ruin the battery. Use only distilled water when refilling the LLA battery.

Slide Tray Operation:

The slide-out battery tray is secured in place by a locking mechanism at the front of the tray. To slide the tray out, lift up on the handle and pull until the tray stops. To secure the battery tray, push it back in until the tray latches.

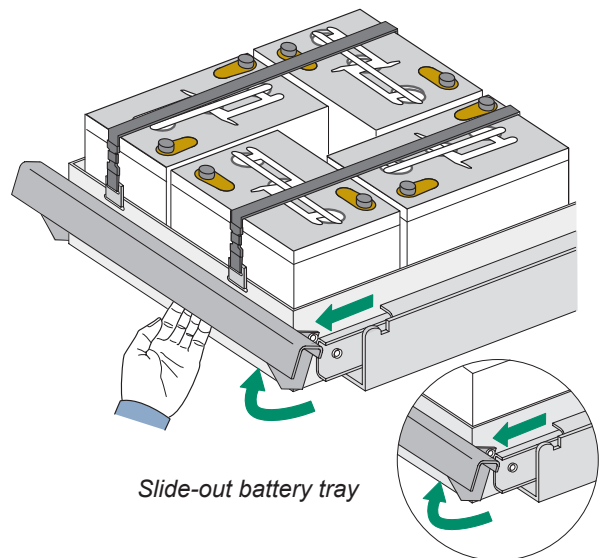

Slide Tray Maintenance:

The battery tray slide will occasionally require lubrication. When performing maintenance to the batteries, remove old lubricant and dirt from the battery tray slide with solvent, brake cleaner or equivalent. **DO NOT** allow any cleaning solution or battery acid by-products to splatter onto and damage the painted surfaces. Lubricate all moving parts of the battery tray slide with white lithium grease or Kwikie brand spray lubricant.

NOTE:

Driving without the tray secured can result in damage.

CAUTION:

Many types of petroleum based products or battery by-products can damage the paint finish. DO NOT allow these types of chemicals to get on the paint finish. If the chemicals splatter on to the painted surfaces, immediately rinse the surface using plenty of water and a mild automotive detergent.

Battery Maintenance

Liquid Lead Acid (LLA) battery cells should be checked at least once a month. The level should be above the top of the plates, but not overfull. The electrolyte level should be approximately 3/8" below the well to allow room for expansion while the battery is being charged. Over-filling the battery will allow the electrolyte solution to boil or gas out of the battery cap. Remember to use only distilled water to refill the battery. A battery with a low electrolyte level will rapidly boil out the water once the plates have been exposed to air.

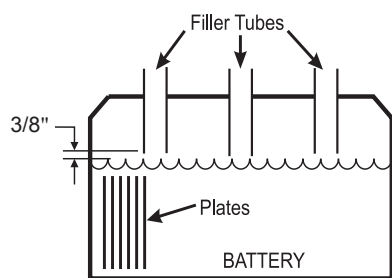

Battery State of Charge	Spec. Gravity	Voltage
100%	1.265	12.7
75%	1.225	12.4
50%	1.190	12.2
25%	1.155	12.0
Discharged	1.120	11.9 or Less

NOTE: The distilled water level in battery should be 3/8" below the filler tube. 020034c

Periodically check the batteries for corrosion and cracks. Replace vent plugs that are cracked or missing. Keep the top of the batteries clean. The accumulation of electrolyte and dirt may permit small amounts of current to flow between the terminals, which can drain the battery.

Check the battery connections for tightness and corrosion. If corrosion is found, disconnect the cables (mark cable locations) and carefully clean them with a mild solution of baking soda and water, or an aerosol product specifically designed for battery maintenance. **DO NOT** allow cleaning solution to seep into the battery and damage the electrolyte balance. Use water to rinse the top of the battery and surrounding area when done. Carefully hook the cables back to the battery. The battery cable to battery terminal connections should be metal to metal. Coat the terminals with petroleum jelly or an anti-corrosion grease.

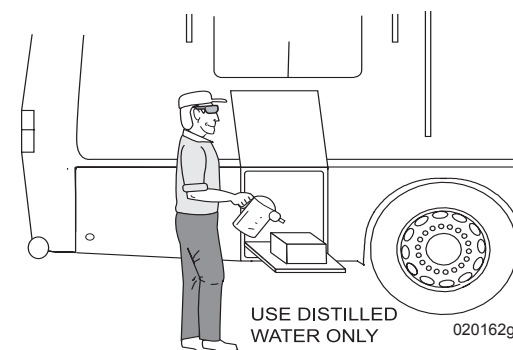

WARNING:

Liquid lead acid batteries produce hydrogen gas while being charged. This is highly explosive. DO NOT smoke around batteries and keep all sources of ignition or flames away from batteries. The hydrogen gas may explode resulting in fire, personal injury, property damage or death.

Testing the Battery

A battery can be tested and/or monitored several ways. The Aladdin™ system will show the voltage and amperage of the house batteries on the Coach Electric Status screen.

Checking the Electrolyte Solution (LLA Only)

The most efficient way of testing the batteries is to check the electrolyte solution. The only way to test a battery's electrolyte solution is with a hydrometer.

Many styles are available, from types with cylinder graduation (shown here) to types with floating balls. Hydrometers can be purchased from most auto parts stores. The hydrometer tests the battery's electrolyte solution which is measured in specific gravity. Distilled water has a specific assigned gravity of 1,000. The hydrometer is calibrated to this mark. Pure sulfuric acid has a specific gravity reading of 1,840. The acid is 1.84 times heavier than water. The electrolyte solution is about 64% water to 36% acid (fully charged battery). Hydrometers with cylinder graduation are graphed and the exact state of specific gravity can be determined.

Temperature and recent battery activity (charging or discharging) affect the hydrometer readings. It is best to check the battery when

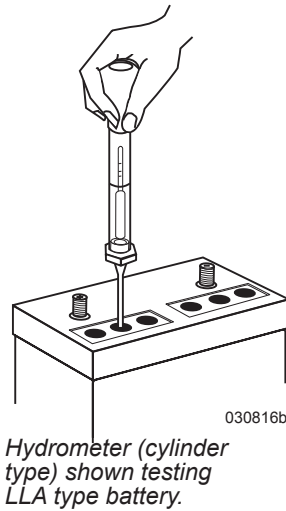

it has been at rest for at least three hours, although readings taken at other times will give a ballpark figure. When using the hydrometer, draw the electrolyte solution up into the tube. Allow the hydrometer to attain the same temperature as the electrolyte solution. Note the reading for that cell. Complete the same test for the rest of the cells on that battery bank.

The hydrometer is calibrated at 80° F. Temperature affects the hydrometer readings. The higher the electrolyte temperature, the higher the specific gravity reading. The lower the temperature, the lower the specific gravity reading. Add or subtract four points for each 10° variance from the 80° F chart. Readings between cells should not vary more than 50 points.

If one cell in a particular battery bank being tested is at a 50% state of charge while the others are indicating a full charge, charge only that battery to see if the low cell will come up. At the same time, do not over charge the healthy cells.

If the low cell does not come up after charging, this battery can damage the rest of the battery bank and should be replaced. An accurate digital Volt meter + - .5% will also give an indicator of the battery's state of charge.

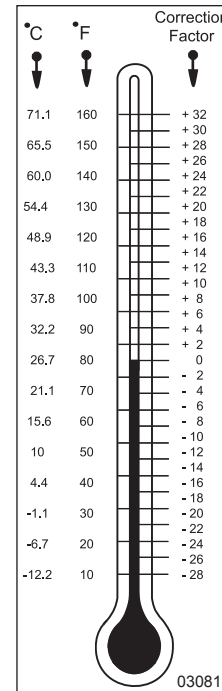

Placing a load on the Battery:

Another test that can be performed is to place a specific load on the battery for a predetermined length of time equal to that particular battery's rating. This machine is usually an adjustable carbon pile that can vary the load being applied to the batteries while monitoring voltage to see if they will perform to their specific rated capacities.

NOTE:

See the chart for temperature compensation. Liquid levels should be even between the cells of the battery being tested as it will affect the accuracy of the test.

WARNING:

Sulfuric acid in the batteries can cause severe injury or death. Sulfuric acid can cause permanent damage to eyes, burn skin and eat holes in clothing. Always wear splash-proof safety goggles when working around the battery. If the battery electrolyte is splashed in the eyes, or on skin, immediately flush the affected area for 15 minutes with large quantities of clean water. In case of eye contact, seek immediate medical aid. Never add acid to a battery once the battery has been placed in service. Doing so may result in hazardous splattering of electrolyte.

Battery Charge Time & Consumption Rate

Calculating Run Times:

Calculating run time figures when operating 120 Volt AC electrical items with an inverter can be exponential due to battery characteristics. Flow characteristics of electrons vary with different battery types and chemical compositions. Deep cycle batteries are generally designed to slowly release a majority of their charge capacity. Deep cycle batteries are rated in amp hours (Ahrs) with the discharge occurring over an extended period of time before the battery is charged. Engine starting batteries are designed to quickly release large amounts of current for short durations, without depleting battery reserves. Commercial type batteries bridge the gap of deep cycle and engine batteries. Commercial batteries release medium amounts of current over a longer period of time but they are not designed to cycle their charge capacity.

The working range of a deep cycle battery is between 50 and 100% state of charge (SOC). Deep cycle batteries should not be cycled below 50% state of charge. Discharging a deep cycle battery below 50% state of charge shortens the life of the battery. Deep cycle batteries use an amp hour rating which is usually calculated over a 20 hour discharge interval. **For example:** A deep cycle battery with a rated capacity of 100 Ahrs. is designed to release current at the rate of 5 Amps per hour. Multiply a 5 Amp load over a 20 hour discharge period equals the rated 100 Ahr. capacity. These discharge figures are calculated with the battery starting at 100% state of charge with the battery at 80° F when the discharge cycle begins. However, increasing

the discharge load applied to the battery from 5 Amps to 10 Amps on a 100 Ahr battery does not yield ten hours of discharge time. This is due to the internal reactions which occur when a battery is discharging. Actual discharge time for a 10 Amp load may be closer to eight hours of discharge time. Increasing the load applied to the battery to 20 Amps will not yield five hours discharge time but may be less than three hours. It might be understood as a point of diminishing return.

Calculating applied loads to an inverter to approximate run time from the battery amp hours available is not an equal trade up when voltage is inverted and amperage is calculated. When the inverter is used to operate an AC load it uses approximately ten times the DC current needed from the battery when inverting 12 Volts DC to operate the 120 Volt AC item. There is also a small efficiency loss of about 10% when inverting. **For example:** When using the inverter to operate an AC electrical item, which has a current draw rating of 2 Amps, the inverter will use over 20 Amps DC power from the batteries.

Determining Current Consumption:

First determine the amount of current used by an AC item. **For example:** The television is rated at 200 watts at 120 Volts AC. Calculate watts to amps. Divide 200 watts by the operating voltage of 120, this equals 1.6 Amps. Multiply 1.6 Amps AC current by a factor of ten the inverter will use, this equals 16 Amps DC battery current. Add the revised 10% efficiency loss figure, this calculates to a total of 17.6 Amps DC. If the battery bank capacity is rated at 500 Ahrs., actual elapsed time to the suggested 50% state of charge would net viewing time for the television at approximately 13 hours in ideal conditions.

The run time figure will vary greatly with the actual state of charge of the battery bank when the discharge process begins. Ambient temperature, combined with other working loads, such as lights and parasitic loads applied to batteries, affect run times. Calculating the exact run time is not precise due to all the variables and equations involved; however, an approximate time figure can be obtained. Proper battery maintenance and charge cycles affect battery performance. Observe the battery condition with hydrometer and voltage readings. Use only distilled water when filling batteries. To achieve the highest quality of battery performance and longevity maintain the batteries in their proper operating range.

SOLAR PANEL (OPTIONAL)

The solar power system consists of one solar panel with mounts, a Combiner box and a charge controller that can handle up to five 100 watt solar panels.

Solar Panel:

The solar panel is a laser-grooved, buried-grid panel that is capable of delivering about five amps of charge per hour, per panel, in full sunlight. One 100 watt solar panel delivers enough power to offset the normal day-to-day drain on batteries caused by various parasitic electrical loads, such as transmission memories, alarm systems, natural self-discharge of batteries and other like items. Adding a second, third or more solar panels (up to five, depending upon needs and electrical consumption) can replace what is drawn out of the batteries from the operation of lights, water pumps, inverters, etc., while dry camping.

Charge Controller

The Charge Controller is set to accommodate either **Liquid Lead-Acid (LLA)** or **Absorb Glass Mat (AGM)** batteries. The Charge Controller is located in the roof of the large pass-through bay. The controller is used as a heat sink for the electronics attached to it. It is normal for the controller to become warm to the touch, especially when processing higher amperage. The charge controller will automatically enter Thermal Shutdown if it gets too warm. Status of the charge controller is viewed through the Aladdin System electrical status display.

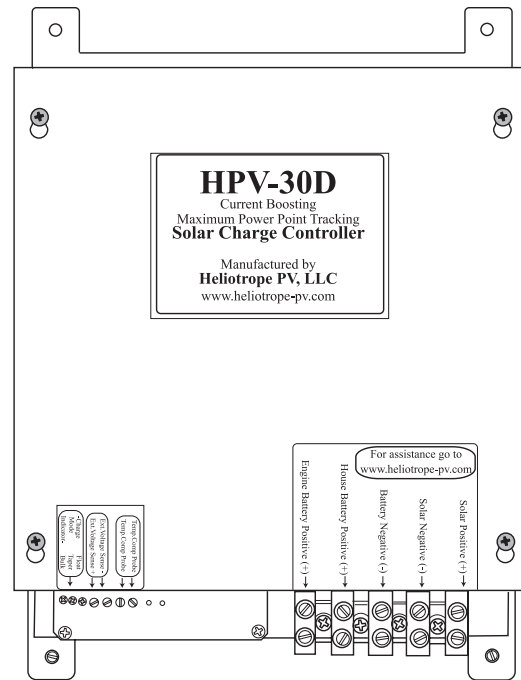

Charge Controller: Located on roof of large pass through bay. 080418e

NOTE:

The charge controller battery settings are preset at the factory.

The HPV-30D Charge Controller includes the following:

- ◆ **Dual Battery Bank Charging** - The controller automatically sends charge to both the House and Engine batteries at the same time.
- ◆ **Pulse Width Modulation** - Delivers all the available charging amperage until the batteries reach their set point voltage (Bulk) and then it begins to taper off amperage (Absorption) until it is reduced to all that is needed to simply hold the batteries at their set point voltage (Float).

- ◆ **Temperature Compensation** - Protects the batteries from excess water loss and/or plate sulfating by automatically compensating for temperature changes, and adjusting the charging voltage accordingly.

CAUTION:

The Charge Controller may be warm to the touch. This is a normal function of the Charge Controller.

Solar Panel Care

A critical part of maintaining the solar electric battery charging system is to keep the panel clean. The amount of power that a panel will produce is directly related to the intensity of sunlight. Dirt will allow less light to reach the panel, resulting in a reduction of power produced. A single layer of dust or road grime can reduce the power output by 15 to 25%. Debris covering two or three of the 36 individual cells can reduce output power by 50 to 75%.

Use of the basic maintenance tips, routine inspection and regular cleaning will assure maximum charging from the solar panel system. To clean the panel, use a non-abrasive cleaner and paper towels. The surrounding environment, and the amount of road dust encountered, will determine how frequently the panel should be cleaned.

NOTE:

Solar panels should be cleaned monthly, or more frequently depending upon weather conditions.

Tips to Follow:

1. The panel should be cleaned if a film or a layer of dust is on the windshield.
2. On a bright sunny day, charging amps should be 3.5 to 5 Amps per panel.
3. High winds can blow dust and debris around causing dirt build up. Frequently inspect the panels and clean as necessary.

CAUTION:

To avoid arcing at battery connections when replacing batteries or performing battery cable maintenance, be sure to remove the fuse for the solar panel charge controller, or cover the solar panel to stop the production of electricity at the source.

LIGHTS

Interior Halogen

The bulbs inside the halogen lighting are replaceable.

To Replace a Bulb:

1. Rotate the outer trim ring counterclockwise and remove.
2. Carefully grasp bulb and pull from socket.
3. Use a clean cloth or piece of tissue to grasp new bulb. **DO NOT** touch bulb directly as this can cause a “hot spot” and result in immediate bulb failure.
4. Align contacts of bulb with terminals in fixture base. Insert bulb until contacts are firmly seated.

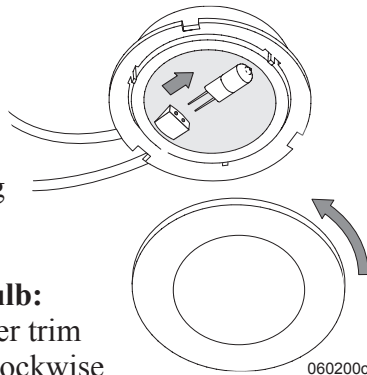

5. Align tabs in trim ring with slots in fixture base. Rotate lens clockwise until trim ring locks into place.

CAUTION:

DO NOT touch halogen lighting while on. They can cause a burn. DO NOT touch replacement bulbs. Oil in the hands can cause a “hot-spot” to occur. If the bulb is touched, allow it to cool and clean the bulb with alcohol.

Map Lights**Operation:**

Turn the light on and off by aligning the pointer on the back of the light with the **ON** and **OFF** indicator on the front portion of the light.

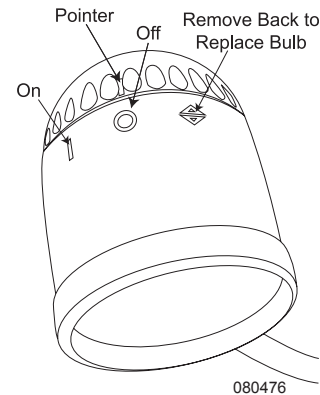
**To Replace a Bulb:**

1. Align the pointer on the back of the light to the position to remove the cover.
2. Remove cover and lift bulb from holder.
3. Replace with a 12 Volt DC 4 Watt type 1816 bulb and install cover by realigning the pointer to the same location. Turn cover to **OFF** or **ON** position.

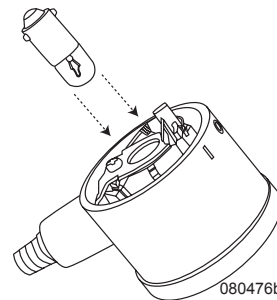
**If Map Lights Fail to Operate:**

- ◆ Ensure Coach Power switch is turned **ON**.
- ◆ Check fuses in front electrical bay on the roadside.

BULB USAGE – INTERIOR

INTERIOR BULB CHART	
LOCATION	BULB NUMBER
FLUORESCENT CEILING LIGHTS	F15T8 - CW
DINETTE	12V DC C912
ROUND 3" HALOGEN CEILING LIGHT	12V DC 10W Type T-3
ROPE LIGHT	LITCO 31-120-40
ENTRY HANDLE LIGHT TUBE	MP# 16615157
MAP LIGHT	1816 12V DC 4W
STEPWELL LIGHTS	90416
CLOSET LAMP	12V DC 10W Type T-3
MASTER GEM	1003 12V DC 15CP

THE EXECUTIVE 07

ELECTRICAL SYSTEMS - CHASSIS — SECTION 9

CHASSIS ELECTRICAL - INTRODUCTION	196
BATTERY DISCONNECT - CHASSIS	196
BATTERY - CHASSIS	196
FUSES & CIRCUITS	197
Rear Start Switches	197
Isolator Relay	198
Relays	198
ALTERNATOR.....	199
Alternator Testing Procedure.....	200
STEERING COLUMN & SMART WHEEL	200
Smart Wheel Operation	200
Wiper Function	201
Tilt & Telescope	202
CONSOLE	202
Transmission Shift Selector	202
DASH	204
Instrument Panel	204
Indicator Lights	206
Switches	207
DASH AIR CONDITIONER & HEATER CONTROLS	209
Operating Tips & Hints	210
System Components	211
Troubleshooting	212
SYSTEM CONTROL CENTER.....	213
DIAGNOSTIC PLUG LOCATION.....	213
ALADDIN™ ENGINE DISPLAY.....	213
ENGINE “NO START” - FLOW CHART	214

CHASSIS ELECTRICAL - INTRODUCTION

This section contains guidelines, procedures and information that will assist in understanding the chassis electrical system and the operation of various components. Refer to the OEM manuals included in the Owner's Information File box for their respective, in-depth, individual component operating instructions.

BATTERY DISCONNECT - CHASSIS

The main battery disconnect switch, located in the curbside battery compartment, controls the DC power to the front electrical bay and to most components in the rear run box. Most chassis and engine functions are interrupted when the battery disconnect is turned off. Some electronic components of the engine and transmission require a constant power source and will continue to draw power when the disconnect is engaged.

Turn the main battery disconnect switch off when the motorhome is going to be stored or when performing electrical maintenance. If possible, leave the motorhome plugged into an AC source with the battery disconnect switch on to help prevent the possibility of dead batteries.

If an AC source is not available, and the motorhome is going to be stored more than 48 hours, it is recommended to turn the battery disconnect switch off.

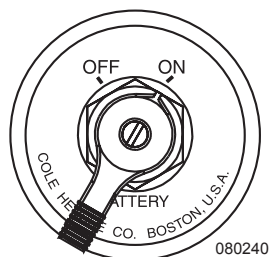

Battery Disconnect:
Located in the curbside battery compartment.

WARNING:

When welding is involved for motorhome repair or modification, only qualified, experienced technicians should weld on the chassis. Improper welding procedures and materials may weaken the assembly or result in damage that is not obvious and may not cause an immediate problem or failure. Unauthorized modifications or repairs to the chassis could result in a forfeiture of warranty coverage.

DANGER:

Due to the sensitive nature of the electronics on the chassis, the following precautions are required to protect electrical components in the motorhome chassis:

1. Disconnect the (+) positive and (-) negative battery connection.
2. Cover electronic control components and wiring to protect from hot sparks.
3. Disconnect the terminal plugs from the engine Electronic Control Unit, located on the passenger side of the engine block.
4. Disconnect all the plugs from the transmission Electronic Control Unit, located in the storage bay between the frame rails.
5. Disconnect the wiring from the alternator.
6. **DO NOT** connect welding cables to electronic control components.
7. Attach the welding ground cable no more than two feet from the part to be welded.

BATTERY - CHASSIS

The chassis battery is designed to produce high amperage necessary to start the engine. Maintain the chassis battery through regular electrolyte level inspections and hydrometer readings. High electrolyte consumption, or inconsistent hydrometer cell readings, may indicate a charging system problem. Perform a charging system and current draw check if the battery is exhibiting abnormal hydrometer readings.

NOTE:

Replacement batteries should have the same cold cranking amp (CCA) rating.

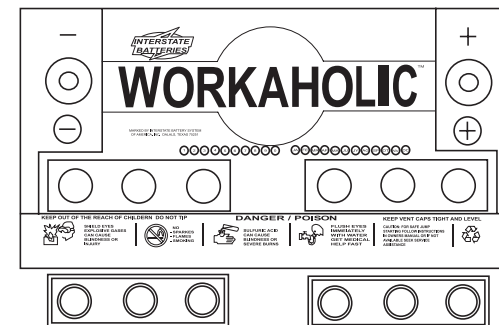
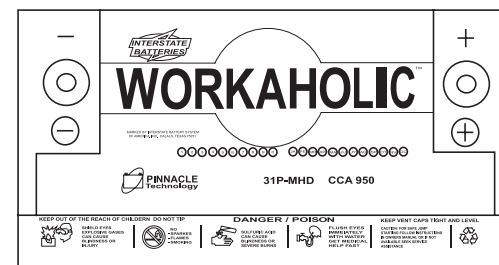

Battery with cover removed. Cut plastic to remove cover.

080460

FUSES & CIRCUITS

The motorhome relies on two electrical panels to control chassis system functions and some house operated items. One electrical panel, located roadside ahead of the front wheel, contains fuses, self-resetting circuit breakers and micro-relays. The other electrical panel, located in the engine compartment, contains high-amperage circuit breakers, a high-amperage solenoid and the rear start box. The circuit cards in both electrical panels use LEDs to indicate power.

- ◆ **RED** indicates Fuse.
- ◆ **GREEN** indicates Relay.
- ◆ **YELLOW** indicates Signal.

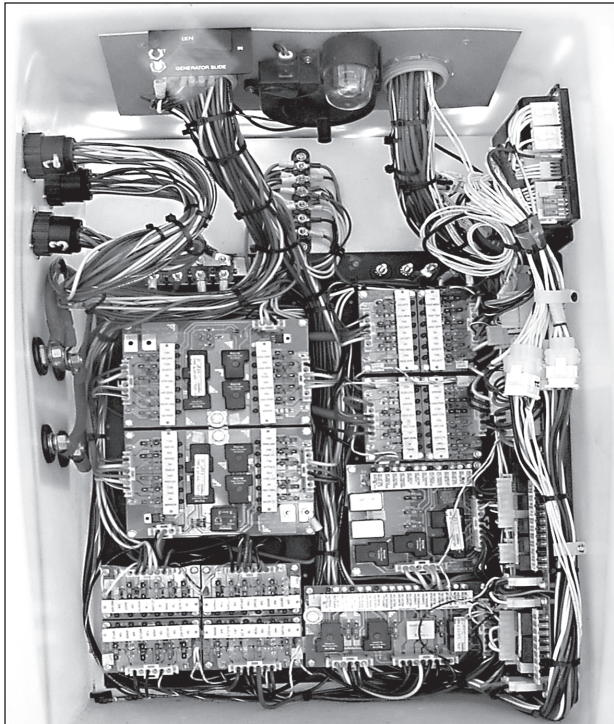

Front Electrical Bay: Located in roadside front bay.

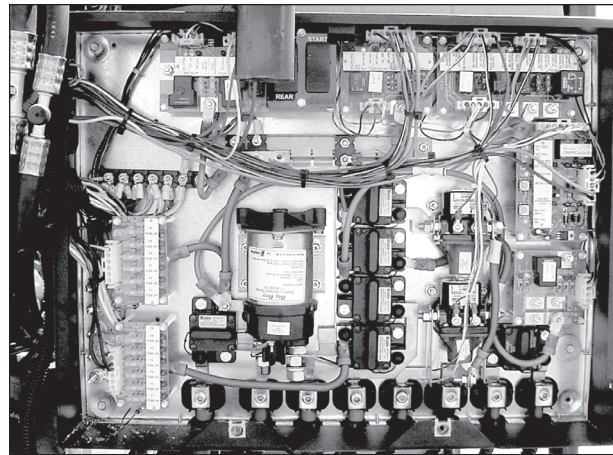

Rear Run Box: Located in engine compartment.

The fuses are standard ATC blade type. When a fuse “BLOWS,” the wire in middle of the plastic case will be broken. A bad or blown fuse must be replaced with a fuse of the same rating and type. Using a fuse of a different type or rating will defeat the circuit protection provided by the fuse, which could result in damage to the motorhome electrical system.

A fuse that has been replaced, and continues to “BLOW,” may indicate a fault exists or an electronic component has failed. It is recommended that the motorhome be taken to a qualified RV technician before any future use to diagnose and repair the potential problem. Circuits are identified with a label adjacent to the fuse.

Rear Start Switches

The rear start switches are for safety and convenience.

The FRONT/REAR switch has three positions:

1. **FRONT** - In this position the motorhome will only start with the ignition key.
2. **OFF** - In this position the starter will not engage with either ignition key or rear start switch. It will also turn the engine off if it is already running.
3. **REAR** - In this position the motorhome can only be started with the rear start switch. (Note that the ignition switch must also be in the **ON** position.)

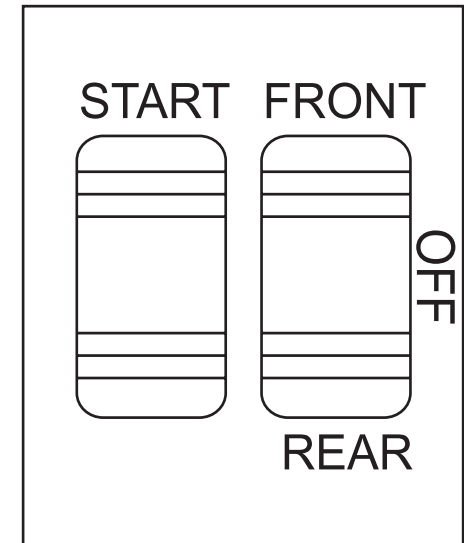

090373h

Rear Start Switches:
Located in Rear Run Box in engine compartment.

The **START** switch engages the starter when the **FRONT/REAR** switch is set to **REAR** and the ignition switch is **ON**.

NOTE:

If the motorhome will not start from the front, check the rear start box to see if the switch was bumped or accidentally set to OFF or REAR. If the motorhome still does not start, try to start it from the rear start box.

CAUTION:

When checking or servicing the engine compartment, the Rear Start switch should be placed in REAR or OFF position to prevent accidental starting of the engine from the cockpit area.

To Start From the Rear:

When starting the motorhome from the rear, confirm all tools and parts are clear of the engine and underneath the motorhome.

- ◆ Turn ignition key to the **ON** position.
- ◆ Move rocker switch on the rear start box down to **REAR**.
- ◆ Ensure everything is clear of rotating parts.
- ◆ Hold the momentary switch to **START**. After the engine starts, release the switch.
- ◆ Move switch to the center **OFF** position, to turn the engine off.
- ◆ Check the rocker switch to confirm it is in the position desired.
- ◆ For normal operation, place the switch to **FRONT**.

Isolator Relay

The Isolator Relay provides a simple means of isolating the two battery systems, house and chassis, and connecting the batteries together when the engine is running.

A momentary dash-mounted switch is added to provide a “boost” for the engine batteries from the domestic batteries.

When using the battery boost switch, the relay may have to deliver the full starting current to the engine batteries. The relay contacts must close and provide low resistance without the harmful effects of arcing. To be sure relays can perform under harsh conditions, the contacts are protected with a unique antioxidant coating. The relay is of heavy construction and can easily deliver the needed current. In a battery charging situation, both batteries will charge at equal voltage.

Relays

The motorhome uses various relays to operate electrical equipment such as lights and motors. If a relay needs to be replaced, carefully record the location of each wire and all markings or labels.

Relays can look the same in appearance, but differ in function. Note that on the side of

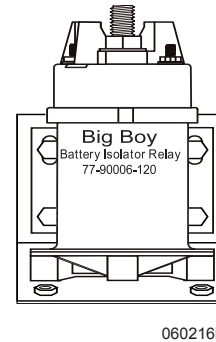

Isolator Relay:
Located in Rear Run Box
in Engine Compartment.

the relay is a schematic drawing identifying if the relay is 87 or 87a relay. These current ratings differ, and if mixed, will create problems. Ensure the replacement relay is of the current rating to assure proper operation.

Another indicator to the type of relay is the post or legs. Turn the relay over and look at the post.

Note the differences between the numbered posts:

1. The 30 post is the incoming fuse and/or breaker power.

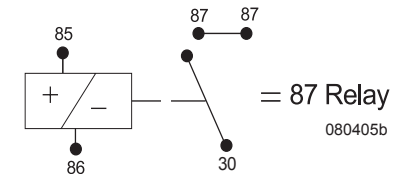

- Some relay applications supply power to the 30 post.

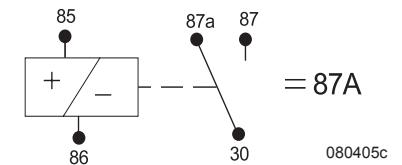

- Some use it for ground. The 30 post can be used many different ways.
2. The 85 post is one side of the coil, tripped different ways.
3. The 86 post is the opposite side of the coil, tripped different ways.
4. The 87 posts are not common to the 30 post until the relay is tripped. When the relay trips, both 87 posts are common to the 30 post.
5. Using an 87a relay, the 30 post and the 87a post are common. When the coil is tripped, the 87a post becomes inactive and the 30 post becomes common to the 87 post located on the outside of the relay.

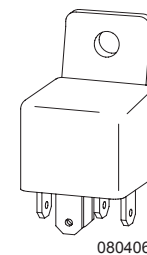

A Single Pole Single Throw relay (SPST) is an electro-magnetic switch consisting of a coil (terminals 85 & 86), one common terminal (30), one normally closed terminal (87a), and one normally open terminal (87).

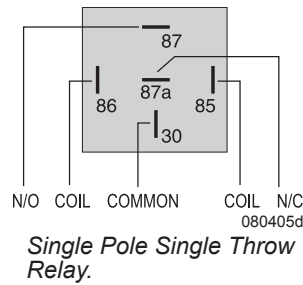

When the coil of the relay is at rest (not energized) the common terminal (30) and the normally closed terminal (87a) have continuity. When the coil is energized, the common terminal (30) and the normally open terminal (87) have continuity.

NOTE:

When there is power applied to the coil, the coil sets up a magnetic field in the windings. When the power is removed, the field collapses. A momentary high voltage discharge will occur. This is how an ignition coil works.

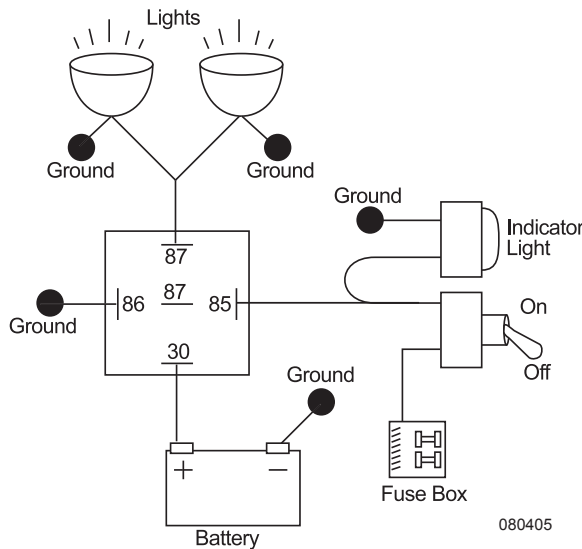

ALTERNATOR

The alternator is designed for output through the engine operating range. When traveling, keep an eye on the voltmeter in the dash area. Normal readings should be between 13 to 14.5 Volts DC. Voltage indications higher or lower indicate a potential problem with the charging system. If the alternator output drops below an acceptable level, a charge indication warning lamp will illuminate.

The alternator replaces amp hours the chassis battery used to start the engine. The amount of charge the alternator sends to the chassis battery is dependent on the amount of time the engine is operated. Repeatedly starting the engine for short periods may not be enough operating time to adequately replace the amp hours the chassis battery uses to start the engine.

The function of the alternator is an electrical system voltage maintainer, not a battery charger. When the engine is operating, the alternator maintains electrical system voltage relative to a load, such as headlights and windshield wipers. When a heavy load is placed on the alternator, such as trying to charge dead house batteries, the operating temperature of the alternator will increase. Excess operating temperature of the alternator for extended periods of operation can lead to premature failure of the alternator.

NOTE:

The alternator is not designed to charge the house batteries from a complete discharge to a full state of charge. The alternator will maintain the battery charge during travel, supplying the DC current necessary to operate running lights or other DC loads.

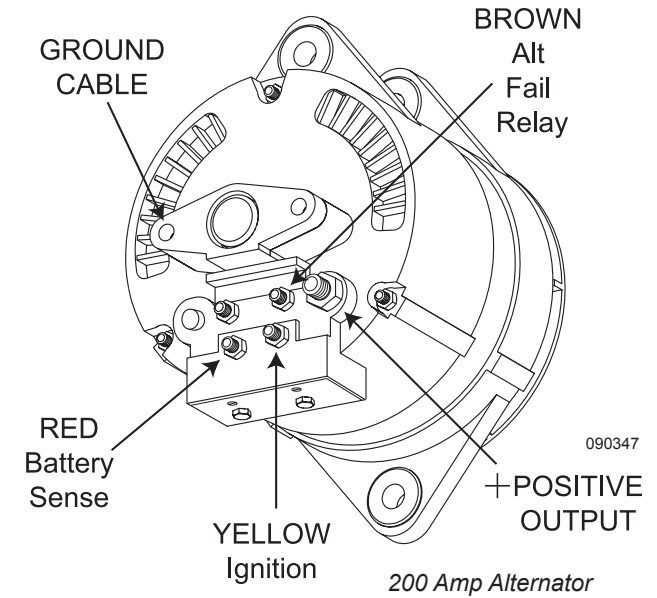

If the house batteries are in a low state of charge, it is recommended to charge the house batteries with the inverter or an auxiliary battery charger before driving the motorhome.

CAUTION:

Long-term use of the inverter to operate the microwave while in transit will damage the alternator. Use the generator to operate the microwave while in transit.

Alternator Testing Procedure

Alternator Testing:

- ◆ Check all wiring for burnt or loose electrical connections. Repair as needed.
- ◆ Check all grounds and electrical connections to confirm they are clean and tight.
 - A. Alternator ground to chassis frame.
 - B. Motor block ground to chassis frame.
 - C. Chassis battery ground to chassis frame.
 - D. Alternator positive output to isolator relay terminal.
- ◆ **Inspect** the alternator for damage.
- ◆ Check belt pulley for wear. Replace as needed.
- ◆ **DO NOT** disconnect the battery, or battery wire, from the alternator with the engine running as this can damage the alternator or regulator.
- ◆ The pulley for the alternator should be torqued to 80 ft. lbs.
- ◆ Chassis battery voltage with the engine **OFF** should range from 12.2 to 12.7 Volt DC.
- ◆ Chassis battery voltage with the engine at idle should range 13.5 to 14.2 Volts DC.
- ◆ The output of the alternator range is 13.6 to 15.4 Volts DC. Connect a volt meter to the (B+) terminal of the alternator and chassis ground. Idle the engine up to 1200 RPM.
- ◆ Connect a clamp-on amp-meter, if available, to the positive battery cable to verify the battery state/rate of charge.

CAUTION:

The alternator is not a battery charger. The alternator is designed to maintain proper electrical system voltage. A battery with a low state of charge, or a dead battery, may overheat and damage the alternator.

STEERING COLUMN & SMART WHEEL

The steering wheel system consists of electronic modules enclosed in the steering wheel and the Master Controller typically located in the front run box. Four wires utilizing a “clock-spring” connector in the steering column accomplish communication between the steering wheel and the Master Controller. The Master Controller decodes the signal for the closed switch and operates the corresponding outputs for that function. Two additional wires provide power and ground for the steering wheel backlighting.

The 3 Amp fuse on the Master Controller is for backlighting the switch panel. LED draw is approximately 20 mA.

Another function of the smart wheel is the “High Idle” feature.

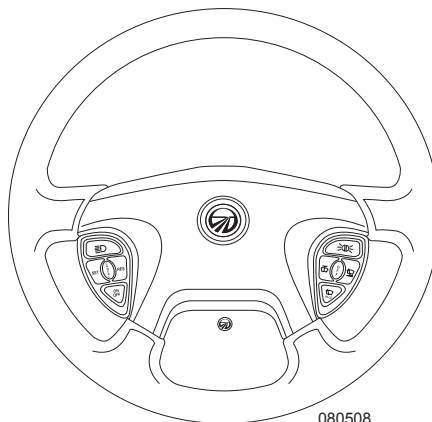

080508

Smart Wheel Operation

HORN:

The horn bar on the steering wheel sends the appropriate signal to the Master Controller causing the HORN output to activate while the switch is pressed.

HEADLAMP FLASH:

When headlights are **ON**, press and hold the switch to turn them off. When the headlights are **OFF**, press and hold the switch to turn them on.

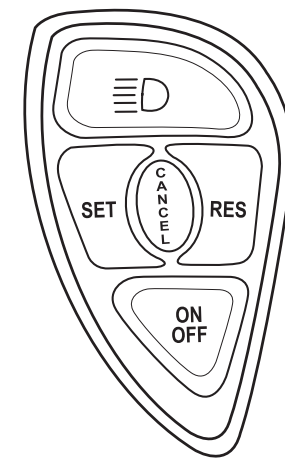

080507b

Cruise Function:

- ◆ **CANCEL** - Signals cruise system to disengage without losing the current speed memory setting.
- ◆ **ON/OFF** - Cycles cruise system **ON** and **OFF**.
- ◆ **RES (RESUME)** - Actuates cruise resume function of engine controller.
- ◆ **SET** - Actuates cruise set function of the engine controller.

WARNING:

DO NOT use cruise control in heavy traffic or on roads that are winding, slippery or unpaved. DO NOT shift the transmission into “N” (Neutral) with the cruise control on. High engine RPM run up will occur until the cruise control is turned off.

To use the Cummins High Idle Feature:

- ◆ With the cruise control **OFF** (see dash light), press and release the **RES** button. Each time the switch is pressed and released, the idle will rise 25 RPMs, from 500-800 RPM. To lower the idle, press and release the **SET** button. Engine idle speed will decrease in 25 RPM increments.
- ◆ With the Cruise Control **ON**, press and release the **RES** button once. Engine speed will increase to 1000 RPM. Push and hold the **RES** button, engine speed will increase to 1500 RPM. Use **CANCEL** or turn the cruise control **OFF** to return the engine to an idle.
- ◆ With the Cruise Control **ON**, press the **SET** button once. Engine will increase to 1200 RPM. Press and hold the **SET** button, engine speed will decrease to 800 RPM. Use **CANCEL** or turn the cruise control **OFF** to return the engine to idle.

To Use the Detroit High Idle Feature:

- ◆ With Cruise Control **ON**, push and release the **RES** button to increase RPM to 800. Repeating this procedure will raise engine speed by 25 RPM until a maximum of 1600 RPM is reached. Push and hold **RES** button to increase RPM. Hold down the **SET** button to decrease RPM. Push the **ON/OFF** button to return the engine to normal idle. The **CANCEL** button has no effect in the High Idle mode.

NOTE:

The transmission will not shift into gear if the engine RPM is at or above 900. The display will flash “6” indicating the engine RPM is excessive. Select “N” and lower the engine RPM. The brake also deactivates high idle.

Wiper Function

The windshield wipers are driven by a single motor. Any wiper function generates a Headlamp On signal from the Master Controller. To disengage automatic headlight illumination, turn off the ignition, or activate and then deactivate the dashboard headlamp switch.

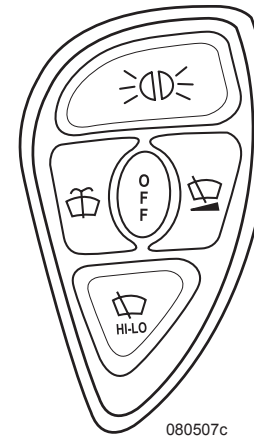
**Marker Flashlamp:**

Pressing Marker Flash lamp causes the taillights and all marker lights to momentarily flash.

**OFF:**

Cancels all wiper operations. Wiper function is also cancelled when the ignition is turned off.

**HI-LO:**

When the button is pressed, wipers activate on low speed. If the button is pressed again, the high wiper speed setting is activated. Subsequently pressing the **HI-LO** button will alternate wiper operation between low and high speed mode.

**Wiper Wash:**

Activates the wash pump relay while the button is pressed. If no wiper function has been selected, the low wiper will activate for a period of approximately three wiper cycles, after the switch is released. If any wiper functions have been selected, the wipers will continue to run in the selected mode after the wash button is released.



Wiper Variable:

Operation of the Wiper Variable button causes the low speed wiper function to activate for one wipe. If the button is pressed again within approximately 30 seconds, the low speed wiper function activates and repeats at an interval determined by the time between the last two operations of the button. Additional button operations will shorten the cycle. Activating other wiper modes cancels the variable mode.

Example: In light rain or misting conditions press the button once to initially clear the windshield. If the windshield requires a second clearing, press the button again, setting the timed interval between subsequent wipes required by the current conditions. To extend the wipe interval, press the intermittent button twice more, or switch the wipers off and use the same method to set the desired interval.

Tilt & Telescope

Tilt and telescope steering wheel control lever is located on the steering column.

- ◆ To tilt the steering wheel: Pull the lever up and tilt the steering wheel to the desired level. Release the lever to lock the steering wheel in the new position.
- ◆ To telescope the steering wheel: Push and hold the lever down. Move the steering wheel to the desired location. Release the lever to lock the steering wheel in the new position.

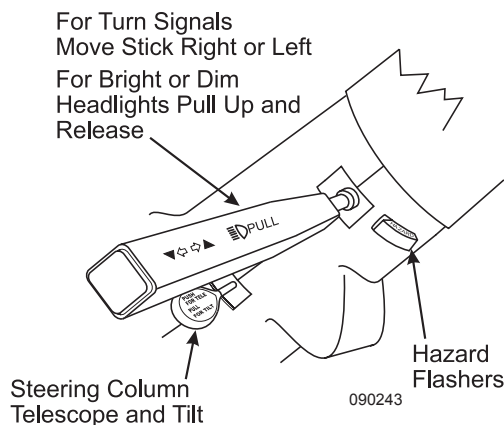

Turn indicator and headlight high/low dimmer control is located on the steering column.

- ◆ Push the lever forward to activate right turn indicator circuits when the ignition is on.
- ◆ Pull the lever back to activate left turn indicator circuits when the ignition is on.
- ◆ Pull the lever up to select high/low beam circuits when the headlights are on.

Hazard Flashers:

- ◆ The flasher button is located on the steering column.
- ◆ To turn on the four way flashers, pull **out** on the flasher button. The turn signal alarm will sound.
- ◆ To turn off the flashers, push the button **in**.

CONSOLE

NOTE:

Switch and component placement on panels may vary.

Transmission Shift Selector

The keypads on the shift control are **R** (Reverse), **N** (Neutral), **D** (Drive), Arrow up, Arrow down, Mode button. A digital display window shows gear selection, various transmission modes, oil level and transmission fault codes. Generation 4 keypads have a split screen displaying two number sets while in drive. The left number displays the highest forward range available. The right number is the range that the transmission is currently in. **NN** (Neutral) will appear in the display window when the ignition is turned On. This indicates the transmission is in neutral and it is safe to start. If the **NN** does not display when the ignition is turned on, there is no power to the shift selector and the transmission will not allow the engine to start. No display is an indicator of electrical problems with the engine batteries, ECU or the shift selector.

Keypad Functions:

- ◆ Select the Reverse gear by pressing **R**. RR will display.
- ◆ Select Neutral by pressing **N**. The area around the **N** button has a raised ridge so the driver can orient his hand to the push buttons by touch without looking at the display.
- ◆ Select Drive range by pressing **D**. The highest forward gear (6th gear) appears in the display and the transmission will shift to first gear indicated as 6 1.
- ◆ The **Up** and **Down** arrow buttons are used to select a higher (if not in “6”) or lower (if not in “1”) forward range. These buttons are not functional in Neutral or Reverse. When in Drive, one press changes the gear range selected by one. If the button is held continuously, the selected range will continue to change up or down until the highest/lowest possible range of gears is selected.
- ◆ The Mode button enables a secondary shift point to be selected. This is commonly referred to as Economy mode. Economy mode affects the upshift schedule 3-4, 4-5, 5-6 and downshift schedule 6-5, 5-4, 4-3. During highway driving, with the cruise control set between 55 and 65 m.p.h., setting the transmission to economy mode will eliminate about 99% of transmission downshifts from sixth to fifth when incurring a slight incline or overpass.

DO NOT use economy mode while traveling in mountain terrain. The lower RPM shift schedule will reduce the flow of antifreeze, lubricating oil and air flow through the radiator, resulting in increased transmission and engine temperature.

CAUTION:

DO NOT use the economy mode in heavy stop and go traffic or mountainous terrain. Frequent shifting will occur and increase transmission fluid temperature. Exit economy mode until road conditions improve.

NOTE:

When the Auxiliary Braking device is used, the display will change to a default reading of 6-2. This setting is pre-selected at the factory and can only be altered by an authorized Allison Service center. The transmission is not actually in second gear. This is only a reference point indicating the transmission will automatically downshift to second gear when auxiliary braking device is engaged.

Power Gear Control - Hydraulic Systems (Optional):

The three-point hydraulic leveling system is operated from the control module to manually or automatically level the motorhome. The control features a multiple warning system with flashing lights and an alarm to alert of a jack down.

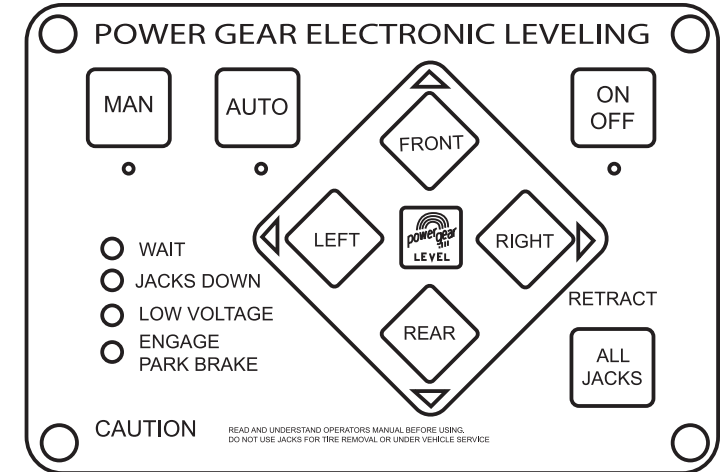

Power Gear Hydraulic Level (Optional)

020039f

Power Gear/Valid (Air or Air/Hyd Leveling):

The touch panel, computer controlled, four-point air leveling system controls air-leveling operations. The ignition must be ON in order for the leveling system to function.

NOTE:

Air leveling will NOT operate unless ignition is ON.

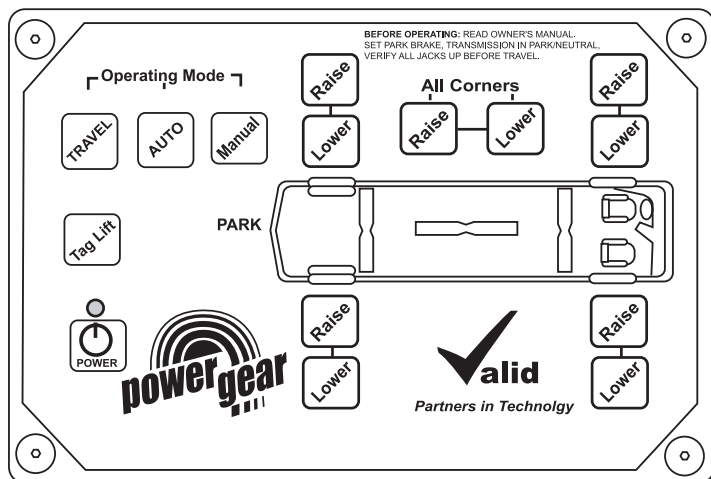

Power Gear/Valid Air Level (Standard)

020307c

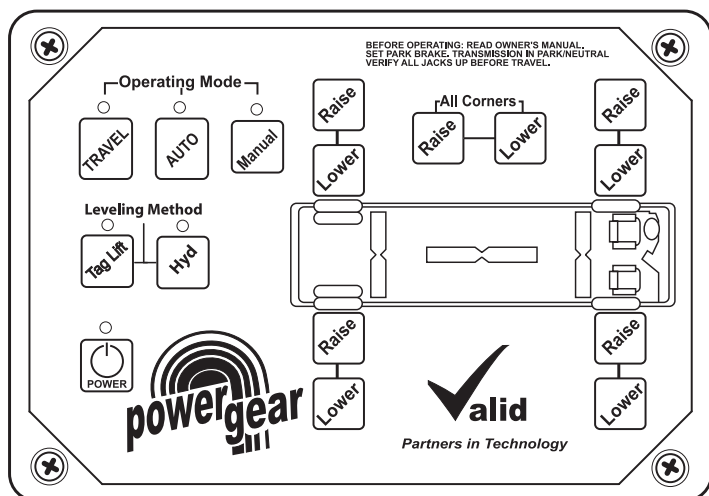

Power Gear/Valid Air/Hydraulic Level (Optional)

020307d

DASH Instrument Panel

NOTE:

Some items depicted in the illustration may vary depending on floorplans and equipment options. Gauge location may vary.

1. TACHOMETER:

Displays engine speed in revolutions per minute (RPM).

2. FUEL:

Fuel gauge will register approximate fuel level in tank when ignition switch is in run position.

NOTE:

Fuel mileage varies with driving style and road conditions. Always average more than one tank of fuel to obtain a more accurate figure. The diesel Generator and the Aqua-Hot system both use fuel from main tank and will affect fuel mileage figures. Diesel Generators and Aqua-Hot will not operate below 1/4 tank to ensure there is enough fuel to run main engine.

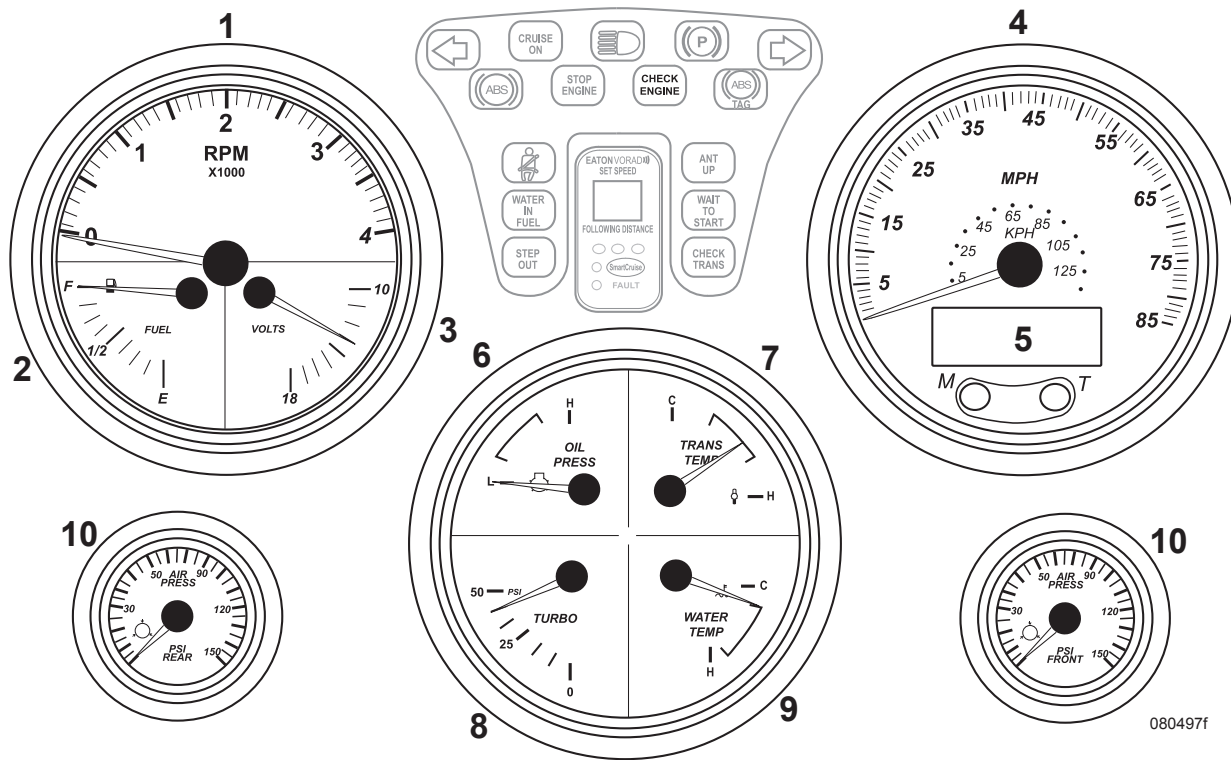

3. VOLTMETER:

Shows the charge condition in the chassis battery. The normal voltage with the ignition switch **ON** and the engine **OFF** varies between 12.0 and 13 Volts. Battery charging voltage is about 14.0 Volts when the engine is operating under a normal load. Battery readings of less than 10.5, or more than 15 Volts, usually indicate a battery or electrical system problem.

4. SPEEDOMETER:

Indicates the speed of the motorhome. The gauge indicates MPH and KPH.

5. LCD DISPLAY AND FUNCTION BUTTONS:

The first line of the LCD displays the odometer, and the second line displays the trip odometer during normal operation. A warning condition will display on the second line.

- ◆ ABS Warning
- ◆ Check Transmission
- ◆ Bay Door Open
- ◆ Low Oil Pressure
- ◆ High Transmission Temp
- ◆ Generator Door Open
- ◆ High Coolant Temp
- ◆ Low/High Battery Volt
- ◆ Low Air Pressure – Front
- ◆ Low Fuel Level
- ◆ Warning
- ◆ Low Air Pressure – Rear
- ◆ Water in Fuel
- ◆ Stop Engine
- ◆ Engine Not Running

- ◆ Headlight on alarm.
- ◆ Turn Signal

Audible Alarm:

Alerts the driver of a warning condition. The warning is displayed on the LCD.

To Change LCD Display:

The function buttons (**M** and **T**) allow access to different displays and setting changes and are displayed on the second line. Press **M** to scroll through the following options. Leave the option highlighted for two seconds to display.

- ◆ Trip Odometer
- ◆ Instantaneous Fuel Economy
- ◆ Average Fuel Economy
- ◆ Hour Meter

To make setting adjustments, run diagnostics or display engine information, press and hold the **M** button for five seconds. A menu will display on the second line of the LCD. Use the **M** and **T** buttons to scroll through the following options. Options are highlighted when selected. Press and hold both buttons to make a selection.

- ◆ **Select Units:** Choose between English or Metric units.
- ◆ **Contrast:** Adjust contrast of LCD.
- ◆ **Instrument Diagnostics:** Select instrument type to be tested. Scroll through options using the **M** or **T** button. Press and hold both to make a selection.
- ◆ **Engine Diagnostics:** Displays engine FMI codes.
- ◆ **Transmission Diagnostics:** Displays transmission FMI codes.

- ◆ **ABS Diagnostics:** Displays ABS FMI codes.

- ◆ **Read Parameters:** Displays engine statistics such as air pressure, coolant temp, RPM, etc.

To Return to main display, press and hold both buttons for five seconds.

6. OIL PRESSURE:

Indicates oil pressure, not the amount of oil in the engine. Please refer to manufacturer's instructions for specific pressure recommendations.

7. TRANS TEMP:

Shows approximate normal operating temperature of the transmission fluid. Do not let the transmission cooler oil temperature exceed OEM specifications. If excessive temperature is indicated, stop the motorhome and shift to neutral. Accelerate the engine at 1200 to 1500 RPM and allow temperature to return to normal. Refer to the Aladdin system if the needle indicates an out of range condition.

8. TURBO BOOST (0-50 psi):

Indicates boost pressure produced by the engine turbocharger.

9. WATER TEMPERATURE:

This gauge indicates an approximate normal operating range. Monitor this gauge frequently when **CLIMBING HILLS, TOWING OR TRAVELING IN HIGH AMBIENT TEMPERATURES**. Refer to the Aladdin system if the needle indicates an out of range condition. **IMMEDIATE ACTION** should be taken to avoid engine damage. Refer to the OEM instructions for specific temperature recommendations.

10. AIR PRESSURE GAUGES:

One gauge is for the front air tank and the other is for the rear air tank. The normal air system operating pressures are 110 to 135 psi. Air pressures are preset at the factory. If a problem occurs with either air system not maintaining normal operating pressure, it is an indication of a malfunction in the air system. Use caution and stop the motorhome in a safe area. Contact your dealer immediately.

NOTE:

It is not safe to drive the motorhome with low air pressure. Damage can occur to the suspension and drive shaft and also affect operation of the air brake system.

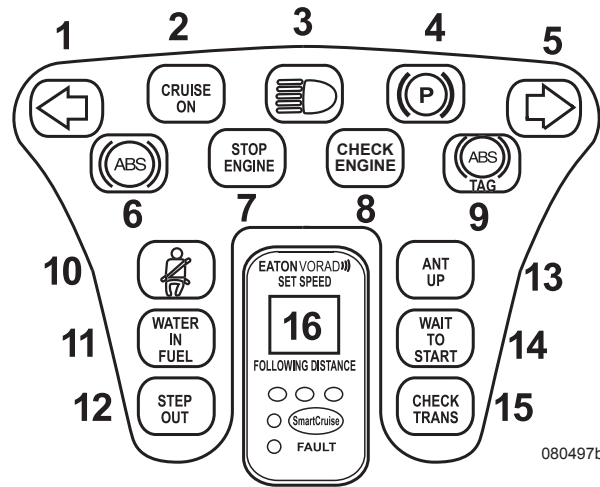
Indicator Lights**1. LEFT ARROW - Audible Turn Indicators:**

Left turn indicator circuits active. Alarm cancels when service brake is applied.

2. CRUISE ON:

Cruise Control is activated.

3. HEADLIGHT BEAM:

High beams when illuminated.

4. PARK BRAKE:

Parking/emergency brake is applied.

5. RIGHT ARROW - Audible Turn Indicators:

Right turn indicator circuits active. Alarm cancels when service brake is applied.

6. ABS BRAKE:

Indicates possible fault in the ABS Brake system.

7. STOP ENGINE:

Alerts of severe out of range condition within the engine protection circuits. Pull over and stop as soon as possible. Shut-off engine to avoid engine damage.

8. WARNING:

An “out of range” condition exists within the engine protection circuits. Stop coach and check all fluid levels.

9. ABS TAG:

N/A

10. SEATBELT LIGHT:

Stays lit and chimes for eight seconds after the key is turned **ON**.

11. WATER IN FUEL:

Water has been detected in the primary fuel filter. Purge water from filter at engine compartment.

12. STEP OUT:

Exterior entry step is extended.

13. ANT UP:

Antenna is up. Lower antenna before moving motorhome.

14. WAIT TO START:

Monitors manifold preheat. Wait for lamp to cycle off before cranking engine.

15. CHECK TRANS:

Alerts of problems related to the Allison Transmission. The light should momentarily illuminate when the ignition is switched **ON**. When starting, the lamp will extinguish indicating the circuits are working properly. If the lamp fails to illuminate or remains on, the transmission needs to be checked immediately. Contact the nearest Allison dealer.

16. VORAD SAFETY SYSTEM DISPLAY (Optional):

Displays Following distance and menu settings of the Vorad Collision Warning System.

Switches

Dash switches come either with or without a Bar Light. The Bar Light indicates the item/function is active. Icon lighting for both switch types illuminate with panel lamps.

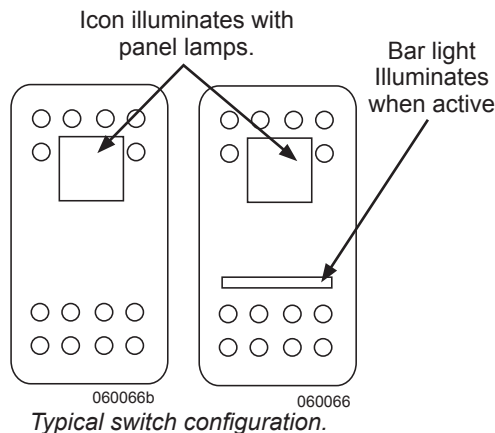
**Driver Console****SELECT MIRRORS:**

Three-way switch that controls the positions on the mirror.

T (Up): Controls the top mirror.

M (Middle): Controls the center mirror.

B (Down): Controls the lower mirror.

MIRROR ADJUST:

Use an Allen wrench to adjust the mirrors for accurate visibility. Make sure you can see out of both the driver and the passenger side mirrors before driving the motorhome. Place the Selector switch to the desired side. Use the outside directional ring to set desired angle. Place the switch in the center position to prevent accidental maladjustment.

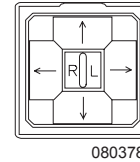
**NOTE:**

Ignition must be in the ON or ACC position.

VORAD SAFETY SYSTEM ADJUST (Optional):

Adjusts following distance, changes the menu and turns the Vorad Safety System ON/OFF.

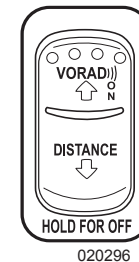
**DRVR SHADE:**

Operates the power sun visor on the driver side.

PASS SHADE:

Operates the power sun visor on the passenger side.

TAG AXLE (Optional Air & Hydraulic level only):

The tag axle button is incorporated into the air/hydraulic control panel. Pushing the **Tag lift button** will raise or lower the tag axle after a two minute ignition ON delay.

Hydraulic Level only:

Switch on driver console raises and lowers tag axle. The bar light on the switch is illuminated when the tag axle is up.

NOTE:

In certain situations, tag axle may require to be in UP position. Raise the tag axle when making sharp turns under 5 mph.

Tag Axle Switch Positions:

- ◆ Tag axle is down - bar light is not illuminated.
- ◆ Tag axle is up - bar light illuminates.

NOTE:

DO NOT drive the motorhome over 5 MPH with tag axle raised. The manufacturer will not be held responsible for any damage that may occur from driving with the tag axle raised.

PEDAL IN/OUT:

After adjusting the mirrors and steering wheel, use the Pedal In/Out switch to adjust the brake and throttle pedals. The switch on the left-hand console panel marked Pedal In/Out moves the pedals approximately three inches. When the pedals reach the end of their traveling distance the motor will stop. Release the switch.

BRAKE HI/LO:

HI = All six cylinders.
LO = Three cylinders.

**ENGINE BRAKE:**

Activates the control solenoid for the engine brake system.

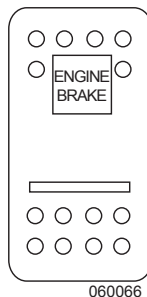
**CEILING LIGHTS:**

Turns on forward halogen lights over front seats.

STEP COVER:

The sliding step-well cover is extended and retracted at two switch locations. The second switch is located on the passenger console. Power comes from the house batteries and requires the battery cut-off switch to be on.

ATC:

Activating the ATC switch allows greater engine torque during an ATC event.

MIRROR HEAT:

Turns on the heaters in outside rear view mirrors. The mirror heaters should be used when defogging or deicing is needed. Mirror heat should not be left in the **ON** position unless continuous fogging conditions occur.

FAN HI/LO:

Operates a two-speed overhead fan for use with windshield defrosting, cooling and recirculation.

Dash Instrument Panel**HEADLIGHTS:**

Pull to first click to activate parking lights. Pull to second click to activate headlights. Headlight on alarm will sound if ignition is turned off.

**DIMMER/RHEOSTAT:**

Controls dash switch backlighting when headlight switch is on.

AIR DUMP (Hydraulic Leveling Only):

Deflates air suspension with optional hydraulic leveling.

DOCK LTS:

Operates dock lights.

BATT BOOST:

The Battery Boost switch is used if the motorhome chassis battery is too low to start the engine. Use Battery Boost to momentarily “jump” the house batteries for extra battery charge.

To Use the Battery Boost Switch:

1. Hold the switch down for ten seconds. With the switch held down, turn on the ignition key. The battery volt gauge on the dash should indicate 12 Volts.
2. If voltage is sufficient continue to hold the switch down and attempt to start the engine. If the engine does not start, the motorhome may require jump starting. See **Section 2 Driving & Safety - Dead Chassis Battery**.

NOTE:

There should be an audible click from the engine compartment when the solenoid engages.

CAUTION:

The boost switch should not be held for more than 30 seconds. Damage to the boost solenoid may occur from overheating.

FOG LIGHTS:

Operates the fog lights with the ignition key on and the headlights in the low beam position. The fog lights will go off when the headlights are switched to high beam.

GEN ON/OFF:

Starts and stops generator from the dash area.

ALADDIN™ JOYSTICK:

Selects different menus of the Aladdin™ system.

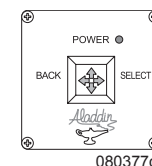

Aladdin Joystick

BLOCK HTR:

This feature warms the engine for starting in sub-freezing or extreme cold temperature. Turn the switch on to supply 120 Volt AC power to the receptacle for the block heater cord. For efficiency, hook the motorhome to shore power when using the block heater receptacle.

To Use the Block Heater:

- ◆ Hook to shore power and plug in block heater cord to the receptacle.
- ◆ Turn on the Block Heat switch.

NOTE:

It is advised to prepare the engine for starting in sub-freezing temperatures by leaving the block heater plugged in overnight.

AQUA HOT ENGINE PREHEAT

The engine preheat loop is an integral part of the Aqua-Hot heating system. In cold ambient temperatures, use this feature to preheat the engine. The Aqua-Hot also supplies supplemental heating to the interior using heat created by the engine. While traveling, the water pump on the engine will pass coolant through the Aqua-Hot system. When using the supplemental heating feature, use the Comfort Control thermostat to activate the desired heat exchangers.

To Enable Engine Preheat:

- ◆ Turn the Aqua-Hot switch on at kitchen.
- ◆ Turn the Aqua Hot Engine Pre-Heat switch **ON** to activate the engine preheat circulation pump. Circulating engine coolant through the engine pre-heat loop will adequately warm the engine to operate for easy starting.
- ◆ Allow approximately one to two hours (longer for colder, ambient temperatures) of engine preheating run time. The pump can be operated overnight if desired.
- ◆ Turn the engine heat switch **OFF** when engine preheating is not desired.

Passenger Console**CEILING LIGHTS:**

Turns on forward halogen lights over front seats.

PASS SHADE:

Operates the Passenger Side power sun visor.

STEP COVER:

The sliding step-well cover is extended and retracted at two switch locations. The second switch is located on the driver console. Power comes from the house batteries and requires the battery cut-off switch to be on.

NOTE:

Layouts may vary with difference in models and options.

BAY LIGHTS:

Turns bay lights on and off.

BATTERY CUTOFF:

Turns house battery power on to 12 Volt domestic fuse panels.

STEP:

Turns power on or off to step. To leave the step extended when parked, open the door. After the step extends, turn the switch off.

GRAB H/STEP W:

Turns grab handle and step well lights on and off.

PORCH LIGHT:

Turns porch light on and off.

DASH AIR CONDITIONER & HEATER CONTROLS**Dash AC and Heater Control:**

Designed to provide heating, cooling and defrost capabilities for the pilot/co-pilot area. The system is not capable of heating or cooling the entire motorhome.

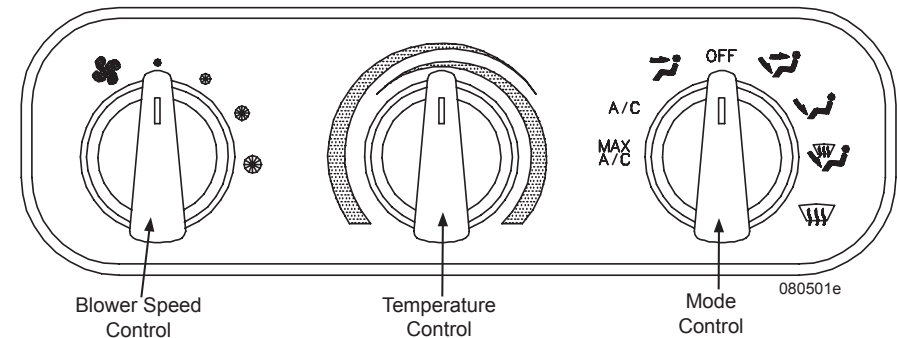
**Blower Control Switch:**

This switch controls the four speeds of the blower motor. This is one of the most effective ways of controlling temperature. The Mode Control Switch must not be in the OFF position in order for the blower to activate.

Temperature Control Switch:

Setting the switch to the **red** zone controls an electric water valve regulating the amount of engine coolant passing through the heating coils in the system. Rotating to the **blue** zone sets the cut-in/cut-out temperature of the air conditioning compressor on the engine.

Mode Control Switch:

This switch directs air flow by opening or closing damper doors. Use the Mode Control Switch to direct airflow where it is needed to maximize comfort in the cockpit area.

NOTE:

The air conditioning compressor is activated when using MAX A/C, A/C, MIX and DEFROST.



FLOOR - Fresh air is drawn in and discharged through the floor louvers.



MIX - Fresh air is drawn in and discharged through the floor and defrost louvers. The A/C system operates to dehumidify the discharged air.

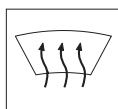

090273 - 277

DEFROST - Fresh air is drawn in and discharged through the defrost louvers. The A/C system operates to dehumidify the discharged air.

MAX
A/C

MAX A/C - Recirculated air is drawn from the passenger area and discharged through the dash louvers.

A/C

A/C - Fresh air is drawn from outside into the system and discharged through the dash louvers.



VENT - Fresh air is drawn in and discharged throughout the dash.

OFF

OFF - The blower motor does not operate. The fresh air inlet door will close, minimizing outside air infiltration into the motorhome.



BI-LEVEL - Fresh air is drawn in and discharged through the dash and the floor.

A/C Operation:

The A/C dash system will operate in all modes except **BI LEVEL**, **FLOOR** and **OFF**. When the Mode Control Knob is positioned in the A/C mode, fresh air is drawn through the front air intake of the unit through the A/C coil. The Mode Control Knob in the **MAX A/C** position closes off a damper door to outside air and recirculates air from inside the motorhome. Select this position when maximum cold air is desired or to keep outside air from entering the motorhome.

Heat and Defrost Operation:

- ◆ Set the Mode Control Switch to the desired position.
- ◆ Set the Temperature Control Switch to the red zone.

Operating Tips & Hints

Air intake and discharge temperatures are greatly affected by ambient temperatures and relative humidity. A large amount of cooling capacity is used to dehumidify as well as cool air. After three to five minutes of A/C operations, discharged air temperature should be approximately 20°-30° F cooler than the fresh or recirculated air entering the A/C system.

Winter Use:

- ◆ De-ice the windshield using the **DEFROST** mode.
- ◆ Air will heat up faster with a slower blower speed until normal operating temperature ranges are reached.

Summer Use:

- ◆ Close all windows and vents to hot, humid outside air.
- ◆ The recirculation blower provides quick cool down.
- ◆ Use a lower blower speed to produce cooler air.

Heater:

The heater warms the air in the dash area. Much like the refrigeration side of the system, a liquid will be used in the process. This liquid is the engine coolant. The coolant is passed from the radiator to an electronic water valve. The water valve, when open, will allow the coolant to flow through the heater core. The heater core is much like a miniature radiator. Air is drawn into the system by a blower motor through the outside recirculation door opening. Air is blown through the A/C evaporator core and then through the heater core. When the temperature control is in the **WARM** position coolant flows through the heater core. When the temperature is in the **COOL** position coolant flow bypasses the heater core. In either position, the airflow is felt at the discharge vents.

Electric Water Valve:

The water valve controls the water flow to the heater core. A control module compares the output voltage from the thermostat to the feedback for the stepper motor of the water valve. The control module then drives the motor to within one-half volt of the control thermostat voltage.

Functional Test:

- ◆ Start and operate the engine until the water reaches normal operating temperature.
- ◆ Set the HVAC temperature control to the full hot position.
- ◆ The discharge air outlets should have hot air.
- ◆ Rotate the temperature control to full cold position.

- ◆ Allow 10 minutes for the temperature to stabilize.
- ◆ The discharge air outlets should have cold air.

System Components

Compressor - The compressor is belt driven from the engine through the compressor and electronic clutch pulley. The compressor will pump freon from a low-pressure gas into a high-pressure, high-temperature gas. This is the start of the refrigeration process.

Condenser - The condenser is made of coils and fins which provide rapid transfer of heat from the refrigerant as external air passes over the coils. The high-pressure gas is changed to a high-pressure liquid.

Condenser Fan - A steady flow of cooling air is maintained across the condenser during system operations.

Receiver-Drier - Freon leaves the condenser, enters the receiver-drier and is stored until needed. The drier filters out moisture in the system. It only takes one drop of moisture to cause a malfunction in the cooling unit.

Expansion Valve - The expansion valve suppresses the refrigerant into the evaporator according to the cooling requirements. The pressure is reduced in the restrictive effort of the expansion valve. A part of the valve is the capillary tube assembly. The capillary tube is the sensing bulb at the outlet of the evaporator.

Evaporator - A tube core and fins are used in the evaporator similar to the condenser. Air is blown through the fins to allow the evaporator to cool and reduce pressure.

Blower and Motor - The evaporator has a fan called the blower. The blower will draw air from the cab area and force the air over the evaporator coils and fins. This forced air will ensure continuous vaporizing of the R134a.

Relays and Switches - Both electronic and vacuum switches are used in the control and operations of the system.

Vacuum Generator - The vacuum generator is important to the operation of the dash heating and A/C systems. This provides the vacuum to open and close the vacuum switches. The vacuum generator creates 15 inches of vacuum that is passed to a reservoir ball. Most dash heater and A/C systems will only require 10 inches of vacuum to operate the switches. The output from the reservoir is sent to the vent control knob. The control knob will then direct the vacuum operation to the appropriate vacuum switch to open or close vents and switches. When the ignition is on and the A/C is operating, the vacuum generator will operate.

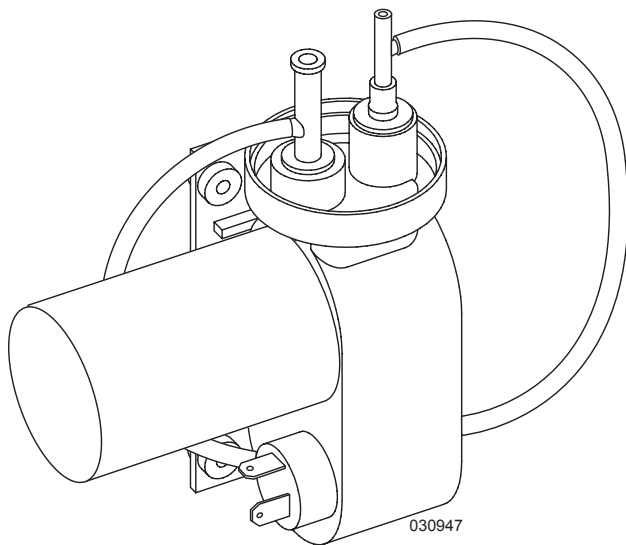

Vacuum Generator: Located at front firewall.

Troubleshooting

The dash A/C and Heat system uses a combination of compressed air (developed by the chassis system), vacuum air (developed by the vacuum generator) and electric relays and vacuum switches. Therefore, any repair can be classified in one of five categories:

- ◆ Electrical Vacuum
- ◆ Air Conditioner
- ◆ Heater
- ◆ Defroster

No Cooling:

1. Check that the blower is operating, A/C switch is in A/C or **MAX A/C** position, temperature control is turned to **MAX** cooling (blue area).
2. Verify system fuses are not blown.
3. Verify condenser fan is operating.
4. Check power supply to unit and grounding of system.
5. Check wiring.
6. Coolant valve is leaking.
7. Drive belt is loose or broken.
8. Compressor Clutch is inoperative, will not engage.
9. Expansion Valve is faulty or frozen.
10. Thermostat control is faulty.
11. Mode control switch is faulty.
12. Compressor is faulty.
13. Loss of refrigerant.

NOTE:

An ultraviolet or UV Blue Light cube is used for leak detection when dye is introduced to the A/C System.

Reduced Cooling:

1. Coolant valve not operating correctly.
2. Air passages are obstructed.
3. Loose or worn drive belt.
4. Check blower and select switch.
5. Thermostat control valve is faulty.
6. Expansion valve is faulty.
7. Compressor is faulty.
8. Low refrigerant charge.

No Heating:

1. Verify A/C switch is turned off.
2. Verify blower switch is turned on.
3. Verify the proper engine coolant level.
4. Verify that the engine is reaching operating temperature.
5. Verify engine coolant is reaching water valve attached to unit.
6. Verify operation of water valve to permit engine coolant to pass through valve to heater core.
7. Check unit fuses.
8. Check power supply to water valve and grounding.
9. Check wiring.
10. Engine thermostat faulty.

Blower Does Not Operate or Runs Slow:

1. Check fuses.
2. Check for loose or corroded connection.
3. Check wiring.
4. Check to ensure ignition switch is on.
5. Check blower and select switch.
6. Motor shaft has seized.
7. Blower wheel is out of alignment.

Damper Doors DO NOT Operate:

1. Does the motorhome air tank have pressure?
2. Is the vacuum generator being powered and producing a vacuum?
3. Check the vacuum line entering the unit for vacuum.
4. Check that the vacuum solenoid mounted on unit is receiving power from the mode switch. If operating properly, the vacuum solenoid will feel hot if current is engaging the solenoid.
5. Check the mode switch.
6. Check wiring.
7. Check for a pinch in the vacuum line leading to the vacuum motor that operates the damper door in question.

◆ **Hydraulic Level Sensor (Optional):**

Monitors level conditions of the motorhome and sends that information to the Hydraulic Leveling Control Module mounted in the driver’s console.

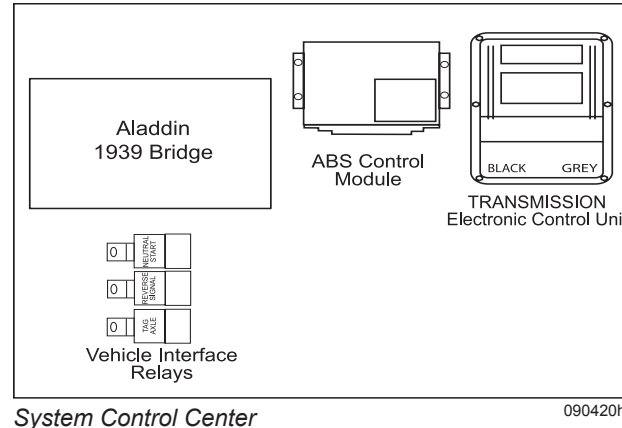

Engine Diagnostics:

The engine diagnostics will notify the operator of deviations from the programmed limits of the engine through the “Check Engine” lamp in the dashboard. Should a system component with the engine develop a deviation, the “Check Engine” lamp will illuminate and a diagnostic code will be logged and stored in the system memory. These codes are accessed by a service technician using special equipment.

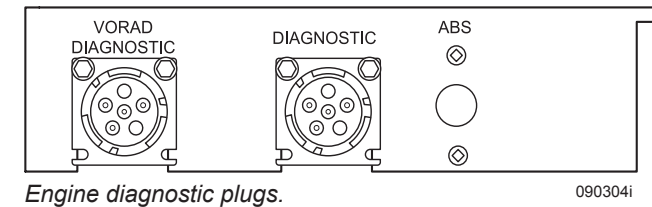

SYSTEM CONTROL CENTER

The System Control Center (located behind the overhead access panel between the rails of the bay compartment) consists of the following components:

- ◆ **Engine Vehicle Interface Relays & Transmission Electronic Control Unit (ECU):** Electronically monitors and controls engine and transmission functions and operating conditions.
- ◆ **ABS/ATC Control Module:** The ABS/ATC controller monitors road speed of each wheel, braking conditions and ABS functions.

DIAGNOSTIC PLUG LOCATION

The ABS and Engine/Transmission diagnostic plugs are located under the dash on the left side of the steering column. There is also an Engine/Transmission diagnostic plug located in the engine compartment on the curbside.

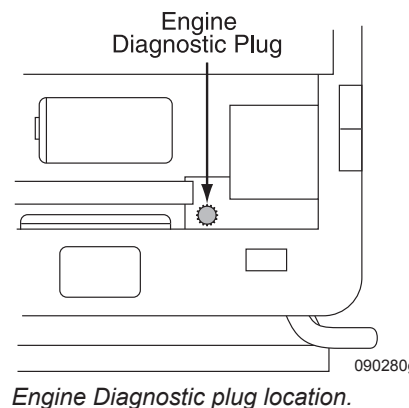

ALADDIN™ ENGINE DISPLAY

The Aladdin System will display engine and transmission statistics at a quick glance. Four additional engine and transmission screens can be accessed. These screens can be set to a rolling display, or use the joystick to pick an individual screen.

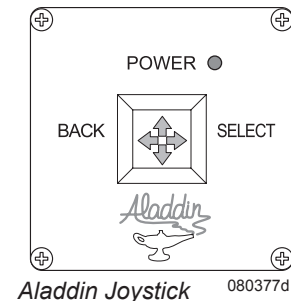

NOTE:
The backup camera and engine/transmission screens cannot simultaneously display.

To Display Engine and Transmission Status: ENGINE "NO START" - FLOW CHART

Use the joystick to enter the **Engine/Trans Status** screen from the **Main Menu**. After entering the **Engine/Trans Status** screen, move the joystick right to view the back up camera and right again for a rolling display of the four sub-screens. Move the joystick up/down to select the desired sub-screen.

MAIN MENU

- > ENGINE/TRANS STATUS
- COACH ELECTRICAL STATUS
- COACH TANK/MISC STATUS
- TRIP METER SELECTION
- TIME/ALARM FUNCTIONS
- SELECT VIDEO SOURCE
- SYSTEM OPTIONS
- POWER DOWN ALADDIN

SW 225	11:55 AM
ENGINE	TRANS
0.0 MPH	57 F TEMP
5 RPM	
59 F TEMP	
0 PCT LOAD	
0 PSI OIL	BATTERY
0.5 PSI BOOST	12.0 VDC
0.0 MPG	
	CAMERA >

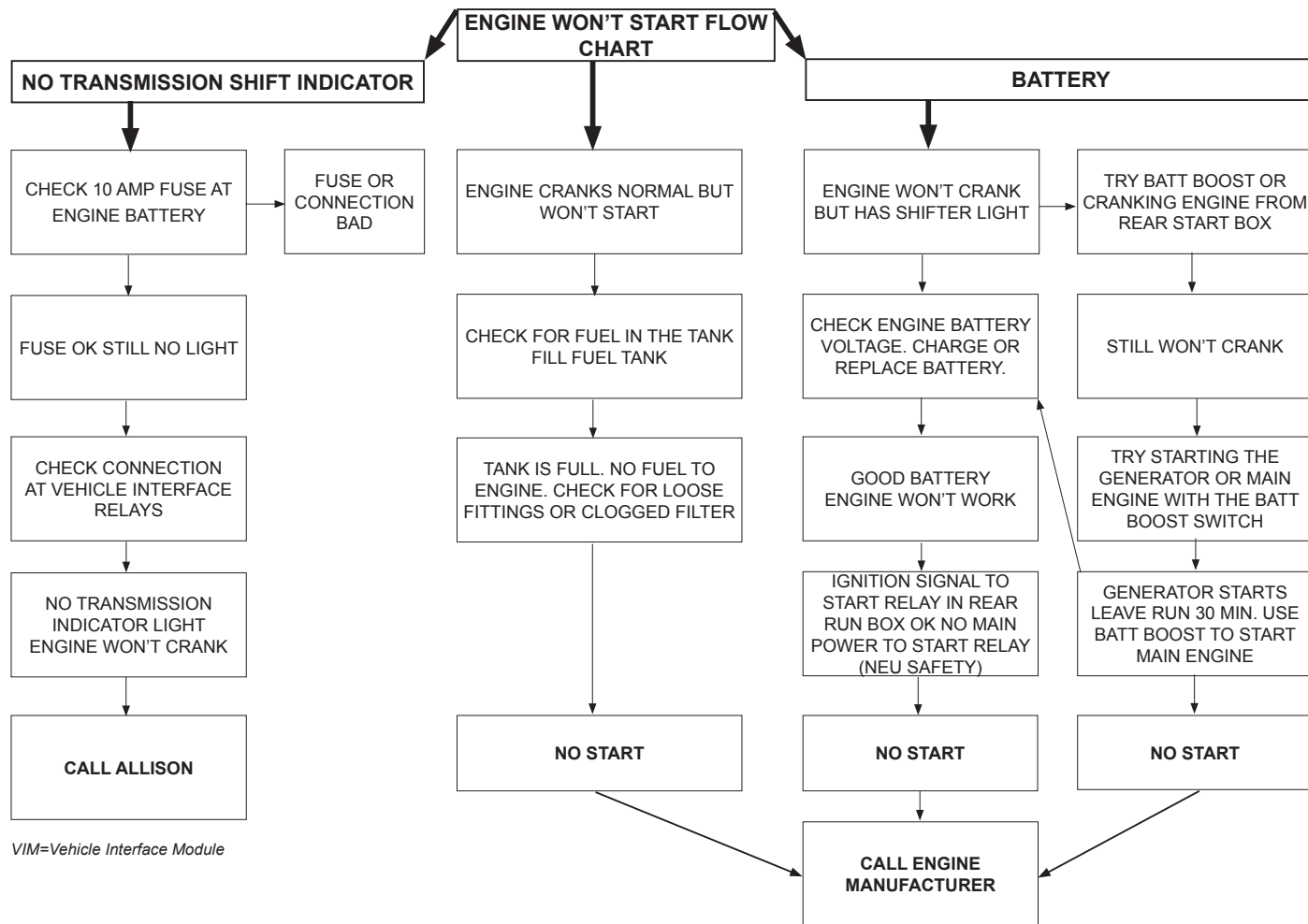

VIM=Vehicle Interface Module

THE EXECUTIVE 07

CHASSIS INFORMATION – SECTION 10

CHASSIS - INTRODUCTION	216	AIR LEVELING	232	FUEL SYSTEM	252
AIR SUPPLY SYSTEM	216	Automatic Air Leveling.....	233	Fuel Requirements.....	252
Air Governor	217	Manual Air Leveling.....	233	Fuel Tank.....	252
Air Storage Tanks	217	Travel Mode	234	Fuel Sender.....	253
Air Fittings.....	218	LEVELING - AIR /HYDRAULIC (OPT)	234	Fuel Lines & Hoses	254
Air Coupler - Universal	218	Hydraulic Automatic Leveling	234	Fuel Filters	254
Air System - Charging (External).....	219	Hydraulic Manual Leveling.....	235	HYDRAULIC SYSTEM	255
AIR DRYER	219	LEVELING - HYDRAULIC (OPT)	236	Hydraulic Pump	255
Desiccant Cartridge.....	220	Prior to Leveling	237	Hydraulic Cooler	255
Desiccant-Type Air Dryer.....	220	Manual Leveling	237	Hydraulic Fan System.....	256
Air Dryer Cycle.....	221	Automatic Leveling.....	238	Therموالve (ISM & Series 60 Engines).....	256
AIR SPRING INSPECTIONS	221	Retracting Leveling Jacks	238	Electric Therموالve (ISX Engine)	256
HEIGHT CONTROL VALVES	221	ENGINE - GENERAL INFORMATION	240	Switching Valve.....	256
BRAKE SYSTEMS	222	ENGINE DIAGRAM	240	Electric Override (ISM only)	257
Air Brakes	222	Cummins - ISM - II Standard	240	Fan Motor	257
Park & Emergency Brake System	222	Cummins ISX (OPT)	241	Hydraulic Filter	257
Brake Adjustment/Slack Adjuster	222	Detroit Diesel (OPT)	241	Hydraulic Reservoir.....	257
Brake Systems - Backup	223	STARTING PROCEDURE	242	AIR FILTER	257
ABS/ATC SYSTEM (ANTI-LOCK BRAKES)	223	Normal Starting.....	242	Changing the Filter	257
FRONT AXLE	225	Cold Weather	242	Air Filter Minder.....	257
Alignment	226	ENGINE OIL	243	EGR FILTER (DETROIT ONLY)	258
Lubrication Maintenance Safety.....	227	ENGINE SHUTDOWN	244	LUBRICATION MAINTENANCE	258
Steering Components.....	227	Extended Engine Shutdown	245	LUBRICATION CHARTS	260
Steering Column	227	COOLANT SYSTEM	245	Cummins ISM	260
Drag Link	228	Radiator/Charge Air Cooler	246	Cummins ISX (OPT)	262
Center Link	228	BRAKE - AUXILIARY (ENGINE BRAKE)	247	Detroit Diesel Series 60 (OPT)	264
Steering Spindles	228	TRANSMISSION	248	ENGINE DRIVE BELT DIAGRAM	266
Control Arm Bushings	228	Check Trans Indicator.....	249	SPECIFICATIONS CHARTS	266
STEERING GEAR	228	Periodic Inspections	250	Tank Capacities	266
DRIVE AXLE & DRIVE SHAFT	229	TRANSMISSION FLUID & FILTERS	250	Engine Specifications	266
TAG AXLE	231			Chassis Fluid Capacities.....	267
Oil Change Intervals	231			Generator Specifications	267
DRUM BRAKE LUBRICATION	232			Belts & Filters.....	267
SHOCK ABSORBER	232			BATTERY SPECIFICATION CHARTS	268
				Maintenance Records	269

CHASSIS - INTRODUCTION

This section contains information and instructions regarding various components of the motorhome chassis. Follow the guidelines and procedures to help understand and operate the motorhome. Complete instructions for engine and transmission are located in their respective operator's manual included in the Owner's Information File Box.

WARNING:

When welding is involved for motorhome repair or modification, only qualified, experienced technicians should weld on the chassis. Improper welding procedures and materials may weaken the assembly or result in damage that is not obvious and may not cause an immediate problem or failure. Unauthorized modifications or repairs to the chassis could result in a forfeiture of warranty coverage.

DANGER:

Due to the sensitive nature of the electronics on the chassis, the following precautions are required to protect electrical components in the motorhome chassis:

- 1. Disconnect the (+) positive and (-) negative battery connection.**
- 2. Cover electronic control components and wiring to protect from hot sparks.**
- 3. Disconnect the terminal plugs from the engine Electronic Control Unit, located on the curbside side of the engine block.**

- 4. Disconnect all the plugs from the transmission Electronic Control Unit, located in the storage bay between the frame rails.**
- 5. Disconnect the wiring from the alternator.**
- 6. DO NOT connect welding cables to electronic control components.**
- 7. Attach the welding ground cable no more than two feet from the part to be welded.**

The Roadmaster chassis is a semi-monocoque design using all tubular steel. The semi-monocoque design provides greater structural integrity and overall uniform stress distribution. Incorporated in the Roadmaster chassis is the exclusive cushion air glide suspension system using eight outboard and two inboard mounted air springs and 10 Bilstein shock absorbers.

The location of the air springs and shock absorbers combined with the semi-monocoque chassis provides the smoothest ride, best handling and trouble free service while delivering top notch drivability. The chassis has a three-point hydraulic leveling system or an air leveling system or both.

The front and drive axles are affixed in the chassis with trailing arms in a parallel four link arrangement while the tag axle uses leading arms. A panhard bar attached to the axle and frame prevents side motion of the axle in the chassis. The front and drive axles are mounted to a wide platform H-frame that carries the coach body on 8 outboard mounted air springs, four front and four rear. The tag axle uses two in-board mounted air bags. Suspension bushings require no lubrication for ease of maintenance. Unlike suspension that uses springs, the air

suspension system automatically maintains the same attitude and ride height throughout the entire load range.

The towing receiver is rated at 10,000 lbs. towing weight and 1,000 lbs. tongue weight.



Tag located on curbside frame behind front wheel and in generator compartment. 100168b

AIR SUPPLY SYSTEM

The air compressing system on the motorhome includes: a compressor, governor, dryer, front tank and rear tank. The compressed air system operates several items, including brakes, suspension, air horns, air gauge and the stepwell cover. The air system is charged by a gear driven air compressor mounted on the engine. As engine speed increases, compressed air output increases. When the air is compressed, heat is generated. Heat dissipates as the air is discharged from the compressor. Moisture condenses in the compressed air as it cools and enters the air dryer to be filtered. The filtered air charges the front air tank, which is divided in to a wet and dry side. The compressed air enters the wet side before entering the dry side. A discharge line from the dry side of the front air tank charges the rear air tank. Discharge lines use in-line check valves to prevent a back flow of compressed air.

The pneumatically operated items are divided into two categories: brakes and accessory air. Brakes have full use of supplied air pressure. Accessory air items, such as the air horns, receive air through **pressure protection valves (PPV)**. The PPV will not allow compressed air flow until the system reaches approximately 60 psi. In the event of an air system problem, the pressure protection valve will leave a reserve air charge for braking. The pressure protection valve is installed for safety.

Air Governor

The air governor, located in the engine compartment, regulates the air compressor to cut-in and cut-out, keeping the air system in the specified operating range of 110 to 135 psi and sending an air “purge” signal to the Air Dryer.

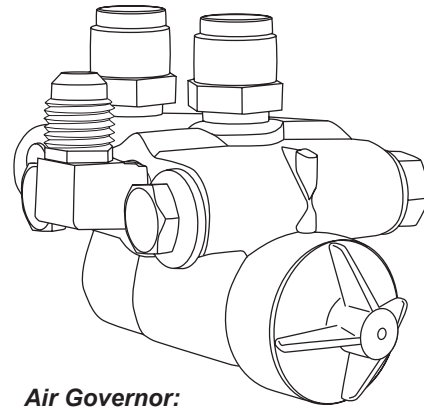

Air Governor:
Mounted curbside in engine compartment

When cut-out pressure is reached, the governor will send an air purge signal to the Air Dryer. This opens the purge port of the Air Dryer, expelling moisture. The purge action of the Air Dryer is identified by the short release of air at the rear of the motorhome.

Air Storage Tanks

The front and rear air tanks should be manually drained once a month, or more depending on operating conditions where humidity is high. The front air tank has a drain valve for both the wet and dry side. The rear air tank only has one drain valve. Open the drain valves until all air is purged from the tanks, allowing five extra minutes for moisture to expel. Remember to close the tank drain valves. Both air tanks have a pressure relief valve that is set to release at approximately 150 psi.

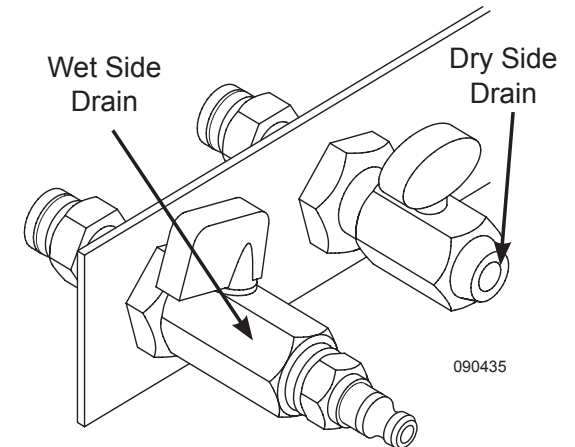
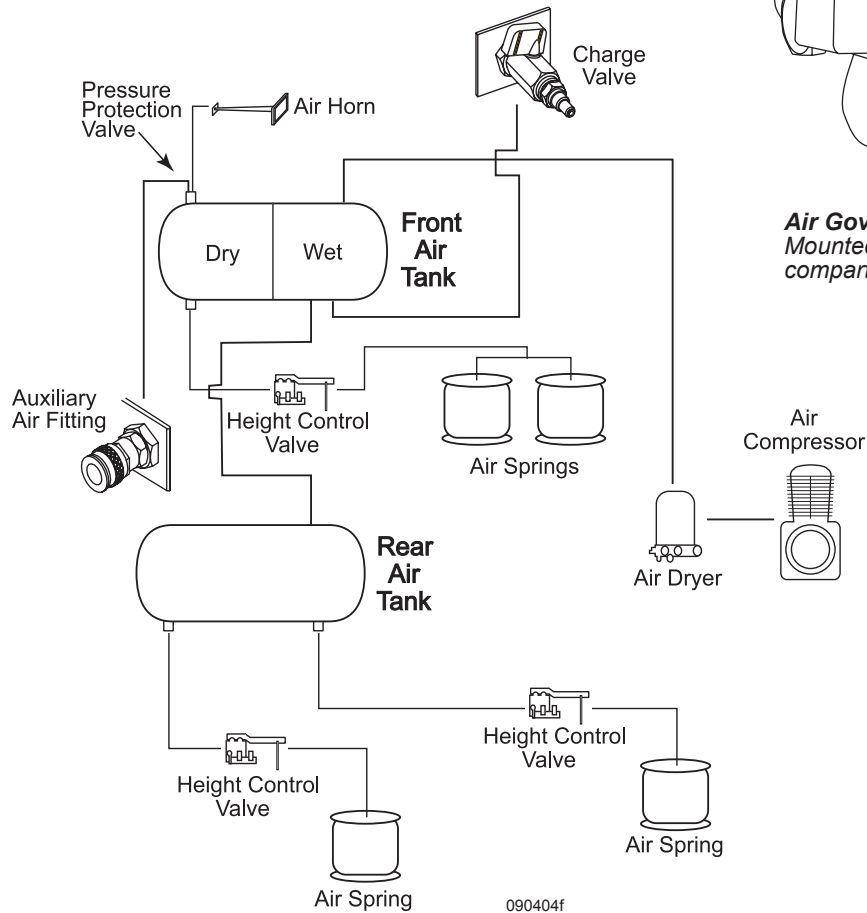

Front Tank drains are located in generator compartment on curbside. Rear Tank Drain is located in engine compartment.

Air Fittings

Push-in fittings, used to connect air hoses between pneumatically operated items, are designed for quick and easy maintenance and repair. Sizes and types of fittings vary for different applications. Threaded fittings adapt the push-in fittings to connect pneumatically operated items. Main parts include the release ring, locking ring, solid brass body and special rubber compound O-ring. Damaged hoses can be repaired by splicing.

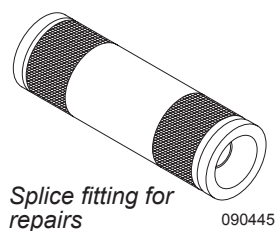

To Connect Hose:

- ◆ Push hose into fitting through the release ring and the O-ring. Use a slight twisting motion to seat firmly against the internal tube stop.
- ◆ Pull hose away from fitting to expand and set inner seal. Ensure hose is properly retained in fitting.

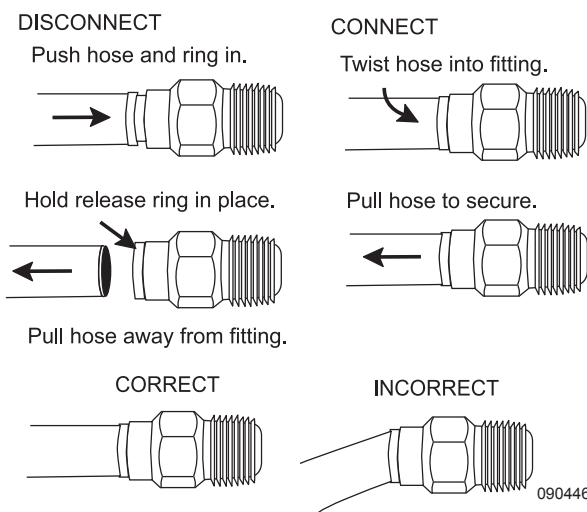

NOTE:

When putting air hose back into fitting, be sure that hose is cut as squarely as possible so that the hose will evenly seal in the fitting. The cavity of the positive tubing stop provides support to prevent leakage.

WARNING:

DO NOT remove air hoses from fittings while system is pressurized. Serious injury may occur.

WARNING:

Never place yourself under motorhome without first properly blocking frame (jackstands) from coming down in case of rapid deflation of air system.

Air Coupler - Universal

A remote air supply coupler, provided for convenience, is located in the roadside compartment behind the front tire. The universal female fitting will accept several types of 1/4" ID male air fittings, including type C automotive. The auxiliary air fitting may be used to inflate tires, air mattresses or other pneumatic items. This fitting is not designed to charge the air system on the motorhome. The air supply for the auxiliary air fitting is charged from the front air tank through a pressure protection valve.

To Use the Universal Air Coupler:

- ◆ Remove the plastic protective dust cap.
- ◆ Using a firm grip, insert the air fitting into auxiliary air supply. The locking collar is spring loaded and will automatically lock when the fitting is properly inserted.

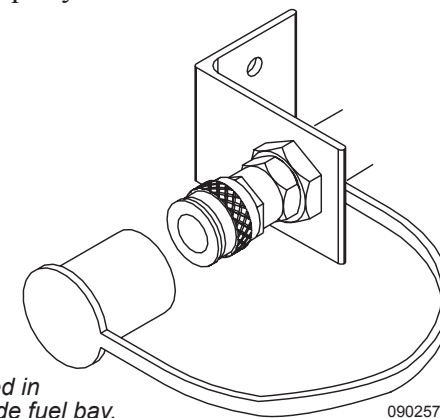

Located in roadside fuel bay.

To Disconnect Hose:

- ◆ Push hose into fitting.
- ◆ Push release ring down against locking ring portion of the fitting body.
- ◆ While holding the release ring down, pull hose away from fitting.

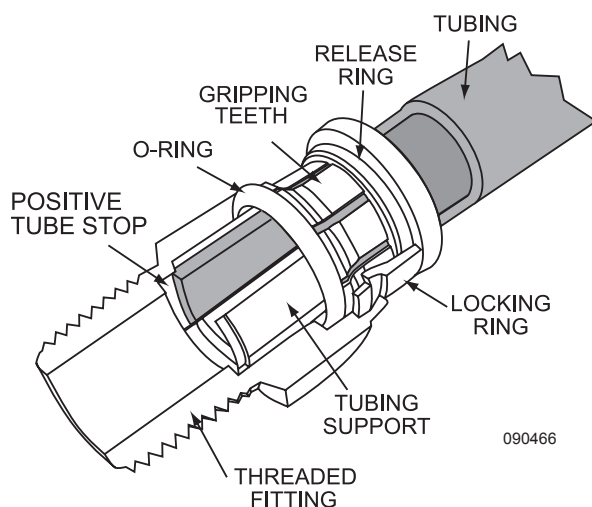

Cut-away of push-in fitting.

To remove fitting:

- ◆ Firmly grip the air hose near the fitting to prevent recoil.
- ◆ Slide the locking collar back to release fitting. The collar will lock into the open position when fully retracted.
- ◆ Replace the protective dust cap when finished.

NOTE:

Due to air pressure restrictions in the pressure protection valve and tire stem valve, the maximum amount of tire pressure achieved when the system is used to fill a tire is approximately 115 psi with the air system on the motorhome charged to 130 psi. Maximum outlet air pressure is achieved when the air system completes the fill cycle indicated by the purge cycle of the air dryer. Use a short hose to reduce tire fill time.

Air System - Charging (External)

The air system on the motorhome can be charged from an external air supply source. Located in the generator compartment is a type C automotive male fitting (also used as the front tank's wet side drain). Caution should be used when charging the air system from this fitting. The air supplied

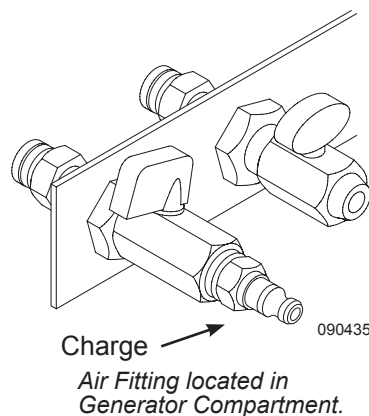

from an external source may contain moisture. Compressed air introduced into the air system on the motorhome from this fitting is not filtered by the air dryer. The auxiliary air charge fitting will charge the front and rear air tanks. A shut-off valve is installed to prevent air from escaping.

CAUTION:

The external air supply source should be regulated to charge the air system on the motorhome no higher than 140 psi. Damage to the air system or pneumatically operated items may occur.

AIR DRYER

The air dryer, located between the frame rails next to the transmission, removes moisture from the compressed air system to prevent freezing of brakes or other pneumatically operated items. The three functions of the air dryer are cooling, filtering and drying the system air. This prevents valve and seal damage or wash away of lubricants as well as freeze damage to the system components.

Air Dryer Cycle:

The governor turns the compressor on when the supply tank pressure drops below cut-in pressure. Compressed air then passes into the air dryer at the inlet port. Moisture-laden air and contaminants pass through the desiccant. Moisture is retained by the desiccant and collects in the base of the dryer. When the compressor reaches cut-out pressure (approximately 130 psi) the purge valve opens and the dryer purges and expels water collected in the dryer base. The regeneration valve opens sending a small charge of dry system air from

the front air tank back through the dryer. The backflow dries the desiccant, preparing it for the next cycle.

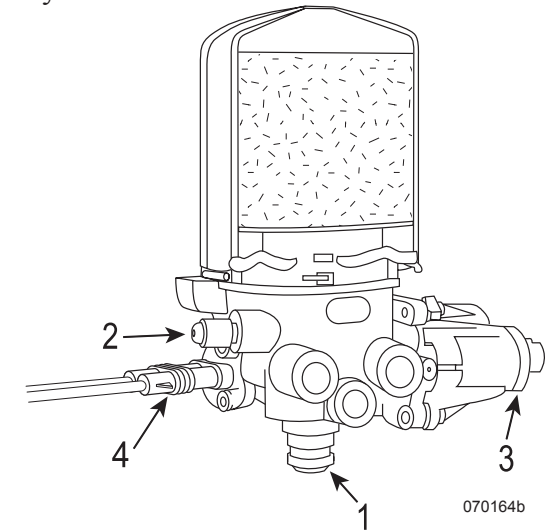
**Air Dryer Components:**

- 1. Purge Valve:** A valve located on the bottom of the air dryer base that remains open during a compressor unload cycle to allow collected moisture, condensation and contamination to expel from the air dryer during the purge cycle.
- 2. Pressure Relief Valve:** Protects the air dryer from over-pressurization.
- 3. Regeneration Valve:** Controls regeneration of the desiccant by allowing air from the supply and secondary tanks to bypass the outlet check valve.
- 4. Heater Power Connection:** Provides 12 Volt DC power to the heating element.

In extreme cold, verify that the air dryer heater is in good working order. The 100-watt heater in the air dryer is controlled by ignition power. The heater turns on below 45° F and off when the air dryer temperature is above 86° F. The circuit breaker for the heater is located in the rear electric bay.

WARNING:

Remove all pressure from the air system before disconnecting any component, including the desiccant cartridge. Pressurized air can cause serious personal injury.

Desiccant Cartridge

Warm, humid air from the compressor condenses into either water or water vapor. A desiccant-type air dryer protects the air brake system by drying moisture-laden air before it passes through the air reservoirs and into the brake system. The replacement kit contains one cartridge and one O-ring.



Located roadside by drive axle.

NOTE:

If the seats are damaged so badly that a tight seal cannot be maintained, replace the air dryer.

4. Install a new O-ring.
5. Lubricate the O-Ring on the stem with a thin layer of grease.
6. Lubricate the cartridge seal with a thin layer of grease.
7. Thread the replacement cartridge onto the base until the seal touches the base. Tighten the cartridge **ONE** additional turn. **DO NOT OVERTIGHTEN.**

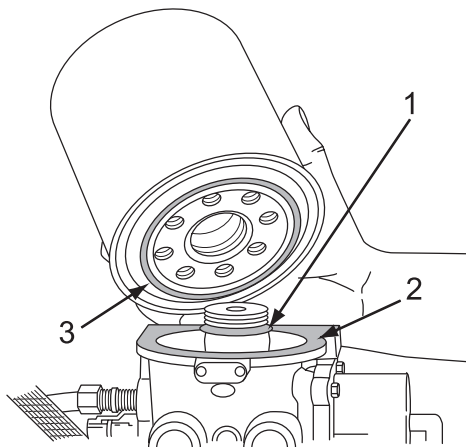

1. O-Ring
2. Seal Seat
3. Cartridge Seal

NOTE:

If an excess amount of water is present when performing the monthly air tank drain service, the filter for the air dryer may need to be changed.

Desiccant-Type Air Dryer

1. Warm, humid air from the compressor condenses into either water or water vapor before entering the air dryer.
2. A desiccant-type air dryer protects the motorhome air brake system by drying moisture-laden air before it passes through the air reservoirs and into the brake system.
3. Water collects in the base of the dryer when warm air condenses the water before it enters the dryer, or inside of the dryer before the water reaches the desiccant.
4. The desiccant material then removes additional water vapor, further drying the air.
5. During regeneration phase, the regeneration valve and pressure-controlled check valve remove water from the desiccant bed with a backflow of dried, expanded system air.

To Replace the Cartridge:

1. Loosen and remove the old cartridge. Use a strap wrench, if necessary.
2. Remove and discard the O-ring from the dryer base.
3. **Inspect** and clean the seal seat. Repair any minor damage.

REPLACEMENT REQUIREMENTS

Components	When to replace?	Why?
Desiccant Cartridge	<ul style="list-style-type: none"> • Every two to three years. • When compressor is replaced. • Water in supply tank. 	<ul style="list-style-type: none"> • Preventive maintenance. • Contaminated cartridge. • Saturated or contaminated cartridge, high duty cycle (wrong application of air dryer).

Air Dryer Cycle

The governor turns the compressor on when the supply tank pressure drops below cut-in pressure. Compressed air passes into the air dryer at the inlet port:

1. Moisture-laden air and contaminants pass through the desiccant.
2. Moisture is retained by the desiccant. Moisture also collects in the base of the dryer.
3. The governor turns the compressor off when the system reaches cutout pressure (approximately 135 psi).
4. The dryer purges and expels water collected in the dryer base.
5. When the regeneration valve opens, the dry system air flows back through the dryer. A small charge of air from the front air tank backflows through the filter. The backflow dries the desiccant, preparing it for the next cycle.

AIR SPRING INSPECTIONS

Items listed below should be checked when the motorhome is in for periodic maintenance.

NOTE:

Never attempt to service the air suspension on a motorhome with the air spring inflated.

- ◆ **Inspect** the **Outer Diameter (OD)** of the air springs. Check for irregular wear or heat cracking.
- ◆ **Inspect** air lines to ensure contact does not exist between air line and air springs. Air lines can rub a hole in an air spring very quickly.
- ◆ Ensure there is sufficient clearance around the complete circumference of the air spring while at maximum diameter.
- ◆ **Inspect** the OD of piston for buildup of foreign materials. On a reversible sleeve style air spring, the piston is the bottom component of the air spring.
- ◆ The correct ride height should be maintained. All motorhomes with air springs have a specified ride height established by the manufacturer. This height should be maintained within ¼ inch. This dimension can be checked with the motorhome loaded or empty.
- ◆ The leveling valves (or height control valves) assist in ensuring the total air spring system works as required. Clean, **inspect** and replace if necessary.
- ◆ Make sure to check shock absorbers for leaking hydraulic oil and worn or broken end connectors. If a broken shock is found, replace it immediately. The shock absorber will normally limit the rebound of an air spring and keep it from over extending.
- ◆ Check the tightness of all mounting hardware (nuts and bolts). If loose, tighten. **DO NOT** over-tighten.

Cleaning:

The approved cleaning method is to use soap and water, methyl alcohol, ethyl alcohol or isopropyl alcohol. Unapproved cleaning methods include all organic solvents, open flames, abrasive and direct pressurized steam cleaning.

HEIGHT CONTROL VALVES

Height Control Valves (HCV) inflate or deflate air springs to maintain proper suspension height throughout the load range. Two Height Control Valves are installed at the rear drive axle to control rear suspension height and left or right tilt of the motorhome. A separate HCV is installed to control front suspension height. The three HCVs mount to the main frame of the motorhome, above the axles, with a linkage rod connecting the valve to the axle.

Actuating components inside of the valves are oil dampened to reduce valve reaction to momentary suspension bounce and rebound. When a constant suspension change occurs, such as a load change or weight transfer through a sustained corner, the valve reacts by adding or purging air from the air springs as needed.

The air springs mount between the axle H-frame assembly and the two main frame rails. Air spring support plates mount to the main frame and the H-frame. There is a specified distance the air spring must maintain between the mounting plates. Other than specified distance between the plates will compromise ride quality and handling, and affect shock absorber travel, drive shaft angle, as well as various other running gear components.

BRAKE SYSTEMS

Air Brakes

The air brake system on the motorhome differs from a conventional automotive hydraulic braking system and should be treated differently. Proper maintenance and lubrication are the keys to keeping the air brake system in proper working order.

The air system supplies air to the foot brake, or treadle valve. Pushing down on the treadle valve supplies an air charge signal to a sealed brake chamber that consists of a spring and air bladder. The air charge signal pushes on the bladder and extends a threaded rod connected to the automatic slack adjuster. The slack adjuster rotates the S-cam expanding the shoes against the drum. Air disc brakes follow much the same principle, with the exception of the threaded rod directly activating calipers.

Consideration needs to be given to stopping distances and air system pressures. The motorhome requires longer stopping distances. Each brake application uses air from the air system, and engine speed is directly proportional to how fast that air system is replenished. Prepare for downhill grades. It may be necessary to select a lower gear and/or use the engine brake. Use individual short brake applications down long hills, rather than “riding” the brakes, to extend the life of the brake lining. Avoid overheating the brakes. Hot brakes have less stopping power. When maneuvering the motorhome around small areas, or backing into spaces, several individual brake applications might be made. Watch the air gauge. When preparing to back into a space swing the motorhome so it is aligned with the parking slot before backing up.

The air braking system on the motorhome is equipped with a low air pressure warning system safety feature. Should a low air condition arise while the vehicle is in operation, a warning buzzer will sound and a dash warning light will illuminate at approximately 60 to 65 psi (pounds per square inch) to alert the operator.

Park & Emergency Brake System

The Park and Emergency Brake System (Spring Brakes) applies to the rear drive axle only. When the park brake is applied, air is released from the rear brake chambers, allowing the large spring in each rear brake chamber to manually push the brake pads against the rotor. The air system must be charged above 35 psi to allow the park brake to release. Pushing down on the park brake handle charges the rear brake chambers with air pressure, overriding the emergency brake springs and releasing the brakes. In the event of air loss while the vehicle is under operation, the park brake will automatically apply (this occurs at approximately 30 psi), acting as an automatic emergency brake system.

When preparing to depart, allow the air system to achieve full air pressure as indicated by the air gauge needles. Listen for the air dryer to purge, indicating that the air dryer is functioning. Look and listen for abnormalities. Abnormal air pressure readings by either needle of the air gauge alerts the operator to have the air system checked to avoid an untimely failure.

Should a failure occur in the air system, preventing the air pressure from building, it may become necessary to “cage” the spring brakes (“*cage*” procedure in Section 2 Towing

Procedures - *Disabling Parking Brake*). This is an emergency procedure only. Caging the rear air brake chambers manually overrides the spring brakes and allows the vehicle to move. This procedure does not affect normal service braking.

NOTE:

When the park brake is released, the Park illumination lamp will remain lit until air system pressure is above 65 psi.

WARNING:

When parked with the air tank not depleted, there is possibility of an accidental release of the parking brake. Traveling with small children and/or pets may require a small block to be fabricated to prevent accidental release. The block should be placed under the knob on the dash panel. A wooden clothes pin, clasped at the base of the shaft, will work.

Brake Adjustment/Slack Adjuster

The braking system is equipped with automatic slack adjusters. As brake lining wears, the slack adjusters will automatically ratchet on the return stroke as needed. This ratchet action will keep the brake lining at proper adjustment. Brake adjustment should not be necessary. Automatic slack adjusters and the connecting S-cam shaft require periodic lubrication and inspection.

NOTE:

Replacement parts should be of the same original equipment size and type. Mixing brake components may result in unequal braking action. Brake maintenance is not covered by the manufacturer.

WARNING:

Brake lining may contain asbestos material and should only be serviced by qualified service technicians who are trained in the appropriate precautionary procedures. If any loss of braking effectiveness or abnormal braking indications are noticed, the brakes and slack adjusters should be inspected by a qualified brake technician.

Brake Systems - Backup

The motorhome air braking system is equipped with backup safety systems and warning alarms in the event of air system failure. For example: should the air compressor fail to charge the air system and low air gauge readings go undetected, a low air pressure warning buzzer will sound and a low air pressure dash warning indicator light will flash. These warning indicators occur at approximately 65 psi. This will alert the operator of an impending situation. If the motorhome is allowed continued operation, the pneumatic emergency spring brake relay valve, installed in the air system, senses the low air pressure condition and will release the air charge from the spring brake air chambers on the rear drive axle. In this case, the park brakes will automatically apply at approximately 30 psi. This safety backup system acts as an automatic emergency brake system.

Another backup safety is the air system separation of the front and rear brakes, implemented by using two air tanks. One tank is located in the front and the other is located in the rear. This separation allows the front air tank to operate the front brakes; the rear tank operates the rear drive axle brakes and tag axle

brakes. This tank division gives reassurance in case one tank experiences a failure of an accessory air item allowing the compressed air to escape.

Accessory air items are other pneumatically operated items such as the air horn, vacuum generator, etc. The accessory air items operate only when air tank pressures exceed 65 psi. This is done with pressure protection valves. Should an accessory air item fail, the pressure protection valve (PPV) reserves the remaining air pressure of 65 psi for braking. This will leave the motorhome with one air tank fully charged for safety backup.

The rear air tank also has a safety backup - the safety inversion valve. The inversion valve senses the absence of rear air tank pressure. In this case the inversion valve will allow the operator to make a modulated spring brake application, made in conjunction with the emergency spring brake relay valve. The inversion valve allows the front air tank pressure to recharge the rear brake chambers after the modulated spring brake application has been made. This backup system implements use of all the brakes, allowing the operator to bring the motorhome a safe stop. In case of all compressed air charge escaping from the front air tank, the operator will still have full use of the rear brakes.

ABS/ATC SYSTEM (ANTI-LOCK BRAKES)

The motorhome is equipped with an anti-lock braking system (ABS) and automatic traction control system (ATC). The ABS system monitors wheel rotation speeds by using a 100-tooth magnetic tone ring mounted to the hub.

Revolving with the wheel, the magnetic tone ring is polarized giving positive and negative pulsations. A stationary sensor is mounted adjacent to the tone ring to monitor magnetic pulses. The pulses are monitored by the ABS electronic control unit (ECU).

The ECU monitors all wheel sensors at the rate of 100 times per second. The ECU controls Pressure Modulator Valves. Pressure Modulator Valves have two electric-over-air solenoids, a hold solenoid and a release solenoid. The modulator valves are open under normal braking, allowing a straight through air signal from the treadle valve to the brake chamber. Should a wheel lose traction under a braking application, the ECU will energize the hold solenoid of the Pressure Modulator Valve to interrupt the air signal from the treadle valve to the brake chamber. The release solenoid vents the existing air signal, at the brake chamber to the atmosphere, allowing the skidding tire to regain traction. Skidding tires have less traction. It is possible, under certain conditions, to have the wheel(s) skid with a normal functioning ABS system.

The ABS itself does not apply additional braking power. The purpose of the ABS is to limit wheel lock and decrease stopping distance. Cautious driving practices and maintaining adequate safe distance when following vehicles is the key to safe vehicle operation.

WARNING:

The ABS/ATC system is designed to increase tire to road surface traction but cannot overcome naturally occurring laws of physics. The ABS/ATC system, combined with safe driving practices, will reduce the possibility of wheel skid and loss of lateral stability.

ABS Component Function:

- ◆ Speed sensors and tone rings on each wheel monitor wheel rotation.
- ◆ Each speed sensor communicates wheel rotation pulses to the Electronic Control Unit.
- ◆ The ECU receives the speed sensor signal pulses to calculate speed and acceleration rates of each wheel.
- ◆ Based on the speed sensor input, the ECU detects impending wheel lock and operates the ABS Modulator Valves required for proper control. The Modulator Valves are operated in the Air, Release or Hold modes to regulate air pressure to the brake chambers.
- ◆ Braking force is applied at a level which minimizes the stopping distance while maintaining as much lateral stability as possible.

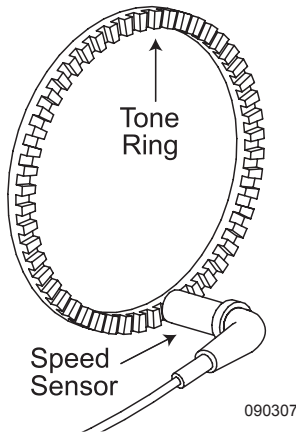

- ◆ When the ignition is turned on, the ABS indicator illuminates momentarily (3 seconds) verifying the self-diagnostic test. If the ABS indicator light remains on, or illuminates while the motorhome is being operated, this indicates a fault in the anti-lock brake system. This fault will not affect normal service braking. The motorhome will need to go to a service center to repair the problem.

INFORMATION:

If a fault code occurs, call a Bendix service locator at 1-800-247-2725 and take the motorhome to the nearest repair facility.

ABS Diagnostic Button:

By properly actuating the ABS diagnostic button, system configuration codes and fault codes can be retrieved as flashed sequences on the ABS warning light. System configuration codes are sequences of six flashed digits while fault codes are sequences of two flashed digits. Refer to an authorized Bendix service center for a list of code sequences. If the Diagnostic button is not pressed correctly for a specific readout, stop and start over at the beginning of the procedure.

NOTE:

All codes are displayed by the ABS warning light only.

The flash code switch is capable of performing several diagnostic mode functions. After ignition, a two second delay must be observed prior to pressing the diagnostic button. For functions requiring multiple presses the delay between presses cannot be longer than two seconds.

Active code retrieval is 1 press.

Inactive code retrieval is 2 presses.

Clearing active codes is 3 presses.

System configuration check is 4 presses.

Dynamometer test mode is 5 presses.

Reconfigure ECU is 7 presses.

NOTE:

Reconfigure Mode is entered by holding the switch in prior to “ignition on.”

Once ignition is on, release the switch, then press 7 times.

ATC System:

The ATC system improves traction on slippery or unstable road surfaces by limiting excessive drive wheel slip. This is accomplished two ways, limiting engine torque to the drive wheel or engaging a brake to the spinning drive wheel. During normal operation engine torque is unaffected. The ATC system works in conjunction with the ABS Electronic Control Unit. The ECU monitors tone ring speed of the drive wheel in relation to the other wheels. If a speed differential occurs in the drive wheel, the ECU enters Automatic Traction Control mode.

ABS Warning Light:

The ABS will perform a dash indicator lamp check and self-diagnostic test each time the ignition is switched to the on position.

During an ATC event, the ECU will automatically react to optimize traction and safety if the motorhome encounters a slippery road surface. Engine torque is normally reduced to limit drive wheel slip.

NOTE:

The ATC system is always active.

ATC reacts to drive wheel slip by:

- ◆ Reducing engine torque to the drive wheel if road speed is above 25 mph.
- ◆ Reducing engine torque and activating drive axle brake controls if road speed is below 25 mph. If the brake control activates, it remains active regardless of road speed.

How Automatic Traction Control (ATC) Works

If this wheel is spinning due to slippery surface or wheel off the ground, the ABS system with ATC applies the brake to this wheel.

This wheel then delivers torque to the ground.

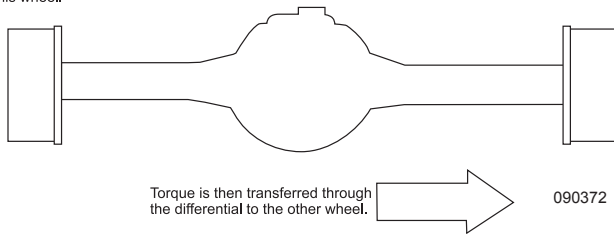

ATC Switch:

Activating the ATC switch reduces ECU control over engine torque. Momentarily pressing the ATC switch allows the ECU to increase the amount of engine torque applied to the drive wheel in an ATC event. The amount of engine torque applied to the drive wheel will vary with the amount of drive wheel slip versus road speed. In an ATC event, the ECU remains active regardless of road speed or switch position. The light flashes slowly when the ATC switch is activated.

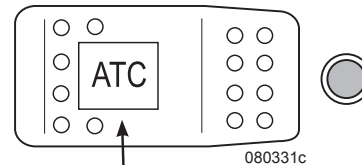

Located on driver's console.

ATC Indicator Light:

During normal operation, the ATC indicator light on the dash will illuminate steady when the ignition key is turned **ON**. If an ATC event occurs, the indicator light will flash quickly. The indicator light will flash slowly if the ATC switch is activated.

CAUTION:

Normally the switch should remain inactive. During an ATC event (drive wheel slip) the ECU will automatically optimize drive wheel traction in most situations. Activating the switch during periods of wheel slip can increase torque to the spinning drive wheel. Drive train damage can occur if the spinning drive wheel should suddenly regain traction. If the motorhome is stuck it is advised to call a professional towing company to limit the possibility of body and drive train damage.

FRONT AXLE

While driving the motorhome, be aware of any changes in the feel of steering and have the system checked when noting apparent differences. It is normal to hear some hydraulic noise from the steering, especially when the steering is at maximum, or while turning the wheel when the motorhome is parked. Investigate any unusual or loud noises that occur. Begin by checking the level of the hydraulic fluid. Traveling at slow speeds over rough surfaces may cause a “clunking” noise to emanate from the steering column, but if noise is heard on smooth surfaces while sharply turning back and forth, the noise should be inspected and repaired as necessary.

Shimmy and looseness should be checked and corrected as soon as possible. If looseness is felt in the steering, the steering linkages can be observed while someone turns the steering wheel left and right. Watch the linkages for evident play or uneven interaction between components to help pinpoint a problem. Wheel bearings should be cleaned and repacked with high temperature disc brake grease every 30,000 miles. Have the steering system checked for damage after a severe impact, such as striking large potholes or curbs, and front-end collisions. Observe the alignment of the steering wheel; a change in the alignment may indicate damage to the steering components or suspension.

Maintenance for the system entails adequate lubrication. Use only a hand operated grease gun on the fittings. Grease fittings for the steering system are found on the both ends of the drag link (the bar connecting the steering gear to the axle), and on the intermediate steering shaft located between the steering wheel and steering gear. The correct wheel alignment promotes longer tire wear and ease of handling while minimizing the strain on the steering system and the axle components. Use NLGI #2 Lithium soap base lubricant for all steering linkage and brake components.

Alignment

Camber:

Camber, as shown, is vertical tilt of wheel as viewed from the front of the motorhome. This is machined into the axle when manufactured and is not adjustable.

- **“Positive”** camber is an outward tilt of the wheel at the top.
- **“Negative”** camber is an inward tilt of the wheel at the top.

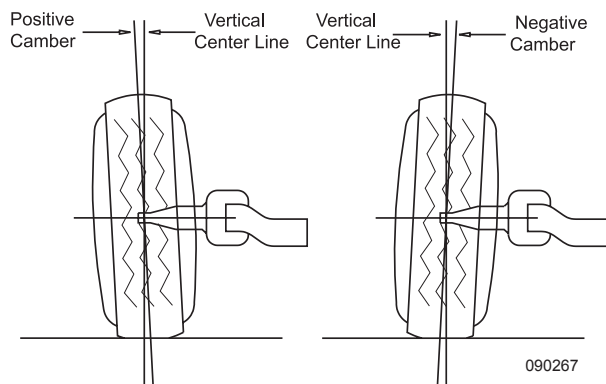

Toe Setting:

The toe setting represents different distances between the front and rear of the tires (measured at the vertical center line of the tires).

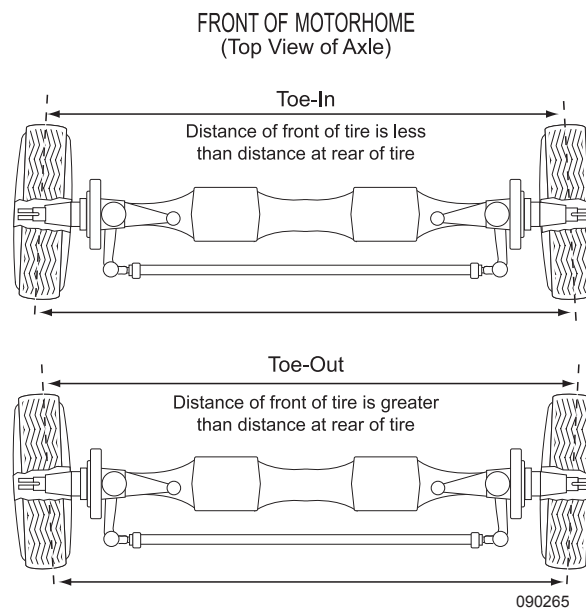

Toe-in: Occurs when the tire front distance is less than the tire rear distance.

Toe-out: Occurs when the tire front distance is greater than the tire rear distance.

Wheels are generally set with initial toe-in. As the motorhome operates tires tend toward a toe-out condition. By starting with an initial toe-in setting, a desirable “near zero toe-in” can be achieved when the motorhome is in motion.

Incorrect toe settings, where toed-in or toed-out, can have a significant affect on tire wear.

The toe setting is adjusted by lengthening or shortening the cross tube.

Caster Adjustments:

Caster is the fore and aft tilt (toward the front or rear of the motorhome) of the steering kingpin as viewed from the side of the motorhome.

“Positive” caster is the tilt of the top end of the kingpin toward the rear of the motorhome.

“Negative” caster is the tilt of the top end of the kingpin toward the front of the motorhome.

Setting the caster angle more positive than specified may result in excess steering effort and/or shimmy. Decreasing the angle may result in the motorhome wandering or poor steering return to center. The caster angle is determined by the installed position of the steer axle.

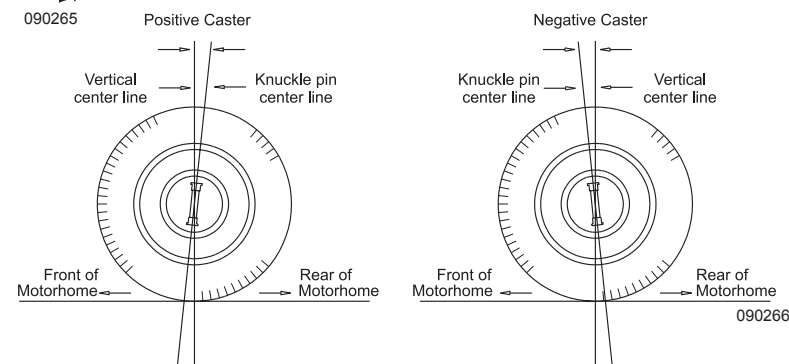

	Left	Right
Camber	1/8 ° +/- 7/16 °	-1/8 ° +/- 7/16 °
Caster*	5 ° +/- 1 °	7 ° +/- 1 °
Total Toe	1/16" (0.08 °)	

* Right must exceed Left at least 1.5 °, but less than 2.5 °.
NOTE: Motorhome must be at ride height for proper alignment.

Lubrication Maintenance Safety

The front axle components require periodic lubrication maintenance. Chock wheels for safety prior to accessing components underneath the motorhome.

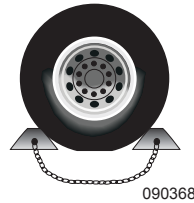

WARNING:

Never place yourself under motorhome without first properly blocking frame (jackstands) from coming down in case of rapid deflation of air system.

NOTE:

Suspension and steering components are lubricated at factory using Texaco Starplex NLGI 2 Lithium Soap based grease.

1. Axle Beam
2. Steering Box
3. Intermediate Steering Shaft
4. Universal Joints
5. Slip Yoke
6. Ball Joint
7. Steering Column
8. Steering Wheel
9. Right Knuckle Assembly
10. Spindle
11. Kingpin
12. Centerlink
13. Pitman Arm
14. Drag Link

Greasing the Intermediate Steering Shaft Universal Joints:

1. Check the shaft for looseness. Repair if loose or worn.
2. Apply the specified grease at the grease fitting on the universal joint. Apply until the new grease purges from all the seals.
3. If the new grease does not purge from the seals, disassemble and clean the joint or replace the universal joint. **DO NOT** lose the needle bearings.

Steering Components

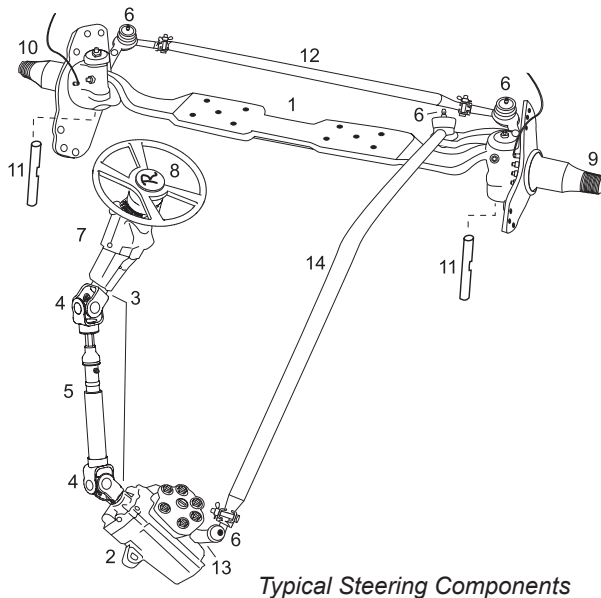

Typical Steering Components

Steering Column

The intermediate steering shaft connects the steering wheel to the steering box. Service the intermediate steering shaft universal joints and slip yoke every 30,000 miles or annually. Remove the steering column cover to access the upper universal joint and slip yoke lubrication points. The lower universal joint is accessed from underneath in the generator compartment behind the front electrical box.

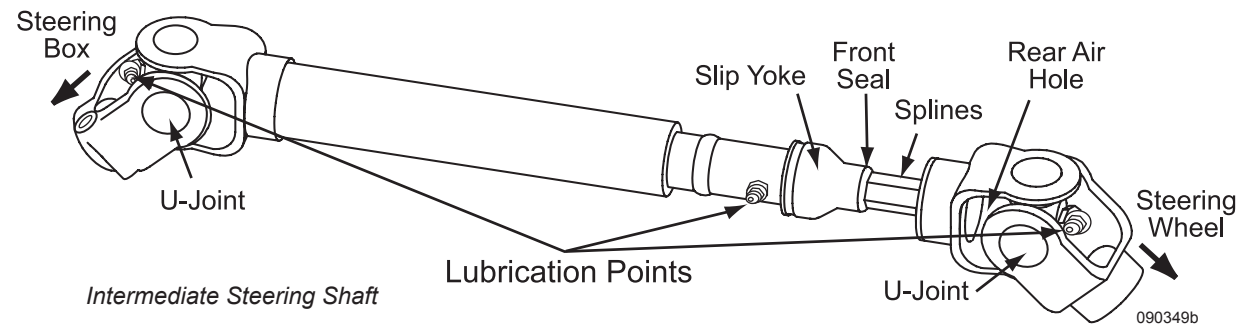

Greasing the Intermediate Steering Shaft Slip Yoke and Splines:

1. Check the shaft for looseness. Repair if loose or worn.
2. With finger, cover the rear air hole so grease flows to the front seal. Apply the specified grease at the grease fitting on the slip yoke. Apply until new grease purges and forces finger away from the air hole in the end of the slip yoke. Greasing interval is yearly or every 30,000 miles.

NOTE:

Depending upon application universal joints may have two grease fittings each. It is necessary to apply grease to each fitting to properly lube the universal joint.

Drag Link

The drag link connects the steering box pitman arm to the steer axle. The movable joint (ball joint) uses sealed boots to prevent water intrusion. **DO NOT** rupture the boot when applying grease. Grease interval is six months or every 5,000 miles.

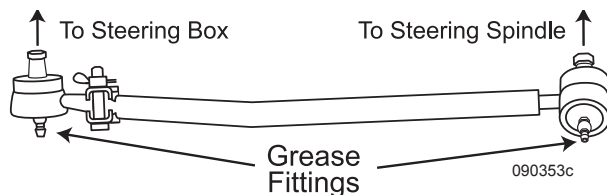

NOTE:

It will be necessary to start the motorhome and turn the steering wheel to access fitting(s).

Center Link

The center link is located on the backside of the steer axle. The center link attaches the two wheels together causing the right front to track with the left front. Greasing interval is every six months or 5,000 miles.

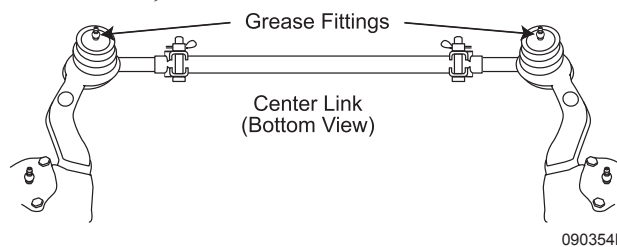

Steering Spindles

The steering spindles attach to the front axle and pivot on the kingpin. The wheel end assembly and brake system attach to the spindle. There are upper and lower lubrication points for the kingpin. The drag link attaches to the roadside spindle. After initially lubricating the roadside and curbside kingpins, rotate the steering assembly lock to lock (full left to right) then move assembly back to center. This purges any remaining air pockets. Continue lubricating the kingpins until new grease purges with no air pockets. Greasing interval is every six months or 5,000 miles.

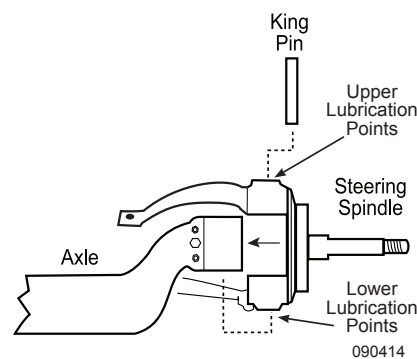

Control Arm Bushings

Control arms align the axles perpendicular with the frame. The panhard bar controls side to side motion of the axles in the frame. Control arm bushings and panhard bar bushings do not require lubrication.

STEERING GEAR

Maintain the grease pack behind the output shaft's dirt and water seal as a general maintenance procedure at least twice a year. The grease fitting is provided in the housing trunnion. Use NLGI grade 2 multipurpose chassis lube and use only a hand operated grease gun on the fitting. Add grease until it begins to extrude past the sector shaft dirt and water seal.

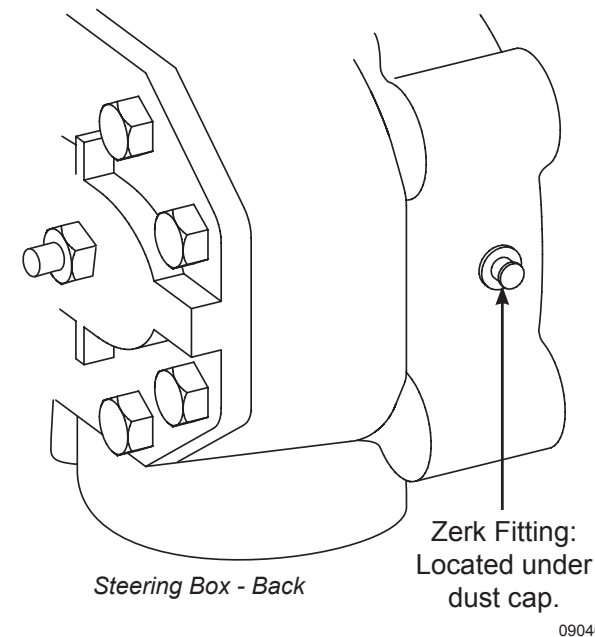

Power steering is provided by using hydraulic pressure to assist rotating the output shaft of the steering gear. Located at the end of the input shaft of the steering gear is poppet valve and worm drive. The poppet valve directs the hydraulic fluid pressure to a type of spool. The worm drive threads in the center of the spool. When in the center position, pressurized hydraulic fluid bypasses the spool. When a turn is made, the poppet valve shifts to one direction or the other, directing the hydraulic pressure to one side of the spool depending on turning direction. The hydraulic fluid is then cooled before returning to the reservoir.

NOTE:

Inspect for signs of leakage when performing fluid level checks.

Changing the hydraulic filter in the engine compartment at regular intervals will help ensure trouble-free operation.

DRIVE AXLE & DRIVE SHAFT

Drive Axle:

The chassis drive axle is a single reduction axle. The differential gears consist of a hypoid pinion and ring gear set and bevel differential gears. The differential carrier can be removed from the axle housing as a unit in order to perform repairs.

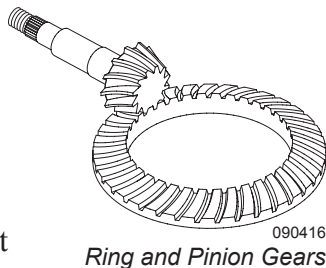

All power from the engine to the rear tires is transferred through the rear axle. For this reason, it is important that maintenance be performed on the axle as required to avoid premature wear of the gears and bearings in the axle.

Drive Axle Lubricant:

The rear axle is filled with 80w-90 gear oil meeting SAE J 2360 specifications. Change interval is every 250,000 miles or 36 months, whichever occurs first.

During lubricant change, fine metal particles will be observed clinging to the magnetic fill and drain plugs of the axle. These particles are normal wear particles from the axle components, but will cause faster than normal wear of the axle components if allowed to circulate through the lubricant. It is recommended that the magnetic plugs be tested, if not replaced, at each lubricant change. These plugs should have sufficient magnetic strength to pick up a 1.5 pound weight of low carbon steel. Never replace a magnetic plug with a non-magnetic “pipe plug” as they will not keep the lubricant clear of metal particles or seal properly.

The level of lubricant in the rear axle should be checked every 30,000 miles or annually, whichever occurs first. This will ensure adequate lubricant in the axle for proper operation. Regular inspection of the drive axle lube levels is an essential maintenance procedure.

WARNING:

Never place yourself under motorhome without first properly blocking frame (jackstands) from coming down in case of rapid deflation of air system.

Proper Drive Axle Lubricant Level:

- ◆ With the motorhome parked on a level surface and rear axle warm, place a large container under axle.
- ◆ Clean the area around the fill plug, which is located approximately halfway up the axle housing bowl.
- ◆ Remove the fill plug and observe the lubricant level.
- ◆ The lubricant should be level with bottom of the hole.
- ◆ Important: The lube level close enough to the hole to be seen or touched is not sufficient. The lube must be level with the hole.
- ◆ Correct the level as necessary.
- ◆ Re-install the fill plug and tighten to 35 to 50 ft. lbs.

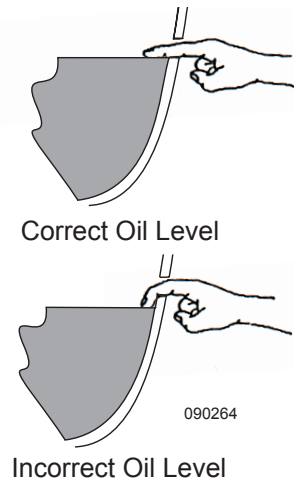

To Drain and Replace Lubricant:

1. Place a large container under the axle.
2. Remove drain plug and allow axle to completely drain.
3. Properly dispose of oil.
4. Clean the drain plug and test (replace the drain plug if needed).
5. Install and tighten drain plug to 35 to 50 ft. lbs.
6. Clean the area around the fill plug from the axle-housing bowl.

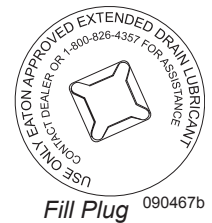

- Fill the axle with approved lubricant until the level is even with the bottom of the fill plug hole.

WARNING:

When checking or changing the lubricant, always ensure that the axle is not hot. Oil temperature 90° F or hotter can easily cause severe burns.

NOTE:

When checking the lube level also check the housing breathers on top of axle housing. Clean the breathers if dirty or replace them if damaged.

Drive Shaft:

The drive shaft transfers the power produced by the engine to the drive axle. A worn or out of balance drive shaft causes chassis vibration that generally increases in intensity with road speed.

Lubrication Maintenance:

The drive shaft requires periodic lubrication maintenance. Lubricate the slip joint and universal joints every 5,000 miles or 6 months, whichever occurs first. Use NLGI #2 chassis lubricant.

NOTE:

It will be necessary to move the motorhome forward or backward to access all fittings on the drive shaft.

Greasing the Drive Shaft Universal Joints:

- Check the drive shaft for looseness. Repair if loose or worn.

- Apply the specified grease at the grease fitting on the universal joint. Apply until new grease purges from all the seals.
- If new grease does not purge at the seals, loosen the bearing cap bolts and re-grease until all four caps purge. If new grease still does not purge, disassemble and clean or replace the universal joint.

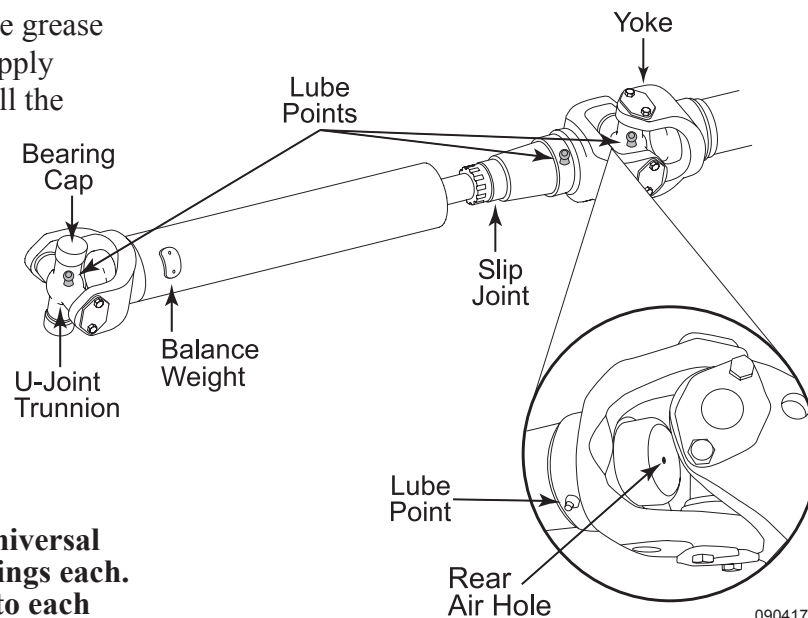

090417b

NOTE:

Depending upon application universal joints may have two grease fittings each. It is necessary to apply grease to each fitting to properly lube the universal joint.

Greasing the Drive Shaft Slip Yoke and Splines:

- Check the drive shaft for looseness. Repair if loose or worn.
- With finger, cover the rear air hole so grease flows to the front seal. Apply the specified grease at the grease fitting on the slip yoke. Apply until new grease purges and forces finger away from the air hole in the end of the slip yoke.

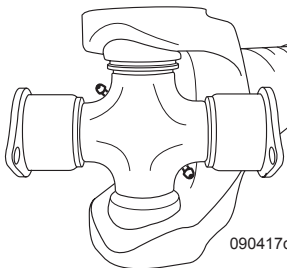

090417d

Dual Zerk U-Joint

WARNING:

Rotating shafts can be dangerous. Rotating shafts can snag clothes, skin, hair, hands, etc. causing serious injury or death. DO NOT work on or near a shaft with or without a guard when the engine is running.



090341

TAG AXLE

Raising or lowering the tag axle is integrated into the Air leveling pad and optional Air/Hydraulic leveling pad located on the roadside cockpit panel. Pushing the pad marked **TAG LIFT** will illuminate the corresponding LED. When using the **TAG LIFT** feature the tag axle will not raise until the engine has been running for two minutes. Traveling with the tag axle raised will initiate an audible warning. The tag axle will automatically lower when the motorhome exceeds 10 mph. When equipped with Optional Hydraulic leveling only, a stand alone switch is used to raise or lower the tag axle. The switch for the tag axle is located on the roadside cockpit switch panel. Two lights are located on the switch: The tag axle icon will illuminate with the park lights. The lower bar light will illuminate when the tag axle switch is on and the transmission is in neutral, reverse or first gear. When the transmission is in second through sixth gear, the tag axle is automatically lowered and the light will be off. A beeping alarm sounds when the switch is on. Raise the tag axle when performing tight maneuvers under 5 mph to reduce turn radius and prevent the tag axle tires from scuffing.

NOTE:

With the tag axle in the up position, there is not a specific height requirement other than the tire should be off the ground.

Adjusting the tag axle load:

Changing the amount of weight carried by the tag axle affects weight distribution between

the tag, drive and steering axles. The amount of down force applied to the tag axle is controlled by the amount of air pressure in the tag axle air bags. An adjustable pressure regulator located in the engine compartment sets the amount of air pressure in the tag axle air bags. Regulator pressure is preset at the factory and may require adjustment to obtain the proper weight distribution on all axles. To determine the correct setting of the pressure regulator, weigh the motorhome after it has been loaded for travel.

NOTE:

The tag axle pressure regulator valve is located in the engine compartment on the roadside.

Tag Axle Lubrication:

All tag axles use oil to lubricate the wheel bearings. The oil is drained and refilled without removing the wheel end assembly. Remove the hubcap to access the bearing cover and drain plug.

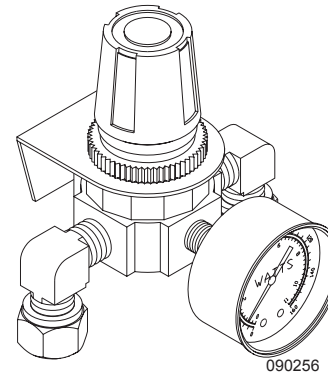

090256
Tag Axle Pressure Regulator located roadside in engine compartment.

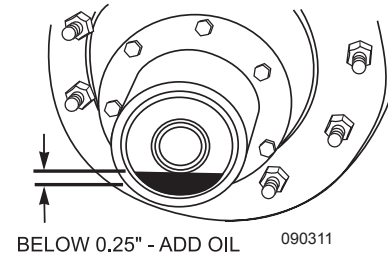

To inspect the oil level:

- ◆ The motorhome must remain stationary for 30 minutes.
- ◆ Remove the chrome hubcap.
- ◆ Locate the full and add mark on the outside of the clear plastic cover.
- ◆ If the lubricant is low, add recommended fluid to proper level.

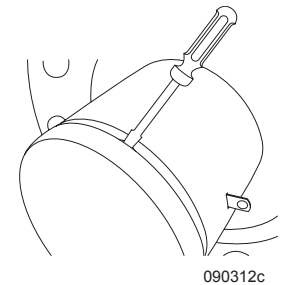

090312c

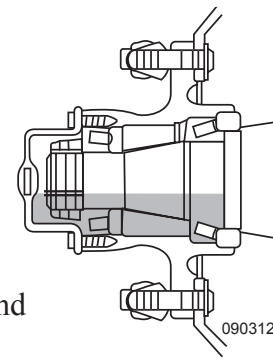

090312b
Shading Indicates Correct Amount of Oil

Oil Change Intervals

The recommended oil change interval is based on operating conditions, speeds and loads. Limited service applications may allow the recommended interval to be increased. Severe applications may require the recommended interval to be reduced. For more information, contact a Dana/Eaton service representative.

Recommended Interval Change:

- ◆ Change the fluid whenever the seals are replaced, the brakes are relined or at 30,000 miles (48,000 km). However, check the lubricant twice a year (spring and fall) for contamination. Change as needed.
- ◆ If yearly mileage is less than 30,000 miles, change the fluid twice a year (spring and fall).

Lubricant Type:

- ◆ Texaco Star Gear Lubricant SAE 80w/90. Specifications, minimum ambient temperature - 15° F (-26.1° C). There is no maximum ambient temperature. Lubricant temperature must never exceed 250° F (+121° C).

To Drain:

- ◆ Place a suitable container below the bearing cover and remove the drain plug. If the cover does not have a drain plug, remove the screws retaining the cover plate to drain the lubricant.
- ◆ Replace plug or cover plate and fill bearing assembly with the recommended lubricant.

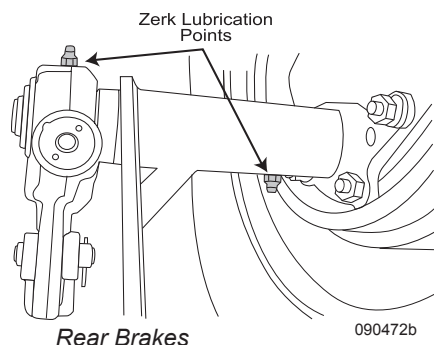
DRUM BRAKE LUBRICATION

The drive and tag axle slack adjuster and “S” cam shaft need to be periodically lubed to ensure proper brake operation. Lubricate every 10,000 miles or 3 months.

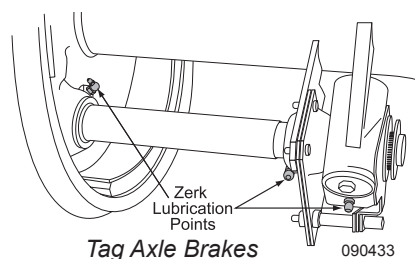
**SHOCK ABSORBER**

The shock absorber is a hydraulic device used to dampen suspension/ body movement. Road surface irregularities are compensated for by the shock absorber. The Roadmaster chassis incorporates the Bilstein shock in the design of the exclusive air glide suspension system. This shock absorber is a telescopic, mono tube unit filled with nitrogen gas and hydraulic oil. The result of the mixture is uninterrupted damping for the smallest of wheel deflection.

By design, a self lubricating seal is used which will allow approximately 10% of the total oil capacity to pass onto the piston rod. The gradual process of oil loss does not affect the performance of the shock absorber during the service life. This process will be evident after a long period of service by an oil film on the body of the shock absorber. The appearance of a coating or film on the body or rod is completely normal, it is an indication the shock is functioning normally.

Road holding, handling, balance and braking

characteristics all can be contributed to the shock absorber. The operating conditions for which the shock absorber must endure will determine the life span. However, since the only moving part is the piston rod, there are no springs, hinges or pins to wear out, get weak or deteriorate.

AIR LEVELING

Located on the roadside drivers console is the air leveling control touchpad. The computer controlled system can operate automatically or manually to adjust the air springs when leveling the motorhome.

NOTE:

The motorhome engine must be ON for the air suspension to operate.

NOTE:

The automatic leveling system will perform best if there is no movement in the motorhome while the system is attempting to level.

CAUTION:

Several inches of unobstructed downward travel is required when using the leveling system. Look underneath the motorhome for any obstacles that could damage the undercarriage components before using the leveling system. set.

WARNING:

Never engage the leveling system when anybody is near or underneath the motorhome. Serious injury or death can occur.



Automatic Air Leveling

Prior to leveling:

- ◆ Set park brake.
- ◆ Place transmission in neutral.
- ◆ Ensure front wheels are pointing straight ahead.
- ◆ Have motorhome at ride height with air tanks full.
- ◆ Turn off ignition and extend slide-outs.

Leveling Procedure:

- ◆ Start engine.
- ◆ Press the **POWER** button on the leveling control panel to turn the system **ON**. The Power indicator light will glow solid green.

- ◆ Press the **AUTO** button to initiate the leveling process. The indicator light above Auto will blink and the motorhome will automatically level itself. Red lights in the motorhome icon indicate the motorhome is leveling. The system measures along 3 different axes (rear axle, front axle and longitudinal axis) of the chassis to check for both level and flex in the motorhome.
- ◆ Wait until all lights in the motorhome icon turn solid green. The motorhome is level.
- ◆ When leveling is achieved, leave the control panel on and turn ignition switch off.

After leveling:

- ◆ After 15 seconds, the leveling system goes into “Sleep” mode. This will minimize parasitic current draw on the chassis batteries.
- ◆ After 20 seconds, the system goes into “Low Power” mode indicated by the occasional flashing of the Auto and Power indicator lights.
- ◆ After a period of time in “Low Power” mode the system automatically “wakes” and checks to see if re-leveling is required.
- ◆ If leveling is required the system will automatically level the motorhome.

NOTE:

Turning off the control panel after leveling will disable the system and not allow automatic re-leveling if necessary.

System Air Compressor:

Should air pressure in the leveling system need adjustment while in Automatic Leveling mode, a small air compressor provides the leveling system with air pressure. This compressor requires no maintenance.

Manual Air Leveling

The Manual Leveling Mode gives the operator control over the leveling process.

NOTE:

Manual control of the air system can be used while traveling at low speed when an uneven surface must be negotiated.

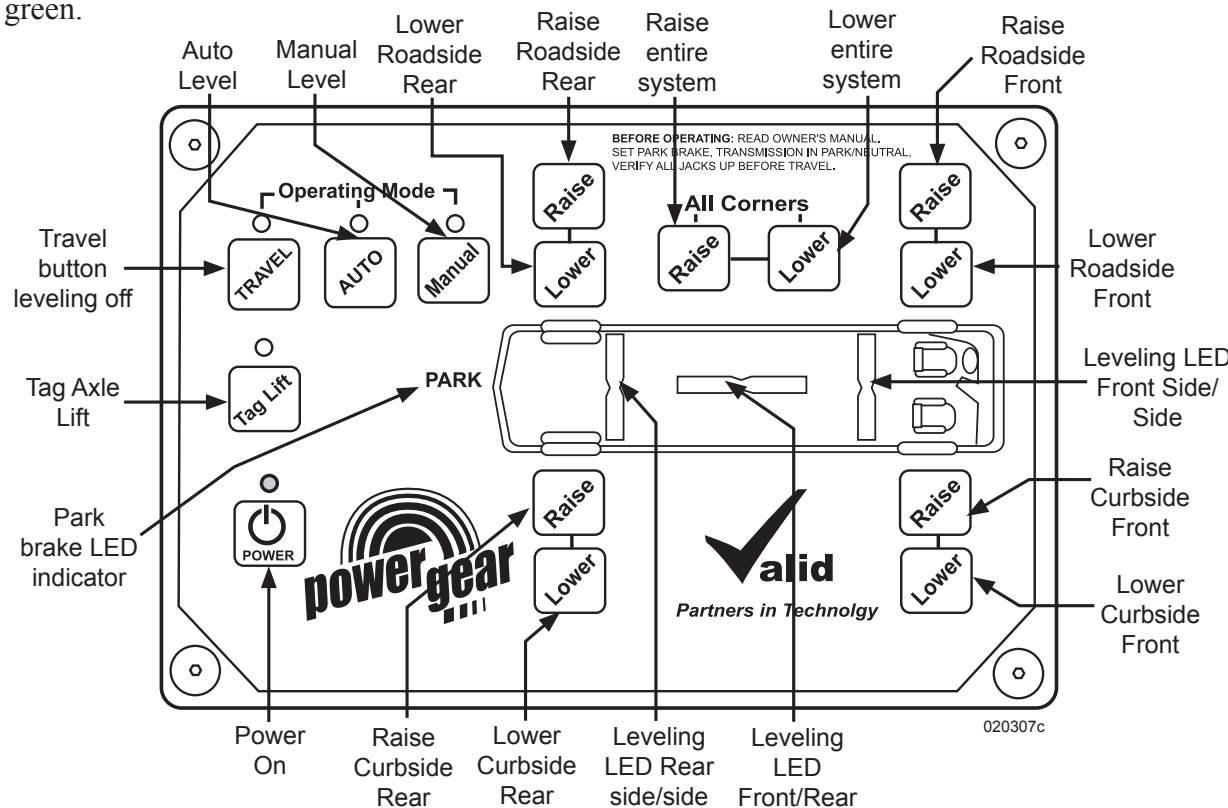

Prior to leveling:

- ◆ Set park brake.
- ◆ Place transmission in neutral.
- ◆ Ensure front wheels are pointing straight ahead.
- ◆ Have motorhome at ride height with air tanks full.
- ◆ Turn off ignition and extend slide-outs.

Leveling Procedure:

- ◆ Start Engine.
- ◆ Press the **POWER** button on the leveling control panel to turn the system on. The Power indicator light will glow solid green.
- ◆ Press the **MANUAL** Mode button. The indicator light above Manual will blink.
- ◆ Press **RAISE** or **LOWER** for each of the four corners to be manually adjusted. During the leveling process a red light will blink on the motorhome icon. Once that corner is level the light will turn solid green. Proceed to the next corner until the motorhome is level.
- ◆ To control all 4 corners simultaneously use the **ALL CORNERS RAISE** and **ALL CORNERS LOWER** buttons.
- ◆ When leveling is achieved turn ignition switch off.

Travel Mode

Travel Mode is the operational mode used when the motorhome is in motion. This mode gives control of the motorhome air suspension system to the ride height valves.

WARNING:

The time required to achieve travel height varies. Make sure that the motorhome is at ride height before driving. If the motorhome is too low, severe damage can result.

To Use Travel Mode:

- ◆ Start engine and press the **TRAVEL** button.
- ◆ If the Air Leveling System is turned off or in any other mode other than Travel, it automatically turns on and switches to Travel Mode when the motorhome speed exceeds its designated Travel Mode speed limit (set in the initial configuration of the system).
- ◆ Enter Travel Mode before the motorhome begins moving.

NOTE:

When using the TAG LIFT feature the tag axle will not raise until the engine has been running for two minutes. Traveling with the tag axle raised will initiate an audible warning. See TAG AXLE for detailed information concerning operation.

INFORMATION:

For detailed information and operating instructions on the Air Leveling System, refer to the manufacturer's manual.

LEVELING - AIR /HYDRAULIC (OPTIONAL)

Located on the roadside drivers console is the air hydraulic leveling control touchpad. The computer controlled system can operate automatically or manually to adjust the hydraulic jacks when leveling the motorhome.

CAUTION:

The leveling jacks are not designed for changing tires. This can cause problems with the suspension system, frame alignment and damage to the windshields. Never use the jacks to elevate any wheel position off the ground.

Hydraulic Automatic Leveling**Prior to leveling:**

- ◆ Set park brake.
- ◆ Place transmission in neutral.
- ◆ Ensure front wheels are pointing straight ahead.
- ◆ Have motorhome at ride height with air tanks full.
- ◆ Turn off ignition and extend slide-outs.

CAUTION:

Hot asphalt, gravel or dirt may not support the weight that is placed on the hydraulic jack pads. Place thick plywood under the jack pads to help disperse the weight. If blocking up a rear jack pad to gain added clearance when the motorhome is on a slope, place a wheel chock at the opposite set of rear wheels to prevent the motorhome from rolling.

CAUTION:

Survey the area around and under the motorhome for obstructions that can damage the motorhome or undercarriage components before lowering the air suspension. Damage to mud flap may occur if it is located over a raised area.

CAUTION:

Ensure the potential jack contact points are clear of obstructions or depressions before operation. Keep all people clear of the motorhome during the leveling system operations. Never expose hands or other parts of the body near hydraulic leaks. Hydraulic lines are under high pressure. Oil leaks may cut and penetrate the skin causing serious injury.

NOTE:

If additional height or surface support is needed, construct a 1' x 1' wooden block made from two pieces of $\frac{3}{4}$ " plywood for a total thickness of $1\frac{1}{2}$ ". Drill hole in corner and use awning wand to slide wooden block under jack pad.

Leveling Procedure:

- ◆ Start engine.
- ◆ Press the **POWER** button on the leveling control panel to turn the system on. The Power indicator light will glow solid green.
- ◆ Press and release **HYD**. The indicator light above will blink.
- ◆ Press and release **AUTO**. The indicator light above AUTO will blink.

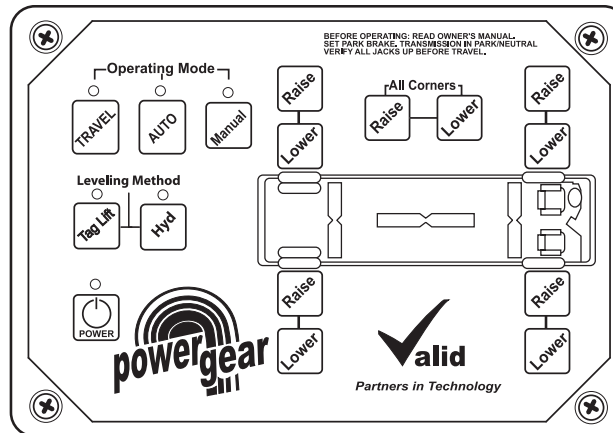

- ◆ During the leveling cycle the Power indicator light remains on and the Auto indicator light flashes until the motorhome reaches a level state. During this cycle the air bags will deflate as the motorhome lowers. The leveling system measures along 3 different axles (rear axle, front axle and longitudinal axis) to check for both level and flex in the motorhome. Both rear jacks lower (one at a time) prior to the front jack lowering.
- ◆ Rear jacks lower one at a time prior to the front jacks lowering.
- ◆ Wait until all lights in the motorhome icon turn solid green. The Auto indicator light will stop flashing and stay lit. The motorhome is level.
- ◆ When leveling is achieved, leave the control panel on and turn ignition switch off.

CAUTION:

DO NOT move the motorhome while the jacks are still in contact with the ground or extended. Damage to the jacks can occur.

Once The Motorhome Is Level:

- ◆ After 15 seconds the leveling system goes into “Sleep” mode. This will minimize parasitic current draw on the chassis batteries.
- ◆ After 20 seconds the system goes into “Low Power” mode indicated by the occasional flashing of the Auto and Power indicator lights.

NOTE:

Turning off the control panel after leveling will disable the system and not allow automatic re-leveling if necessary.

INSPECTION:

Before moving the motorhome always perform a visual inspection to be sure that all jacks have fully retracted. Remove any debris that may be on the jack pad.

Hydraulic Manual Leveling

- ◆ Set park brake.
- ◆ Place transmission in neutral.
- ◆ Ensure front wheels are pointing straight ahead.
- ◆ Have motorhome at ride height with air tanks full.
- ◆ Turn off ignition and extend slide-outs.

Leveling Procedure:

- Start engine.
- ◆ Press the **POWER** button on the leveling control panel to turn the system on. The Power indicator light will glow solid green.
- ◆ Press and release **HYD**. The indicator light above HYD will blink.

- ◆ Press and release **MANUAL**. The indicator light above Manual will blink.
- ◆ Press the individual **RAISE** or **LOWER** buttons to raise or lower the motorhome at any jack position. The **ALL CORNERS RAISE** and **ALL CORNERS LOWER** buttons may also be used.
- ◆ Turn ignition switch off when motorhome is level.

Emergency Retract:

- ◆ In the event the motorhome is placed into gear, or the parking brake is released, an audible warning will sound, air bags will return to ride height and jacks will retract.

NOTE:

The hydraulic controls do not work in Travel Mode.

Air leveling:

Follow guidelines stated under Automatic Air Leveling Procedure or Manual Air Leveling Procedure.

INFORMATION:

For detailed information and operating instructions on the Hydraulic/Air Leveling System refer to the manufacturer's manual.

LEVELING - HYDRAULIC (OPTIONAL)

The leveling system is designed to reduce sight selection problems and stabilize the motorhome when parked. The leveling system features a

remote control panel (located near the pilot seat). The multiple warning system that consists of a Jacks Down LED and warning alarm if a jack is down and the transmission is placed in gear or the park brake is released. The leveling system can be operated in manual or automatic modes.

Safety Features:

The leveling system has safety features to prevent a jack from extending during travel. The control panel will not activate until the following safety features are in place.

- ◆ The transmission is in Neutral.
- ◆ The parking brake is applied.
- ◆ The ignition switch is in the ACC or On position.

Remote:

The remote control panel includes four jack extend switches, an Auto switch, a MAN (manual) switch, a retract All Jacks switch and a power ON/OFF switch. A LED light next to a directional button indicates that position is low.

Indicator Lamps:

- ◆ **MAN** – Indicates system is in manual level mode.
- ◆ **AUTO** – Initiates Automatic level mode.
- ◆ **ON/OFF** – Turns the leveling system on or off.
- ◆ **JACKS DOWN** – Indicates one or more jack is extended.
- ◆ **LOW VOLTAGE** – Indicates chassis voltage is low.
- ◆ **ENGAGE PARK BRAKE** – Indicates the Park Brake is disengaged.
- ◆ The LED adjacent to any extend switch indicates that position is low.

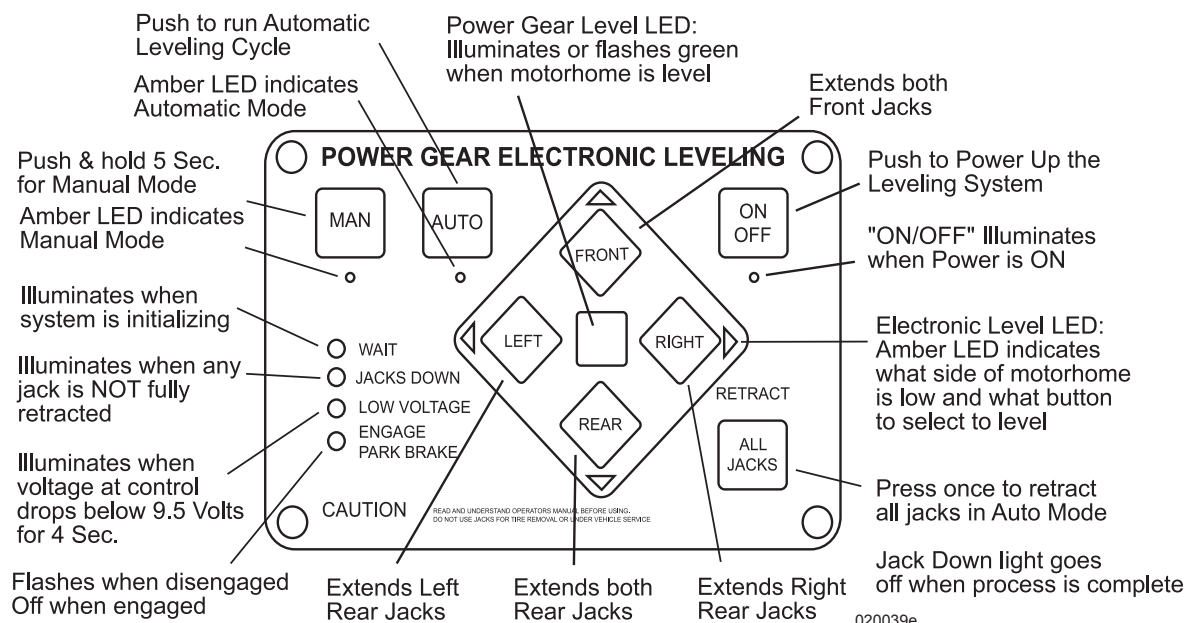

CAUTION:

The leveling jacks are not designed for changing tires. This can cause problems with the suspension system, frame alignment and damage to the windshield(s). Never use the jacks to elevate any wheel position off the ground.

CAUTION:

DO NOT move the motorhome while the jacks are still in contact with the ground or extended. Damage to the jacks can occur.

Prior to Leveling

- ◆ Chassis battery voltage must be at least 12 Volts DC.
- ◆ Select a level site if possible, or park the motorhome with the front facing downhill.
- ◆ Apply the parking brake. Place the transmission in Neutral.
- ◆ (Optional) Lower the air suspension (if applicable) by stepping on the brake several times until system air pressure is below 60 psi. With the ignition on, push and hold the Air Dump switch to lower the suspension. This reduces the amount the jack will need to extend before making contact with the surface.

CAUTION:

Survey the area around and under the motorhome for obstructions that can damage the motorhome or undercarriage components before lowering the air suspension. Damage to the mud flap may occur if it is located over a raised area.

CAUTION:

Ensure potential jack contact points are clear of obstructions or depressions before operation. Keep all people clear of the motorhome during leveling system operations. Never expose hands or other parts of the body near hydraulic leaks. Hydraulic lines are under high pressure. Oil leaks may cut and penetrate the skin causing serious injury.

CAUTION:

Hot asphalt, gravel or dirt may not support the weight that is placed on the hydraulic jack pads. Place thick plywood under the jack pads to help disperse the weight. If blocking up a rear jack pad to gain added clearance when the motorhome is on a slope, place a wheel chock at the opposite set of rear wheels to prevent the motorhome from rolling.

NOTE:

If additional height or surface support is needed, construct a 1' x 1' wooden block made from two pieces of $\frac{3}{4}$ " plywood for a total thickness of $1\frac{1}{2}$ ". Drill hole in corner and use awning wand to slide wooden block under jack pad.

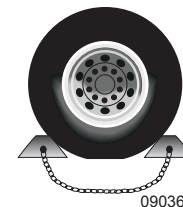

090368
Properly chock the wheels to prevent the motorhome from rolling.

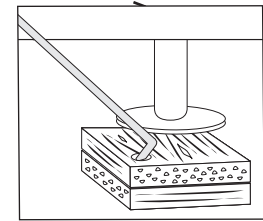
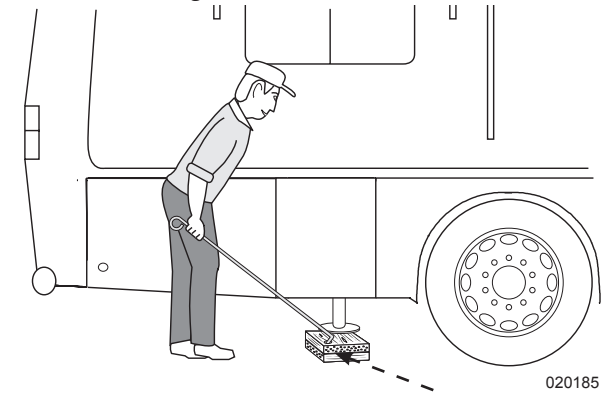
Manual Leveling

020185b
Wood Support Block

The manual leveling mode can be used for leveling or stabilization preference. An indicator lamp adjacent to an extend switch indicates that jack position(s) is low.

Manual Leveling Operation:

- ◆ Follow the instructions in *Prior to Leveling*.
- ◆ Turn the ignition switch to On or ACC position.
- ◆ Press the **ON/OFF** button to turn the system on.
- ◆ Press and hold the **MAN** (manual) button for five seconds. Once the indicator lamp below the **MAN** button illuminates, the system is ready.

CAUTION:

Prior to leveling the motorhome it is important that all jacks be in contact with the ground to stabilize and support the frame. No single jack should be solely used to level the motorhome. Applying an improper leveling process can cause excess torsion stress and/or twisting of the chassis, frame and body, resulting in damage to the windshield or an entry door malfunction.

- ◆ Extend the front jack(s) until contact with the surface is made. Extend an additional ½". This allows the front jack(s) to act as a pivot point.
- ◆ Extend the jack position according to the indicator lamp. Example: If the indicator lamp is lit under Jack Extend Switch - Rear, the rear of the motorhome is low. Press and hold the Rear button. Both rear jacks will extend. Once level, the system will automatically stop. The Power Gear Level Light will illuminate. Release the switch. Pressing Right or Left will extend a single rear jack accordingly.
- ◆ Turn off the remote panel.
- ◆ Turn off the Ignition switch.

Automatic Leveling

The automatic function of the leveling system should only engage when the site is relatively level and solid to prevent excessive twist/stress to the frame. It is essential that there is no movement in the motorhome prior to and during the automatic leveling process.

Automatic Leveling Operation:

- ◆ Follow the instructions in *Prior to Leveling*.
- ◆ Turn the ignition switch to On or ACC position.
- ◆ Press the ON/OFF button to turn the system on.
- ◆ Press the Auto switch. The pump motor activates and the appropriate jacks automatically extend and level the motorhome.

NOTE:

A Jacks Down warning light will illuminate when the jacks are extended. The alarm will sound if the jacks are down and the park brake is released or transmission placed in gear.

- ◆ The motorhome is level when the LED's next to Jack Extend switches are off and the green Power Gear Level light is illuminated.
- ◆ Turn off the remote panel.
- ◆ Turn off the ignition switch.

**NOTE:**

If additional height or surface support is needed, construct a 1' x 1' wooden block made from two pieces of ¾" plywood for a total thickness of 1½". Drill a hole in one corner and use the awning wand to slide the wooden block under the jack pad.

Retracting Leveling Jacks

- ◆ Turn the ignition switch to On or ACC.
- ◆ Confirm that the parking brake is applied.
- ◆ Turn On the remote panel.
- ◆ Momentarily press the All Jacks Retract button. If retracting in manual mode, the All Jacks button must be held until the Jacks Down LED goes out.
- ◆ Once the Jacks Down LED goes out, the jacks should be fully retracted. Make a visual inspection to ensure that all jacks have fully retracted before moving the motorhome.

INSPECTION:

Before moving the motorhome always perform a visual inspection to be sure that all jacks have fully retracted. Remove any debris that may be on the jack pad.

If the jacks fail to extend or retract:

- ◆ Apply the park brake, turn the ignition to the On or ACC position and place the transmission in Park.
- ◆ If jacks still do not operate, check the leveling system fuse in the front distribution box.

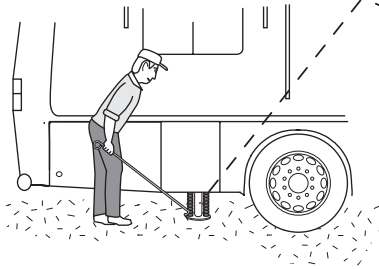
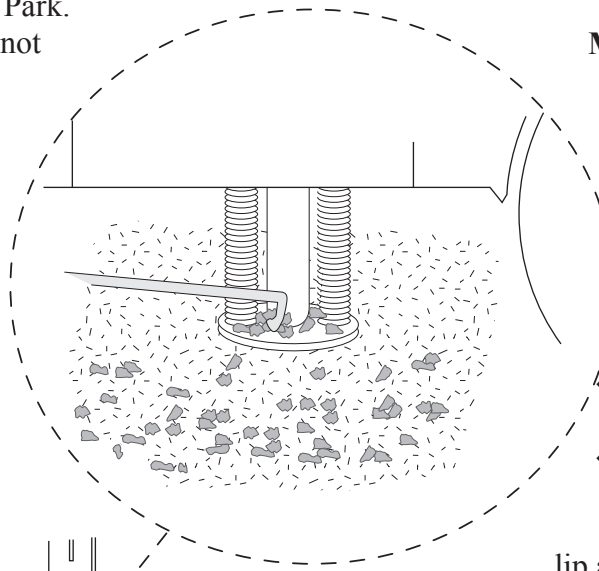

020185b

NOTE:

The hydraulic pump is equipped with an internal thermal breaker for protection against overheating. If the pump is used repeatedly in a short period of time the breaker will trip. It resets automatically in 5 to 30 minutes.

Drive-away Protection:

With the jacks extended and the park brake released, or transmission placed in gear, a warning alarm will sound and all LEDs will illuminate. The jacks will automatically

retract. A full visual inspection is required to confirm full retraction of jacks before moving motorhome.

Maintenance:

At weekly intervals, use silicone spray on the jack rod. This will help prevent moisture damage to surface of the jack rod. If parked near coastal areas, apply more often. Occasional oil or grease on the extended jack rod is normal.

- ◆ Remove dirt and road debris from the jacks as needed.
- ◆ Check the fluid level every month. The fluid level should be within 1/4" of fill port lip and checked with all jacks

retracted.

- ◆ Inspect and clean all hydraulic pump electrical connections every 12 months.
- ◆ For jacks equipped with a grease fitting at the bottom of the cylinder, two pumps of grease should be sufficient for 20 to 30 uses. **DO NOT** over grease. Damage to the rod seal will occur.
- ◆ Fluid change interval is 36 months.

Two pumps of grease every 20 to 30 uses. **DO NOT OVERGREASE.**

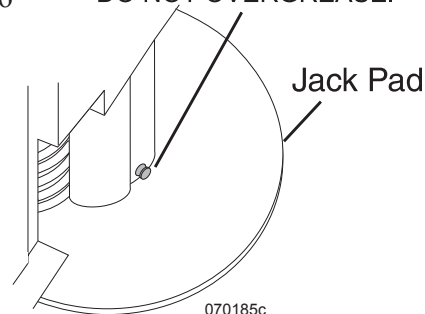

070185c

Adding Fluid:

If the leveling system makes unusual noise or the alarm sounds when driving around corners or over bumpy roads, this indicates a low fluid level.

1. Chock a wheel fore and aft for safety.
2. Ensure all jacks are retracted.
3. Unscrew the reservoir cap from the top of the pump. Slowly fill the reservoir with *Texaco Rando HD46* hydraulic fluid until 1/4" from the fill plug.
4. Replace the reservoir cap. The reservoir is now at the proper level.

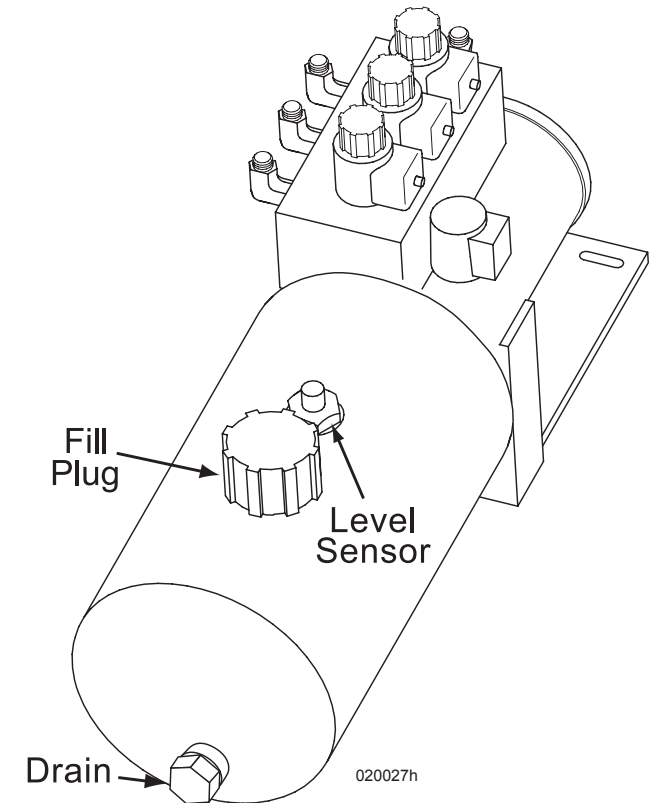

020027h

ENGINE - GENERAL INFORMATION

The diesel engine operates differently from the conventional gasoline engine. Gasoline engines control engine speed using a butterfly throttle plate controlling air/fuel mixture inlet flow. As the throttle plate opens, vacuum created by the piston velocity draws the metered fuel/air charge into the combustion chamber, then ignites from a controlled electric ignition source. Closing the throttle plate limits the fuel/air supply, slowing engine speed, increasing intake manifold vacuum.

The diesel engine in the motorhome controls engine speed by varying fuel supply only. No throttle plates are used. An exhaust driven turbine system (turbocharger) compresses the fresh air supply into the engine. The fuel is injected under pressure into the combustion chamber. Ignition of fuel/air charge occurs from heat generated by rapid high compression. The turbo boost gauge registers amount of intake manifold pressure measured in lbs./in². Therefore, no intake manifold vacuum exists.

Diesel engine RPM (revolutions per minute) operating speeds are generally much lower than that of the gasoline engine. Peak torque and horsepower output values occur at much lower engine speeds. Idle speeds between the two engine types are similar, however maximum engine speeds are quite different. The gasoline engine generally is not regulated to a maximum engine speed. The maximum engine speed on a diesel engine is controlled by an engine speed governor set by the engine manufacturer.

WARNING:

DO NOT operate a diesel engine where there are or can be combustible vapors. Vapors can be drawn through the air intake system and cause engine acceleration and over-speeding, resulting in fire, explosion and extensive property damage. Numerous safety devices are available, such as air intake shutoff devices, to minimize risk of an engine over-speeding where an engine (due to its application) might operate in a combustible environment, such as fuel spills or gas leaks.

INFORMATION:

The equipment owner and operator is responsible for safe operation of engine. Consult your engine manufacturers owners manual or authorized repair location for more information.

ENGINE DIAGRAM

Cummins - ISM - II Standard

- | | |
|----------------------------|------------------------------------|
| 1. Hydraulic Cooler | 20. Air Conditioning Compressor |
| 2. Charge Air Cooler | 21. Air Governor |
| 3. Tag Lift Solenoid | 22. Engine Diagnostic Plug |
| 4. Air Filter Minder | 23. Back-up Alarm |
| 5. Tag Axle Regulator | 24. Engine Front/Rear Start Switch |
| 6. Radiator | 25. Rear Run Box |
| 7. Electric Override Valve | 26. Hydraulic Oil Dipstick |
| 8. Thermo Valve | 27. Hydraulic Oil Reservoir |
| 9. Hydraulic Filter | |
| 10. Block Heater Outlet | |
| 11. Coolant Reservoir | |
| 12. Belt Tensioner | |
| 13. Alternator | |
| 14. Engine Oil Dipstick | |
| 15. Engine Oil Fill | |
| 16. Primary Fuel Filter | |
| 17. Filter Drain | |
| 18. Air Filter | |
| 19. Reel light | |

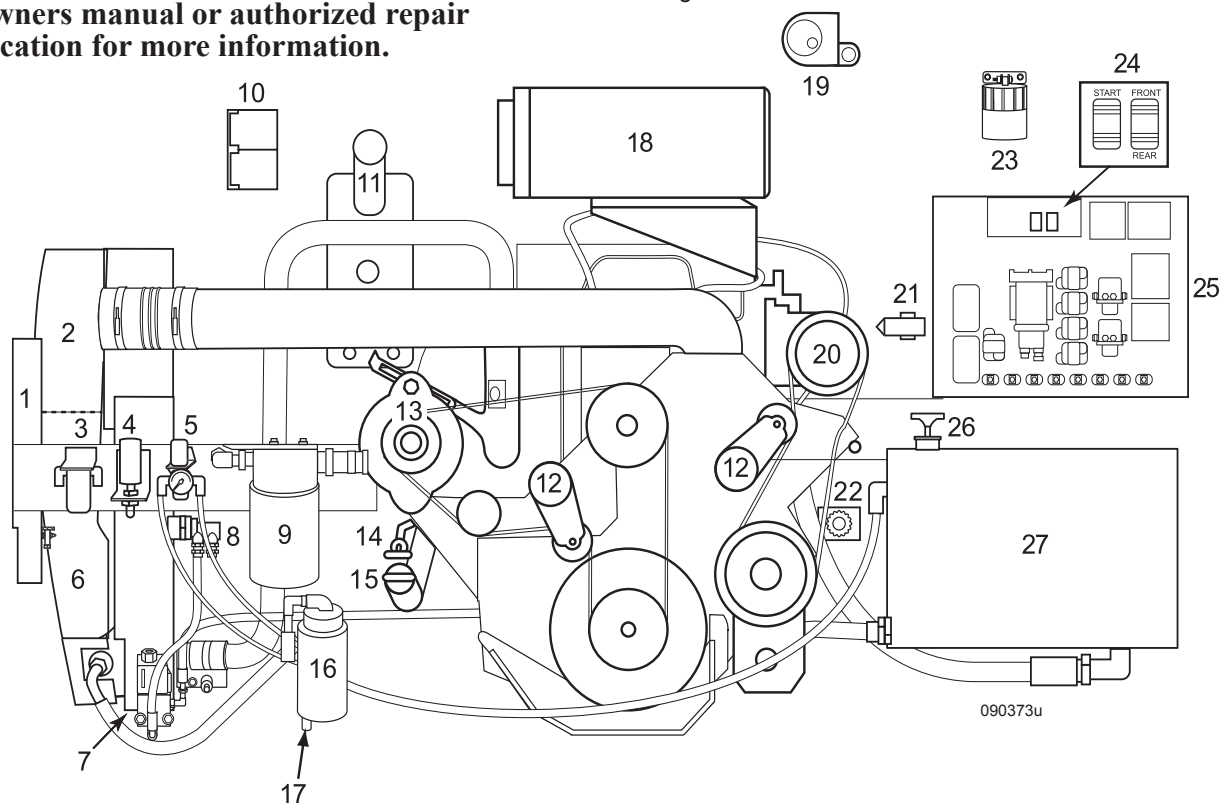

Cummins ISX (Optional)

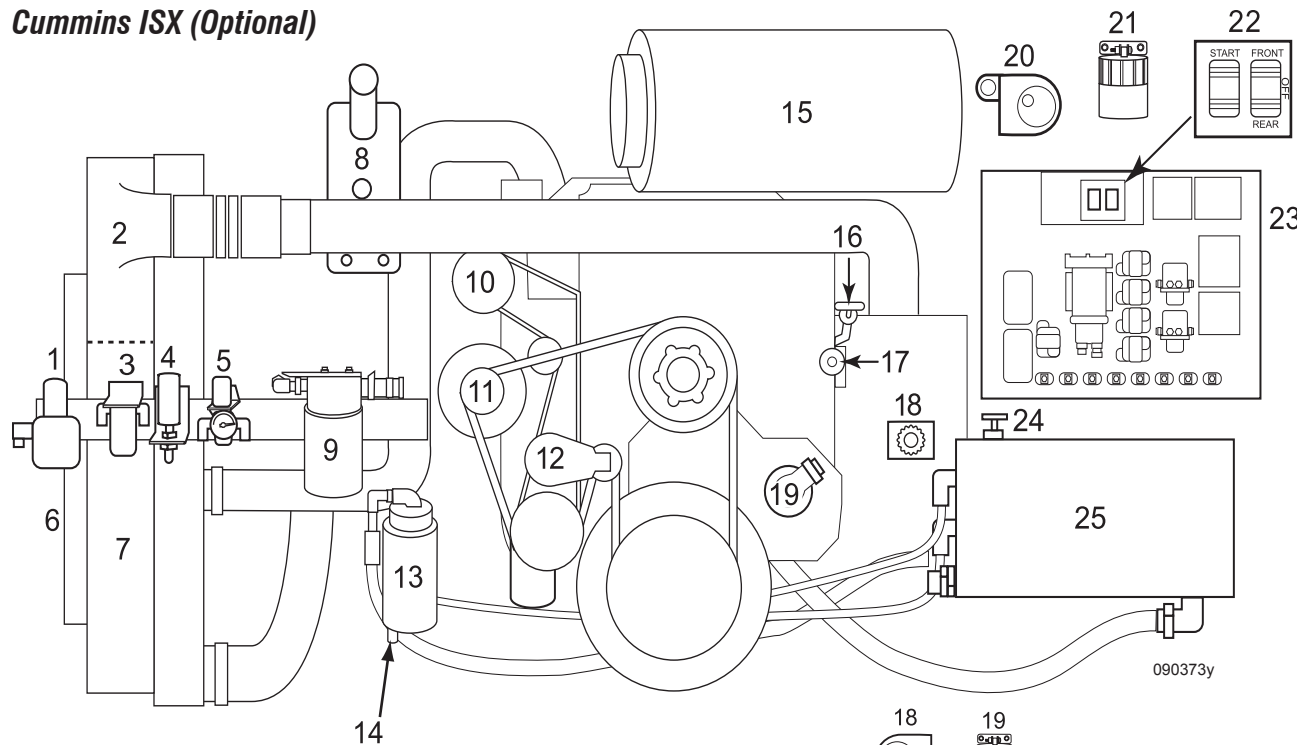

- 1. Hydraulic Fan Control Module
- 2. Charge Air Cooler
- 3. Tag Lift Solenoid
- 4. Air Filter Minder
- 5. Tag Axle Regulator
- 6. Hydraulic Cooler
- 7. Radiator
- 9. Hydraulic Filter
- 10. Air Conditioning Compressor
- 11. Alternator
- 12. Belt Tensioner
- 13. Primary Fuel Filter
- 14. Filter Drain
- 15. Air Filter
- 16. Engine Oil Dipstick
- 17. Air Governor
- 18. Engine Diagnostic Plug
- 19. Engine Oil Fill
- 20. Reel Light
- 21. Back-up Alarm
- 22. Engine Front/Rear Start Switch
- 23. Rear Run Box
- 24. Hydraulic Oil Dipstick
- 25. Hydraulic Oil Reservoir

Detroit Diesel (Optional)

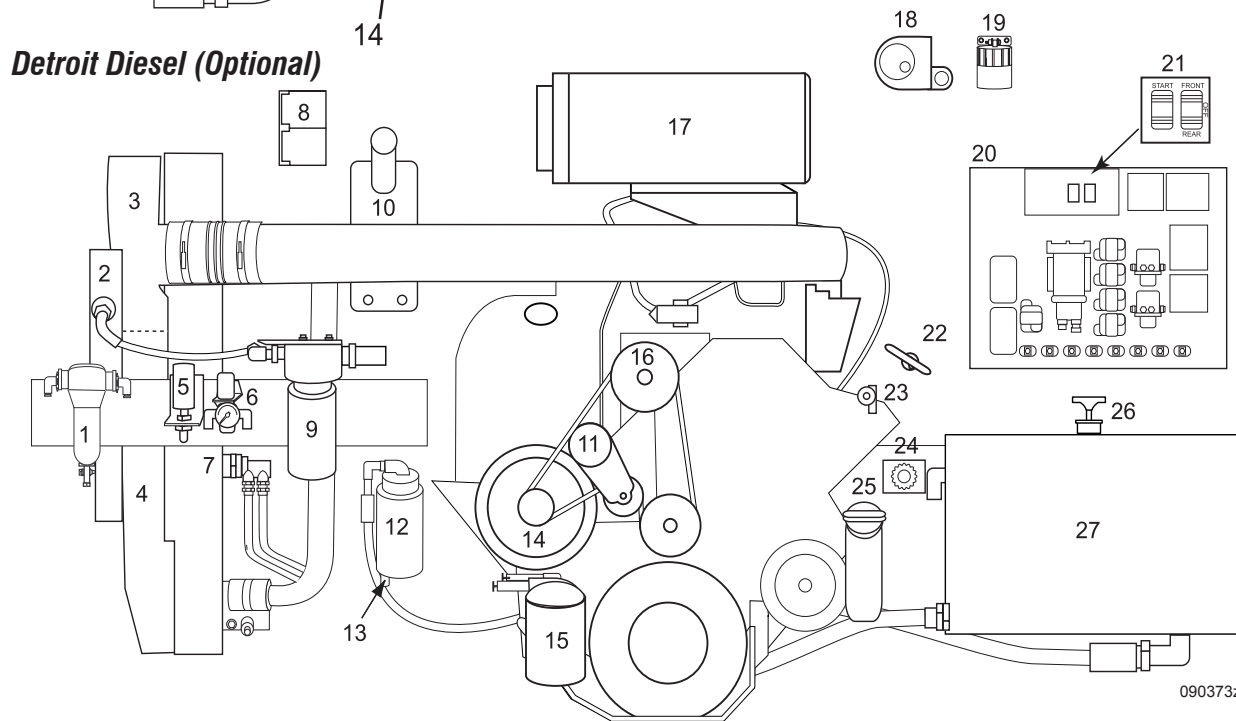

- 1. EGR Filter
- 2. Hydraulic Cooler
- 3. Charge Air Cooler
- 4. Radiator
- 5. Air Filter Minder
- 6. Tag Axle Regulator
- 7. Thermovalve
- 8. Block Heater
- 9. Hydraulic Oil Filter
- 10. Coolant Reservoir
- 11. Belt Tensioner
- 12. Primary Fuel Filter
- 13. Filter Drain
- 14. Alternator
- 15. Coolant Filter
- 16. Air Conditioning Compressor
- 17. Air Filter
- 18. Reel Light
- 19. Back-up Alarm
- 20. Rear Run Box
- 21. Rear Start Switch
- 22. Engine Oil Dipstick
- 23. Air Governor
- 24. Engine Diagnostic Plug
- 25. Engine Oil Fill Tube
- 26. Hydraulic Oil Dipstick
- 27. Hydraulic Oil Reservoir

STARTING PROCEDURE

Normal Starting

With the foot throttle in the idle position, turn the key to the start position. When the engine starts, release the key. Allow the engine to idle with no load for three to five minutes. Engine coolant temperature should be up to normal operating range (140° F / 60° C to 212° F / 100° C) before operating the engine under full throttle.

NOTE:

The engine does not have a “wait to start” feature.

NOTE:

It is recommended to not idle the engine for long periods of time. Consistent periods of long idle wastes fuel and may cause engine damage.

Cold Weather

In sub-freezing or extreme cold, engine oil becomes thick and battery output is reduced. Thick oil, combined with less amperage available from the battery, increases difficulty in starting the engine.

Depending on ambient temperature it may be necessary to pre-heat the engine. Located in the coolant passage in the engine is a heating unit that operates from 120 Volt AC. If it is necessary to pre-heat the engine due to ambient temperature, it is recommended to activate the block heater the night before, allowing several hours for the block heater to warm the engine.

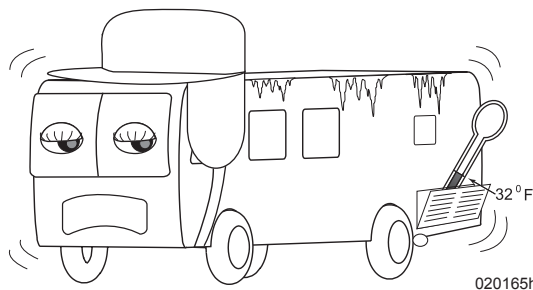

Another method to preheat the engine is to use the Aqua-Hot. The Aqua-Hot engine pre-heat function will heat engine coolant and the interior on the Aladdin.

It is possible to operate diesel engines in extremely cold environments when the engine is properly equipped with the correct lubricants, fuels and coolant. Cold weather operation can be defined in two categories: Winter and Arctic.

WINTER (32° to -25° F) (0° to -32°

C): Use a 50% antifreeze to 50% water coolant mixture, use multi-viscosity oil meeting manufacturers specifications and fuel to have maximum cloud pour points 10° F (6° C) lower than the ambient temperature in which the motorhome operates.

ARCTIC (-25° to -65° F) (-32° to -52° C): Use a 60% antifreeze to 40% water coolant mixture. Use oil meeting manufacturers specifications and fuel to have maximum cloud pour points 10° F (6° C) lower than the ambient temperature in which the motorhome operates.

INFORMATION:

Refer to the engine manufacturers Owner's Manual for more detailed information.

NOTE:

The engine is filled with Texaco URSA Super Plus SAE 15-40w multi-viscosity oil from the factory. Generally this will start the engine in temperature down to 15° F. If the engine has normalized to a temperature below 15° F it will be necessary to pre-heat the engine before starting.

CAUTION:

Upon cranking an engine in cold temperature, the starter may rapidly engage and disengage. If this occurs STOP attempting to crank the engine to prevent starter damage. Pre-heat the engine before making further attempts to start.

Block Heat:

The switch on the dash labeled Block Heat operates the receptacle for the block heater cord. The block heater is rated between 850 and 1500 watts, depending on engine size. For efficiency hook to shore power, or plug the block heater cord to a separate power cord rated for 15 Amps and a GFCI protected outlet rated at 20 Amps. The engine may require several hours of pre-heating before starting. It is recommended to start preheating the engine the night before departure.

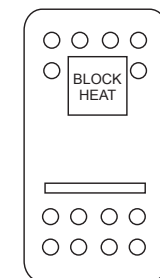

Switch 060066 located on dash.

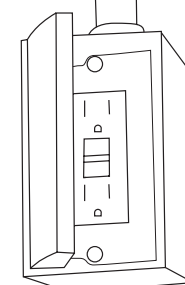

Outlet located in 090480 engine compartment.

To Use the Block Heater:

- ◆ Hook to shore power and plug the block heater cord into the block heater receptacle (both are located in the engine compartment).
- ◆ Turn on the Block Heat switch.

Aqua-Hot Engine Preheat

The diesel burner inside the Aqua-Hot heats an internal engine coolant loop. When the Aqua-Hot Engine Preheat switch is turned on, an engine coolant pump inside the Aqua-Hot circulates heated coolant through the engine. The time it takes for the Aqua-Hot to preheat the engine depends on ambient temperature. Allow at least three hours of preheating before attempting to start the engine.

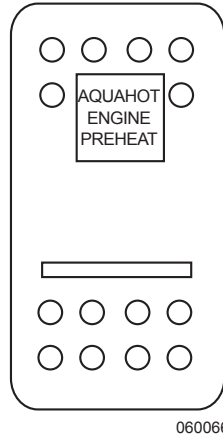
**To Use the Engine Preheat System:**

- ◆ Press the Aqua-Hot switch at the kitchen to turn the system on.
- ◆ Turn the Aqua-Hot Engine Preheat switch at the dash to the **ON** position. This activates the engine pump inside the Aqua-Hot.

Tips:

1. When operating below 32° F, the Aqua-Hot and/or block heater preheat can enhance engine starting by easing cranking and helping to prevent engine misfire and white smoke during starting.
2. Always follow the recommended oil, fuel, and coolant specifications as outlined in the OEM Engine Manual. Proper oil viscosity and coolant concentration eases engine starting and helps to avoid engine damage.
3. Allow the engine to idle until it sufficiently warms for operation. Utilize the fast idle feature to quicken the process. Wait to operate the motorhome for at least three minutes or until the coolant temperature begins to rise.
4. Check the air inlet and filter daily, or as necessary, when driving in snow conditions.
5. The demand on batteries increase during winter; check and service the batteries frequently to help ensure trouble-free starts.
6. Start out slowly with the motorhome to allow the transmission and axle lubricants time to circulate and warm before putting them under full load.

WARNING:

DO NOT use ether cold starting additives to start the engine as damage may occur.

ENGINE OIL**Cummins Engine Requirements:**

The maintenance guidelines in the Cummins Operation & Maintenance Manual are the recommendations for the engine to extend the engine life and improve performance, resulting in cost efficient operations. A good maintenance schedule begins with a daily awareness of the engine and its various systems.

A high grade 15W-40 multi-viscosity heavy duty lubricating oil meeting Cummins Engineering Specification CES 20071 or CES 20076, American Petroleum Institute (API) specification CH-4 which can be used as an alternative to CES 20071 is recommended. Lubricating oils meeting API CG-4 specifications may be used at a reduced drain interval. A critical factor in maintaining engine performance and durability is the use of high grade multigrade lubricating oil and strict adherence to the maintenance service intervals.

A straight weight or monograde lubricating oil is not recommended. Shortened drain intervals may be required as determined by a close monitoring of the lubricating oil condition by means of an oil sampling program. The use of oil analysis to extend drain interval is not recommended. There are numerous variables which is the basis of the recommendation.

Synthetic oils API category III specifications are recommended for extreme cold temperatures only. Low viscosity oils used for winter operations will aid in starting. Synthetic oils, or oil with adequate low temperature properties used for Arctic operations where the engine cannot be kept warm when shut down, will aid in starting. The use of synthetic oils should not be used to extend drain intervals. Extended oil change intervals can decrease engine life and possibly affect the engine warranty.

Oil additives should not be used unless the oil supplier or oil manufacturer has been consulted and provided positive evidence or data establishing satisfactory performance in the engine.

NOTE:

The engine does not require a “break-in” procedure.

INFORMATION:

Refer to the Engine Manufacturers Owners Manual for details on the oil maintenance schedule.

NOTE:

The Engine is filled with Texaco URSA Super Plus SAE 15W-40 multi-viscosity oil from the factory.

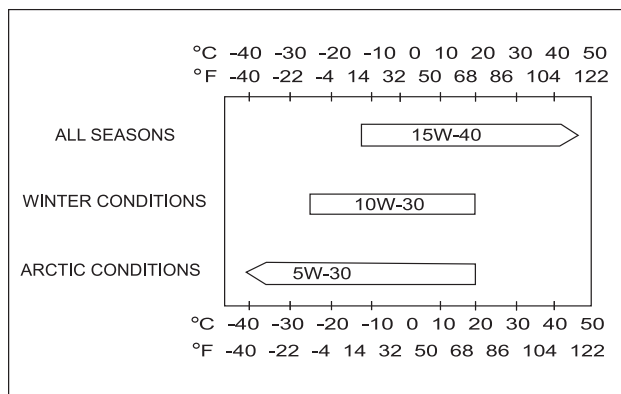

Lubricating oil recommendations and specifications. 070201

Detroit Engine (Optional) Requirements:

The maintenance guidelines in the Detroit Diesel Engine Operators Guide are the recommendations for the engine to extend the engine life and improve performance, resulting in cost efficient operations. A good maintenance schedule begins with a daily awareness of the engine and its various systems.

A high grade 15W-40 multi-viscosity heavy duty lubricating oil meeting Detroit Diesel requirements, American Petroleum Institute (API) specification CI-4, is recommended for EGR equipped Engines.

A critical factor in maintaining engine performance and durability is the use of high grade multigrade lubricating oil and strict adherence to the maintenance service intervals. At temperatures below -20F 5W-XX and 10W-XX oils may be used provided they are API CI-4 rated for EGR equipped engines. Low viscosity oils, used for winter operations, will aid in starting.

CAUTION:

Monograde lubricating oil is not recommended.

CAUTION:

DO NOT use oil analysis to extend drain intervals.

Synthetic oils may be used in Detroit Diesel engines provided they are API licensed and meet the performance and chemical requirements of non-synthetic oils outlined in the Detroit Diesel Engine Operators Guide. Synthetic oils can improve low temperature flow properties and high temperature oxidation resistance. Synthetic oils, or oil with adequate low temperature

properties used for Arctic operations where the engine cannot be kept warm when shut down, will aid in starting. The use of synthetic oils should not be used to extend drain intervals. Extended oil change intervals can decrease engine life and possibly affect the engine warranty.

Oil additives should not be used in the Detroit Diesel engines. Lubricants meeting the Detroit Diesel specifications outlined in the Operators Guide contain a balanced additive treatment. Supplemental additives are generally not necessary and can be harmful.

NOTE:

Engine damage resulting from use of supplemental oil additives is not covered by Detroit Diesel Corporation warranty.

NOTE:

The engine does not require a “break-in” procedure.

NOTE:

The Engine is filled with Texaco URSA Super Plus SAE 15W-40 multi-viscosity oil from the factory.

ENGINE SHUTDOWN

Allow the engine to idle three to five minutes after a full load operation. This allows adequate cool down of pistons, cylinders, bearings and turbocharger components. Under normal driving conditions, exiting the highway is generally lighter engine operation and the need for the three to five minutes is not necessary.

Extended Engine Shutdown

When the motorhome has been sitting for 30 days or more, verify all the fluid levels are correct. Follow the normal starting procedures. If the oil pressure gauge does not register within 15 seconds, shut off the engine immediately to avoid damage. Consult the engine manufacturer's owner's manual for guidelines on troubleshooting low oil pressure, or contact a qualified service technician. Allow the engine to idle for five minutes before operating under a load.

COOLANT SYSTEM

A fully formulated antifreeze or coolant containing a pre-charge of Supplemental Coolant Additives (SCA) is recommended to significantly simplify coolant system maintenance. The difference between fully formatted antifreeze and fully formatted coolant is the percentage of water. Both contain balanced amounts of antifreeze, SCA, buffering compounds and a percentage of good clean quality water. The antifreeze of coolant must meet ethylene glycol or propylene glycol recommendations.

Clean, quality water in a 50/50 ratio (40 to 60% working range) mixed with fully formatted antifreeze will provide protection from -34° F to 228° F. The 50/50 mix ratio must be premixed prior to being put in the system. Placing antifreeze and water in the cooling system is not recommended. Consult the manufacturer's OEM for more details.

Coolant System Overheated:

If the engine is overheated do not pour cold coolant into the hot engine. Sudden change in temperature may crack the cylinder head or block. If the engine is hot, fill slowly to prevent rapid cooling and distortion of engine castings.

Coolant System Frozen:

If the coolant system freezes, the motorhome must be towed to a warm area until completely thawed. If the engine is operated when the cooling system is frozen it can result in engine overheating due to insufficient coolant circulation. Once thawed, check engine, radiator and related components for damage caused by expansion of frozen coolant.

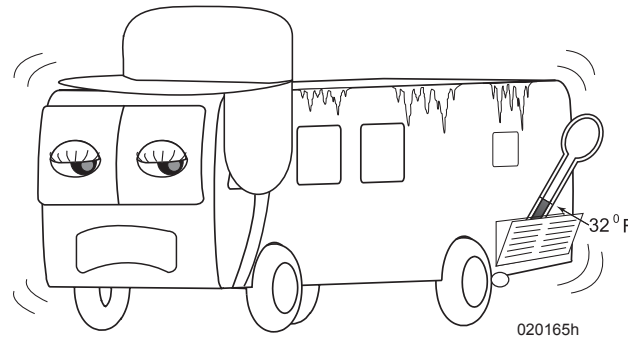

NOTE:

An over concentration of antifreeze, or the use of high silicate antifreeze, can cause damage to the coolant system and engine. Antifreeze is essential in every climate.

WARNING:

Do not continue engine operation when engine warning light illuminates and the engine begins to de-rate in power output. Continued operation will result in engine damage.

NOTE:

Consult the engine manufacturer owners guide for more detailed information.

Engine Coolant Reservoir:

The engine coolant reservoir is connected to the radiator by a hose. When the motorhome is driven, coolant heats and expands. A portion of fluid, displaced by expansion, flows from the radiator into the reservoir. When the engine is stopped the coolant cools and contracts. Coolant is drawn back in the radiator by a vacuum. Thus, the radiator is kept filled with coolant to the desired level at all times resulting in increased cooling efficiency. The coolant level should be at, or slightly above, the appropriate mark on the reservoir tank when the system is cold.

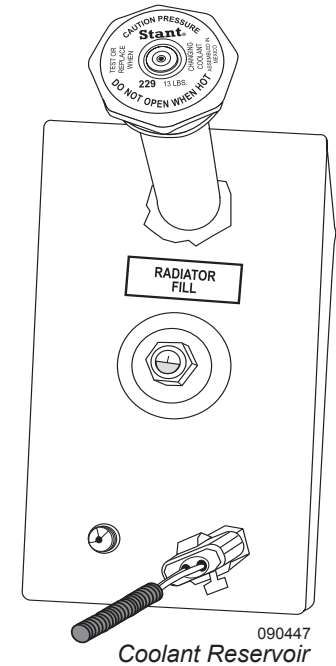

CAUTION:

To avoid scalding hot steam or coolant from being released from the engine cooling system, never remove the reservoir cap while the engine is running or hot. Failure to follow this warning may result in damage to the engine cooling system and possibly cause severe personal injury.

Coolant Levels:

- ◆ Check the coolant level daily or when refueling.
- ◆ If the coolant is below the minimum level, the low coolant alarm will sound and the low coolant light will appear on the dash.

INSPECTION:

Stop the motorhome and inspect the coolant level before continued operation.

INFORMATION:

Refer to the Engine Manufacturer Owner's Manual for details on engine coolant maintenance.

NOTE:

Have an inspection performed of the surge tank cap seal and have the cap pressure tested at each oil change.

Factory Fill Coolant Types:

- ◆ Cummins - Texaco 50/50 with bitterant and 2 qts SCA.
- ◆ Detroit Series 60 - Fleet Charge 50/50 fully formulated with SCA.

INFORMATION:

Refer to OEM manual for detailed antifreeze information.

Radiator/Charge Air Cooler

The diesel engine uses compression to ignite the fuel/air charge. To increase compression inside the combustion chamber (resulting in increased power output) a turbocharger is added to the engine. The turbocharger is a paired housing assembly with impellers inside each housing connected by a common shaft. One impeller is propelled by the engine exhaust, which drives the other impeller. The function of the other impeller is to increase compression inside the combustion chamber by forcing air into the intake manifold.

This process works well, however, the intake air charge is heated two different ways: through convection by the exhaust gases driving the turbocharger and when air is compressed. This negative effect inside the combustion chamber results in lost power potential. Therefore, a Charge Air Cooler (CAC) is installed to cool the intake air before it enters the engine. The CAC performs the same function as a radiator, cooling air instead of liquid. Ambient air passing through the CAC will cool the engine intake air charge.

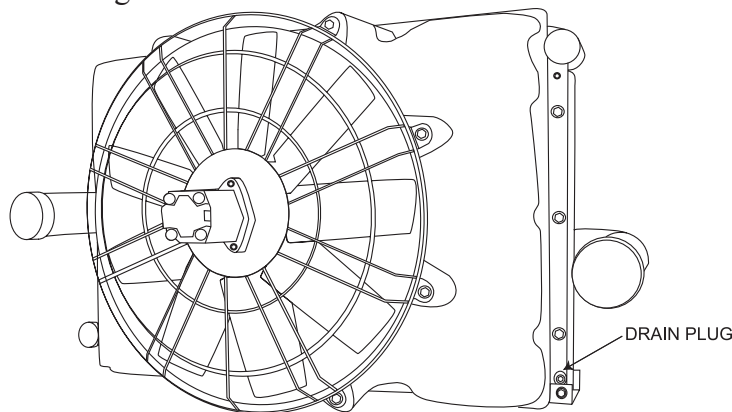

BACK OF RADIATOR SHOWN

090452

After leaving the turbocharger, intake air is compressed and heated to approximately 300° to 375° F., depending on the engine load and throttle position. Before air enters the intake manifold, the CAC cools the intake air temperature to the engine manufacturer specifications. Lowered intake air temperatures reduce exhaust emissions, improve fuel economy and increase horsepower. The CAC will continually expand and contract up to ¼" as throttle increases and decreases.

Cleaning and Maintenance:

- ◆ Regular maintenance includes draining the engine coolant, flushing/cleaning the cooling system, **inspecting** the water pump standpipe, replacing the thermostat, gasket and seal, and replacing the coolant and SCA element.
- ◆ **Inspect** the charge air cooler every six months and remove dirt and debris that may block the fins. If the motorhome develops an oil leak, there is a possibility that the oil will coat the fins of the CAC. Dust will adhere to the oil film, clog the fins and reduce cooling efficiency. When the oil leak is repaired, the CAC must be thoroughly cleaned.

- ◆ During each oil change **inspect** the engine side of the radiator/CAC assembly for foreign objects that may cause restriction.
- ◆ Spraying degreaser on the charge air cooler, as well as using a steam cleaner, will not damage the CAC. **However, pressure washer and steam cleaner nozzles placed too close to the CAC can bend the fins.** The recommended cleaning procedure for the CAC and the radiator is to use a bucket of mild soap and water. Carefully wash with a bristle brush then rinse using a garden hose, with minimum water pressure, standing back a distance to avoid bending the fins.
- ◆ When performing maintenance, it is also necessary to **inspect** other components of the cooling system. The charge air cooler and radiator also requires an **inspection** for cracks, broken welds, secure mounting, and general cleanliness.

Coolant Hoses:

Rotten, swollen and worn hoses, as well as loose connections, are frequent causes of coolant system problems. Overheating can be caused by a collapsed hose or a clog caused by rubber shedding from a rotten hose. Replace any hose found to be cracked, swollen or damaged. Connections should be **inspected** periodically and hose clamps tightened.

Every 12 months:

Inspect all hoses, clamps, and fittings for leaks due to cracking, softness, and loose clamps/fittings. Look for signs of fluid leaks, damaged end fittings, ballooning, chafed, kinked, or crushed hoses, and loose clamps and fittings. Correct any deficiencies found.

BRAKE - AUXILIARY (Engine Brake)

Auxiliary braking systems are designed to supplement the standard air braking system. These devices are not designed to bring the motorhome to a complete stop; however, can assist in controlling the speed of the motorhome. Use of the engine braking system can extend the life of pads, shoes, rotors and drums, saving on costly service brake repairs.

The engine-braking device operates on a different principle than an exhaust brake. An engine brake functions by releasing engine compression. The effect of the engine brake increases with engine speed. When the engine brake is activated the Allison transmission automatically downshifts, utilizing the gear selected and maximizing the engine braking effect.

When the engine brake activates, an electrical signal is sent to the engine ECM (electronic control module). The ECM controls a hydraulic circuit that opens the exhaust valves near the end of the compression stroke. The potential engine braking power depends on turbocharger boost pressure, engine speed, compression ratio, injector timing and when the exhaust valves open.

Located on the left console is the **Engine Brake** switch and the **HI/LOW** switch. The **Engine Brake** switch engages the auxiliary braking system on the motorhome engine. Switching **HI** or **Low** allows for the selection of different levels of engine braking power. Selecting **LOW** activates the engine brake on three cylinders. Selecting the **HI** setting activates the engine brake on six cylinders.

The engine brake will not be active when:

- ◆ Engine speed goes below 850 RPM.
- ◆ An electronic fault code is active.

Applying the service brakes will disengage the cruise control. Use the engine brake when traveling down a hill, on the freeway or exiting the off ramp. The engine brake will allow the engine temperature to decrease while going downhill.

NOTE:

Idle the engine three to five minutes at approximately 1000 RPM to warm the engine before activating the engine brake. Do not operate the engine brake until the engine oil temperature is above 30° C (86° F).

WARNING:

The engine brake is designed to assist the motorhome service brakes, not for stopping.

TRANSMISSION

The Allison World transmission incorporates the **World Transmission Electronic Control (WTEC)** system. The system is comprised of five major components connected by a wiring harness: the Electronic Control Unit (ECU), engine throttle position sensor, three speed sensors, remote shift selector (keypad) and the control module. The ECU processes information received from the throttle position sensor, speed sensor, pressure switch and shift selector to provide optimum shift quality. This is accomplished by matching transmission and engine RPM during a shift to establish a desired shift profile within the ECU. Another feature of the transmission is the ability to “learn” or “adapt.” The electronic control system optimizes shift quality by using “Adaptive Shifting.” A wide variety of varied shift conditions is required before optimizing shift quality. Generally, five typical shifts of a consistent shift type are needed to optimize shift quality.

Shift Selector

The keypads on the shift control are **R** (Reverse), **N** (Neutral), **D** (Drive), Arrow up, Arrow down, Mode button. A digital display window shows gear selection, various transmission modes, oil level and transmission fault codes. Generation 4 keypads have a split screen displaying two number sets while in drive. The left number displays the highest forward range available. The right number is the range that the transmission is currently in. **NN** (Neutral) will appear in the display window when the ignition is turned On. This indicates

the transmission is in neutral and it is safe to start the crank. If the **NN** does not display when the ignition is turned on, there is no power to the shift selector and the transmission will not allow the engine to start. No display is an indicator of electrical problems with the engine batteries, ECU or the shift selector.

Keypad Functions:

- ◆ Select the Reverse gear by pressing **R**. **RR** will display.
- ◆ Select Neutral by pressing **N**. The area around the **N** button has a raised ridge so the driver can orient his hand to the push buttons by touch without looking at the display.
- ◆ Select Drive range by pressing **D**. The highest forward gear (6th gear) appears in the display and the transmission will shift to first gear indicated as 6 1.
- ◆ The Up and Down arrow buttons are used to select a higher (if not in “6”) or lower (if not in “1”) forward range. These buttons are not functional in Neutral or Reverse.
- ◆ When in Drive, one press changes the gear range selected by one. If the button is held continuously, the selected range will continue to change up or down until the button is released or until the highest/lowest possible range of gears is selected.

- ◆ The Mode button enables a secondary shift point to be selected. This is commonly referred to as Economy mode. Economy mode affects the upshift schedule 3-4, 4-5, 5-6 and downshift schedule 6-5, 5-4, 4-3. During highway driving, with the cruise control set between 55 and 65 m.p.h., setting the transmission to economy mode will eliminate about 99% of transmission downshifts from sixth to fifth when incurring a slight incline or overpass.

CAUTION:

Do not use Economy Mode in heavy stop and go traffic or mountainous terrains. Frequent shifting while using heavy throttle occurs in Economy Mode and increases transmission fluid temperature. Exit Economy Mode until road conditions improve.

NOTE:

The Mode button is used by the service technician to access diagnostic codes when troubleshooting. The diagnostic circuitry must be enabled to display.

CAUTION:

Engine temperature may rise when ascending long grades using full throttle. Towing a load will increase the demand on the engine. If this occurs, manually shift the transmission to the next lower gear and use less throttle. The engine will use less fuel and RPM should increase.

NOTE:

The transmission will not accept a manually selected gear change to occur if the gear selected is out of the specified operating range.

NOTE:

The transmission will not shift into gear from Neutral if the engine RPM is at or above 900. The display will flash “66” indicating the engine RPM is excessive. Select “N” and lower engine RPM.

Check Trans Indicator

The electronic control system of the transmission is programmed to alert operator of a problem with the transmission system, and reacts automatically to protect the motorhome and transmission from damage. Normally, the Check Trans indicator on the speedometer LCD will display when there is an error condition. The indicator will go out after the engine has started. The transmission system should be checked immediately if the Check Trans indicator displays. The Check Trans warning indicates the ECU has detected a fault and recorded a diagnostic code. The Check Trans warning is accompanied by a flashing display from the shift selector.

The shift selector display shows the actual range attained and the transmission does not respond to shift selector requests when the ECU detects a Do Not Shift (DNS) condition. Indications from the shift selector inform the operator that the transmission is operating at reduced capabilities. The transmission generally will downshift to 4th gear. The torque converter will not “lock-up” and engine speed

is automatically reduced. Direction changes (i.e. forward to reverse) will not be allowed. This allows time to find a safe place to park the motorhome to prevent transmission damage. If the engine is shut off, then started after a Check Trans indication, the transmission remains in Neutral until the fault has been corrected. Service should be performed immediately in order to minimize potential damage to the transmission.

NOTE:

Contact an authorized Allison Transmission service center whenever a transmission related concern arises. For some problems, fault codes may be registered without the ECU activating the Check Trans indicator. An authorized Allison Transmission Service center will have the equipment to check diagnostic codes and correct problems that may arise.

Diagnostic Codes:

The shift selector can be used to display transmission malfunctions as numerical codes. Each code is a two-digit main code and a two-digit sub code. These codes will fall in two classes: active and inactive. Active codes are codes currently affecting the ECU process and transmission operation. Inactive codes are retained in memory but may not affect the ECU process or transmission operation. A service technician will activate Diagnostic mode or hook an electronic display (Pro-Link) to the data plug to retrieve diagnostic codes. A maximum of five codes, D1 to D5, may be listed at one time. The highest priority code will be listed in D1. The Mode button will enable selection of sequential

codes. Allison 4th Generation controls list each code consisting of five characters. The first being a letter followed by a four digit number string. The most severe or recent code is listed in the ECU memory first with a maximum of five codes being d1 to d5 possibly listed at the same time. When new codes are added, the oldest inactive codes will be dropped.

To Display Diagnostic Codes:

- ◆ Stop the motorhome at a safe location.
- ◆ Apply the parking brake.
- ◆ Simultaneously press the up and down arrows once to enter oil level display mode. Then press the up and down arrows again to enter diagnostic mode.
- ◆ The codes will display one digit at a time or two characters at a time on 4th Generation controls.
- ◆ Press the mode button to scroll through the codes.
- ◆ Record all diagnostic codes that are displayed. The codes then can be used by an Allison Service Center for evaluation and repair.
- ◆ Hold the Mode button for ten seconds to clear both inactive and active codes.

Some codes are self-clearing while others will require service or ignition on/off cycles to clear.

Periodic Inspections

The Allison MH Series requires very little maintenance. Careful attention to the fluid level, electrical connections and hydraulic hoses is very important.

The transmission should be kept clean for easy inspection. Make periodic checks for loose bolts and leaking fluid. Check the condition of the electrical harnesses regularly. Check the engine cooling system occasionally for evidence of transmission fluid that would indicate a faulty oil cooler. Report any abnormal condition to an Allison Service Center.

Prevent Major Problems:

Help the control system oversee the operation of the transmission. Minor problems can be kept from becoming major problems if an Allison Transmission Service center is notified when one of these conditions occur:

1. Shifting feels odd.
2. Transmission leaks fluid.
3. Unusual transmission-related sounds (sound made by normal engine thermostatic fan cycling when climbing a long grade with a heavy load are often mistaken for transmission-related sounds).
4. The Check Trans indicator comes on frequently.

TRANSMISSION FLUID & FILTERS

The transmission is filled with TranSynd™ synthetic transmission fluid at the factory.

TranSynd™ synthetic transmission fluid extends service intervals. A small tag has been attached to the dipstick identifying

that the transmission is filled with TranSynd™ synthetic transmission fluid.

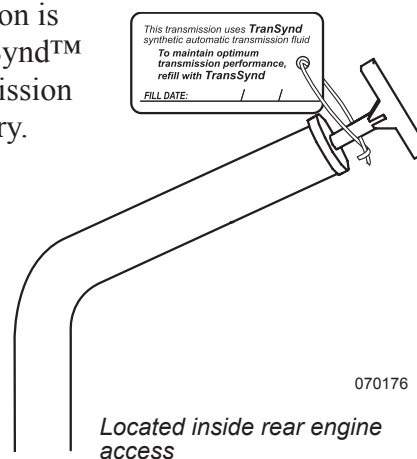

Fluid and Filter Change Interval:

The transmission has two filters: a main filter and a lube filter. Change the main filter at the first 5,000 miles. Thereafter follow the service intervals listed in the transmission **OEM (Original Equipment Manufacturers)** manual. Fluid and filters may require changing earlier than recommended in the transmission OEM manual, depending on the severity of operating conditions. Fluid must also be changed whenever there is evidence of dirt or high temperature operation as indicated by discoloration, strong odor or fluid analysis. Local conditions, severity of operation or duty cycle will dictate more or less frequent service intervals.

CAUTION:

DO NOT mix Dexron III® transmission fluid with TranSynd™ Synthetic transmission fluid.

NOTE:

Be sure to retain the receipt for proof of the initial Main filter change. Refer to the Allison transmission owner's manual or contact an authorized Allison service center for service intervals.

Proper Fluid Levels:

Transmission fluid cools, lubricates and transmits hydraulic power. Proper fluid levels must be maintained at all times. If fluid level is too low, the converter and clutches do not receive an adequate supply of fluid. If fluid level is too high, the fluid can aerate. Aerated fluid can cause the transmission to shift erratically or overheat.

An **Oil Level Sensor (OLS)** is built into the transmission. The fluid level can be checked easily and cleanly using the shift selector. Check the transmission fluid level before each trip and after removing the motorhome from storage.

Fluid Level Check from the Shift Selector:

To Enter Oil Level Sense Mode:

- ◆ Park the motorhome on a level surface. Place the transmission in “N” and set parking brake.
- ◆ The transmission temperature must be at least at operating temperature or an error code will appear.
- ◆ The motorhome must be stationary and in Neutral for approximately two minutes to allow the fluid to settle in the sump.
- ◆ The engine must be idling lower than 800 RPM.
- ◆ Simultaneously press the Up and Down buttons once.

The transmission is now in Oil Level Sense mode. The display will indicate one character at a time. An “o” followed by “L” represents oil level check mode. One of the following will be indicated:

Common Oil Level Fault Codes

Display	Cause of Code
o,L - O,X	Setting time too short
o,L - 5,0	Engine speed (RPM) too low
o,L - 5,9	Engine speed (RPM) too high
o,L - 6,5	Neutral must be selected
o,L - 7,0	Sump fluid temperature too low
o,L - 7,9	Sump fluid temperature too high
o,L - 8,9	Output shaft rotation
o,L - 9,5	Sensor failure

- ◆ “o K” represents the level is okay.
- ◆ “Lo” represents a low fluid level followed by a numeric indication of the number of quarts needed fill the sump.
- ◆ “HI” represents an overfull condition followed by a numeric indication of the number of quarts the sump is overfull.
- ◆ A countdown of flashing numbers indicates the fluid is still settling. When the fluid has stabilized in the sump, the true level will be indicated.
- ◆ If an “o” “L” “-” followed by a number displays, the oil level sensor could not read the level due to one of conditions listed in the “Common Oil Level Fault Codes” chart.
- ◆ Exit by pressing “N.”

Cold Check - Manual Check Procedures:

The concept of a cold check is to determine adequate fluid level for safe operating such as after a fluid and filter change. A cold check should be performed after transmission maintenance or service until a hot fluid level check or fluid level check from the shift selector can be performed.

To Check the Fluid When Cold:

- ◆ Park the motorhome on a level surface. Set the parking brake.
- ◆ Chock the wheels to prevent the motorhome from moving.
- ◆ Start the engine.
- ◆ Allow the engine to run at idle (500 to 800 RPM) for one minute.

- ◆ Apply the service brakes and shift to **D (Drive)**, then to **N (Neutral)** and next to **R (Reverse)** to fill the system. Shift the transmission to **N (Neutral)** and release the service brakes. Allow the engine to idle at 500 to 800 RPM.
- ◆ Remove the dipstick and wipe clean. Reinsert the dipstick fully into the tube, then remove to check fluid level. Repeat to verify reading, if needed.
- ◆ Safe operating level is anywhere within the Cold Check band on the dipstick. This allows safe operation of the transmission until a Hot Check or fluid level check from the shift selector can be performed.
- ◆ If the level is not within this band, add or drain the fluid as necessary to put the level to the middle of the Cold Check band.
- ◆ Perform a fluid level check from the shift selector or a Hot Check at the first opportunity when normal operating temperatures are reached.

CAUTION:

Low or high fluid level can cause overheating and irregular shift patterns. These conditions can damage the transmission if not corrected.

Fluid Levels - Hot Check

Fluid level rises as temperature increases. Fluid must be hot to ensure an accurate check. Be sure fluid has reached normal operating temperature. If a transmission temperature gauge is not present, check the fluid level when the engine water temperature gauge has stabilized and the motorhome has been driven for at least one hour.

- ◆ Park the motorhome on a level surface and shift to **N (Neutral)**. Apply the parking brake and allow the engine to idle (500 to 800 RPM).
- ◆ After wiping the dipstick clean, check the fluid level. Safe operating level is anywhere within the Hot Run band on the dipstick.
- ◆ The width of the Hot Run band is approximately one quart of fluid at normal temperature range.
- ◆ If the level is not within this band, add or drain the fluid as necessary to put the level within the Hot Run band.
- ◆ Ensure that fluid level checks are consistent. Check the level more than once. If readings are not consistent, ensure the transmission breather is clean and not clogged. If readings are still not consistent, contact the nearest Allison Service Center.

FUEL SYSTEM Fuel Requirements

Low sulfur #2 diesel fuel or #1 and #2 commercial winter blend diesel fuels are the most common commercially available and recommended for use.

The use of #2 diesel fuel will result in optimum engine performance. Try to obtain fuel from sources that are serviced often such as large truck service facilities. The fuel supply is fresh and the possibility of introducing contaminants or water into the fuel system is reduced. It is important to not empty the engine of fuel. The fuel system on the engine is sensitive to air. If the engine is allowed to run out of fuel, the fuel system will need to be thoroughly primed before the engine will start.

WARNING:

DO NOT mix gasohol with diesel fuel. This mixture can cause an explosion.

NOTE:

Due to the precise tolerances of diesel injection systems, it is extremely important that fuel be kept clean and free of dirt or water. Dirt or water in the system can cause severe damage to both the fuel pump and the fuel injectors. Fuel additives for lubricity are not recommended. There are numerous diesel fuel additives to help remove moisture from fuel, prevent microbe growth and to prevent gelling during cold weather. Before adding any type of fuel additive or extender, consult the Manufacturer's Owner's Manual.

Fuel Tank

The diesel fuel tank is made of aluminum. Pick-up and return lines are placed at opposite ends of the tank to inhibit fuel aeration. The engine pickup tube is cut at a 45° angle to allow optimum flow to the engine. The generator and Aqua-Hot intake tubes are set to approximately ¼ of a tank. This will prevent depleting the fuel supply while dry camping.

The bottom of the tank is made in a “V” configuration allowing the engine pick-up tube access to almost all available fuel in the tank. Internal baffles slow fuel slosh. A check valve placed at the bottom of the baffle, at the end of the tank with the pick-up tube, prevents fuel starvation through long corners when fuel supply is low.

NOTE:

Fill the fuel tank if the motorhome is going to be stored for any length of time to reduce the amount of potential condensation. After storage, check the vent tube for blockage. It is not uncommon for insects to plug the vent tube. If pressure or vacuum exists when the fuel cap is removed, the vent tube may be blocked. The end of the vent tube is located on the curbside of the fuel tank, near the bottom.

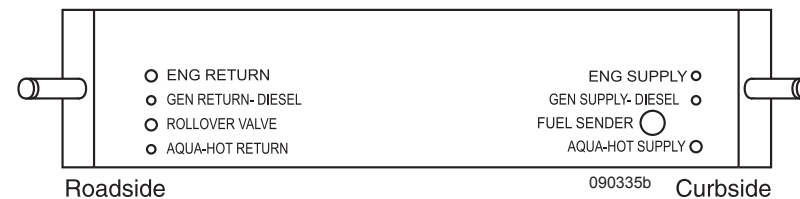

Fuel Sender

The Centroid fuel sender has no moving parts and works by measuring electrical property between inner and outer tubes in the tank. The more fuel between the tubes the higher the reading. Electronics in the head of the sender convert the capacitance to current to drive the fuel gauge.

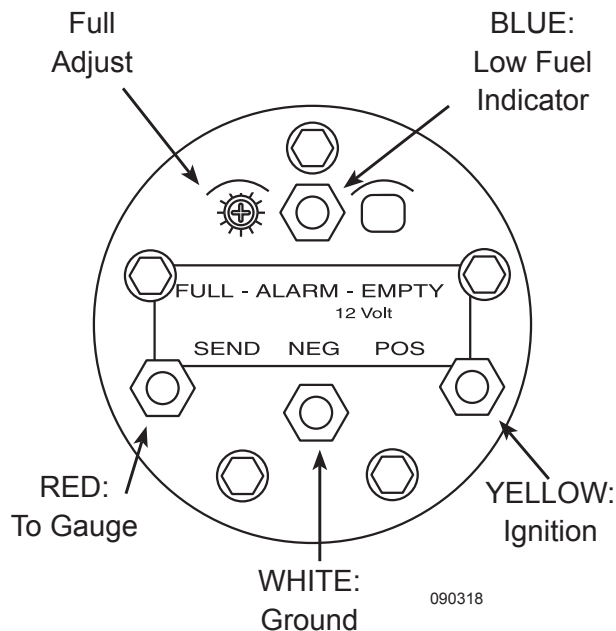

Connections:

The Centroid sender has four connections:

1 and 2 - Positive (POS) and Negative (NEG): Battery voltage to run the electronics in the sender head.

3 - SEND: Connects to the SEND terminal of the gauge on the dash.

4 - ALARM: Makes a connection internally to the negative (NEG) terminal when the low fuel alarm level is reached (when the fuel gauge is reading about 1/8 tank). This turns on the fuel indicator on the liquid crystal display on the speedometer and is not adjustable.

Adjustments:

The Centroid sender has two adjustments:

1 - EMPTY: Adjusts for length of sender.

It is set at the factory, covered with a sealant and should not be changed.

2 - FULL (Full Adjustment): The full adjustment can be used to correct for slight differences between fuel meters. During installation it was factory calibrated and does not need re-adjustment.

The correct adjustment technique, with a full tank of fuel, is to start with the full adjustment screw completely clockwise. This should cause the reading to be above full. Adjust slowly, rotate counterclockwise, until the full mark on the gauge is reached. The intent is to always adjust downscale rather than upscale.

Troubleshooting:

A. Electronic Output: The sender has a transistorized output to prevent an ohmmeter from getting a correct reading of output resistance.

B. Fuel Only: The sender will not work correctly in conducting fluids such as water (it will read above full all the time in water). One possibility is that when there is a constant above-full reading there may be water in the bottom of the fuel tank.

C. Contact Centroid: Probably 90% of the return Centroid tests work okay on the bench. If you have incorrect readings contact Centroid (telephone: 800-423-3574, or preferably, fax: 386-423-3709) with the symptoms. A short, "fill in the blanks" troubleshooting test is provided to test the sender. It is easier to find the problem that way than after the sender has been removed from the system, since the problem is not necessarily with the sender.

Fuel Lines & Hoses

Make a visual check for fuel leaks at all engine-mounted fuel lines, connections and at the fuel tank pick-up and return lines. Leaks in this area may best be detected by checking for accumulation of fuel under the tank. Engine performance and auxiliary equipment is dependent upon the ability of flexible hoses to transfer lubricating oil, air, coolant and fuel. Maintenance of hoses is an important step in ensuring efficient, economical and safe operation of the engine and related equipment.

INSPECTION:

Check hoses for leaks daily as part of the pre-start inspection. Check all fittings, clamps and ties. Ensure the hoses are not touching shafts, couplings or heated surfaces, including exhaust manifolds, sharp edges or other obvious hazardous areas. Vibration from the engine and road can move or fatigue clamps and ties. To ensure continued proper support, inspect fasteners frequently and tighten or replace them as necessary.

Fuel Filters

Two filters are used for the engine: a primary and secondary filter. The primary filter is located in the engine compartment. The secondary filter is located on the engine.

NOTE:

It is recommended to wear gloves and old clothing when working with diesel fuel. Avoid getting fuel in the interior of the motorhome.

Filter Maintenance Intervals:

- ◆ Change the primary fuel/water separator filter every six months or every 15,000 miles or at the first indication of power loss.
- ◆ Refer to the engine OEM manual for service intervals of the secondary fuel filter.
- ◆ The collection bowl on the primary filter should be inspected daily and drained when needed.

Reusable Collection Bowl:

A see-through collection bowl is used that won't discolor from alcohol, additives, or UV light and has a leak-proof, positive seal drain for easy service. Water and contaminant levels are visible at a glance.

Water in Fuel Light:

If the **Water in Fuel** light illuminates on the dash, the primary filter has detected water in the fuel. **DO NOT** continue engine operation as fuel contaminated with water can damage fuel injectors. Water, being heavier than fuel, will collect in the primary filter bowl. Drain primary filter bowl using the valve on the bottom of the filter bowl.

To drain water from the filter:

- ◆ Turn the valve on the bottom of the clear plastic filter bowl counterclockwise and let contaminant drain into a suitable container.
- ◆ Close valve and properly dispose of drained fluid.

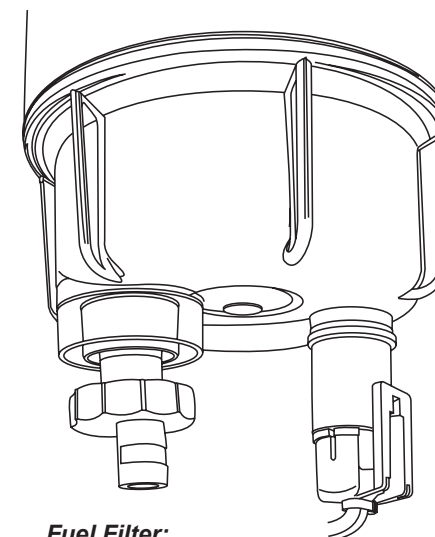

Fuel Filter:
Turn Valve counterclockwise to drain. 090481b

NOTE:

Always carry an extra filter as one tank full of excessively contaminated diesel fuel can plug a filter.

Changing the filter:

1. Wear safety goggles.
2. Drain the clear filter bowl. Spin the primary filter counterclockwise to remove it from head. Drain fuel from the filter into the container.
3. Remove the clear plastic bowl from the primary filter.
4. Apply motor oil or clean fuel to new O-rings. Install the clear plastic bowl on the new filter.
5. Fill the filter with fuel. Lube O-ring and outer gasket on the new filter with motor oil or clean fuel.

- Install the filter onto the housing.
Tighten an additional three-quarter to one full turn after the seat contacts the base.

NOTE:
Over tightening may result in damage to the unit.

NOTE:
The engine may run rough for a short period until all remaining air is forced through the fuel system.

CAUTION:
If ambient temperatures approach 0° F, Pennzoil Arctic Blue hydraulic fluid, or equivalent hydraulic fluid, should be used. Using incorrect hydraulic system fluid weights in cold temperatures will raise the hydraulic system operating pressure and may damage the hydraulic cooler.

Hydraulic Pump

The hydraulic pump creates pressure by meshing sets of gears together inside a close tolerance housing. A filtered supply of hydraulic fluid from the hydraulic reservoir enters the intake side of the pump. The meshing gear assembly “squeezes” the oil through the pump to the output side delivering the pressurized fluid to the power steering gear and the switching valve of the engine cooling system. Each half of the pump is equipped with an internal by-pass pressure relief spring. If the hydraulic pressure should exceed the specified pressure limit, the internal by-pass relief valve will be forced open to keep the hydraulic fluid at operating pressure. The hydraulic pressure generally is not rated in psi but is rated in the term Bar. One bar is equivalent to approximately 14.5 psi. Hydraulic system pressures with a system at no load may be as low as eight bars on the output side of the pump. This is due to the hydraulic fluid flow of the pump. When a load is placed on

the hydraulic pump, such as turning the steering wheel, hydraulic fluid flow slows from hydraulic fluid restriction and pressure increases.

This may be understood as a faucet with a garden hose attached. Crimping the hose with the faucet on will create pressure from the restriction. This principle applies to the hydraulic system. The hydraulic pump is the supply, the load would be the power steering gear or the hydraulic fan motors. Hydraulic system pressure at full load can exceed 130 bar or 2000 psi. Hydraulic system pressure falls dramatically after the load. The return line pressure may be as low as six to eight bars. The fluid enters the hydraulic cooler where the heat is dissipated.

Hydraulic Pump (Optional Series 60 & ISX):

The hydraulic pump is driven by a separate gear assembly mounted to the transmission called a PTO (power take-off). The intermediate shaft and coupling between the PTO and the hydraulic pump are lubricated by transmission fluid. No maintenance is required.

Hydraulic Cooler

The hydraulic cooler operates to prevent hydraulic fluid from overheating. When a load is placed on the hydraulic system, heat is created in the fluid. Heat must be dissipated to prevent the hydraulic fluid from overheating and breaking down. After cooling, the fluid is filtered before returning to the reservoir.

HYDRAULIC SYSTEM

The motorhome uses an engine driven hydraulic pump to operate both the power steering and engine hydraulic cooling fan systems, sharing one common reservoir. The hydraulic fluid used is Texaco Rando HD46 which has a wide ambient temperature operating range.

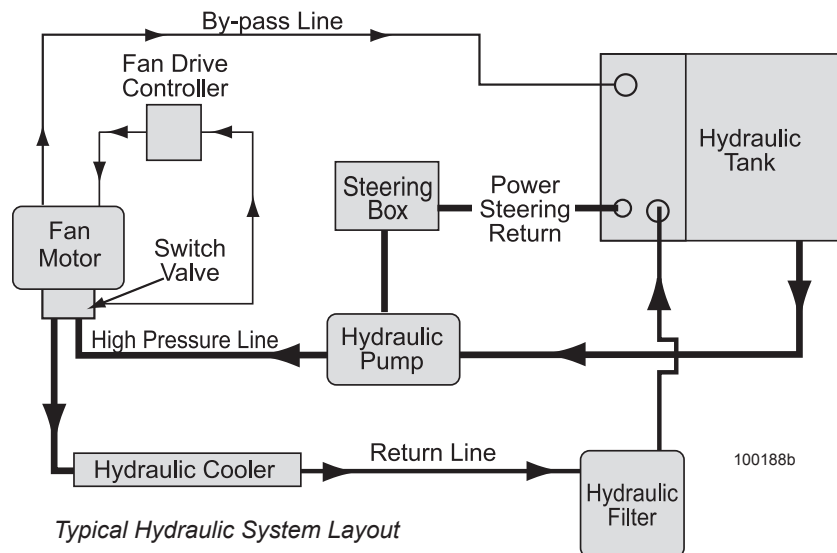

Care must be used when starting an engine in very cold climates. As with any oil, lower temperatures thicken the oil. Hydraulic system pressure increases due to the viscosity of the fluid. Although the hydraulic pump is equipped with pressure relief valves, the thick oil on the return line can exceed the operating pressure of the hydraulic cooler.

Hydraulic Fan System

The hydraulic fan drive system cools the radiator, charge air cooler, hydraulic fluid cooler and transmission cooler. The components of the hydraulic fan system are: hydraulic reservoir, filter, pump, hydraulic fan motor, hydraulic switching valve and fan drive controller. Cooling fan speed is proportional to engine speed and coolant temperature. When coolant temperature rises above 185° F, the fan drive controller slowly closes off the bypassing hydraulic fluid from the switching valve. As coolant temperature rises, a spool valve begins to move in the switching valve.

The spool valve directs the pressurized hydraulic fluid to the fan motor. The higher the coolant temperature, the further the spool valve is moved in the switching valve, providing a higher volume of pressurized hydraulic fluid to the fan motor. Fan motor speed is increased to meet the demand for cooling. The action of the fan drive controller is designed to move the spool in the switching valve to ramp up fan motor speed. This design saves horsepower and increases fuel mileage by precise control of hydraulic fan motor speed. The fan motor will increase in speed when the motorhome

is ascending long hills or operating in high ambient temperatures. It is normal for the fan to “roar” when it is operating. Fan motor speed and engine RPM are approximately the same with the switching valve in the full open position.

Therموالve (ISM & Series 60 Engines)

The wax filled therموالve, mounted at the top of the radiator, controls the action of the switching valve. When the radiator is cool, hydraulic fluid is allowed to flow through the inlet and outlet ports of the therموالve and return to the hydraulic reservoir. As

coolant temperature inside the radiator rises to approximately 185° F, wax inside the therموالve begins to melt and expand, which restricts hydraulic fluid flow through the therموالve. The restricted hydraulic fluid pressure then begins to move the internal spool valve of the switching valve. This process will continue until coolant temperature inside the radiator reaches approximately 199° F. At this temperature, hydraulic fluid flow through the therموالve is stopped, moving the spool valve to the full open position.

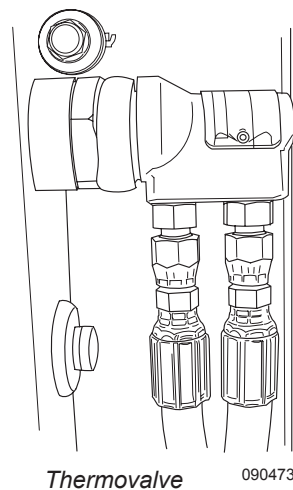

Electric Therموالve (ISX Engine)

The ISX engine uses an electric therموالve to monitor two thermal sensors. One sensor is located in the charge air pipe between the charge air cooler and intake manifold. If the intake air charge temperature becomes too high, the hydraulic fan will engage to cool the charge air cooler. The other temperature sensor monitors engine coolant. As coolant temperature increases, hydraulic fan speed will commensurate with engine temperature. This method will use engine power sparingly to operate the fan and keep the engine at the correct operating temperature.

Switching Valve

The switching valve is mounted to the fan motor and controls direction of high pressure hydraulic fluid flow. High pressure hydraulic fluid comes from the hydraulic pump to the switching valve before returning to the reservoir. Either the therموالve or the electric override valve directs the fluid to the spool in the switching valve. When the radiator is cool, pressurized hydraulic fluid will bypass the fan motor and return to the fluid reservoir. As radiator temperature rises, the therموالve signal is slowed or stopped to the switching valve. High pressure fluid is then directed to the fan motor, cooling the radiator.

Electric Override (ISM only)

Motorhomes are equipped with an electric override hydraulic control valve, located at the lower rear corner of the radiator package. This valve is normally closed and is plumbed parallel with the thermo valve and performs the same hydraulic signal function as the thermo valve, but electrically controlled by the engine computer.

The engine computer monitors intake manifold temperature. The electronics of the engine control a relay located in the rear run box. When intake manifold operating temperature is normal, the electronic engine will energize the coil of the relay. This energizes the coil of the override valve and the hydraulic fluid signal flows through the override valve to the thermo valve. If the engine electronics detect an over temperature condition of the intake manifold, the coil of the 87a relay is deactivated. Power to the override valve is removed, hydraulic fluid flow signal is stopped and internal spool of the switching valve moves to full open position. The high pressure fluid is directed to fan motor cooling the radiator.

Fan Motor

The fan motor is driven by hydraulic fluid pressure from the switching valve. The fan motor works on the same mechanical principle as a hydraulic pump, only in reverse. Instead of creating hydraulic pressure by meshing gears together in a close tolerance housing, the fan motor receives hydraulic pressure. The hydraulic fluid drives the fan motor's internal gear assembly, spinning the fan motor and attached fan blades.

The switching valve is mounted to the fan motor. The hydraulic fluid is then cooled and filtered before returning to the reservoir.

Hydraulic Filter

The hydraulic system filter, located in the engine compartment, has special features to protect the precision tolerance hydraulic components. A specially designed media filter absorbs harmful contaminants such as moisture and dirt.

The filter head is equipped with a built in bypass valve to prevent a clogged filter from developing a leak due to excess hydraulic fluid pressure inside a clogged filter. The filter is rated at ten micron*. This will ensure the hydraulic fluid is properly filtered.

***One micron is one millionth of one meter.**

Hydraulic Reservoir

The hydraulic reservoir, located in the engine compartment, is made from aluminum so the tank will not be affected by moisture that may condense. The oil level in the reservoir should be checked when the hydraulic fluid is at operating temperature. This should be done every 6,000 miles or three months. The oil dipstick/oil fill is located on top of the reservoir. The oil level should be kept between the full and add marks on the dipstick. When performing

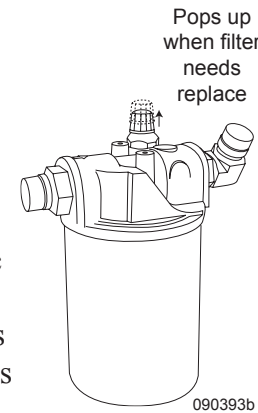

fluid level checks, inspect fittings and hoses for signs of leakage. Look underneath the motorhome for signs of fluid leakage. Avoid untimely and costly failures by having leaks repaired. Change the hydraulic oil filter every 15,000 miles or once a year.

NOTE:

The reservoir is filled with Texaco Rando HD46 from the factory.

AIR FILTER Changing the Filter

The entire air filter cartridge is discarded and replaced by loosening the inlet and outlet ducting clamps and releasing the retaining band snaps. The air filter is located in the engine compartment. The Air Filter Minder will indicate when the filter will need to be changed.

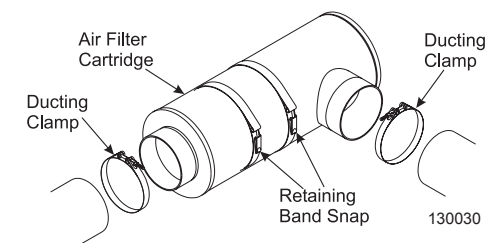

Air Filter Minder

The air filter minder, located in the roadside of the engine compartment, is a precision overflow restriction gauge designed to take the guesswork out of air cleaner replacement.

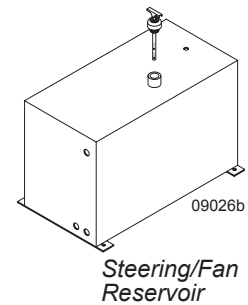

As dirt captured by filter cartridge slowly builds up, vacuum between the filter and charge air cooler increases. The indicator locks at the point of maximum restriction so readings can be taken with or without the engine running.

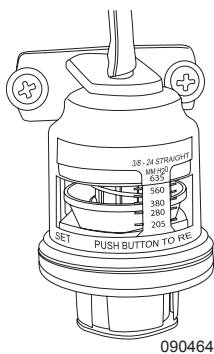

When the desired change-out point is reached, the air filter should be replaced and the service indicator reset by pushing the **Reset** button on the bottom of the minder.

EGR FILTER (DETROIT ONLY)

The EGR (Exhaust Gas Recirculation) filter is used to remove oil from the air supply for the EGR valve system. Oil in pneumatic valves can cause the valves to operate sluggishly, or not at all. Removing oil from the air supply for the EGR system helps to ensure longevity of the valves. **Drain the filter monthly and replace filter annually.** When performing maintenance, properly dispose of drainage and filters.

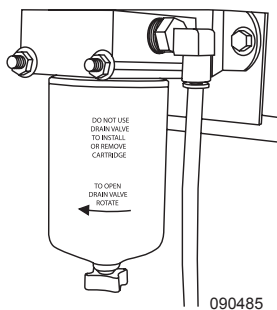

CAUTION:
Discharge air system before removing filter.

LUBRICATION MAINTENANCE

Performing regular scheduled maintenance ensures reliable operation and optimum service life of the various chassis components. Completed maintenance brings peace of mind knowing the various components have received proper service. Failure to follow maintenance guidelines, or perform scheduled maintenance, results in inefficient operation, premature component wear or component failure resulting in breakdown.

Maintenance schedules are usually performed at certain mile or time intervals. When performing high level procedures, lower level service should also be performed.

NOTE:
Maintenance schedules are based on normal operating conditions and use. Operating under unusual or adverse condition shortens service intervals.

NOTE:
Engine and transmission service intervals are listed in their respective manuals.

Proper Lubricant Waste Disposal:

When performing service maintenance on the engine, transmission or rear axle, waste fluids and filters should be properly disposed of or recycled. Package used oils, antifreeze and other fluids in sealed containers. In many cases used oil is accepted free of charge at county disposal sites. Waste fluids are toxic to pets and other animals. Waste fluids should not be left in open containers. The sweet odor of antifreeze is attractive to pets, but highly toxic.

CAUTION:
Properly dispose of used antifreeze and waste oil. Animals like the sweet odor of antifreeze and may ingest it if left in open containers. Wipe up any fluid spills. Pets may lie in puddles of fluid, many of which are irritants and can cause severe chemical burns if not properly washed.

Lubricant Classification:

Lubricants are manufactured in many forms for a variety of applications. There are many different oil and grease consistencies, each with a designed application. To properly select a particular type of lubricant for a specific application, the component must be evaluated. Component stress loads, ambient temperature, working temperature and environmental exposure are just a few of the variables to consider. Select the proper lubricant for its intended application. As an example: selecting high viscosity grease to lubricate a lock cylinder results in sluggish lock cylinder operation especially in a cool environment. Conversely, using graphite to lubricate a component that is under extreme temperature and load will result in component failure.

Grease ratings and their base compounds are especially important when selecting a lubricant type for an intended application. Some grease compounds are manufactured for multi-use application. These are acceptable if the grease rating is in accordance with the manufacturer's recommended lubricant type and rating.

Lubricants:

Many chassis components require lubrication. The types of lubricants used will vary with the application of the component. A component may fail prematurely due to lack of lubrication or from using an incorrect lubricant type. The component manufacturer usually recommends a particular type of lubricant with a minimum approval rating. Most lubricants are tested under strict guidelines set by the **ASTM (American Society for Testing and Materials)**. The **NLGI (National Lubricating Grease Institute)** helps disperse information to the grease production industry. Grease containers usually have an approval rating by the **SAE (Society of Automotive Engineers)**, **Mil Spec (Military Specification)**, **API (American Petroleum Institute)** or by other recognized and accepted organizations. The correct lubricant type with an approved specific rating must be used whenever applying, changing or adding any lubricant. When purchasing lubricants for a specific application be sure the label affirms the type of lubricant required with the tested rating by the term “meets or exceeds” in accordance with the manufacturer specifications.

Lubricating greases are made from different base compounds giving the grease different lubricating consistencies, properties and maximum operating temperatures. Most containers list the base compound and maximum operating temperature usually listed as melting point or drip point. Lubricating components, such as brake component for example, require a high temperature special base compound grease. Lubricating this type of component with other than specified grease type will result in inadequate lubricating qualities and component malfunction or failure.

INSPECTION:

When performing any scheduled maintenance, inspect the area around where you are working. For example, changing the oil, look at the rear differential. Inspect for visual signs of fluid leaks.

Most fluids and lubricants have a distinct odor, which can be used to detect early signs of trouble. Generally, odors are most detectable soon after parking. Unusual sounds are another method of detecting a problem early. There are many types of sounds that are normal, such as the cyclic purging of the air dryer. Become familiar with the different sounds. If something sounds odd, smells peculiar or looks unusual, investigate the situation.

Greasing:

Thoroughly clean all Zerk grease fittings before applying new lubricant. Keep paper towels or disposable rags handy when greasing. When lubricating items such as drive shafts and steer axle components, continued grease application is generally required until new grease appears at exit points.

Some items use sealed boots around the component to prevent moisture intrusion. When greasing these types of components, care must be given to prevent excess lubricant pressure from rupturing the seal.

WARNING:

Always chock wheels before going underneath the motorhome.

WARNING:

Never place yourself under motorhome without first properly blocking frame (jackstands) from coming down in case of rapid deflation of air system.

Brake actuating components require lubrication to keep the actuating components freely operating. Avoid contaminating brake linings with lubricant. Particular care and attention to details should be taken when lubricating brake actuating components. Wheel removal may be necessary to gain access the grease fittings.

NOTE:

Suspension, steering, brake and drivetrain components are lubricated at factory using Texaco Starplex NLGI 2 Lithium Soap based grease.

To apply grease:

- ◆ Clean the grease fitting. Initially operate grease gun until new lubricant discharges from nozzle, then wipe nozzle clean to avoid introducing contaminants into the component.
- ◆ Snap nozzle onto grease fitting. Nozzle must remain in line with the grease fitting during the application process. If the nozzle is not in line, lubricant will collect around nozzle and grease fitting, failing to lubricate the component.
- ◆ Wrap the nozzle with a paper towel or rag to prevent contamination and accidental soiling of other areas.

If the component does not accept grease the Zerk fitting may be plugged or damaged. Zerk fittings are replaceable and generally available at most auto supply stores. Zerk fittings come in a variety of angles depending on the application. Every effort should be made to lubricate the component, as neglect will only result in premature component failure.

NOTE:

Some grease fittings may not be accessible until the steering wheel is turned or the motorhome is moved slightly.

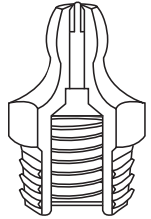

Typical Zerk Fitting

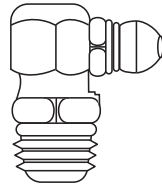
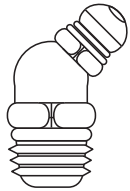

090368

LUBRICATION CHARTS
Cummins ISM

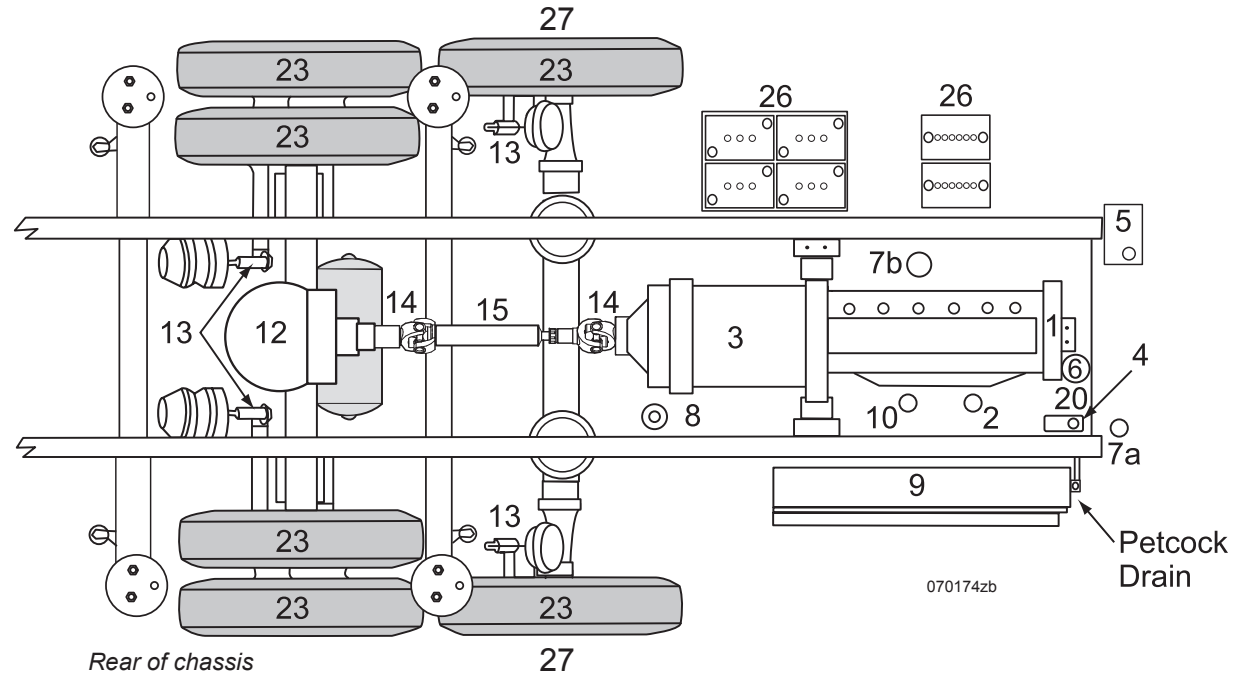
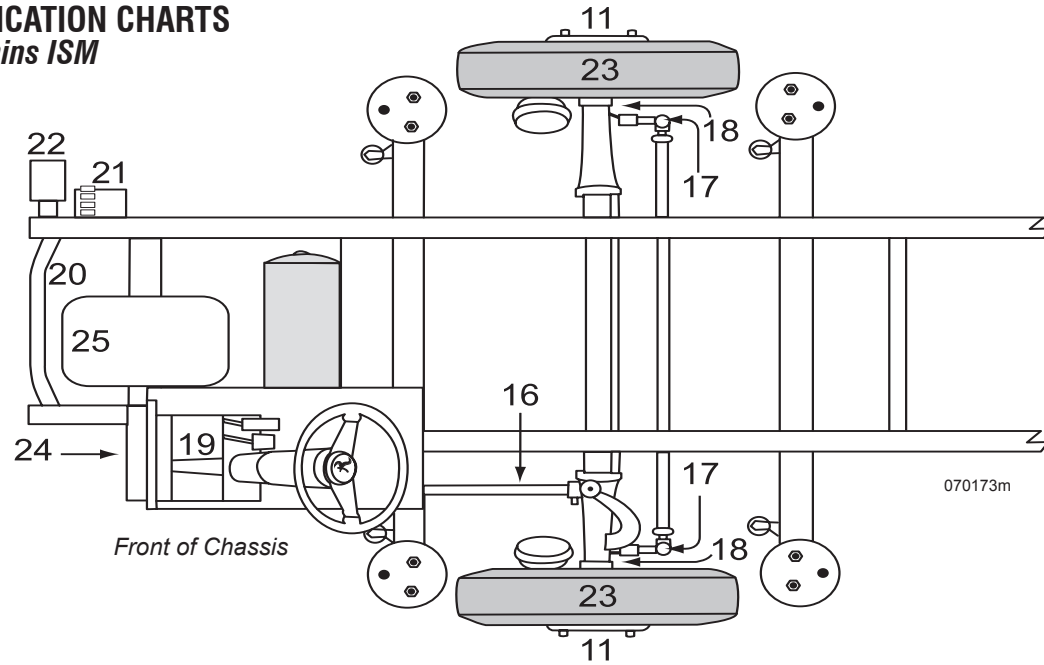

Component:		Action:	When:	
1.	Engine Oil Fill/Dipstick	Keep to Full Mark	Before Each Trip + Daily En route	EO
2.	Engine Oil Filter	Replace	At Oil Change	OEM
3.	Transmission	Keep to Full Mark	Refer to OEM Manual	TS
4.	Engine Coolant Reservoir	Level between Add and Full	Refer to OEM Manual	AF
5.	Hydraulic Fluid Reservoir	Keep to Full Mark	Monthly	HF
6.	Hydraulic Filter	Replace	15,000 or Annually	HF
7a.	Filter Fuel/Water Separator (Primary)	Replace	15,000 or 6 Months	FF
7b.	Filter Fuel (Secondary)	Replace	Refer to OEM Manual	OEM
8.	Air Dryer Filter	Replace	2 -3 Years	-
9.	Radiator/Charge Air Cooler	Inspect	Weekly	-
10.	Coolant Filter	Replace	Refer to OEM Manual	OEM
11.	Wheel Bearings	Re-pack	30,000 or Annually	HT
12.	Rear Differential	To Filler Plug	250,000 or 3 Years	GO
13.	Slack Adjusters/S-Cams	Grease-3 Fittings ea.	10,000 or 6 Months	CL
14.	Drive Shaft Universal Joints	Grease-2 Fittings	5,000 or 6 Months	CL
15.	Drive Shaft Slip Yoke	Grease-1 Fitting	5,000 or 6 Months	CL
16.	Drag Link	Grease-2 Fittings	5,000 or 6 Months	CL
17.	Center Link	Grease-2 Fittings	5,000 or 6 Months	CL
18.	Spindles/Kingpins	Grease-2 Fittings ea.	5,000 or 6 Months	CL
19.	Steering Intermediate Shaft	Grease-3 Fittings	30,000 or Annually	CL
20.	Air Tank Drains	Drains	Monthly	-
21.	Slide Room Reservoir	Keep to Full Mark	6,000 or 3 Months	HF
22.	Hydraulic Jack Reservoir	Keep to Full Mark	6,000 or 3 Months	HF
23.	Tire Pressure	Check	Before Each Trip + Daily En route	-
24.	Steering Box	Grease-1 Fitting	Twice a Year	CL
25.	Generator	Refer to Service Manual	Refer to OEM Manual	OEM
26.	Batteries	Inspect	Every 2 Weeks	DW
	Batteries	Apply Coating	10,000 or Quarterly	P
27.	Tag Axle - Oil Bath Hubs	Keep to Full Mark	Before Each Trip + Daily En route	GO

Lubrication Code Chart:	
EO	Engine oil as recommended by engine manufacturer.
OEM	Refer to the Original Equipment Manufacturer's manual.
GO	Texaco Star Gear Lubricant SAE 80w-90
CL	Chassis lubricant should be a high quality non corrosive multi-purpose lithium soap base lubricant that is water resistant and designed to withstand extremely high operating temperatures.
AF	Antifreeze as recommended by engine manufacturer.
BF	Dot-3 Brake Fluid
FF	Fuel Filter
HT	High Temperature Bearing Grease
TS	TranSynd™
DW	Distilled Water
P	Petroleum Jelly
HF	Texaco Rando HD 46

NOTE:

Service must be performed every twelve (12) months, regardless of actual mileage, to protect seals, bearings and gaskets from drying out and failing. The motorhome must be started and driven for at least 20 miles every two weeks. It is important to remember the generator maintenance interval is based on hours of usage. Consult the OEM Owner's Manual for the generator service interval.

Cummins ISX (Optional)

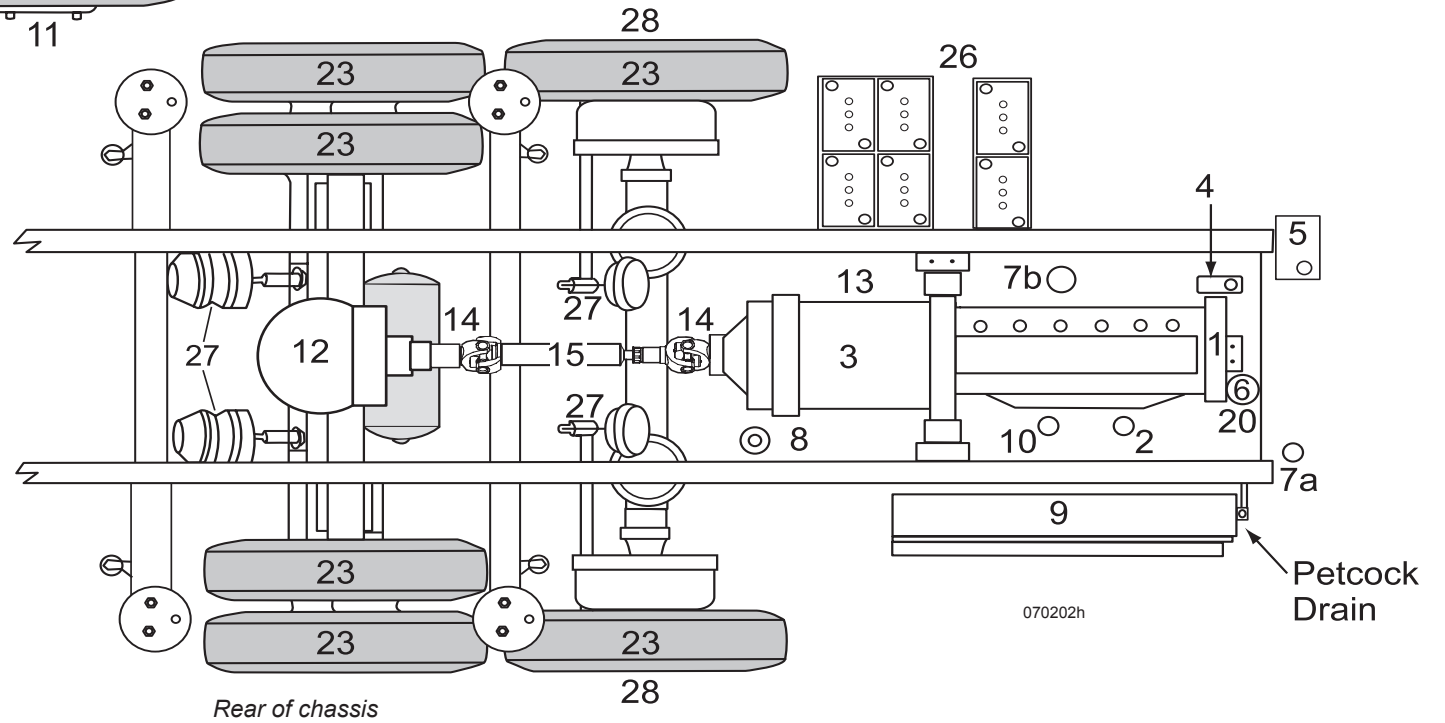
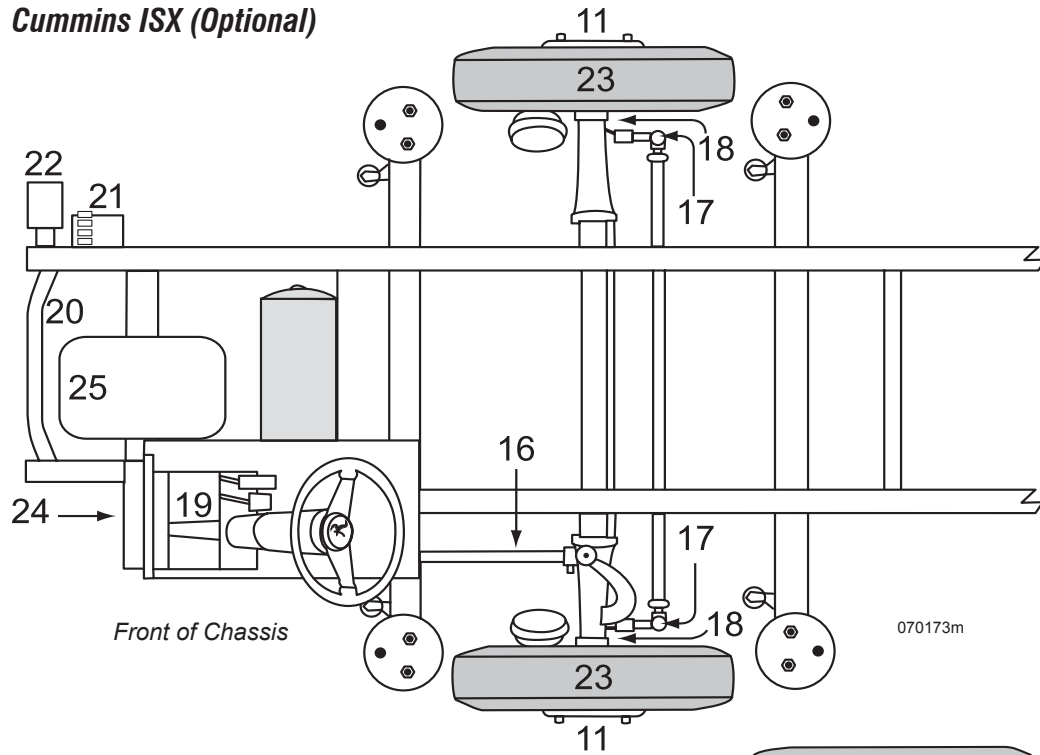

Component:		Action:	When:	Code
1.	Engine Oil Fill	Keep to Full Mark	Before Each Trip + Daily En route	EO
2.	Engine Oil Filter	Replace	At Oil Change	OEM
3.	Transmission	Keep to Full Mark	Refer to OEM Manual	TS
4.	Engine Coolant Reservoir	Level between Add and Full	Refer to OEM Manual	AF
5.	Hydraulic Fluid Reservoir	Keep to Full Mark	Monthly	HF
6.	Hydraulic Filter	Replace	15,000 or Annually	HF
7a.	Filter Fuel/Water Separator (Primary)	Replace	15,000 or 6 Months	FF
7b.	Filter Fuel (Secondary)	Replace	Refer to OEM Manual	OEM
8.	Air Dryer Filter	Replace	2 -3 Years	-
9.	Radiator/Charge Air Cooler	Inspect	Weekly	-
10.	Coolant Filter	Replace	Refer to OEM Manual	OEM
11.	Wheel Bearings	Re-pack	30,000 or Annually	HT
12.	Rear Differential	To Filler Plug	250,000 or 3 Years	GO
13.	PTO	Inspect Fittings	Monthly	-
14.	Drive Shaft Universal Joints	Grease-2 Fittings	5,000 or 6 months	CL
15.	Drive Shaft Slip Yoke	Grease-1 Fitting	5,000 or 6 Months	CL
16.	Drag Link	Grease-2 Fitting	5,000 or 6 Months	CL
17.	Center Link	Grease-2 Fittings	5,000 or 6 Months	CL
18.	Spindles/Kingpins	Grease-2 Fittings ea.	5,000 or 6 Months	CL
19.	Intermediate Steering Shaft	Grease-3 Fittings	30,000 or Annually	CL
20.	Air Tank Drains	Drains	Monthly	-
21.	Slide Room Reservoir	Keep to Full Mark	6,000 or 3 Months	HF
22.	Hydraulic Jack Reservoir	Keep to Full Mark	6,000 or 3 Months	HF
23.	Tire Pressure	Check	Before Each Trip + Daily En route	-
24.	Steering Box	Grease-1 Fitting	Twice a Year	CL
25.	Generator	Refer to Service Manual	Refer to OEM Manual	OEM
26.	Batteries	Inspect/Apply	Every 2 Weeks/10,000	DW/P
27.	Slack Adjuster/S-Cam	Grease-3 Fittings ea.	10,000 or Quarterly	CL
28.	Tag Axle - Oil Bath Hubs	Keep to Full Mark	Before Each Trip + Daily En route	GO

Lubrication Code Chart:	
EO	Engine oil as recommended by engine manufacturer.
OEM	Refer to the Original Equipment Manufacturer's manual.
GO	Texaco Star Gear Lubricant SAE 80w-90
CL	Chassis lubricant should be a high quality non corrosive multi-purpose lithium soap base lubricant that is water resistant and designed to withstand extremely high operating temperatures.
AF	Antifreeze as recommended by engine manufacturer.
BF	Dot-3 Brake Fluid
FF	Fuel Filter
HT	High Temperature Bearing Grease
TS	TranSynd™
DW	Distilled Water
P	Petroleum Jelly
HF	Texaco Rando HD 46

NOTE:

Service must be performed every twelve (12) months, regardless of actual mileage, to protect seals, bearings and gaskets from drying out and failing. The motorhome must be started and driven for at least 20 miles every two weeks. It is important to remember the generator maintenance interval is based on hours of usage. Consult the OEM Owner's Manual for the generator service interval.

Detroit Diesel Series 60 (Optional)

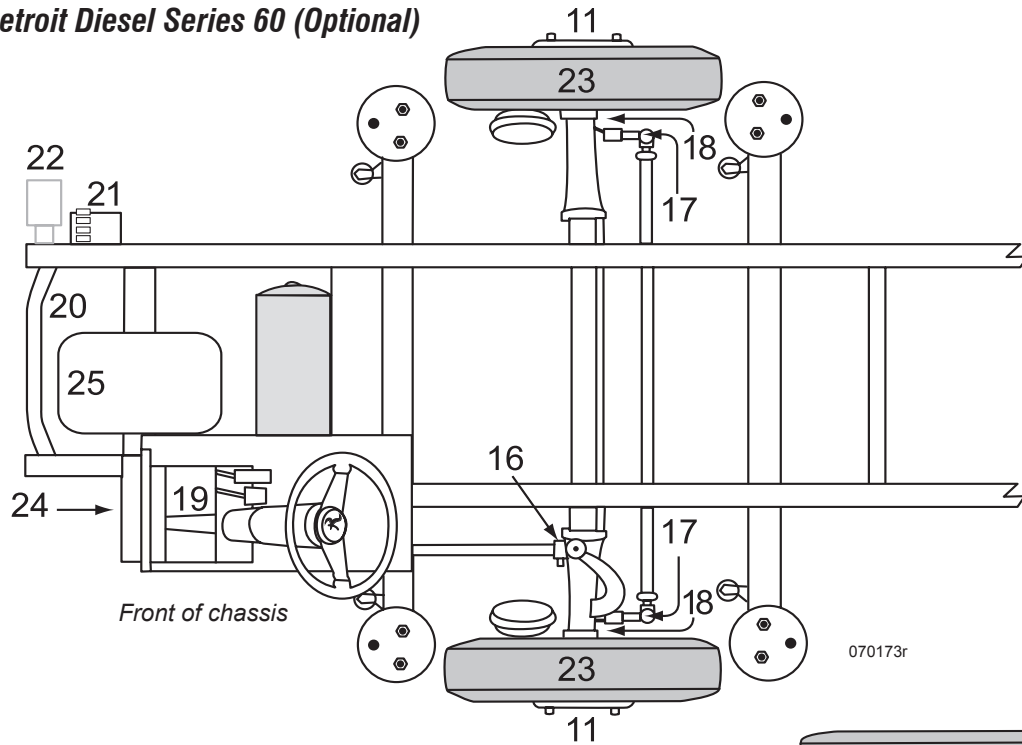

070173r

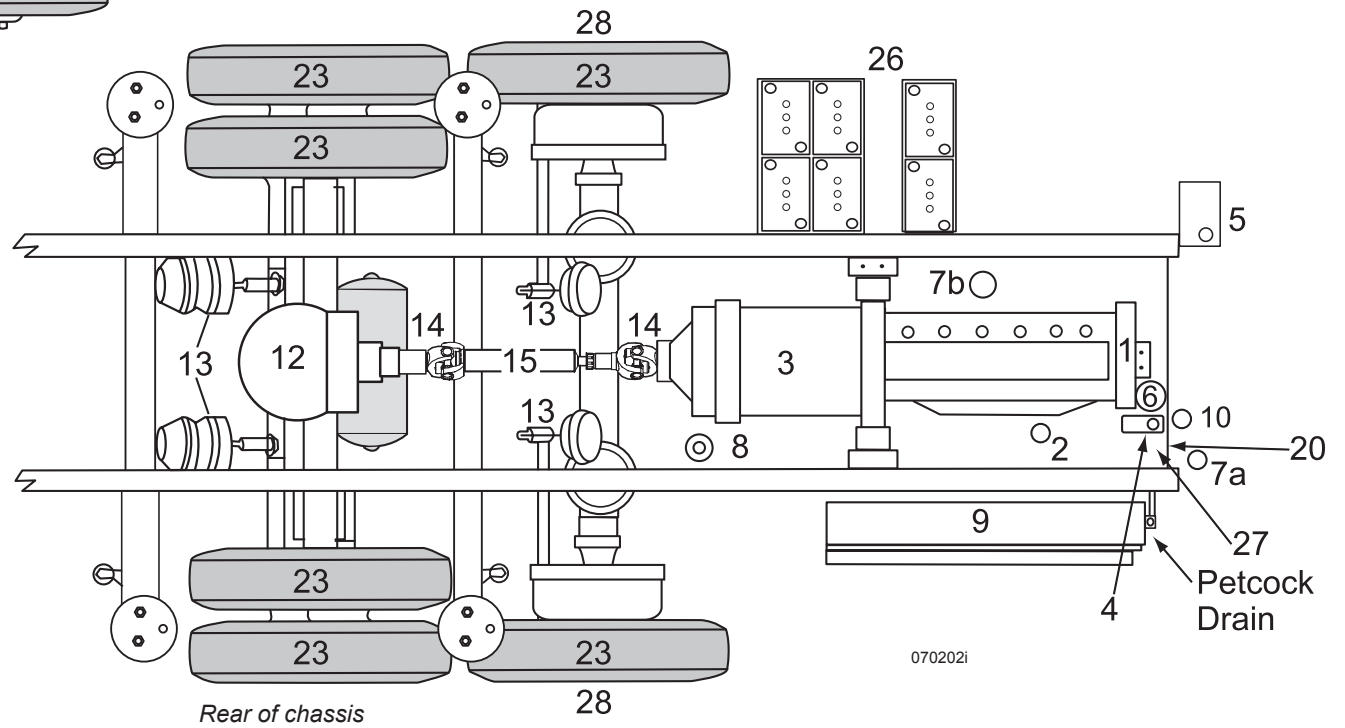

070202i

Component:		Action:	When:	Code
1.	Engine Oil Fill	Keep to Full Mark	Before Each Trip + Daily En route	EO
2.	Engine Oil Filter	Replace	At Oil Change	OEM
3.	Transmission	Keep to Full Mark	Refer to OEM Manual	TS
4.	Engine Coolant Reservoir	Level between Add and Full	Refer to OEM Manual	AF
5.	Hydraulic Fluid Reservoir	Keep to Full Mark	Monthly	HF
6.	Hydraulic Filter	Replace	15,000 or Annually	HF
7a.	Filter Fuel/Water Separator (Primary)	Replace	15,000 or 6 Months	FF
7b.	Filter Fuel (Secondary)	Replace	Refer to OEM Manual	OEM
8.	Air Dryer Filter	Replace	2 -3 Years	-
9.	Radiator/Charge Air Cooler	Inspect	Weekly	-
10.	Coolant Filter	Replace	Refer to OEM Manual	OEM
11.	Wheel Bearings	Re-pack	30,000 or Annually	HT
12.	Rear Differential	To Filler Plug	250,000 or 3 Years	GO
13.	Slack Adjusters/S-Cams	Grease-3 Fittings ea.	10,000 or 3 Months	CL
14.	Drive Shaft Universal Joints	Grease-2 Fittings	5,000 or 6 Months	CL
15.	Drive Shaft Slip Yoke	Grease-1 Fitting	5,000 or 6 Months	CL
16.	Drag Link	Grease-2 Fitting	5,000 or 6 Months	CL
17.	Center Link	Grease-2 Fittings	5,000 or 6 Months	CL
18.	Spindles/Kingpins	Grease-2 Fittings ea.	5,000 or 6 Months	CL
19.	Intermediate Steering Shaft	Grease-3 Fittings	30,000 or Annually	CL
20.	Air Tank Drains	Drains	Monthly	-
21.	Slide Room Reservoir	Keep to Full Mark	6,000 or 3 Months	HF
22.	Hydraulic Jack Reservoir	Keep to Full Mark	6,000 or 3 Months	HF
23.	Tire Pressure	Check	Before Each Trip + Daily En route	-
24.	Steering Box	Grease-1 Fitting	Twice a Year	CL
25.	Generator	Refer to Service Manual	Refer to OEM Manual	OEM
26.	Batteries	Inspect/Apply	Every 2 Weeks/10,000	DW/P
27.	EGR Filter	Drain/Replace	Monthly/Annually	OEM
28.	Tag Axle - Oil Bath Hubs	Keep to Full Mark	Before Each Trip + Daily En route	GO

Lubrication Code Chart:	
EO	Engine oil as recommended by engine manufacturer.
OEM	Refer to the Original Equipment Manufacturer's manual.
GO	Texaco Star Gear Lubricant SAE 80w-90
CL	Chassis lubricant should be a high quality non corrosive multi-purpose lithium soap base lubricant that is water resistant and designed to withstand extremely high operating temperatures.
AF	Antifreeze as recommended by engine manufacturer.
BF	Dot-3 Brake Fluid
FF	Fuel Filter
HT	High Temperature Bearing Grease
TS	TranSynd™
DW	Distilled Water
P	Petroleum Jelly
HF	Texaco Rando HD 46

NOTE:

Service must be performed every twelve (12) months, regardless of actual mileage, to protect seals, bearings and gaskets from drying out and failing. The motorhome must be started and driven for at least 20 miles every two weeks. It is important to remember the generator maintenance interval is based on hours of usage. Consult the OEM Owner's Manual for the generator service interval.

ENGINE DRIVE BELT DIAGRAM

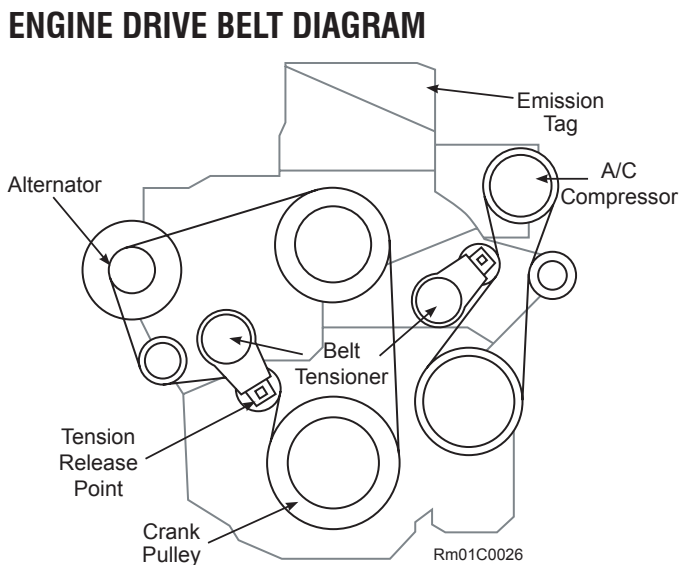

ISM 02
CUMMINS DIESEL

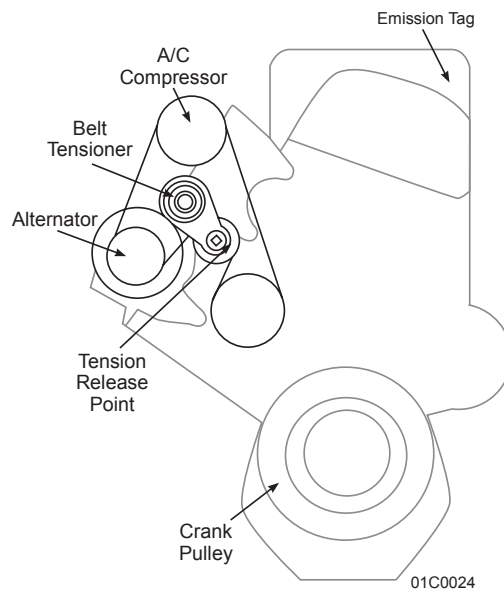

Series 60
DETROIT MOTOR

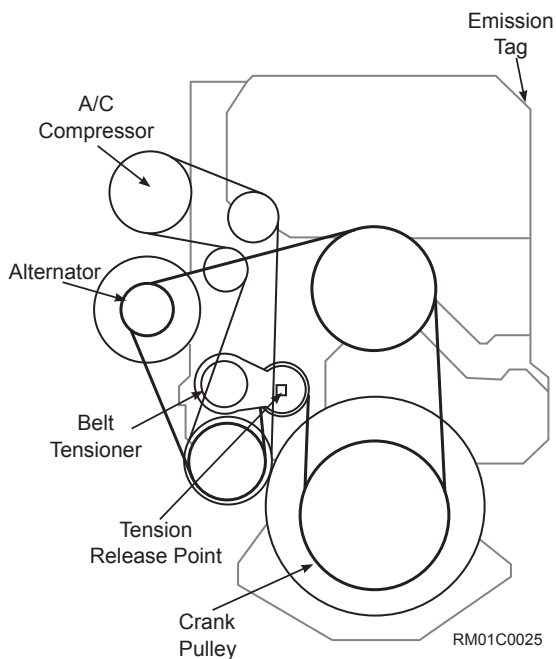

ISX
CUMMINS DIESEL

SPECIFICATIONS CHARTS

Tank Capacities

Tank Capacities (Approx. Gallons) All Models	
Water Heater	10 gallons
Grey Water	56 gallons
Black Water	56 gallons
Fresh Water	100 gallons
Diesel Fuel	150 gallons
LP-Gas*	25 gallons

*Actual filled LP-Gas Tank Capacity is 80% of listing due to safety shutoff required on tank.

NOTE:

All tank capacities are estimated based upon calculations provided by the tank manufacturers and represent approximate capacities. The actual “usable capacity” may be greater or less than the estimated capacities based upon fabrication and installation of the tanks.

NOTE:

This chart reflects product specifications available at the time of printing. Therefore any floor plans introduced thereafter may not be reflected in the chart. All other information contained throughout the manual will still apply.

Engine Specifications

ENGINE SPECIFICATIONS	ISM	ISX 525 HP	SERIES 60
Cubic Inch Displacement	11 L/661 CI	15 L/915 CI	14.0 L/858 CI
Engine HP	500 HP @ 1800 RPM	525 HP @ 1800 RPM	515 HP @ 1800 RPM
Engine Torque	1450 lbs./ft. @ 1200 RPM	1650 lbs./ft. @ 1200 RPM	1650 lbs./ft. @ 1200 RPM
Governed Speed	1800 RPM	2000 RPM	2100 RPM
Firing Order	153624	153624	153624
Rear Axle Ratio	4:30:1	4:30:1	4:30:1
Alternator Amp Size	270 Amp	270 Amp	270 Amp

Chassis Fluid Capacities

CHASSIS LIQUID CAPACITIES	ISM	ISX	SERIES 60
Engine Oil	38 Qts.	48 Qts.	40 Qts.
Transmission Oil (initial amount)	43 Qts.	43 Qts.	43 Qts.
Transmission Oil (with service)	34 Qts. w/filter	34 Qts. w/filter	34 Qts. w/filter
Radiator Coolant (initial amount)	50-55 Qts.	64 Qts.	50-55 Qts.
A/C Refrigerant (initial amount)	4 lbs. 134 A	4 lbs. 134 A	4 lbs. 134 A
Hydraulic Oil	50-55 Qts.	50-55 Qts.	50-55 Qts.
Rear End	15 Qts. Approx.	15 Qts. Approx.	15 Qts. Approx.

Generator Specifications

10 Kw

SERVICE INFORMATION

Refer to operator's manual for maintenance specifications and adjustments.

Air Cleaner	—	140-3071
Oil Filter	—	122-0897
Fuel Filter	—	149-2513
Oil Capacity	— 6	Qts w/oil filter
API Designation	— CE	
Temp	SAE Viscosity	
5° - 120°F	15W-40	
(-13°F) - 68°F	10W-30	
(-40°F) - 68°F	5W-30	

If service/parts are needed the Onan distributor can be located in the yellow pages under Generators-Electric. In the USA or Canada call 1-800-888-Onan DC Fuse & Radiator Cap Under Cover.



Generator Specifications Label.
42' and above

060144p

Belts & Filters

CUMMINS ENGINES			
Filter & Belt	Manufacturer	ISM Part #	ISX Part #
Coolant Filter	Fleetguard	WF 2071	WF 2126
Oil Filter	Fleetguard	WF 9001	WF 9001
Fuel Filter (Primary)	Parker	53230P	53230P
Fuel Filter (Secondary)	Fleetguard	FS 1000	FF 2200
Aqua-Hot Fuel Filter	Gar-ber	Model #R	Model #R
Hydraulic Filter	MP Filtri	CSG100P10A (10 micron)	CSG100P10A (10 micron)
Alternator Belt	Cummins	3028521	3682893
A/C Belt	Dayco	3401283	3682687
Air Filter	Donaldson	P53744802 (MP 2329)	P53744802 (MP 2329)
Air Dryer Filter	Meritor Wabco	R950011	R950011
Transmission Filter	Allison	2952688	2952688
A/C Filter Drier	--	*MP 05400001	*MP 05400001

*MP= Manufacturer Part #.

DETROIT ENGINE		
Filter & Belt	Manufacturer	Series 60
Coolant Filter	Power Cool	WF 2071
Oil Filter	Power Guard	WF 9001
Fuel Filter (Primary)	Power Guard	200200 (25 micron)
Fuel Filter (Secondary)	Fleetguard	FS 1000
Aqua-Hot Fuel Filter	Gar-ber	Model #R
Hydraulic Filter	MP Filtri	CSG100P10A (10 micron)
Alternator Belt	Detroit Diesel	23520613
A/C Belt	Detroit Diesel	23520613
Air Filter	Donaldson	P53744802 (MP 2329)
Air Dryer Filter	Meritor Wabco	R950011
Transmission Filter	Allison	29526889
A/C Filter Drier	--	*MP 05400001

NOTE:

Filter and belt numbers were correct at the time of printing. Verify the numbers at time of removal. The manufacturer will not be responsible for incorrect filter or belt usage. Please refer to the engine manufacturer's operating instructions for specific maintenance information.

BATTERY SPECIFICATION CHARTS

Application	AH (20 HR)	CCA†	RC (25A @ 80° F) Minutes
12 Volt Chassis* - MHD (2 each)	Group 31p	950	195
6 Volt Domestic** each)	U2200 (4	450	75 Amp @ 80° F = 230 Min.

*Batteries connected in parallel. **Four batteries connected in a Series/Parallel configuration. †CCA Ratings are 0° F. These are the minimum requirements.

Approximate Hours of Ampere Load					
**U2200	5 AMPS	10 AMPS	15 AMPS	20 AMPS	25 AMPS
	110	44	25	18	14

**Four batteries connected in a Series/Parallel configuration.

Battery State of Charge vs Voltage/Specific Gravity			
Voltage	Specific Gravity	State of Charge	Depth of Charge
12.65	1.265	100%	0%
12.45	1.225	75%	25%
12.25	1.190	60%	50%
12.05	1.145	25%	75%
11.90	1.100	0%	100%

Voltage Reading: Battery fully charged at rest for one hour.

Engine Cold Cranking Amp Requirements			
ISM	1800	CCA	12 VOLTS
ISX	1850	CCA	12 VOLTS
Series 60	1800	CCA	12 VOLTS

CCA Ratings are at 0° F. These are the minimum requirements.

MAINTENANCE RECORDS

After scheduled services are performed, record the date, odometer reading and who performed the service in the boxes provided after the maintenance interval. Any additional information from “Owner Checks and Services” or “Periodic Maintenance” can be added on the following record pages. **In addition, retain all maintenance receipts.** The owner information portfolio is a convenient place to store them.

LUBRICATION SERVICE RECORD

KEY TO SERVICES

- A – Lubrication & Inspection
- A1 – Motor Oil & Filter Change
- A2 – Transmission Oil Change

- A3 – Drive Axle Oil Change
- A4 – Wheel Bearing Service
- B – Prescribed Service

- C – Prescribed Service
- D – Prescribed Service
- E – Prescribed Service

MILEAGE	SERVICES										JOB PERFORMED	
	A	A1	A2	A3	A4	B	C	D	E	DATE	BY	
1												
2												
3												
4												
5												
6												
7												
8												
9												
10												
11												
12												
13												
14												
15												
16												
17												
18												
19												
20												
21												
22												
23												
24												
25												
26												

TECHNICAL PUBLICATIONS

Manager:

Vance Buell

OPERATIONS

Technical Writers

William Birch - OR

Nate Bondurant - OR

Tony Isom - OR

Thomas Joachim - IN

Creative Designers

Aaron Graham - OR

Kelly Stroble - OR

Julie Slagle - IN

ILLUSTRATIONS:

Kelly Stroble, Aaron Graham, Dustin Hutchcraft

PRINTING

TechnaPrint - OR

ONLINE

Corporate Site: www.monaco-online.com

ONLINE TOURS

www.monaco-online.com/tours/

Executive 2007 ~ Technical Writer Tony Isom

Executive 2007 ~ Layout Design & Cover Aaron Graham

THE EXECUTIVE 07

INDEX

A

ABS/ATC System (Anti-lock Brakes).....	223
Air Dryer.....	219
Desiccant Cartridge.....	220
Desiccant-Type Air Dryer.....	220
Air Dryer Cycle.....	221
Air Conditioning - Roof.....	104
Operations.....	104
Heat Pump Operation.....	105
Return Air filters.....	105
Air Filter.....	257
Changing the Filter.....	257
Air Filter Minder.....	257
Air Leveling.....	232
Automatic Air Leveling.....	233
Manual Air Leveling.....	233
Travel Mode.....	234
Air Mattress Bed (OPT).....	135
Troubleshooting.....	135
Air Spring Inspections.....	221
Air Supply System.....	216
Air Governor.....	217
Air Storage Tanks.....	217
Air Fittings.....	218
Air Coupler - Universal.....	218
Air System - Charging (External).....	219
Aladdin™ Engine Display.....	213
Aladdin™ System.....	138
Operations.....	139
Alternator.....	199
Alternator Testing Procedure.....	200
Aqua-Hot.....	106
Troubleshooting.....	107
Bay Thermostat.....	107
Care & Maintenance.....	107
Fuel Filter.....	109
Aqua-Hot Overview.....	110
Automatic Appliance Selector.....	101
Appliances - Introduction.....	92
Awnings.....	128
Slide-out Cover.....	128
Entry Door Awning - Girard Automatic (OPT).....	129
Window Awning (OPT).....	129
Patio Awning - Girard.....	129
Awning Care & Cleaning.....	131
Storm Precautions.....	131

B

Backing Up A Motorhome.....	27
Batteries - House.....	189
Battery Maintenance.....	190
Testing the Battery.....	191
Battery Charge Time & Consumption Rate.....	192
Battery - Chassis.....	196
Battery Cut-Off.....	179
Battery Disconnect - Chassis.....	196
Battery Disconnect - House.....	179
Battery Specification Charts.....	268
Maintenance Records.....	269
Blinds Cockpit (OPT).....	133
Brake - Auxiliary (Engine Brake).....	247
Brake Systems.....	222
Air Brakes.....	222
Park & Emergency Brake System.....	222
Brake Adjustment/Slack Adjuster.....	222
Brake Systems - Backup.....	223
Breaking Camp.....	31
Bulb Usage - Interior.....	194

C

Carbon Monoxide Detector.....	54
Operation.....	55
Alarm.....	55
Testing.....	56
Cleaning & Maintenance.....	56
Ceiling.....	78
Central Vacuum (OPT).....	118
Operation.....	118
Maintenance.....	118
Chassis - Introduction.....	216
Chassis Electrical - Introduction.....	196
Citizen Band (CB) Radio (OPT).....	137
Citizens Band (CB) Radio - Prep.....	137
Console.....	202
Transmission Shift Selector.....	202
Cooktop.....	102
Care & Cleaning.....	103
Coolant System.....	245
Radiator/Charge Air Cooler.....	246
Countertops.....	81
Solid Surface.....	81

D

Dash	204
Instrument Panel	204
Indicator Lights	206
Switches	207
Dash Air Conditioner & Heater Controls	209
Operating Tips & Hints	210
System Components	211
Troubleshooting	212
Diagnostic Plug Location	213
Dishwasher (OPT)	117
Distribution Panel - House 12 Volt DC .	188
Distribution Panels - House 120/240 Volt AC	187
Circuit Breaker	187
Door - Sliding	133
Drive Axle & Drive Shaft	229
Driving & Safety	18
Inspections	18
Familiarize Yourself	18
Mirror Adjust	18
Safety Seat Belts	18
Driving Tips	20
Drum Brake Lubrication	232
Dry Camping	30
Dryer (OPT)	115
Dryer Maintenance.....	116

E

EGR Filter (Detroit Only)	258
Electric Baseboard Heater (OPT)	110
Emergency Roadside Procedures	32
In Case of Flat Tire	33
Engine Light - Retractable	33
Dead Chassis Battery	33
Engine - General Information	240
Engine “No Start” - Flow Chart	214
Engine Diagram	240
Cummins - ISM - II Standard	240
Cummins ISX (OPT)	241
Detroit Diesel (OPT).....	241
Engine Drive Belt Diagram	266
Engine Oil	243
Engine Shutdown	244
Extended Engine Shutdown	245
Entry Door	123
Air Seal	123
Latch Adjustments	124
Screen Door	124
Entry Step	122
Operation.....	122
Stepwell.....	123
Equipment - Introduction	122
Escape (Egress) Window	57
Exterior Care	60
Corrosion.....	60
Washing.....	60
Drying	60
Waxing	60
Paint Codes	61
Tire Care	61
Wheels - Coated Aluminum.....	62
Bright Metal	62

Exterior Maintenance	62
Fiberglass	63
Roof Care & Seal Inspections.....	63
Sealant Types	63

F

Fabrics	65
General Care & Cleaning.....	65
Vinyl.....	65
Leather	67
Sensuede	67
Ultra-Leather.....	68
Fabric Cleaning Codes.....	68
Fabric Specifications Charts	70
Fans	132
Bathroom Fan.....	132
Exhaust Fan.....	132
Bedroom Ceiling Fan (OPT).....	133
Faucets	157
Fire Extinguisher	56
Floors	76
Carpet Cleaning	76
Tile Floor.....	77
Laminate Floor (OPT).....	78
Front Axle	225
Alignment	226
Lubrication Maintenance Safety	227
Steering Components	227
Steering Column	227
Drag Link.....	228
Center Link	228
Steering Spindles	228
Control Arm Bushings	228

Fuel System	252
Fuel Requirements	252
Fuel Tank.....	252
Fuel Sender	253
Fuel Lines & Hoses.....	254
Fuel Filters	254
Fuses	189
Fuses & Circuits	197
Rear Start Switches.....	197
Isolator Relay.....	198
Relays.....	198

G

Generator - 120/240 Volt AC	183
Pre-Start Checks.....	183
Starting the Generator	184
Stopping the Generator	184
Powering the Equipment.....	184
Generator Fuel	185
Resetting the Circuit Breaker.....	185
Generator Exercise.....	185
GFCI Breakers & Outlets	188
Glossary of Terms	5
GPS Navigation	138

H

Height Control Valves	221
Hitch	24
Using the Rear Receiver	24
House Electrical - Introduction	178

Hydraulic System	255
Hydraulic Pump	255
Hydraulic Cooler.....	255
Hydraulic Fan System.....	256
Therموالve (ISM & Series 60 Engines).....	256
Electric Therموالve (ISX Engine)	256
Switching Valve	256
Electric Override (ISM only).....	257
Fan Motor.....	257
Hydraulic Filter	257
Hydraulic Reservoir	257

I,J

Interior Care	65
Cockpit.....	65
Inverter	185
Providing AC Power with Inverter	185
Battery Charging with the Inverter	186
Auto Generator Start.....	186
Factory Default Settings	187
Battery Temperature Sensor.....	187

K

Keyless Entry	124
Operation.....	124

L

Ladder - Rear	137
Leveling - Air /Hydraulic (OPT)	234
Hydraulic Automatic Leveling.....	234
Hydraulic Manual Leveling	235
Leveling - Hydraulic (OPT)	236
Prior to Leveling	237
Manual Leveling	237
Automatic Leveling	238
Retracting Leveling Jacks	238
Lights	194
Interior Halogen	194
Map Lights	194
Limited Warranty Transfer Application ..	15
LP-Gas Consumption	175
LP-Gas Detector	168
Testing.....	169
Alarm	170
Maintenance.....	170
LP-Gas Distribution Lines	175
LP-Gas Emergency Procedures Checklist	170
LP-Gas Fundamentals	172
LP-Gas Hose Inspection	174
LP-Gas Regulator	173
LP-Gas Safety Tips	176
LP-Gas Systems	168
LP-Gas Tank	171
Measurement.....	171
Tank Capacity	171
Tank Filling.....	171
Tank Operation.....	172
Accessory Hookup	172

Lubrication Charts	260
Cummins ISM	260
Cummins ISX (OPT)	262
Detroit Diesel Series 60 (OPT)	264
Lubrication Maintenance	258

M,N,O

Master Off Switch	180
Microwave/Convection Oven	99
Setting the Clock	100
Care & Cleaning	100
Mold & Mildew	83

P,Q

Pest Control	84
Plumbing Manifold	152
Power Sunvisor	133
Power Super Slide (OPT)	136
Pressure Accumulator Tank	153
Privacy Drape- Electric (OPT)	133

R

Rear View System.....	26
Refrigerator	92
Operation Specifics	92
Control Panel	93
Icemaker.....	94
Refrigerator Alarm	95
Cooling Unit Fans	95
Doors.....	95
Storage Procedures.....	95
Interior Light.....	95
Service.....	96
Air in LP-Gas Supply Lines.....	96
Refrigerator - Residential (OPT).....	96
Reporting Safety Defects	4

S

Safe (OPT)	53
Safety Terms	4
Satellite.....	146
Stationary System	146
In-Motion System (OPT)	148
Satellite Radio (OPT).....	138
Seat Controls	134
Swivel Seats	134
Security System (OPT)	52
Basic Operations	52
System Override.....	53
Service Center	164
Set-Up Procedures.....	29
Shock Absorber	232

Shore Power Hook-up.....	180
Power Cord Reel	182
120 Volt AC & Amp Display	182
Shower.....	78
Slide-out Operation.....	125
Extending & Retracting Slide Rooms..	126
Manual Override (HWH).....	127
Manual Override-Lippert.....	127
Bedroom Slide-Out	128
Smoke Detector	53
Operation.....	54
Testing.....	54
Maintenance.....	54
Troubleshooting	54
Sofa Bed Conversion.....	134
Solar Panel (OPT)	193
Charge Controller.....	193
Solar Panel Care	193
Specifications Charts	266
Tank Capacities	266
Engine Specifications.....	266
Chassis Fluid Capacities	267
Generator Specifications	267
Belts & Filters	267
Stainless Steel Surfaces.....	81
Starting Procedure.....	242
Normal Starting.....	242
Cold Weather.....	242
Steering Column & Smart Wheel.....	200
Smart Wheel Operation.....	200
Wiper Function	201
Tilt & Telescope.....	202
Steering Gear.....	228

Storage	86
Short Term.....	86
Long Term.....	87
Winter Storage Checklist	89
Removal from Storage	89
Super Slide (OPT)	136
Survey	13
System Control Center	213

T

Tag Axle	231
Oil Change Intervals	231
Tires	36
Importance of Air Pressure	37
Tire Pressure Inflation Guideline	37
Tire Chart - Goodyear	38
Inspecting & Pressure	39
Air Pressure Checklist.....	39
Supporting When Leveling	40
Tire Vibration	40
Tire Rotation	41
Tread	41
Storage of Tires - Long Term	41
Toilet	160
Cleaning & Maintenance	161
Drain Traps & Auto Vents.....	161
Cold Weather Conditions	161
Cold Weather Storage	161
Towing Procedures	35
Disabling Parking Brake	36
Transfer Switch	183
Transmission	248
Check Trans Indicator	249
Periodic Inspections	250

Transmission Fluid & Filters	250
Trip Preparation	23
TV & Entertainment Components	142
Television (Front) Lockout Feature	142
Connections - Cable TV, Computer & Phone	143
Television Inputs	143
Television - Ceiling Mounted (OPT) ...	143
Antenna Boost.....	143
TV Antenna	143
Television/Entertainment System - Front	144
Television-Bedroom.....	145

U

Universal Remote	145
-------------------------------	------------

V

Vendor List	7
Vorad Safety System (OPT)	50
Side Sensors Display.....	51
VORAD Driver Display	51
SmartCruise® - Operation	51
Special Situations.....	52

W,X,Y,Z

Wall Coverings	78
Wall Thermostat	103
Warranty - Monaco: 2006 Executive	i
Warranty - 2006 Roadmaster	iii
Warranty Information File	4
Washer (OPT)	113
Test Cycle.....	113
Operating Instructions.....	114
Cleaning the Washer	115
Winterizing the Washer	115
Washer-Dryer (OPT)	111
Test Procedure.....	111
Washer/Dryer Maintenance.....	112
Winterizing the Washer/Dryer	113
Washer-Dryer Prepared	110
Waste Water Systems	158
Proper Waste Disposal	158
What Not to Put in Waste Holding Tanks.....	158
What to Put in Holding Tanks.....	159
Waste Pump.....	159
Water- Potable	151
Hose Reel	151
City Hook-Up.....	151
Fresh Tank Fill	151
Gravity Fill.....	152
Water Bay	165
Water Dispenser - Hot (OPT)	98
Water Filters	154
Galley Water Filter & Sanitizer (OPT)	154
Maintenance.....	155
Water Pump	152
Water Pump Troubleshooting.....	153
Water System Diagram	166

Water Systems	156
Troubleshooting	156
Disinfecting Fresh Water	156
Water Systems - Introduction	150
Water Tanks.....	150
Measurements & Calibration	150
Weighing the Motorhome.....	42
Weight Terms	42
Weight Label.....	45
Six-Point Weighing Example	46
Cargo Carrying Capacity Flowchart	48
Weighing Procedure Worksheet	49
Weight Record Sheet.....	50
Wheel Mounting.....	41
Windows.....	81
Condensation.....	81
Window Treatments.....	82
Mini-Blinds	82
Day/Night Shades	82
Winterization.....	162
Using Air Pressure	162
Using Nontoxic Antifreeze	162
De-Winterization.....	163
Wood Care	79