

WARRANTY - LIMITED: KNIGHT 2005 .....1  
WARRANTY - LIMITED: 2005 ROADMASTER CHASSIS ...5  
WARRANTY INFORMATION FILE .....10

## WARRANTY - LIMITED: KNIGHT 2005

### MONACO MOTORHOME LIMITED WARRANTY

#### What the Period of Coverage is:

If you use your Monaco® motorhome only for recreational travel and family camping purposes, the Limited Warranty provided by Monaco ("Warrantor") covers your new motorhome when sold by an authorized dealer, for twelve (12) months from the original retail purchase date or the first 24,000 miles of use, whichever occurs first. However, the Limited Warranty provided by Warrantor covers the steel or aluminum frame structure of the sidewalls (excluding slide outs), roof, and rear and front walls for sixty (60) months from the original retail purchase date or the first 50,000 miles of use, whichever occurs first.

If you use your motorhome for any rental, commercial or business purposes whatsoever, the Limited Warranty provided by Warrantor covers your new motorhome when sold by an authorized dealer for ninety (90) days from the original retail purchase date or the first 24,000 miles of use, whichever occurs first. In addition, the Limited Warranty provided by Warrantor covers the steel or aluminum frame structure of the sidewalls (excluding slide outs), roof, and rear and front walls for twelve (12) months from the original retail purchase date or the first 24,000 miles of use, whichever occurs first. A conclusive presumption that your motorhome has been used for commercial and/or business purposes arises if you have filed a federal or state tax form claiming any business tax benefit related to your ownership of the motorhome.

The above Limited Warranty coverage applies to all owners, including subsequent owners, of the motorhome. However, a subsequent owner must submit a warranty transfer form by filing the form through an authorized Monaco dealer. A subsequent owner's warranty coverage period is the remaining balance of the warranty coverage period the prior owner was entitled to under this Limited Warranty. Warranty transfer forms can be obtained by contacting the Customer Relations Department. There is no charge for the transfer.

## ***Limitations of Implied Warranties***

**ANY IMPLIED WARRANTIES ARISING BY WAY OF STATE LAW, INCLUDING ANY IMPLIED WARRANTY OF MERCHANTABILITY AND ANY IMPLIED WARRANTY OF FITNESS FOR A PARTICULAR PURPOSE, ARE LIMITED IN DURATION TO THE TERM OF THIS LIMITED WARRANTY AND ARE LIMITED IN SCOPE OF COVERAGE TO THOSE PORTIONS OF THE MOTORHOME COVERED BY THIS LIMITED WARRANTY.**

Warrantor disclaims all implied and express warranties, including the implied warranty of merchantability and the implied warranty of fitness for a particular purpose, on components and appliances excluded from coverage as set forth below. There is no warranty of any nature made by Warrantor beyond that contained in this Limited Warranty. No person has authority to enlarge, amend or modify this Limited Warranty. The dealer is not the Warrantor's agent but is an independent entity. Warrantor is not responsible for any undertaking, representation or warranty made by any dealer or other person beyond those expressly set forth in this Limited Warranty. Some states do not allow limitations on how long an implied warranty lasts, so the above limitation may not apply to you.

---

## ***What the Warranty Covers***

Warrantor's Limited Warranty covers defects in the manufacture of your motorhome and defects in materials used to manufacture your motorhome. Also see the section "What the Warranty Does Not Cover" set out below.

---

## ***What We Will Do to Correct Problems***

Warrantor will repair and/or replace, at its option, any covered defect if: (1) you notify Warrantor or one of its authorized servicing dealers of the defect within the warranty coverage period and within five (5) days of discovering the defect; and (2) you deliver your Motorhome to Warrantor or Warrantor's authorized servicing dealer at your cost and expense. It is reasonable to expect some service items to occur during the warranty period. The performance of warranty repairs shall not extend the original warranty coverage period. Further, any performance of repairs after the warranty coverage period has expired or any performance of repairs to component parts and appliances excluded from coverage shall be considered "good will" repairs, which shall not alter the express terms of this limited warranty.

Warrantor may use new and/or remanufactured parts and/or components of substantially equal quality to complete any repair.

Defects and/or damage to interior and exterior surfaces, trim, upholstery and other appearance items may occur at the factory during manufacture, during delivery of the motorhome to the selling dealer or on the selling dealer's lot. Normally, any such defect or damage is detected and corrected at the factory or by the selling dealer during the inspection process performed by the Warrantor and the selling dealer. If, however, you discover any such defect or damage when you take delivery of the motorhome, you must notify your dealer or Warrantor within five days of the date of purchase to have repairs performed to the defect at no cost to you as provided by this Limited Warranty.

If either three or more unsuccessful repair attempts have been made to correct any covered defect that you believe substantially impairs the value, use or safety of your motorhome or repairs to any covered defect(s), which you believe substantially impairs the value, use or safety of your motorhome, have taken 30 or more days to complete, you must, to the extent permitted by law, notify Warrantor directly in writing of the failure to successfully repair the defect(s) so that Warrantor can become directly involved in exercising a final repair attempt for the purpose of performing a successful repair to the identified defect(s).

---

### ***How to Get Service***

The Warranty Registration form must be returned to Warrantor promptly upon purchase to assure proper part replacement and repair of your motorhome. Failure to return the warranty registration form will not affect your rights under the Limited Warranty so long as you can furnish proof of purchase. For warranty service simply contact one of Warrantor's authorized service centers for an appointment, then deliver your motorhome (at your expense) to the service center. If you need assistance in locating an authorized warranty service facility, contact:

**Warranty Department  
1-877-466-6226  
91320 Coburg Industrial Way  
Coburg, Oregon 97408.**

In the event the motorhome is inoperative due to malfunction of a warranted part, Warrantor will pay the cost of having the motorhome towed to the nearest authorized repair facility provided you notify Warrantor prior to incurring the towing charges to receive directions to the nearest repair facility.

Because Warrantor does not control the scheduling of service work by its authorized servicing dealers, you may encounter some delay in scheduling and/or in the completion of the repairs.

## ***What the Warranty Does Not Cover***

This Limited Warranty does not cover: any motorhome sold or registered outside of the United States or Canada; items which are added or changed after the motorhome leaves Warrantor's possession; items that are working as designed but which you are unhappy with because of the design; normal wear and usage, such as fading or discoloration of fabrics, or the effects of condensation inside the motorhome; defacing, scratching, dents and chips on any surface or fabric of the motorhome, not caused by Warrantor; routine maintenance, including by way of example wheel alignments; the automotive chassis and power train, including, by way of example the engine, drivetrain, steering and handling, braking, wheel balance, muffler, tires, tubes, batteries and gauges; appliances and components covered by their own manufacturer's warranty including, by way of example the microwave, refrigerator, ice maker, stove, oven, generator, roof air conditioners, hydraulic jacks, VCR, television(s), water heater, furnace, stereo, radio, compact disc player, washer, dryer, inverter and cellular phone; or flaking, peeling and chips or other defects or damage in or to the exterior or finish caused by rocks or other road hazards, the environment including airborne pollutants, salt, tree sap and hail.

---

## ***Events Discharging Warrantor from Obligation Under Warranty***

Misuse or neglect, accidents, unauthorized alteration, failure to provide reasonable and necessary maintenance (See Owner's Manual), damage caused by off road use, collision, fire, theft, vandalism, explosions, overloading in excess of rated capacities, and odometer tampering shall discharge Warrantor from any express or implied warranty obligation to repair any resulting defect.

---

## ***Disclaimer of Consequential & Incidental Damages***

**THE ORIGINAL PURCHASER OF THE MOTORHOME AND ANY PERSON TO WHOM THE MOTORHOME IS TRANSFERRED, AND ANY PERSON WHO IS AN INTENDED OR UNINTENDED USER OR BENEFICIARY OF THE MOTORHOME , SHALL NOT BE ENTITLED TO RECOVER FROM WARRANTOR ANY CONSEQUENTIAL OR INCIDENTAL DAMAGES RESULTING FROM ANY DEFECT IN THE MOTORHOME. THE EXCLUSION OF CONSEQUENTIAL AND INCIDENTAL DAMAGES SHALL BE DEEMED INDEPENDENT OF, AND SHALL SURVIVE, ANY FAILURE OF THE ESSENTIAL PURPOSE OF ANY LIMITED REMEDY.** Some states do not allow the exclusion or limitation of consequential or incidental damages, so the above exclusions may not apply to you.



**THESE WARRANTIES ARE NOT INTENDED TO "EXTEND TO FUTURE PERFORMANCE." ANY ACTION TO ENFORCE THESE EXPRESS OR ANY IMPLIED WARRANTIES SHALL NOT BE COMMENCED MORE THAN NINETY (90) DAYS AFTER THE EXPIRATION OF THE ONE YEAR WARRANTY COVERAGE PERIOD DESIGNATED ABOVE. IF YOU USE YOUR MOTORHOME FOR COMMERCIAL OR BUSINESS PURPOSES, ANY ACTION TO ENFORCE THESE EXPRESS OR ANY IMPLIED WARRANTIES SHALL NOT BE COMMENCED MORE THAN ONE YEAR AFTER THE EXPIRATION OF THE NINETY (90) DAY WARRANTY COVERAGE PERIOD DESIGNATED ABOVE. THE PERFORMANCE OF REPAIRS SHALL NOT SUSPEND THIS LIMITATIONS PERIOD FROM EXPIRING. THESE TERMS AND ALL EXPRESS AND IMPLIED WARRANTY DISPUTES BETWEEN WARRANTOR AND PURCHASER SHALL BE GOVERNED BY THE SUBSTANTIVE LAWS OF THE STATE OF INDIANA, WITHOUT REGARD TO CONFLICTS OF LAW RULES.** Some states do not allow the reduction in the statute of limitations or a choice of law provision, so the above reduction in the statute of limitations and/or choice of law provision may not apply to you.

**THIS WARRANTY GIVES YOU SPECIFIC LEGAL RIGHTS. YOU MAY ALSO HAVE OTHER RIGHTS, WHICH VARY FROM STATE TO STATE.**

---

## **WARRANTY - LIMITED ROADMASTER CHASSIS**

### **What the Period of Coverage Is:**

If you use the Roadmaster Chassis that your motorhome is mounted upon for only recreational travel and family camping purposes, the Limited Warranty provided by Roadmaster ("Warrantor") covers your Roadmaster Chassis for thirty-six (36) months from the original retail purchase date or the first 36,000 miles of use, whichever occurs first.

If you use the Roadmaster Chassis that your motorhome is mounted upon for any rental, commercial or business purposes whatsoever, the Limited Warranty provided by Warrantor covers your new Roadmaster Chassis for Ninety (90) days from the original retail purchase date of the motorhome or the first 24,000 miles of use, whichever occurs first. A conclusive presumption that the Roadmaster Chassis has been used for commercial and/or business purposes arises if you have filed a federal or state tax form claiming any business tax benefit related to your ownership of the motorhome.

## ***Limitations of Implied Warranties***

**ANY IMPLIED WARRANTIES ARISING BY WAY OF STATE LAW, INCLUDING ANY IMPLIED WARRANTY OF MERCHANTABILITY AND ANY IMPLIED WARRANTY OF FITNESS FOR A PARTICULAR PURPOSE, ARE LIMITED IN DURATION TO THE TERM OF THIS LIMITED WARRANTY AND ARE LIMITED IN SCOPE OF COVERAGE TO THOSE PORTIONS OF THE ROADMASTER CHASSIS COVERED BY THIS LIMITED WARRANTY.** Warrantor disclaims all implied and express warranties, including the implied warranty of merchantability and the implied warranty of fitness for a particular purpose, on components and appliances excluded from coverage as set forth below. There is no warranty of any nature made by Warrantor beyond that contained in this Limited Warranty. No person has authority to enlarge, amend or modify this Limited Warranty. Any dealer selling a motorhome assembled upon a Roadmaster Chassis is not the Warrantor's agent but is an independent entity. Warrantor is not responsible for any undertaking, representation or warranty made by any dealer or other person beyond those expressly set forth in this Limited Warranty. Some states do not allow limitations on how long an implied warranty lasts, so the above limitation may not apply to you.

---

## ***What the Warranty Covers***

Warrantor's Limited Warranty covers defects in the manufacture of the Roadmaster Chassis and defects in materials used to manufacture the Roadmaster Chassis.

---

## ***What We Will Do to Correct Problems***

Warrantor will repair and/or replace, at its option, any covered defect if: (1) you notify Warrantor or one of its authorized servicing dealers of the defect within the warranty coverage period and within five (5) days of discovering any such defect; and (2) you deliver the Roadmaster Chassis to Warrantor or Warrantor's authorized servicing dealer at your cost and expense. It is reasonable to expect some service items to occur during the warranty period. The performance of warranty repairs shall not extend the original warranty coverage period. Further, any performance of repairs after the warranty coverage period has expired or any performance of repairs to component parts and appliances excluded from coverage shall be considered "good will" repairs, which shall not alter the express terms of this limited warranty.

Warrantor may use new and/or remanufactured parts and/or components of substantially equal quality to complete any repairs.

Defect and/or damage to the Roadmaster Chassis may occur during manufacture at the factory, during delivery of the motorhome to the selling dealer or on the selling dealer's lot. Normally, any factory defect or damage is detected and corrected at the factory or by the selling dealer during the inspection process performed by the Warrantor and the selling dealer. If, however, you discover any such defect or damage when you take delivery of the Roadmaster Chassis, you must notify your dealer or Warrantor within five days of the date of purchase to have repairs performed to any such defect at no cost to you as provided by this Limited Warranty.

If either three or more unsuccessful repair attempts have been made to correct any covered defect that you believe substantially impairs the value, use or safety of your motorhome or repairs to any covered defect(s), which you believe substantially impairs the value, use or safety of your motorhome, have taken 30 or more days to complete, you must, to the extent permitted by law, notify Warrantor directly in writing of the failure to successfully repair the defect(s) so that Warrantor can become directly involved in exercising a final repair attempt for the purpose of performing a successful repair to the identified defect(s).

---

### ***How to Get Service***

For warranty service simply contact one of Warrantor's authorized service centers for an appointment, then deliver your Roadmaster Chassis (at your expense) to the service center. If you need assistance in locating an authorized warranty service facility, contact

**Warranty Department  
1-877-466-6226  
91320 Coburg Industrial Way  
Coburg, Oregon 97408**

In the event the Roadmaster Chassis is inoperative due to malfunction of a warranted part, Warrantor shall pay the cost of having the Roadmaster Chassis that the motorhome is mounted upon towed to the nearest authorized repair facility provided you notify Warrantor prior to incurring the towing charges to receive directions to the nearest repair facility.

Because Warrantor does not control the scheduling of service work by its authorized servicing dealers, you may encounter some delay in scheduling and/or in the completion of the repairs.

## ***What the Warranty Does Not Cover***

This Limited Warranty does not cover: modifications and alterations to the Roadmaster Chassis by others; the motorhome that is mounted upon the Roadmaster Chassis, including by way of example the motorhome manufacturer's design, manufacture, assembly and/or installation of the side walls, roof, windows, flooring, electrical system, plumbing system, LP gas system, appliances and slide outs; items that are working as designed but which you are unhappy with because of the design; normal wear and usage; routine maintenance including by way of example wheel alignments; component parts covered by their own manufacturer's warranty, including by way of example the engine, transmission, tires, tubes, batteries, exhaust system and the emission control systems; and, flaking, peeling, rusting and chips or other defects or damage in or to the frame and frame cross members caused by rocks or other road hazards and the environment including airborne pollutants and salt.

---

## ***Events Discharging Warrantor from Obligation Under Warranty***

Misuse or neglect, accidents, unauthorized alteration, failure to provide reasonable and necessary maintenance (See Owner's Manual), damage caused by off road use, collision, fire, theft, vandalism, explosions, overloading in excess of rated capacities, and odometer tampering shall discharge Warrantor from any express or implied warranty obligation to repair any resulting defect.

---

## ***Disclaimer of Consequential & Incidental Damages***

**THE ORIGINAL RETAIL PURCHASER OF THE ROADMASTER CHASSIS AND ANY PERSON TO WHOM THE ROADMASTER CHASSIS IS TRANSFERRED, AND ANY PERSON WHO IS AN INTENDED OR UNINTENDED USER OR BENEFICIARY OF THE ROADMASTER CHASSIS, SHALL NOT BE ENTITLED TO RECOVER FROM WARRANTOR ANY CONSEQUENTIAL OR INCIDENTAL DAMAGES RESULTING FROM ANY DEFECT IN THE MOTORHOME. THE EXCLUSION OF CONSEQUENTIAL AND INCIDENTAL DAMAGES SHALL BE DEEMED INDEPENDENT OF, AND SHALL SURVIVE, ANY FAILURE OF THE ESSENTIAL PURPOSE OF ANY LIMITED REMEDY.** Some states do not allow the exclusion or limitation of consequential or incidental damages, so the above exclusions may not apply to you.

**THESE WARRANTIES ARE NOT INTENDED TO "EXTEND TO FUTURE PERFORMANCE." ANY ACTION TO ENFORCE THESE EXPRESS OR ANY IMPLIED WARRANTIES SHALL NOT BE COMMENCED MORE THAN NINETY (90) DAYS AFTER THE EXPIRATION OF THE ONE YEAR WARRANTY COVERAGE PERIOD DESIGNATED ABOVE. IF YOU USE YOUR ROADMASTER CHASSIS FOR COMMERCIAL OR BUSINESS PURPOSES, ANY ACTION TO ENFORCE THESE EXPRESS OR ANY IMPLIED WARRANTIES SHALL NOT BE COMMENCED MORE THAN ONE YEAR AFTER THE EXPIRATION OF THE NINETY (90) DAY WARRANTY COVERAGE PERIOD DESIGNATED ABOVE. THE PERFORMANCE OF REPAIRS SHALL NOT SUSPEND THIS LIMITATIONS PERIOD FROM EXPIRING. THESE TERMS AND ALL EXPRESS AND IMPLIED WARRANTY DISPUTES BETWEEN WARRANTOR AND PURCHASER SHALL BE GOVERNED BY THE SUBSTANTIVE LAWS OF THE STATE OF INDIANA, WITHOUT REGARD TO CONFLICTS OF LAW RULES.** Some states do not allow the reduction in the statute of limitations or a choice of law provision, so the above reduction in the statute of limitations and/or choice of law provision may not apply to you.

**THIS WARRANTY GIVES YOU SPECIFIC LEGAL RIGHTS. YOU MAY ALSO HAVE OTHER RIGHTS, WHICH VARY FROM STATE TO STATE.**

**Roadmaster Chassis Division  
Monoaco Coach Corporation  
91320 Coburg Industrial Way  
Coburg, Oregon  
97408**

## WARRANTY INFORMATION FILE

In addition to this Owner's Manual you will find a Warranty Information File in your unit. This file contains valuable documents about your motorhome systems and equipment. Many of the component manufacturer warranty registration cards can be found in the box. They will need to be filled out and mailed. Be sure you read and understand all the information in this file to help you safely operate, maintain and troubleshoot those items.

### WOOD FINISH

Because no two trees look alike, authentic woods vary in color and character markings such as streaks, knots and grain patterns.

Since the stains may attach differently to these grain patterns, some natural light and dark areas may result. The beauty lies in these natural variations of color and grain that give each cabinet its own individual charm.

The beauty of these products is protected with a furniture-quality exterior finish. After a period of time, there may be minimal changes in the finish color as it ages in its surrounding conditions.

This is an inherent characteristic of this particular finish, and the natural aging process adds to the unique appearance of the cabinetry.

Due to the minor differences in tone, it may not be possible to match the finish color of existing cabinets exactly when replacing doors or adding additional cabinets at a later date.

The foregoing is not a warning. See the Limited Warranty or call (877) 466-6226 for warranty information and limitations.

# *Knight*

Monaco

## *Sections*

---

General Information ~ 1

---

Driving & Safety ~ 2

---

Exterior & Interior Care ~ 3

---

Appliances ~ 4

---

Equipment ~ 5

---

Water Systems ~ 6

---

LP-Gas Systems ~ 7

---

Electrical Systems - House ~ 8

---

Electrical Systems - Chassis ~ 9

---

Chassis Information ~ 10

---

Index ~ pp 385



The information contained in this document is intended to reflect standard and optional equipment included in a typically equipped model at the time of delivery to the initial retail owner. Your actual unit may vary from this document as a result of optional equipment that is not generally offered on this model. In the case that you are not the initial retail owner of this unit, this document will not reflect modifications that may have been performed by previous owners.

Product information and specifications are shown herein as of the time of printing. The motorhome manufacturer reserves the right to change product specifications, designs and standard equipment without notice and without incurring obligation.

©Copyright Monaco Corporation. All rights reserved. The Knight is a trademark of Monaco Corporation. All other trademarks or registered trademarks are property of their respective holders. Brand name products of other companies mentioned in this manual are not endorsed by the manufacturer of the motorhome.

# *General Information*

## *Section 1*

<b>SAFETY LEGEND</b> .....	<b>15</b>
<b>INTRODUCTION</b> .....	<b>16</b>
<b>CUSTOMER RELATIONS</b> .....	<b>17</b>
<b>REPORTING SAFETY DEFECTS</b> .....	<b>17</b>
<b>TAKING DELIVERY</b> .....	<b>17</b>
Monaco Responsibilities .....	17
Dealer Responsibilities.....	18
Customer Responsibilities .....	18
<b>SERVICE SUGGESTIONS</b> .....	<b>18</b>
Prepare for the Appointment .....	19
Prepare a List.....	19
Be Reasonable With Your Requests .....	19
No Looking Over the Technician's Shoulder .....	19
Inspect the Work Properly.....	19
<b>GLOSSARY OF TERMS</b> .....	<b>20</b>
<b>VENDOR LIST</b> .....	<b>24</b>
<b>LIMITED WARRANTY TRANSFER APPLICATION</b> .....	<b>27</b>



---

## SAFETY LEGEND

**WARNING** - Information pertaining to personal safety and/or potential extensive damage to the motorhome.

**CAUTION** - Information pertaining to potential damage to the motorhome and/or its components.

**DANGER** - Information pertaining to danger or caution of potential electrical shock to person(s) or component(s), and/or risk of electrical fire to motorhome.

**FLAMMABLE** or **EXPLOSIVE** - Information concerning fire or explosive material pertaining to personal safety and/or protection of the motorhome and its components.

**POISON** - Information pertaining to safety and/or use of a poisonous substance or harmful chemical.

**NOTE** - Information and reminders concerning operation of motorhome and/or components.

**INSPECT** - Inspection of the motorhome and/or its components is required. Additional instruction may follow.

**LUBE** - Lubrication, or addition of lubricant product, to the motorhome and/or a specified component or part is required. Additional instruction may follow.

**ASSEMBLE/REPAIR** - Assembly, disassembly or installation of a component or part, and/or repair to the motorhome may be required. Assistance of Technical Support or Technician may be necessary.

**INFORMATION** - References to additional information regarding operation of the motorhome and/or its components found in additional sources other than the Owner's Manual. Also refers to the WARRANTY INFORMATION FILE, found within the Warranty Information Box inside the motorhome.

**TIP** - Information regarding helpful hints and/or suggestion for ease of operation of the motorhome and/or its components.

## INTRODUCTION

This section contains warranty information and knowledge for the operation and care of the motorhome. Not all information may be applicable to your model of motorhome. More detailed information with CAUTION or WARNING instructions, other than what is found in this chapter, can be found in the manufacturer's owner manuals located in the owner information box.

Changes, additions and supplemental information in the form of Manual Addendums can be obtained by visiting our Website at [www.holidayrambler.com](http://www.holidayrambler.com). Select one of the products from the product lineup. Go to the Service menu. A submenu will appear. Browse our other product lines Technical Tips. These Tips may not completely apply to your particular model but information contained therein can be useful.

In time you will develop a knack for spotting wonderful little roadside locations by turning off the main highway and exploring. There are many modern recreational vehicle parks (including state, county and federal parks) with good facilities where you can obtain hook-ups for electrical, water and sewage connections. Directories are published which describe these parks and the availability of services and hook-ups. On overnight or weekend trips, chances are you will probably not fill up the sewage holding tanks, deplete the water or LP-Gas supply, or run down the batteries which supply the living area with 12 Volt DC current. On longer trips, when you have stayed where sewer connections and utility hook-ups were not available, it will be necessary to occasionally empty the holding tanks and replenish the water and LP-Gas supply.

Many gas stations have installed sanitary dumping stations. Publications are available which list these dumping stations. When stopped for the night, the motorhome is built to be safely parked in any spot that is relatively level and where the ground is firm. Try to pick as level a parking spot as possible. Your facilities are with you and the motorhome is fully self-contained.

Many of the safety alert symbols are "Personal Safety Instructions." Definitions for the symbols are located on a previous page under "Safety Symbol Legend." It is important to thoroughly read and understand these safety instructions where the symbols are displayed throughout the manual. Failure to comply with specific instructions may result in personal injury or death. Many instructions are required by National Safety Associations.

---

## **CUSTOMER RELATIONS**

Only by ensuring your confidence and satisfaction with our products and services can we have continued success as a manufacturer of motorhomes. We believe a good relationship with our customers is just as important as improving the technical excellence of our products. Your authorized dealer is pleased to help you with instructions about your motorhome and to offer service when you need it. If problems remain after you have consulted your dealer you are invited to contact our Customer Service Department. Please have all pertinent information (serial numbers, model number, etc.) when calling. We will work with the dealer and see that every attempt to resolve the matter is made.

**Customer Service Department  
91320 Coburg Industrial Way  
Coburg, Oregon 97408  
877-466-6226**

---

## **REPORTING SAFETY DEFECTS**

If you believe that your motorhome has a defect which could cause a crash or could cause injury or death, you should immediately inform the National Highway Traffic Safety Administration (NHTSA) in addition to notifying Monaco. If NHTSA receives similar complaints, it may open an investigation, and if it finds that a safety defect exists in a group of motorhomes, it may order a recall or remedy campaign. However, NHTSA cannot become involved in individual problems between you, your dealer or Monaco. To contact NHTSA you may either call the Auto Safety Hot line toll-free at 1-800-424-9393 (or 1-202-366-0123 in the Washington D.C. area) or write to:

**NHTSA  
U.S. Department of Transportation  
400 Seventh Street, S.W.  
Washington, DC 20590**

---

## **TAKING DELIVERY - *Monaco Responsibilities***

Your motorhome has been manufactured to the highest quality and standards by factory trained personnel. Quality inspections are performed throughout the manufacturing process of your motorhome. The motorhome has been carefully and almost completely hand assembled in our factory. Prior to the motorhome arriving at the dealership, all systems have been carefully tested and inspected to ensure optimum performance. The necessary forms and required manuals have been placed in the motorhome at the time of shipment to the dealership.

## **Dealer Responsibilities**

The dealer must perform additional pre-delivery inspections and system checks, assist in the customer's understanding of the Limited Warranty and assist in completing any necessary forms. They must do a customer orientation to the motorhome, its systems, components and their operation.

The dealer should also ensure the customer receives a complete Owner's Packet with warranty cards and registrations for the motorhome and for separately warranted products, including detailed operating and maintenance instructions. The dealer is responsible for performing a review of the Limited Warranty provisions with the customer, while stressing the importance of mailing warranty cards and registrations to the manufacturers within the prescribed time limit to avoid loss of warranty coverage. They must assist the customer in completing these forms and locating serial numbers. They should request that the customer reads all warranty information when possible and explain any provision not clearly understood.

The dealer should instruct the customer on how to obtain local and out-of-town service on the motorhome and its various individual warranted components, whether the service is warrantable or out of warranty.

---

## **Customer Responsibilities**

As a new motorhome owner you are responsible for regular and proper maintenance. This will help you prevent conditions arising from neglect that are not covered by your Limited Warranty. Maintenance services should be performed in accordance with this Owner's Manual, and any other applicable manuals. As the owner, it is your responsibility and obligation to return the motorhome to an authorized dealer for repairs and service (See the Limited Warranty). Since the authorized dealer where you purchased your new motorhome is responsible for its proper servicing before delivery, and has an interest in your continued satisfaction, we recommend that Inspection, Warranty and Maintenance Services be performed by the dealership. We suggest that you take your new motorhome on a weekend shakedown before leaving on an extended trip.

---

## **SERVICE SUGGESTIONS**

Know when to take your motorhome in for service. Give some thought to the appointment time. There are several things to consider when selecting a time for service. Location of the service center and the time of year can be a major issue. Monday and Friday are busy days for most dealers. Therefore, it makes sense to make a mid-week appointment whenever possible. Ask your dealer if additional time is needed for check in and completion of paperwork.



---

## ***Prepare for the Appointment***

If you're having warranty work done, be sure to have your warranty registration papers with you. All work to be performed may not be covered by the warranty; be sure to discuss additional charges with the service manager. Keep a maintenance log of your motorhome service history. This can often provide a clue to the current problem.

---

## ***Prepare a List***

Make a written list of specific repairs needed. It is important the service manager be aware of all previous work which has been done on your motorhome. For example: if the motorhome has been repaired due to an accident. While this may not seem important, it could have a significant effect on the dealer's diagnosis of a problem.

---

## ***Be Reasonable With Your Requests***

Do not leave a list of 20 items to be serviced and expect to have the motorhome back by 5:00 p.m. If you list a number of items, and must have your motorhome back by the end of the day, discuss the situation with the service manager and list items in order of priority. Some items may not be able to be repaired due to work loads or parts availability. Expect to make a second appointment for work not completed or for the long, drawn-out repair item.

---

## ***No Looking Over the Technician's Shoulder***

Please do not be offended when you are told you cannot watch the work being done. Many service area insurance requirements forbid the admission of customers into the service work area.

---

## ***Inspect the Work Properly***

Check out the service or repair job when you pick up your motorhome and notify the service manager of any dissatisfaction. If circumstances prevent returning for immediate corrective work, make an appointment as soon as possible.

## GLOSSARY OF TERMS

**AC Electricity** - Alternating current also known as household power.

**Air Compressor** - Pumps air to and builds air pressure in an air system.

**Air Dryer** - Cools, filters and dries the air delivered by an air compressor.

**Air Governor** - Controls the operation of the air compressor by constantly monitoring air pressure in the supply tank of the air system. The air governor initiates the unload cycle when the cut-out pressure is reached. The air governor also controls the air dryer by sending an air signal (at the beginning of the compressor unload cycle) to the control port of the air dryer, initiating the purge cycle. When this air signal is removed by the governor (at the beginning of the compressor load cycle) the purge valve closes and the drying cycle begins.

**Ampere (Amp)** - The unit of measure of electron flow rate of current through a circuit.

**Ampere-hour (Amp-hr. AH)** - A unit of measure for a battery electrical storage capacity, obtained by multiplying the current in amperes by the time in hours of discharge. (Example: A battery which delivers 5 amperes for 20 hours, delivers 5 amperes times 20 hours, or 100 Amp-Hr. of capacity.)

**Black Water** - Term associated with the sewage holding tank. The toilet drains directly into this tank.

**CCA** - Cold Cranking Amperage is the amount of current a battery can deliver for 30 seconds at zero degrees F without dropping below a specified voltage, usually 10.5 Volts DC.S

**Chassis Battery** - Powers chassis 12 Volt accessories and starts engine.

**Circuit** - An electric circuit is the path of an electric current. A closed circuit has a complete path. An open circuit has a broken or disconnected path.

**City Water** - A term associated with the water supply that you hook-up to at campgrounds. It is called city water because water is pulled from a central source (like in a city) and not the fresh water tank.

**Compressor Load Cycle** - The time during which the air compressor is building air pressure in an air system.

**Compressor Unload Cycle** - The time during which the air compressor is idling and is not building air pressure in an air system.

**Curbside** - This refers to the side of the motorhome which faces the curb when it is parked. Often called the door side or the passenger's side.

**Current - Alternating (AC)** - A current that varies periodically in magnitude and direction. A battery does not deliver alternating current. Also referred to as shore power, utility power, inverter power, generator power, etc.

**Current** - The rate of flow of electricity or the movement rate of electrons along a conductor. It is comparable to the flow of a stream of water. The unit of measure for current is the ampere.

**Cut-In Pressure** - The pressure level in the air system supply tank which triggers the compressor load cycle.

**Cut-Out Pressure** - The pressure level in the air system supply tank which triggers the compressor unload cycle.

**Cycle** - In a battery, one discharge plus one recharge equals one cycle.

**DC Electricity** - Direct current also known as battery power.

**Desiccant** - A granular substance that has a high affinity for water and is used to retain moisture from the air stream flowing through the air dryer cartridge.

**Direct Current (DC)** - Power that is stored in a battery bank or supplied by photovoltaics, alternator, chargers and DC generators.

**Drain Trap** - This is a curve that is in all drains. Water is trapped in the curve and this creates a barrier so tank odors cannot escape through the drain.

**Dry Camping** - Camping in the motorhome when there is no city water hook-up or shore power. In other words, using only the water and power that is in the motorhome and not from another source.

**Drying Cycle** - The time during which the air dryer cools, filters and removes moisture from the air delivered by the air compressor. The drying cycle begins and ends the same as the compressor load cycle.

**Dump Station** - A site where the waste (grey) and sewage (black) tanks can be drained. In most states it is illegal to drain waste tanks anywhere other than at a dump station.

**Dump Valve** - Another name for the T-handle valve used to drain the sewage (black) and waste (grey) tanks.

**Egress Window** - The formal name for the emergency window located in the rear of the motorhome. Egress windows can be easily identified by their red handles.

**Full Hook-Up Site** - A campground that has city water, shore power and sewer hook-ups or connections available.

**Grey Water** - Term associated with the waste water holding tank. Water from the sink drains, the shower and the washer/dryer (if equipped) go into this tank.

**House Battery** - Powers 12 Volt lights and accessories inside motorhome.

**LED** - (Light Emitting Diode) Indicator light.

**Low Point Drain** - The lowest point in the plumbing. Drains are placed here so that water will drain out of the lower end of the motorhome. These drains must be closed when you fill the water tank.

**OHM** - A unit for measuring electrical resistances.

**Ohm's Law** - Express the relationship between Volt (E), amperes (I) in an electrical circuit with resistance (R). It can be expressed as follows:  $E = IR$ . If any two of the three values are known, the third value can be calculated by using the above formula.

**Pounds Per Square Inch Gauge (psig)** - Pressure measured with respect to that of the atmosphere. This is a pressure gauge reading in which the gauge is adjusted to read zero at the surrounding atmospheric pressure. It is commonly called gauge pressure.

**Purge** - The initial blast of air (decompression) from the air dryer purge valve at the beginning of the air compressor.

**Purge Cycle** - The time during which the air dryer is undergoing purge and regeneration. This cycle starts at the beginning of the compressor unload cycle and normally ends well before the beginning of the compressor load cycle.

**Regeneration** - The mild backflow of air through the air dryer and out the purge valve that begins immediately after the purge and lasts normally 10 to 15 seconds. This backflow of air, from the air system and through the air dryer, removes moisture from the desiccant cartridge and prepares the air dryer for the next compressor load cycle.

**Roadside** - This refers to the side of the motorhome which faces the road when it is parked. Often called the off-door side or the driver's side.

**Shore Line** - This is the electrical cord which runs from the motorhome to the campground 120 Volt electrical supply.

**Shore Line Plug** - The 120 Volt outlet allows the motorhome to be hooked up to a campground facility.

**Stinger** - An arm attachment on a tow truck that is used to lift motorhome slightly so that it can be towed.

**VIM** - Vehicle Interface Module.

**Volt** - The unit of measure for electric potential.

**Watt** - The unit for measuring electrical power, i.e. the rate of doing work, in moving electrons by or against an electric potential.

**Wet Cell Battery** - A type of battery that uses liquid as an electrolyte. This type of battery requires periodic maintenance such as cleaning the connections and checking the electrolyte level.

## VENDOR LIST

### **Air Bags**

Firestone  
317-818-8600  
www.bridgestone-firestone.com

### **Air Conditioner**

SCS/Frigette  
800-545-6341  
www.scsfrigette.com

### **Air Conditioner - Roof**

Dometic Corp  
574-463-4858  
www.dometic.com

### **Alternator**

Leece-Neville  
800-349-2628  
www.prestolite.com

### **Awnings**

Carefree  
800-338-2378  
www.carefreeofcolorado.com

### **Axles**

Meritor Corporation  
800-535-5560  
www.meritorauto.com

### **Eaton Corporation**

800-328-6687  
www.truck.eaton.com

### **Batteries**

Interstate  
800-272-6548  
www.interstatebatteries.com

### **Brakes (Anti-Lock Brake System)**

Eaton  
800-826-4357  
www.eaton.com

### **Brakes (Exhaust)**

Pac Brake  
800-663-0096  
www.pacbrake.com

### **Carbon Monoxide Detector**

Safe-T-Alert  
800-383-0269  
www.safe-t-alert.com

### **Cooktop**

Atwood Products  
800-873-4328  
www.atwoodmobile.com

### **Dash Radio**

Magnadyne  
800-638-6300

### **DVD Player (Optional)**

RCA  
877-266-2728  
www.rca.com

### **Engine**

Cummins  
800-343-7357  
www.cummins.com

### **Energy Management System (Optional)**

Intellitec  
800-251-2408  
www.intellitecsve.com

### **Entry Step**

Coach Step/Division of SCS/Frigette  
800-275-7524

### **Fan - Bathroom Exhaust**

Fan-Tastic Vent  
800-395-4045  
www.fantasticvent.com

---

**Filters**

Racor Fluid Filters  
800-344-3286  
[www.parker.com/racor/](http://www.parker.com/racor/)

**Fire Extinguisher**

The Fire Extinguisher Co.  
919-563-4911

**Furnace**

Atwood  
800-873-4328  
[www.atwoodmobile.com](http://www.atwoodmobile.com)

**Generator**

Onan  
800-888-6626  
[www.onan.com](http://www.onan.com)

**Holding Tanks/Dumping System**

RV Sani-Con  
800-410-1965  
[www.emptythetanks.com](http://www.emptythetanks.com)

**Inverter**

Magnum Energy Inc.  
425-353-8833  
[www.magnumenergy.com](http://www.magnumenergy.com)

**Leveling Jacks - Hydraulic**

RVA  
760-746-5732

**Liquefied Petroleum Protectors**

MTI Industries, Inc.  
800-383-0269  
[www.mtiindustries.com](http://www.mtiindustries.com)

**LP Tank**

Manchester Tank  
800-877-8265  
[www.mantank.com](http://www.mantank.com)

**Microwave**

Sharp Electronics Corp.  
800-237-4277  
[www.sharp-usa.com](http://www.sharp-usa.com)

**Outside Mirrors**

Ramco Industries, Inc.  
800-321-4819  
[www.ramco-eng.com](http://www.ramco-eng.com)

Velvac Mirror

800-783-8871  
[www.velvac.com](http://www.velvac.com)

**Rear Vision System**

Weldex  
562-404-8736  
[www.weldex.com](http://www.weldex.com)

**Refrigerator**

Norcold  
800-543-1219  
[www.norcold.com](http://www.norcold.com)

**Satellite**

KVH  
401-847-3327  
[www.kvh.com](http://www.kvh.com)

**Shock Absorbers**

Monroe  
800-880-7580  
[www.tenneco-automotive.com](http://www.tenneco-automotive.com)

**Slide-Out Motors**

Power Gear  
800-334-4712  
[www.powergear.com](http://www.powergear.com)

**Steering Gear**

Sheppard  
717-637-3751  
[www.rhsheppard.com](http://www.rhsheppard.com)



**Storage Trays**

Kwikkee  
800-736-9961  
www.kwikkee.com

**Television**

RCA  
877-266-2728  
www.rca.com

**Television Antenna**

Winegard  
319-754-0600  
www.winegard.com

**Tires**

Goodyear Tire & Rubber  
800-399-2772  
www.goodyear.com

**Toilet**

Sealand  
800-321-9886  
www.sealandtechnology.com

**Transfer Switch**

Iota Engineering  
800-866-4682  
www.iotaengineering.com

**Transmission**

Allison Transmission  
800-524-2303  
www.allisontransmission.com

**VCR**

RCA  
877-266-2728  
www.rca.com

**Water Filtration**

Hydro Life  
800-626-7130  
www.hydrolife.com

**Water Heater**

Atwood Mobile Products  
800-873-4328  
www.atwoodmobile.com

**Washer/Dryer (Optional)**

Splendide  
503-655-2563  
www.splendide.com

**Water Pump**

Shurflo  
800-854-3218  
www.shurflo.com

**Wheels - Aluminum**

Accuride  
800-626-7096  
www accuridecorp.com

**Windshield Wipers**

Diesel Equipment  
336-373-8331  
www.diesequipment.com

**MANUAL ADDENDUMS**

[www.monaco-online.com](http://www.monaco-online.com)

Click **ENTER** to enter the main web page.  
Then click on the **SERVICE** link and choose  
**MANUAL ADDENDUMS** from the drop down menu.

**TECH TIPS**

*FIND CURRENT AND ARCHIVED TECH TIPS WITH  
ANSWERS TO  
FREQUENTLY ASKED QUESTIONS AT:*

[WWW.MONACO-ONLINE.COM](http://www.monaco-online.com)

*CLICK ON **ENTER** TO ACCESS THE MAIN WEB PAGE.  
THEN CLICK ON THE **SERVICE** LINK AND CHOOSE  
**TECH TIPS** FROM THE DROP DOWN MENU.*

# Limited Warranty Transfer Application/Change of Owner Information

<b>Mail to:</b>  Monaco Coach Corporation P.O.Box 465 Wakarusa, IN 46573 ATTN: Warranty Registration  Please read terms and representations below before signing.	<b>Submitted By:</b>  Name _____  Address _____  City _____ State _____ Zip _____  Phone _____
--	--

Limited Warranty Transfer

Address Change

## A. Current Owner Information

First Name \_\_\_\_\_ Initial \_\_\_\_\_ Last Name \_\_\_\_\_

Vehicle Identification Number \_\_\_\_\_ Unit # (15 digits) \_\_\_\_\_ Prod/Coach # (6 digits) \_\_\_\_\_

## B. New Owner Information, Transfer Coverage To:

First Name \_\_\_\_\_ Initial \_\_\_\_\_ Last Name \_\_\_\_\_

Phone Number \_\_\_\_\_ Street Address \_\_\_\_\_

Date of Transfer (If Applicable) \_\_\_\_\_ City \_\_\_\_\_ State \_\_\_\_\_ Zip \_\_\_\_\_

Odometer Reading at Transfer (If Applicable) \_\_\_\_\_

## C. Signatures:

(New ) Owner's Signature \_\_\_\_\_ Date \_\_\_\_\_ Selling Dealer's Signature (If Applicable) \_\_\_\_\_ Date \_\_\_\_\_

## Terms & Representations

By your signature(s) on face side of this form, and in order to induce Monaco Coach Corporation to transfer its Limited Warranty, you represent the following:

1. That you have received and read a copy of the Limited Warranty.
2. You understand that the unit is to be used only for family camping and cross country travel on improved roads.
3. All information provided by you on face side of this form is true and correct.
4. You understand that you are purchasing a pre-owned recreational vehicle and Monaco Coach Corporation does not make any representation as to its present condition.









# Driving & Safety

## Section 2

<b>DRIVING &amp; SAFETY</b> .....	<b>33</b>	<b>VIEWS</b> .....	<b>84</b>
Inspections.....	33	Front .....	84
Familiarize Yourself .....	33	Rear .....	84
Velvac Mirror.....	33	Roadside.....	85
Ramco Mirror (Opt) .....	35	Curbside .....	85
Safety Seat Belts .....	36	<b>SMOKE DETECTOR</b> .....	<b>86</b>
Driving Tips .....	39	Operation .....	86
<b>PRE-TRIP PREPARATIONS - CHECKLIST</b> .....	<b>44</b>	Testing .....	86
<b>HITCH</b> .....	<b>47</b>	Maintenance.....	87
Using the Rear Receiver .....	47	Troubleshooting.....	87
Tow Plug Connection.....	48	<b>LP-GAS DETECTOR</b> .....	<b>88</b>
<b>REAR VIEW SYSTEM</b> .....	<b>49</b>	Testing .....	89
<b>REAR, CURBSIDE &amp; ROADSIDE VIEW SYSTEM (OPT)</b> ..	<b>49</b>	Alarm .....	89
<b>BACKING UP A MOTORHOME</b> .....	<b>50</b>	Maintenance.....	90
<b>SET-UP PROCEDURES - CHECKLIST</b> .....	<b>52</b>	<b>CARBON MONOXIDE DETECTOR</b> .....	<b>90</b>
<b>DRY CAMPING</b> .....	<b>54</b>	Operation .....	91
<b>BREAKING CAMP</b> .....	<b>56</b>	Alarm .....	92
<b>EMERGENCY PROCEDURES - ROADSIDE</b> .....	<b>58</b>	Testing .....	92
Jump Starting.....	58	Cleaning .....	92
<b>TOWING PROCEDURES</b> .....	<b>61</b>	Troubleshooting.....	92
Disabling the Parking Brake .....	62	<b>FIRE EXTINGUISHER</b> .....	<b>93</b>
<b>TIRES</b> .....	<b>63</b>	<b>EGRESS (EXIT) WINDOW</b> .....	<b>94</b>
Importance of Air Pressure.....	63		
Tire Pressure Inflation Guideline.....	64		
Inspecting & Pressure .....	65		
Air Pressure Checklist.....	66		
Supporting When Leveling.....	67		
Tire Vibration .....	68		
Tire Rotation.....	68		
Tread.....	68		
Wheel Mounting .....	69		
Storage of Tires - Long Term .....	70		
<b>WEIGHING THE MOTORHOME</b> .....	<b>71</b>		
Weight Terms .....	71		
Weight Label .....	74		
Four Point Weighing (Example) .....	75		
Cargo Carrying Capacity Flowchart.....	80		
Weight Record Sheet.....	83		





## DRIVING & SAFETY

Section two contains information on driving tips, emergency situations, towing, safety devices, weighing the motorhome and tires.

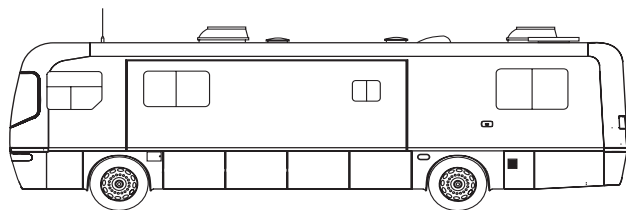

010613

---

### *Inspections*

There are significant differences between a passenger automobile and a motorhome. Always be aware of these differences when traveling. The key to safely operating a motorhome is inspection. Any defect found could result in problems on the road that may cause lost time and money. Several states require that the motorhome be inspected prior to registration. Know and observe the laws of the states in which you will be traveling. Laws may vary from state to state. A systematic inspection conducted prior to moving the motorhome will ensure nothing is overlooked and will assist in familiarizing the owner with the motorhome. Prior to moving the motorhome perform a general **inspection** which includes examining the condition of the vehicle and the surrounding area of the motorhome for hazards. Look high and low when walking around the motorhome.

---

### *Familiarize Yourself*

The location of the driver's seat in the motorhome is higher and farther to the left than most vehicles. This creates a different perspective of the roadway. Rely on the outside mirrors to line up with the center of the road and to check the conditions behind the motorhome. The dashboard may contain more gauges and controls than are normally found in passenger automobiles. Become familiar with these gauges and their indications before starting out.

---

### *Velvac Mirror*

The mirrors will require adjusting before starting out. It is recommended that someone assists with these procedures to prevent damage to the mirror or the coach.

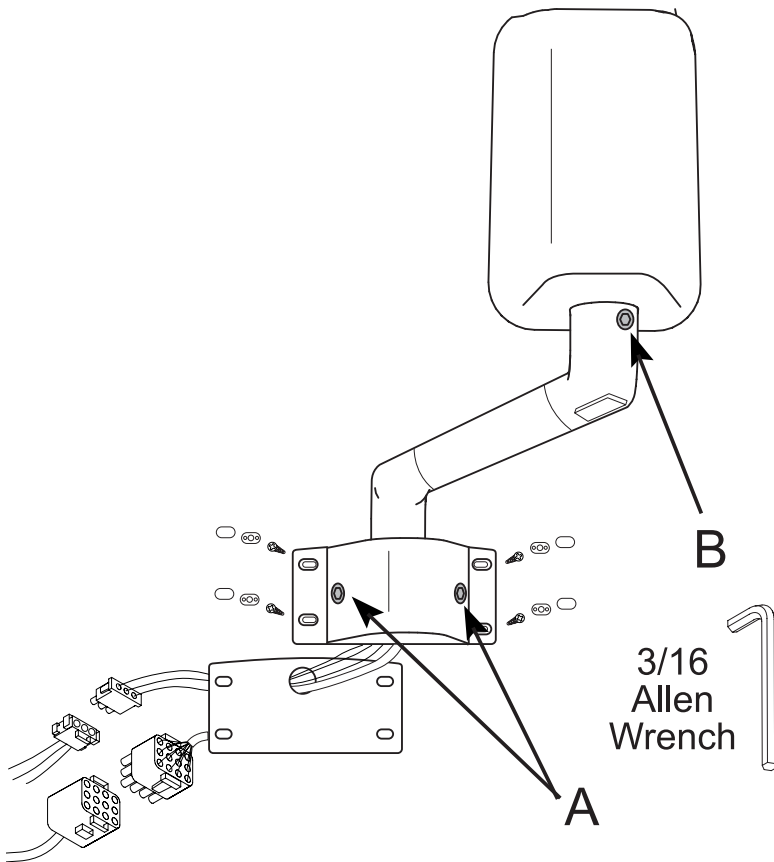

070181 modified

**Mirror Adjusting:**

- Tools needed: Allen wrench.
- Adjust the driver seat to the travel position.
- Using an Allen wrench, have the assistant loosen the two 3/16" Allen set screws located at the base of the mirror. (See point A on the drawing.)
- Adjust the mirror so that there is a clear side view of the coach.
- Tighten the two base screws once the proper adjustments are made.
- To adjust the head of the mirror, loosen the screw located above the turn signal shown on point B. Now adjust the head of the mirror to the left or right.
- Make sure all Allen set screws are tight.
- Repeat procedure for passenger side mirror.

**NOTE:** Use the mirror adjust switch located on the road side console to fine tune the view.

**Mirror Removal:**

- Tools needed: #3 Phillips screw driver, or a #2 Square tip.
- Remove the screw covers carefully.
- Have someone assist in holding the mirror steady. Unscrew the four screws.
- Unplug the 12-wire plug and the 3-wire plug by using the tabs located on the side.

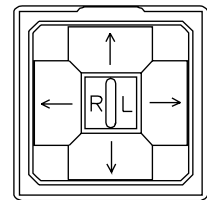

080378

**Mirror Installation:**

- Place the gasket on the back side of the mirror, run the plugs and wires through the hole in the gasket.
- Align index terminals and push plugs together until locking tabs engage.
- While holding the mirror steady, line up the holes.
- Install the screws and screw cover.

**Ramco Mirror (Optional)**

The mirrors will require adjusting before starting out. It is recommended that someone assists with these procedures to prevent damage to the mirror or the coach.

**Mirror Adjusting:**

- Tools needed: Allen wrench and socket wrench.
- Adjust the driver seat to the travel position.
- Using the socket wrench have the assistant loosen the bolt located at the base of the mirror. (See point A on the drawing.)
- Adjust the mirror so that there is a clear side view of the coach.
- Tighten the bolt once the proper adjustment is made.
- To adjust the "head" of the mirror, loosen the set screws located below the mirror shown as point B. Adjust the head of the mirror to the left or right.
- Tighten set screws once the proper adjustment is made.
- Repeat procedure for passenger side mirror.

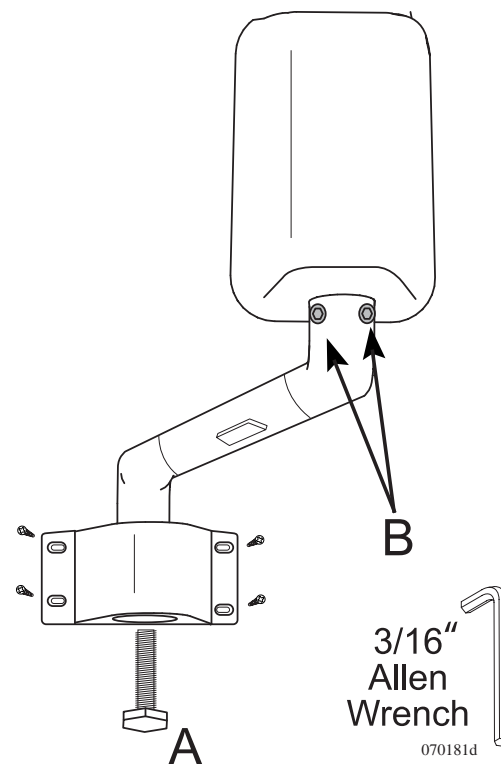

**NOTE:** Use the mirror adjust switch located on the road side console to fine tune the view.

**Mirror Removal:**

- Tools needed: Phillips screw driver.
- Have someone assist in holding the mirror steady. Unscrew the four screws.
- Unplug the wiring and remove mirror.

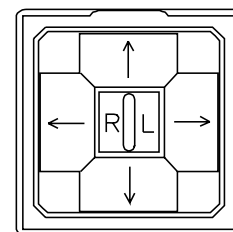

080378

**Mirror Installation:**

- Place the gasket on the back side of the mirror, run the plugs and wires through the hole in the gasket.
- Align index terminals and push plugs together until locking tabs engage.
- While holding the mirror steady, line up the holes.
- Install the screws.

## Safety Seat Belts

All occupants must be furnished with and use seat belts while the motorhome is moving. The driver's seat, and all other seats designed to carry passengers while the motorhome is in motion, are equipped with safety seat belts. Do not occupy beds or any seats that are not equipped with a safety belt while the motorhome is in motion. Safety belts are supplied at affixed seating positions. The driver's seat must be locked in the forward facing position while motorhome is in motion. Do not use a seat belt on more than one person.

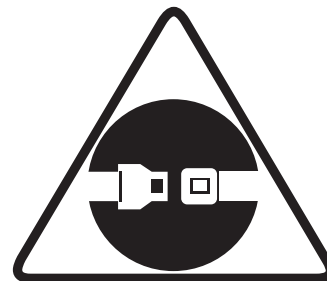

To fasten the seat belt, pull the belt out of the retractors and insert the tab into the buckle; you will hear a click when the tab locks into the buckle. Seat belt lengths automatically adjust to size and sitting position. Do not route belts over armrest.

**WARNING: Safety belts are supplied at affixed seating positions. Do not occupy seats not equipped with safety belts while the motorhome is in motion. Do not use a single seat belt on more than one person. Pilot and Co-pilot seats must be locked in a forward facing position with seat belts fastened while the motorhome is in motion. Avoid seat rotation while in transit.**

**Child Safety Seat:** Children that fit into example 1 and example 2, as shown on the following pages, require the use of a child safety seat. In the motorhome, the child safety seat can be positioned in two places. On the front passenger (co-pilot) seat and on the forward facing permanently mounted booth dinette seat.

**WARNING: Children must not be transported unrestrained. Infants must be placed in approved safety seats. Small children must be restrained in child safety seats. Failure to comply with these rules can lead to injury or death.**

**NOTE: Individual states and Canadian provinces may prohibit use of a safety or booster seat in the front seat.**

**A child safety seat is required for any child:**

- **Infants** - from birth to one year, or up to 21 pounds, the child is considered an infant. A (convertible) safety seat for an infant must be secured facing rearward. The top of the head must be below the top of the safety seat. Secure safety seat harness straps at or below the shoulders. (See **Example 1**).
- **Toddlers** - children over 1 year and over 20 lbs. - 40 lbs. are considered toddlers. A (convertible) safety seat for a child must be secured facing forward. The top of the head must be below the top of the safety seat. Secure safety seat harness straps should be at or above the shoulders. (See **Example 2.**) Most seats require top slot for forward facing.
- **Young Children** - children (ages 4 to 8) over 40 pounds unless over 4' 9" require a booster seat. The booster seat places the child's waist and shoulders at the proper height for the supplied safety belt to be effective. The top of the head must be below the top of the safety seat. (See **Example 2**).

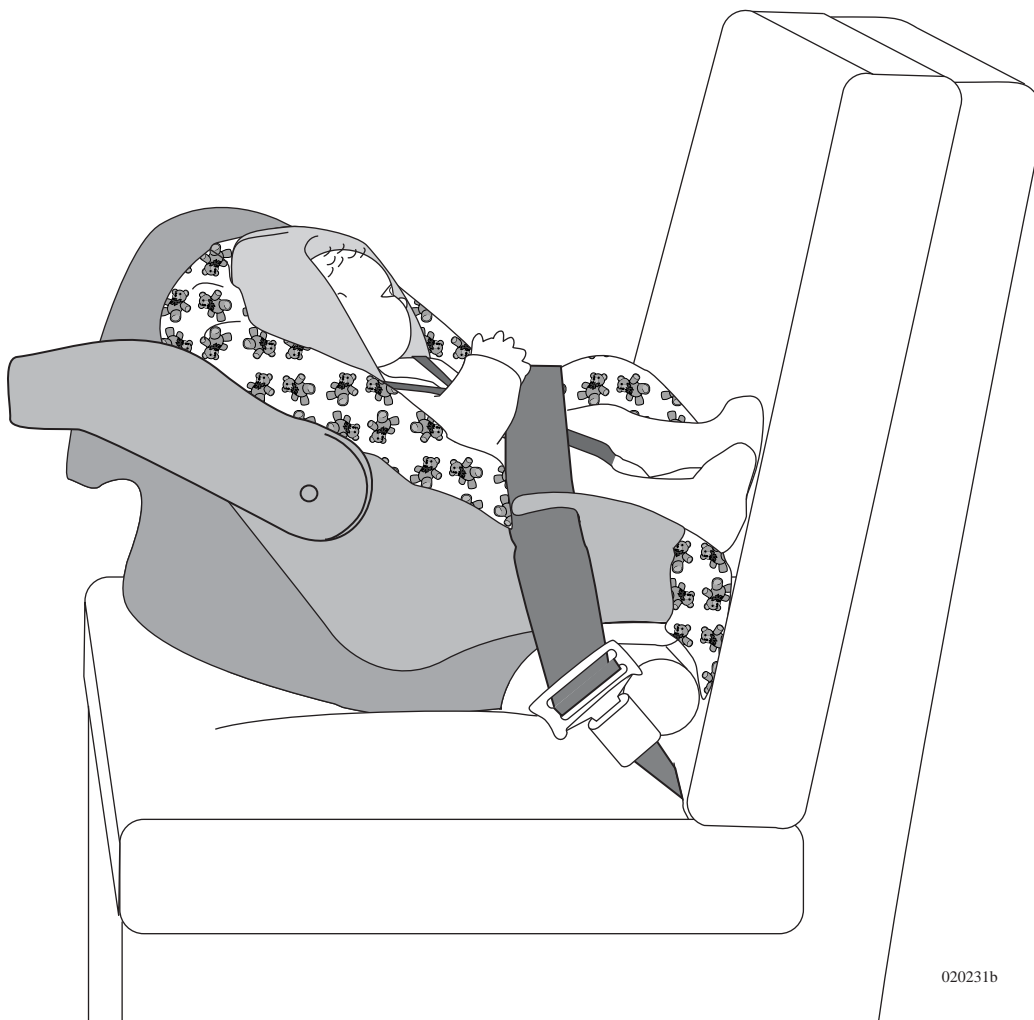

020231b

*Example 1: Convertible Seat Facing to the Rear.*



020230

*Example 2: High back booster seat facing forward.*

**CAUTION:** Installation illustrations are for reference only, and are not to be used as a guide. Refer to the safety seat manufacturer's guide.

**WARNING:** Because there are many styles of safety and booster seats, refer to the manufacturer's manual for proper installation and how to properly secure the safety or booster seat.

**CAUTION:** Seat belts must only be used on permanently mounted seats. Do not use a single seat belt on more than one person.

**NOTE:** Individual states and Canadian provinces may have laws that can exceed the requirements described above. It is your obligation to know and comply with the laws in the state or province in which you travel.

**Seat Belt Care:** Keep the belt clean and dry. To clean, use a mild soap and lukewarm water. Never use bleach, dye or abrasive cleaners as they may weaken the belt. Inspect the belts periodically. Check for cuts, frays or loose parts. Replace any damaged parts. Do not disassemble or modify the system. Replace the belt assembly if it has been in a severe impact, even if damage is not obvious.

### Driving Tips

The motorhome is a complex vehicle and requires an increased level of driving awareness because of its size and various components. Due to the motorhome length the turning radius will be much wider than that of a standard automobile. Always pay close attention to all perimeters of the motorhome: front, sides, rear, roof and undercarriage. Insure the surrounding area is clear of obstacles. Utilize the driving mirrors to observe traffic conditions as well as the motorhome exterior: tires, bay doors, blind spots, etc. Use a push-pull method of steering, with both hands parallel on the steering wheel. The motorhome is also heavier than an automobile with a higher center of gravity. These factors affect the reaction time of the motorhome. Swerves and sharp turns, especially performed at high speeds, could result in the loss of control of the motorhome. Keep the size of the motorhome in mind and drive with extra caution to avoid situations which might require quick momentum changes. Increase reaction time by paying attention to traffic and road conditions 12-15 seconds ahead of the motorhome's position.



The motorhome will travel safely and comfortably at highway speed limits. However, it takes more time to reach highway speed. When passing another vehicle, allow extra time and space to complete the pass due to the added length of the motorhome. When descending a long hill, use the exhaust or engine brake. The transmission and engine will help control downhill speed and can extend the service life of the brake lining. The distance required to stop the motorhome is greater than an automobile. The brakes are designed for the (GVWR) Gross Vehicle Weight Rating. Practice stopping away from traffic to get the "feel" of the distance required to stop the motorhome.

When backing up, have the co-pilot stand at the road side rear corner so the co-pilot remains visible in the roadside mirror. The co-pilot can watch for any obstacles and give hand signals during the backing up process.

When traveling, make sure bridges being crossed can support the weight of the motorhome. Check the tonnage limit of the bridges before crossing them. Signs should be posted at bridge entrances. Check the posted height of all overpasses or situations where overhead clearance is limited. Keep in mind, road surfaces may have been repaved or become packed with snow and therefore the actual posted clearance height would not apply in such conditions.

**Driving Cautions:**

- Avoid getting too close to the edge of the road, a soft shoulder may not support the weight of the motorhome.
- Side spacing is best maintained by keeping the motorhome centered in the driving lane.
- Driving lanes in work zones can be uneven, congested and more narrow than usual.
- Be cautious of road debris which can damage the undercarriage of the motorhome or become lodged in the dual tires causing damage to the tires, wheel rims or tow car.
- Keep in consideration that posted speed signs are passenger automobile rated. Therefore, an extra awareness of the driving conditions and appropriate speed for a motorhome are necessary, especially on corners and mountain roads.
- Downgrade speed should be at least 5 mph less than upgrade speed, or downgrade speed should be attainable within three seconds of a brake application.
- Use a four second rule when following other vehicles at speeds under 40 mph. Use a five second rule when following at speeds over 40 mph.

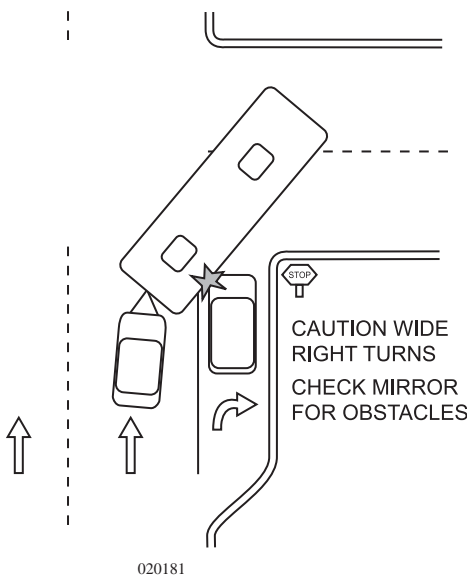

**Right Turns:** Negotiating a right hand turn in a motorhome can be difficult. Many drivers fear they can not make the turn without entering into the other lane or jumping the curb. Here are a few tips to make a right hand turn easier:

- As the turn approaches, look into the mirror to ensure the lane to the left is clear, then move wide over to the left.
- When you are about to make the turn; the left rear wheel should touch the center line of the road and your hips should be parallel to the roadside curb of the corner being turned. This will aid in avoiding a premature turn.
- Make the turn slowly.
- Check mirrors frequently, being aware of necessary clearance and space management of the motorhome, while negotiating the turn.

**Left Turns:**

- Do not start the turn until the center of the intersection is reached with your hips. If there are two lanes available, take the right hand lane. A car or driver on the left hand side is easier seen.



**Ascending a Grade:** When approaching an uphill grade, try to assess how steep and long it is before beginning to climb. Prepare early for long climbs.

Unlike gasoline engines, diesels do not necessarily produce more power by pressing further on the accelerator! A gasoline engine will happily work at full throttle (at least for a short period of time), but a diesel usually just wastes fuel at full throttle. The power output from a diesel engine is dependent upon the following:

- **RPM** - Every engine has a range of RPM where it produces power most efficiently.
- **Fuel/Air mixture** - At a given RPM, an engine, even with the help of a turbo-charger, can only "pump" a given volume of air into the combustion chamber. This volume of air can combine with only so much fuel efficiently; so it follows logically that feeding more fuel to the fire will simply waste fuel.

Determine the ranges where the motorhome works best by driving long grades in a way that temperatures will remain stable for the duration of the climb.

**IMPORTANT SAFETY TIP:** If the road speed degrades to the point where the motorhome is moving significantly below the posted speed, turn on the four way flashers. Take advantage of pullouts if traffic is building. Once in the pullout, if there is sufficient clearance for safety, take a break. Idle the engine to allow the exhaust and the turbo to cool. While these are cooling, the transmission also cools. Monitor the gauges and enjoy the view while you wait.

**Descending a Grade:** When descending a long grade, use the braking force of the engine and the auxiliary braking device (i.e. the Jake Brake or exhaust Pac Brake) to maintain a safe, slow speed. Do not rely entirely on the service brakes to slow the motorhome when descending long grades. Pumping and riding the service brakes is not recommended when descending a grade, as the brakes can overheat. Over-use can result in the loss of brake effectiveness.

If it is necessary to use the service brakes for additional braking, use moderately heavy pressure on the brake pedal to reduce the motorhome speed to the desired speed of travel, then release it.

Before descending a grade, downshift the transmission to a lower gear and use the engine to slow the vehicle. Monitor the motorhome speed while descending the grade.

If the motorhome begins to accelerate while proceeding down the grade, or it becomes necessary to slow the motorhome, activate the auxiliary braking device.



**Night Driving:**

- As always be well rested and alert when driving. If necessary, find a safe stopping place to rest until ready to continue.
- Avoid using any interior lights while driving. They can create a glare on the windshield, decreasing visibility.
- Dim the dash lights to a comfortable level to reduce the level of glare.

**Extreme Heat and Hot Weather Conditions:**

- Observe all gauges frequently. Any variations from the normal conditions should be evaluated promptly.
- Check tire pressure before traveling in hot conditions. Tire air pressure increases with heat. It is not advisable to let air out of a hot tire. When the tires cool down they will return to the correct/previous tire pressure.
- Pay extra attention to hoses and belts which are more susceptible to fatigue in extreme heat.

**Winter and Cold Climate Conditions:**

- The motorhome should be prepared for Cold Weather Use.
- Keep speeds slow and steady. Make moves gradually and increase visual distance for a gain in reaction time.
- If road or weather conditions are treacherous find a safe stopping place and wait for conditions to improve.
- Avoid using an engine retarding device on wet or slippery surfaces, which can cause the drive wheels to skid.
- Wipers should be in good condition and the washer reservoir should have sufficient window wash fluid that has antifreeze included within it.
- Use the mirror heat to keep the mirrors clear.
- Remove any ice build-up from the entry step to avoid accidental slipping.

**Wet Conditions:**

- The risk of hydroplaning is increased if tires are worn or improperly inflated.
- Be aware that heavy rain or deep standing water can affect brake application causing them to apply unevenly or grab.

**Fuel Economy:** Many factors contribute to the amount of fuel consumed during driving. Driving styles, wind resistance, terrain, vehicle weight, and engine-driven accessories are some of the factors that affect the fuel economy.

**Guidelines to Help Increase Fuel Efficiency:**

- When starting out, apply the throttle lightly and accelerate gradually, avoid using excessive throttle and accelerating quickly.
- Check the tire pressure. A low tire is not only a safety hazard, it also increases rolling resistance which increases fuel consumption.

- While operating the motorhome, keep the engine at a low to mid operating range of 1100 to 1500 RPM. This will use less fuel than operating at higher RPM.
- Avoid using full throttle when ascending a long hill. This wastes fuel and increases engine operating temperature from incomplete combustion. Manually downshift to a lower gear and use less throttle. Fuel will burn more efficiently.
- Avoid extended idling to "warm-up" the engine. Start the engine and wait long enough for normal oil pressure to register. Engage the high idle feature until the engine coolant temperature gauge rises. The engine is now ready for travel. Whenever coolant temperature is below 160° F (as in an idling engine) incomplete combustion occurs. This causes carbon buildup and raw fuel will wash the lubricating oil from the cylinder walls diluting the crankcase oil.
- Excessive idling (more than 15 or 20 minutes) can clog fuel injectors and may eventually cause piston rings and valves to stick.
- Operate the transmission with the **MODE** function set to **Economy** whenever possible; this allows for earlier shifts and enhanced fuel economy.
- Follow the maintenance schedule for the engine, transmission and chassis. Proper maintenance will lead to enhanced fuel economy, motorhome performance, and overall longevity.

**Refueling:**

- Truck stops are good refueling points for motorhomes.
- Know which side the fuel port is on. There may not be adequate space to turn around in the parking lot to reposition for the pump.
- Check overhead clearance heights before pulling through the fuel island.
- Be aware of the concrete/steel posts installed around the fuel island.
- Avoid running over the fuel hose as it can get hung up on the motorhome, causing body damage.
- Use of gloves is recommended for refueling. Store the gloves in the outside compartment.
- To prevent grease and fuel deposits from being tracked into the motorhome when refueling, change shoes before entering the motorhome. Store the extra pair near the entry door.

**WARNING: Avoid the risk of fire or explosion. Turn off all pilot lights and appliances before entering a refueling station.**

## PRE-TRIP PREPARATIONS - CHECKLIST

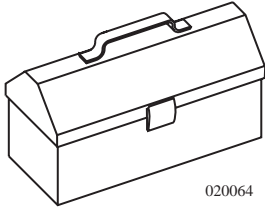

The following list highlights items that need to be checked on the motorhome before traveling. Prior to departing several items will need to be prepared. Some suggestions are listed below. Use the lists as general guidelines when preparing to depart. By doing so, there is a better chance of not facing problems during the trip. For chassis maintenance details, please refer to the chassis section.

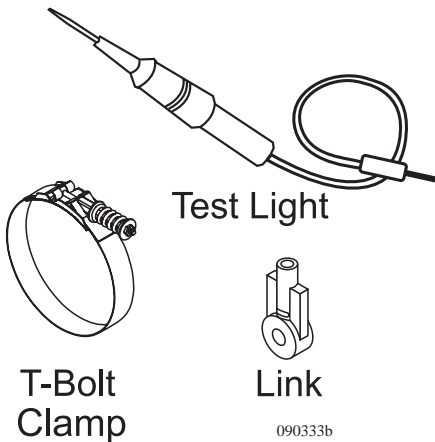

### Items To Carry:

- Local, State and National Maps. Truck atlases can be useful for showing maps, refueling stations and truck repair facilities.
- An emergency road kit containing a flashlight, road flares, warning signs and a fire extinguisher.
- Potable/non-potable water hoses and a water pressure regulator.
- Hand tools.
- 12 Volt DC test light and a 110 AC Polarity Tester. These may be helpful when on the phone with a technician.
- A battery hydrometer to check the condition of battery electrolyte.
- A spare 12 Volt DC continuous duty solenoid (if applicable).
- An assortment of spare fuses.
- A link kit for ride height control assembly (air suspension only).
- A spare alternator serpentine belt.
- Charge air cooler T-bolt clamp.



### Interior Items:

- Start refrigerator operation the night before departure to get a head start on the cooling process. Pre-cool items prior to loading the refrigerator.
- If necessary, load pots, pans, utensils, soap, linens, etc.
- Secure and fasten the bi-fold and pocket doors. Lock the shower door.
- Close roof vents and windows.
- Secure any loose, heavy or sharp objects in case of a sudden stop.
- Close all cabinet doors and drawers.
- Walk the interior and check for items not secured.
- Test the appliances before leaving home.
- Turn interior lighting off.

**Exterior Items:**

- Check operation of all exterior lights, headlamps, taillights, brake and clearance lights.
- Check the battery fluid level of Liquid Lead Acid batteries.
- Check all fluid levels on the chassis and generator. (See **Chassis Information** section and the generator manual for details.)
- Check the fuel/water separator in the engine service compartment. Clean and drain if needed.
- Adjust the mirrors.
- Check the windshield wipers.
- Fill the LP-Gas tank.
- Test the generator.
- Make sure the following items are in the motorhome: sewer connection hose, water fill hose, awning rod and electrical adapters.

**Engine Checklist:**

- **Inspect** the engine, transmission and engine compartment for fluid leaks.
- **Inspect** the area under the motorhome for fluid leaks or puddles.
- Check all fluid levels, oil, antifreeze, transmission, hydraulic fluid and washer fluid.
- **Inspect** belts and hoses for wear.
- **Inspect** wiring for loose, frayed or corroded connections.
- Start engine and listen for any unusual noises.

**Driving Preparations:**

- **Inspect** fluid level (if applicable) in oil bath hubs.
- Fill the water tank and make sure the waste tanks are empty. Test the water pump.
- Disconnect and store the fresh water hose (if applicable).
- Check all tire pressures.
- **Inspect** tires for cuts, punctures, weather damage or cracks in the sidewalls and tread areas.
- Check for foreign objects lodged between dual tires.
- Make sure all lug nuts are tight. This should be done by an approved repair facility.
- Secure all awning locks.
- Check storage bays to prevent shifting or damage to items.
- Outside compartment doors should be closed and locked.
- Look around, above and under the motorhome for obstructions.
- Check fuel level gauge. Fill the fuel tank if necessary.
- Check all other dash gauges for operation and correct level indications.
- Secure and lock the entry door for travel.

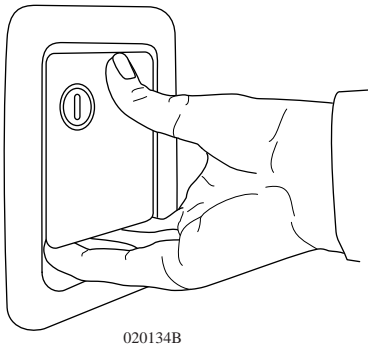

**Storing Cargo:** Caution must be exercised when opening the bay doors as cargo may shift during traveling. When closing the bay doors, be sure to keep fingers away from the openings. When opening the bay doors, use thumb at position shown while opening. Cargo may shift while driving. Push on bottom of door to relieve tension on lock.

**WARNING:** To avoid injury, never place your hands or fingers near the top of the bay door when opening or closing. Always use the latch handle. Apply pressure with the other hand just above the latch handle.

It is important to remember that regardless of how large the motorhome, there is a limit to storage capacity. Pack as lightly as possible to allow for additional storage during the trip. It is often easier to purchase needed items at the final destination rather than to discard items to make room for additional cargo.

While packing the motorhome, keep two things in mind, turning and braking. For the motorhome to handle well, the load will need to be evenly distributed side-to-side and front-to-back. Additionally, heavy items should be stored as low as possible to keep the motorhome from becoming top heavy. Make sure that everything is secure and safe from quick turns, bumps and sudden stops.

**TIP:** Multi-purpose items, versatile clothing and periodic removal of unused cargo enables storage of more of what is usually used.

**Guidelines for Loading the Motorhome:**

- Distribute the cargo weight evenly from side-to-side and front-to-back. This practice will prevent both handling problems and uneven stress on the components throughout the life of the motorhome.
- Heavy items should be stored near the rear axle, lighter items stored toward the front.
- To maintain a low center of gravity and reduce sway, store light items in the overhead cabinets and heavier items near the floor.
- Secure loose items to prevent weight shifts that could affect the balance of the motorhome.

**HITCH - Using the Rear Receiver**

When using the rear hitch receiver, remember that the motorhome is intended for towing light loads and is primarily designed as a recreational vehicle. Safety and durability of the hitch receiver requires that the receiver be properly used. Avoid excessive towing loads or other misuse of the receiver. Towing will affect fuel economy. Weight pushing down on the rear hitch must not exceed 10% of the hitch capacity. It is recommended to weigh the motorhome when fully loaded to ensure proper weight distribution of the GCVW (Gross Combined Vehicle Weight). When weighing the motorhome add all passenger weight to GCVW total. The motorhome fully loaded, including fresh water and LP-Gas and any vehicle or trailer towed by it, must not exceed GCVW.

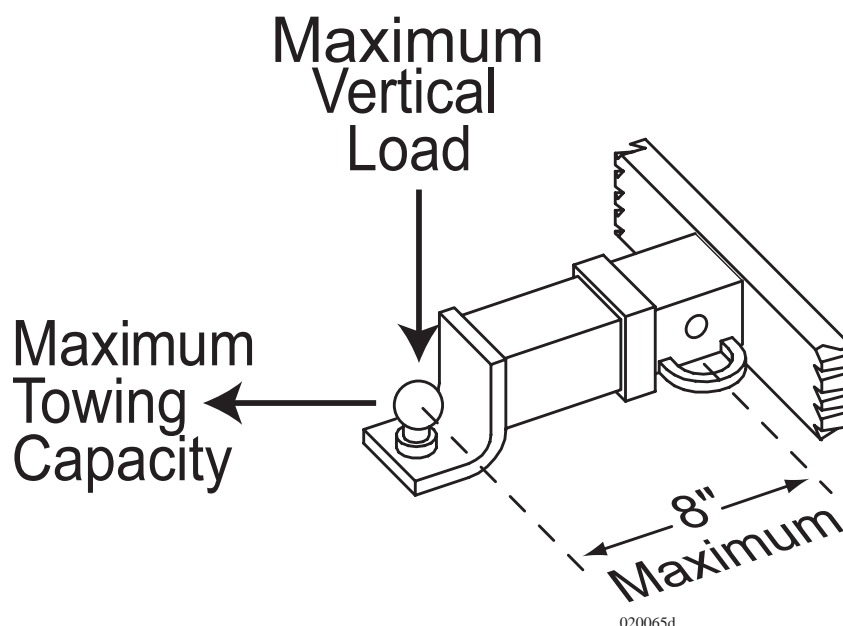

**WARNING: Most states and Canadian provinces require any trailer or vehicle being towed have adequate brakes. Failure to comply these State and Canadian province requirements may result in fines and/or pose a safety hazard, which may result in an accident.**

 <p><b>MONACO</b> COACH CORPORATION</p> <p>Coburg, Oregon Springfield, Oregon Wakarusa, Indiana Elkhart, Indiana</p>	<p><b>Do Not Cut, Weld or Modify</b></p> <p><b>Do Not Exceed Vehicle Ratings</b></p>
	<p><b>Maximum Towing Capacity</b> 10,000 lbs. (4,536 Kg.)</p>
	<p><b>Maximum vertical Load</b> 1,000 Lbs. (454 Kg.)</p>
	<p>Any Towed Vehicle or Trailer Over 1000 lbs. (450 kg) Should Have Separate Functioning Brake System</p>

020144d



**WARNING: Do not tow a trailer or vehicle that exceeds the rated capacity of the hitch receiver. Overloading the hitch receiver can cause unusual handling characteristics and overstress the hitch receiver and chassis. It could also void the warranty. If there are any questions, call a factory technician.**

**Tow Car or Trailer:**

1. Connect a tow car or trailer to the motorhome with safety chains rated for the weight of the load.
2. Make the electrical connection and perform a light check before starting each trip and at each rest stop.
3. Check the tire frequently. Flat tires on a towed vehicle cannot be detected from the motorhome while driving. A flat tire is a safety hazard and may cause extensive damage.

**WARNING: Be sure the weight ratings of the ball mount, tow ball and safety chains are equal to or greater than the load. The use of an extension to the receiver or extended ball mount will significantly reduce hitch receiver ratings. Modifications to the hitch receiver or use of the hitch receiver other than intended can void the warranty of the hitch receiver, chassis or both.**

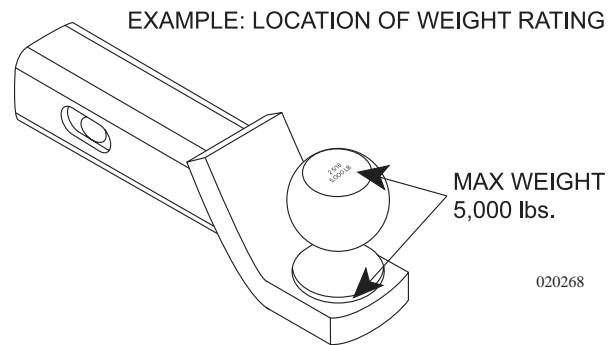

**Tow Plug Connection**

The motorhome is pre-wired from the factory with an electrical connection for towing, located on or near the hitch receiver. Convuluted tubing protects the tow harness wires. Current draw should not exceed ten amps for each designated light circuit.

**The tow harness wires are color-coded:**

- Yellow, 14 gauge - Back Up
- White, 10 gauge - Ground
- Brown, 14 gauge - Right Turn Signal
- Red, 14 gauge - Left Turn Signal
- Green, 14 gauge - Marker Lights

When preparing a tow plug connection strip the wires 3/8". Twist the wire strands and place under the clip and secure the screw. Make sure there are no loose strands of wire that could short against the case or other terminals. Do not accidentally mirror image the trailer connection.

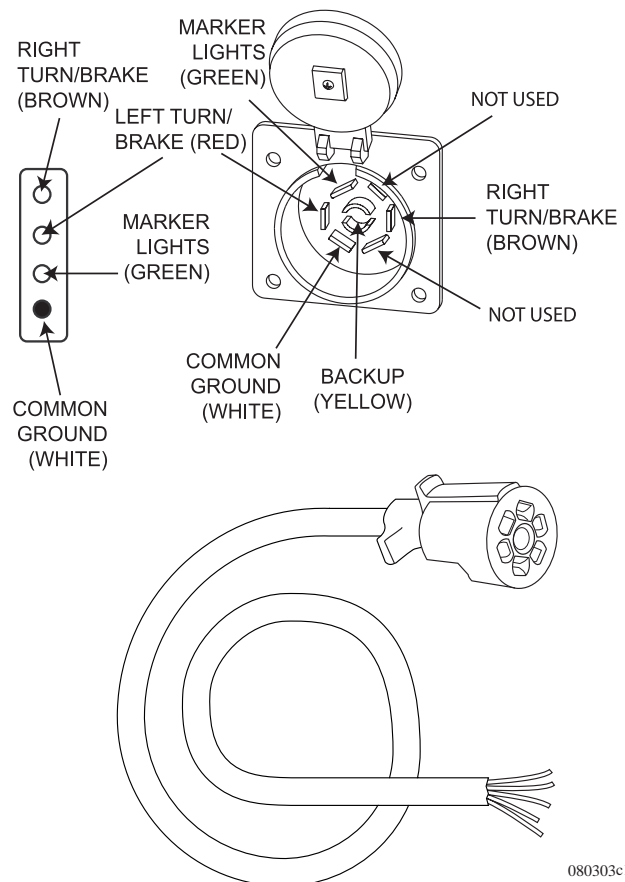



## REAR VIEW SYSTEM

The motorhome is equipped with a rear vision and voice system. The rear vision system consists of an adjustable camera with a microphone and a dash mounted monitor. This allows the driver to see what is behind the motorhome and listen to verbal guidance.

**NOTE:** The rear vision system will automatically turn ON when the gear selector is placed in reverse.

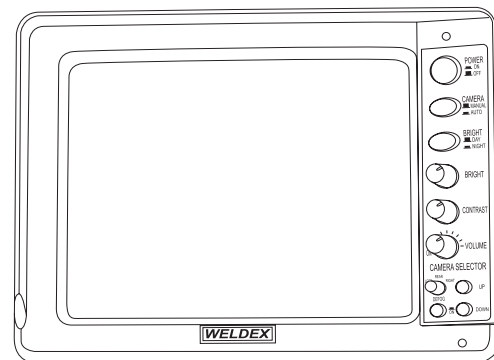

031156

### Monitor Features:

- **Power ON/OFF** button: Turning the main power switch ON will allow continuous operation of the rear vision system while the ignition key is ON.
- **Camera Manual/Auto** button: (Optional three camera system only.) With the button in the Manual (out) position, any of the three cameras can be selected with the red toggle switch at the bottom of the monitor. With the button in the Auto (in) position, the camera will automatically change views with blinker activation. This also works when reverse is the selected gear.
- **Day/Night** button: Set camera for better picture in varying light conditions.
- **Contrast** and **Brightness** knobs.
- **Volume** control knob.
- **Camera Select** switch: Keep switch in the "Rear" position to adjust camera angle.
- **Up** and **Down** buttons: To adjust rear camera angle. Optional Side cameras are not adjustable.
- **Defog** button: Works for rear camera only. Defog turns off automatically after a preset temperature is reached.

**INFORMATION:** For more detailed instructions, see the manufacturer's manual.

## REAR, CURBSIDE & ROADSIDE VIEW SYSTEM (OPTIONAL)

The motorhome can be equipped with a three camera vision system designed to provide the driver with a rear view as well as roadside and curbside views of the motorhome. The rear camera is adjustable up and down and includes a lens defogger controlled by the driver and a microphone to aid in backing up communication. The side cameras are located at the front of the motorhome directly above the front wheels and are not adjustable.

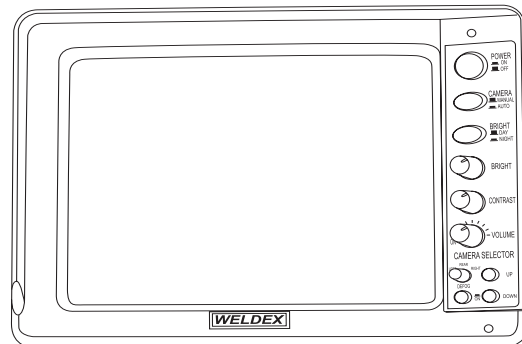
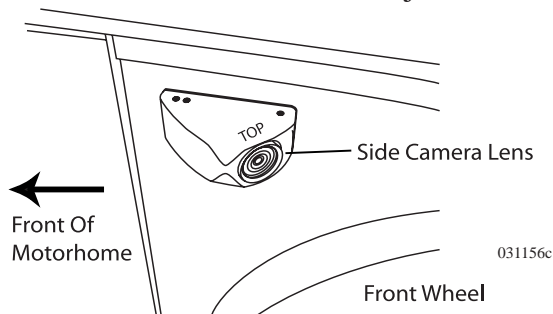

0311056

**Function of Features:**

- **ON/OFF POWER BUTTON** - Press this button to turn the unit ON or OFF. Turning the unit ON will allow continuous operation of the rear vision system when ignition key is on.
- **MANUAL/AUTO CAMERA BUTTON** - With the button in the manual (out) position, either of the three cameras can be viewed by moving the Camera Selector Knob at the bottom of the monitor to the corresponding camera. With the button in the auto (in) position the camera will automatically change views with blinker activation.
- **DAY/NIGHT BRIGHT BUTTON** - Press this button to change setting for daylight or nighttime driving conditions.
- **BRIGHT KNOB** - Turn this knob to adjust monitor brightness.
- **CONTRAST KNOB** - Turn this knob to adjust monitor contrast.
- **VOLUME KNOB** - Turn knob to adjust rear microphone volume.
- **LEFT, REAR OR RIGHT CAMERA SELECTOR KNOB** - Turn this knob to manually select desired camera.
- **UP/DOWN CAMERA SELECT BUTTONS** - Place the camera selector knob in rear camera position and press up or down button to adjust the rear camera.
- **DEFOG CAMERA SELECT BUTTON** - Place the camera selector knob in rear camera position and press this button to turn defogger ON or OFF.

---

## **BACKING UP A MOTORHOME**

Whether you are a long time owner of recreational vehicles or just starting out, backing up can be a challenge. Following some simple guidelines may help reduce the challenge. When backing up, the driver (pilot) should be comfortable using the mirrors, the back-up camera and the co-pilot's directions (ground guide) for assistance. Practice first, backing up with the co-pilot's guidance in a large unobstructed parking lot. Backing up is a team effort.

The backing up process should begin while the motorhome is in forward motion. Maneuver the motorhome to align with the chosen site. This allows straight alignment with the site. Aligning the motorhome with the site after the backing process begins will require considerably more room than an automobile, and may require more than one attempt. When the motorhome is properly aligned with the site, the parking area will be visible in both mirrors. Use straight lines, such as road markings, as reference points when possible.

If the destination does not have “pull-through” sites, try to pick a solid, level site. If possible, pick a site located on the left side. This is the preferred side. The driver will have a better field of vision by using the roadside mirror. If the site is on the right side, the driver will have to use the curbside mirror for backing up, which leaves a blind spot. When a potential site is spotted, stop the motorhome before the site. Get out and observe the area for soft ground, posts, large rocks, low hanging limbs or other obstacles. If the site meets the particular criteria, prepare to back in carefully. Have the co-pilot provide guidance using the five hand signals.

The co-pilot will perform just as importantly as the driver. When guiding the driver, the co-pilot should be located safely at the left rear corner of the motorhome, facing forward, while remaining visible in the roadside mirror at all times. The co-pilot should make a conscious effort to maintain sight of the driver through the roadside mirror as the front of the motorhome maneuvers.

If the driver loses sight of the co-pilot, stop the backing up process until the co-pilot returns to view. To avoid mishaps, the co-pilot should be focused only on what the driver is doing, with brief observation moments. The driver should receive directions only from the co-pilot. If necessary, stop the backing up process to have co-pilot inspect other areas or angles of concern. Use of walkie-talkies will aid in guidance.

When the co-pilot is guiding the driver, only five clearly defined signals should be used, with only one signal given at a time. Flailing arms with indecisive signals only confuse the driver. Signals should be given with purpose and confidence. Directional signals are directing travel of the rear of the motorhome.

If the desired direction is left, the co-pilot points left. For example: The co-pilot will use his/her right arm and forefinger pointing distinctly left with arm and finger held on a horizontal plane, indicating desired direction of travel of the rear of the motorhome. This type of directional signal is easily discerned in the mirror by the driver. The directional signal given will remain steady until desired movement is completed.

#### The five directional signals are as follows:

1. Co-pilot uses left hand and arm held horizontal, with forefinger pointing right, to direct rear of motorhome to the right.
2. Co-pilot uses right hand and arm held horizontal, with forefinger pointing left, to direct rear of motorhome to the left.
3. Co-pilot uses both arms and hands parallel with thumbs pointing up and to rear in a waving vertical motion. This signals driver to maintain a straight back direction.
4. Co-pilot holds arms horizontally, hands open with palms facing one another. Start with a wide separation, gradually closing distance of hands, in a rate appropriate to vehicle speed, to indicate amount of distance to the stop point.
5. Closed fists indicate STOP.

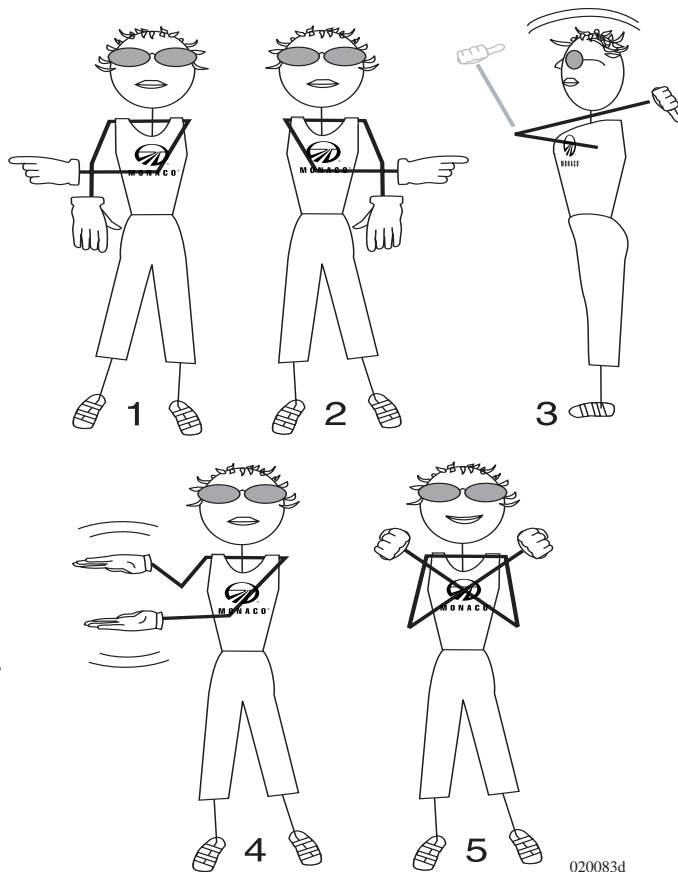

020083d

**Towed Vehicles:** Towed vehicles using a tow bar or tow dolly have more than one pivoting point which makes this type of equipment not suitable for backing. If using this type of towing equipment, plan ahead. Park safely along the road and walk a distance, if necessary, to avoid a possible back up situation. Avoid putting the motorhome and tow vehicle in a backing situation. To back up this combination, completely disconnect the tow vehicle from motorhome. Trying to back up the motorhome with a tow vehicle connected will result in damage to the motorhome, tow vehicle and towing device.

**CAUTION: Tow bars or car dollies generally are made to travel in a forward direction only. Most towing equipment of this type is not designed for backing. Never attempt short back up distances with a tow bar or tow dolly. Damage to the motorhome, vehicle or towing device will result.**

**Backing Up Trailers:** The same rules for backing a motorhome may be applied when backing a trailer. When preparing to back a trailer into a space, maneuver the motorhome sweeping wide, then turn back to the opposite direction. This sets the motorhome and trailer in a position to maneuver the trailer into the space. When backing up a trailer, the driver may become disoriented with the direction of the steering wheel in relation to the direction of the trailer. The bottom of the steering wheel must be moved in the desired direction of the trailer. For example: If the desired direction of the trailer is left, rotate the bottom of the steering wheel left. If the trailer moves in an undesired direction, use a short “pull-up” method, pulling forward just far enough to align the trailer with the space. The co-pilot should stand safely at the left rear corner of the trailer within view of the driver in the roadside mirror, using the five hand signals for guiding.

---

## SET-UP PROCEDURES- CHECKLIST

If the site for the motorhome has full hook-ups, use this quick reference hook-up checklist. This hook-up list is only a guide. This checklist has information on hooking up the utilities and preparing the appliances for use. Specific information on the slide room, awning and leveling system operations is discussed in detail in other sections.

- If applicable, unlock any travel locks which may be securing the slide room. Check for lateral clearance before extending the slide-out room.

**NOTE: To operate any slide room: The ignition must be OFF and the park brake must be set.**

- Follow the procedures and guidelines for “Leveling the Motorhome.” If the motorhome is equipped with hydraulic jacks, be certain the parking surface will accommodate the weight placed on the jacks.

**CAUTION: Before leveling the motorhome survey the area around and under the motorhome for obstructions which can damage the motorhome or undercarriage components when the air bags are deflated.**

**CAUTION:** Hot asphalt may not support the weight that is placed on the hydraulic jack pads. Place thick plywood under the jack pads to help disperse the weight. Never use the leveling system to support the entire weight of the motorhome. Damage from excessive torsional twists can result.

- Open the LP-Gas tank primary valve.
- If possible, begin appliance operation on LP-Gas for the first 60 minutes. Switch the refrigerator operation to gas, start the water heater and furnace (if needed). This will allow time for the inverter to stabilize the battery charging.
- Prepare the shore cord to be plugged in. Extend and inspect the cord. Perform any necessary cord maintenance. Install proper electrical adapters if anything other than 50 Amp service is provided. Turn shore power circuit breaker OFF prior to plugging in the shore cord. Operate electrical appliances in sequence when hooked to a limited shore power service.

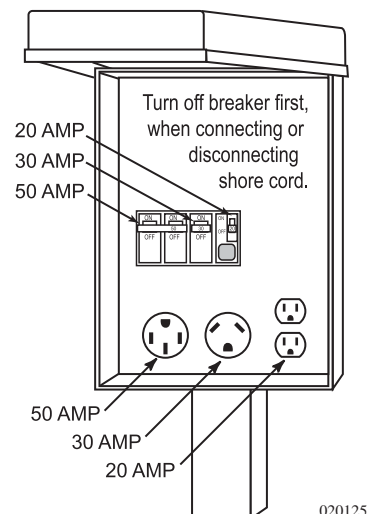

**CAUTION:** If shore power service is limited to 15 or 20 Amps, use of light duty extension cords and electrical adapters will create a voltage loss through the cord and at each electrical connection. Line voltage loss and the resistance at each electrical connection can be a hazardous combination. Damage to sensitive electronic equipment may result!

**CAUTION:** Do not remove cover from shore power supply to troubleshoot electricity to the motorhome. Serious personal injury or death may occur. If there is no power to the motorhome inform the park manager. It is the park manager's responsibility to fix any problems with the park's shore hook up.

- If cable service is provided, hook-up a 75 Ohm RG59 or RG6 cable to the cable connection in the service center. If the motorhome has a video selector box, press the appropriate viewing button for the item desired.
- A phone connection port is provided in the service center. Phone utility outlets are placed throughout the motorhome, including a phone line attached to the satellite receiver for Pay-Per-View movies and events.
- Hook the water hose to the water source. Use a hose labeled potable water or optional reel hose. If the motorhome does not have an optional hose reel, make sure to use the supplied pressure regulator at the city water hose connection. Arrow on the regulator must be pointed toward valve. Turn water valve to "City Water" and turn water on at the water source.
- Hook-up the sewer hose. Sewer drain pipe diameters are generally either three or four inches. Proper sewer hose adapters will ensure against leaks or spillage. Check to make sure all hose clamps are tight, with the sewer hose properly connected open the grey water valve. The black water valve remains closed until the tank is full or until time of departure.

## DRY CAMPING

Plan ahead and conserve resources while dry camping. Dry camping requires fully charged and properly maintained batteries (corrosion cleaned, terminals tightened, cables checked, etc.). If water levels in liquid lead acid batteries are low, fill the batteries with distilled water only. (Tap Water containing a high concentration of minerals will alter battery chemistry, reducing capacity, performance and longevity.)

Begin with a full fresh water tank. Remember to fill the hot water tank before topping off the fresh water supply. Confirm that waste holding tanks are empty. When water supplies run low, evacuate waste holding tanks prior to refilling the fresh water tank.

Solar panels are a valuable addition for battery charging. The motorhome may be equipped with one optional solar panel to help offset parasitic load. Adding up to five panels, will help charge the motorhome house batteries during daylight hours. Clean solar panels regularly for optimum performance using window cleaner and a soft cloth.

Confirm that the location you intend to visit can accommodate the size and length of your motorhome. Drive-through sites are preferred for easier positioning of the motorhome and a towed vehicle. If only back-in sites are available, disconnect a towed vehicle before entering the campground for easier maneuverability.

Arrive during daylight hours. If arriving late, consider parking in an open area until the following day to avoid negotiating narrow and winding campground roadways during hours of darkness. When driving through the campground, stay aware of low hanging limbs, tree trunks and barriers lining the roadway. Have the co-pilot or campground host provide exterior guidance when negotiating curves and bends. Prior to moving the motorhome into the site space, perform an exterior inspection to gauge positioning for slide rooms and awnings that is free of obstruction.

Take time to properly set up. Before lowering the air suspension and leveling the motorhome, check under the vehicle for obstacles that may damage undercarriage components. When using the automatic leveling system, prevent persons or pets from moving about the interior during the leveling process. When leveling manually, avoiding interior movement is less critical.

Monitor battery voltage. Do not allow batteries to fully discharge before engaging the generator. If possible, run the generator twice a day, morning and afternoon, to ingest a steady rate of charge to the motorhome batteries. The length of time the generator will need to run will vary on individual electrical requirements. Similar to driving a vehicle - distance dictates amount of fuel. Float indication on the inverter remote panel generally signifies a sufficient amount of charge.

### **Suggestions for Dry Camping:**

- Switch refrigerator operation from Auto to LP-Gas.
- Open windows during the day to reduce use of the roof air conditioner.
- Turn off interior 12 Volt DC power whenever possible. The refrigerator is designed to operate with the power off. Battery charging is unaffected, and the generator will continue to operate the inverter.
- Operate the optional Aqua-Hot on diesel. To conserve fuel turn the system on about twenty minutes before hot water is needed. Once heated, water will remain hot for several hours. Turn the system off when not in use.



- When interior heat is required during cold weather, set the thermostat temperature a bit lower to prevent the heating system from frequent cycling.
- Turn off small items that use battery power, such as the porch light, bay lights, the light under the step, generator compartment lights, engine compartment lights, etc. If the television is not in use, turn off the 12 Volt booster. Even one light left on, such as under the front cap, can quickly reduce battery reserves.
- Keep flashlights handy to illuminate potential barriers surrounding the campground site.
- Use a flashlight to navigate inside of the motorhome during the night to avoid running interior lights. When interior lighting is desired, use one light in a central location, such as the vanity, unscrewing all but one or two bulbs to reduce battery requirements.
- Turn on the water pump only when using water.
- If it is too early in the morning, or too late in the night, to run the generator, use the inverter for AC power, and turn off the inverter when not in use. When conditions permit, turn on the generator for a couple of hours to help charge the batteries, particularly while preparing meals.
- Frequently monitor water and battery consumption. Routinely check fuel levels, especially during cold weather temperatures.
- Plan what is needed from the refrigerator prior to opening. If weather does not permit eating at the picnic table, or no outdoor table is available, eat at the dinette table by candlelight.
- Careful management of water is critical when dry camping. Learn the motorhome tank capacities. Picture the amount of liquid in a gallon container and visualize that amount each time you use water. When dry camping for extended periods, limit shower usage. Turn water off when soaping down in the shower, and back on to rinse. When water conservation is critical, take a sponge bath. Chances are that a campground without hookups will also lack comfortable shower rooms or bathrooms, and may only be equipped with primitive facilities. However, if it helps to economize on fresh water and holding tank capacity, use them.
- Do not fill the sink full of water to wash only a few dishes. Use disposable dishes when possible.
- Conserve propane and electricity by cooking dinner over the campfire. When using the inverter to operate the microwave/convection oven, conserve battery power by engaging the generator.
- Leave shoes outdoors or at the entry step to avoid tracking in dirt.

Get back to nature and still enjoy the comforts of the motorhome. With a little imagination, the ways to conserve available resources while dry camping are endless.

**Typical Current Draw:**

- Interior house power draws 1.5 Amps just to have it on.
- A 13" TV has a 1.7 Amp draw.
- Rope lights (10 ft) are a 1.3 Amp draw.
- The porch light is a 2.0 Amp draw.
- One fluorescent dual bulb light has a 2.1 Amp draw.
- One halogen ceiling light has a .09 Amp.

## BREAKING CAMP

Below is a checklist guide to reference when preparing to break camp. Preparing the motorhome for travel will require several small tasks. Properly securing and storing items will help prevent them from getting lost or being damaged during travel.

### Outside Checklist:

- Disconnect the cable TV, lower the television antenna and (if applicable) the satellite dish.
- Disconnect and stow the phone line.
- Retract the awnings and secure them for travel.
- Close LP-Gas tank valve. Check the level of the LP-Gas Tank to ensure a sufficient amount is available.
- Drain and flush the holding tanks. First close the grey water valve, run enough cold water down the sink and shower drains until the grey tank is at least 50% full. Be careful not to overfill or flood the grey tank. Next, open the black tank valve allowing the drain cycle to complete. **If applicable**, connect a **non-potable** water hose to the No-Fuss hose bib and flush the black tank system. Close the black tank valve, open the grey water valve. The water from the grey tank will help flush the solids from the drain hose.
- Disconnect the sewer hose. Flush hose with clean water from a **non-potable** hose. Store the hose. Install the sewer cap.
- Fill the fresh water tank (using the potable hose). Disconnect and store the fresh water hose. Remove any hose protected water pressure regulator from the city water faucet.
- Turn shore power breaker off and disconnect the shore line. Wind up and store the shore cord.
- **Inspect** fluid level in oil bath hubs if applicable and check all tire pressures.
- Secure all compartment doors and entry door.
- **Inspect** tires and wheels.
- Check for fluid leaks under or around the motorhome.

### Engine Checklist:

- **Inspect** the engine, transmission and the engine compartment for fluid leaks.
- **Inspect** the area under the motorhome for fluid leaks or puddles.
- Check all fluid levels: oil, antifreeze, transmission, hydraulic fluid and washer fluid.
- **Inspect** belts and hoses for wear.
- **Inspect** wiring for loose, frayed or corroded connections.
- Start engine and listen for any unusual noises.
- **Inspect** gauges and controls for proper operation.

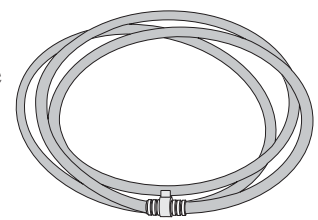
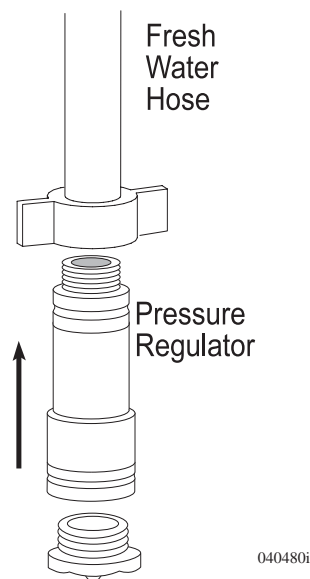

*Screw the ends of the hose together before storage to prevent leakage and to prevent dust and insects from entering the hose.*



**Interior Checklist:**

- If applicable, clear the slide room path, clean the floor, move the driver seat forward and make sure the bay doors are shut. Retract the slide room. When the slide room is fully retracted secure any slide room locks.

**NOTE: To operate the slide-out the ignition must be OFF and the park brake must be set.**

- Secure and fasten the bi-fold and pocket doors. Lock the shower door.
- Close roof vents and windows.
- Secure any loose, heavy or sharp objects in case of a sudden stop.
- Close all cabinet doors and drawers.
- Turn off interior lights.
- Turn off water heater, water pump and furnace.
- Walk through the interior and check for any unsecured items.
- Turn the interior lighting off.
- Check the fuel level gauge. Check all other dash gauges for operation and correct level indications.

**Departure Checklist:**

- Check items in storage bays to make sure shifting or damage of items will not occur.
- Look around, above and under the motorhome for obstructions. Check for debris stuck between the rear dual tires.
- Walk around the motorhome and camp area checking for forgotten items.
- Outside compartment doors should be closed and locked.
- Check operation of all exterior lights, headlamp, taillamp, brake and clearance lights.
- Secure all awning travel locks.
- When using the hydraulic jacks ensure the jack pad is clear of debris when retracted. Loose rocks, gravel and debris can be thrown from the jack pad and can possibly damage the tow car.
- Secure and lock the entry door for travel.
- Carefully pull forward out of the campsite. If necessary, clean the site and check for any forgotten items.

## EMERGENCY PROCEDURES - ROADSIDE

If an emergency situation occurs, use the appropriate braking technique and pull off the roadway a safe distance from traffic (if possible). Set the parking brake and turn on the hazard warning flashers, especially when parked alongside traffic lanes. In the event of an emergency stop due to a mechanical breakdown or other motorhome related problems, contact the manufacturer's **Customer Support** at (1-877-466-6226) or an emergency service provider.

An emergency road kit should include at least three reflective warning signs, road flares, a flashlight, spare automotive fuses and an assortment of hand tools. For added safety a separate fire extinguisher should be considered. The motorhome is equipped with a fire extinguisher located inside next to the co-pilot seat. Road flares or reflective warning signs should be displayed if the motorhome is alongside of the road for any length of time.

Guidelines for placing the warning triangles depend upon the road characteristics and visibility. For example: The standard placement is 10 feet, 100 feet and 200 feet from the rear of the motorhome when on a divided highway or one-way road. On a two-way road, with traffic traveling both directions, the same placement would also be required at the front of the motorhome. Roads with curves and hills may require the placement of the last/furthest triangle to be 500 feet behind the motorhome in order to safely warn approaching traffic.

### Jump Starting

**Alternative Starting Procedure:** A weak or discharged battery will not supply the amount of CCA (Cold Cranking Amps) necessary to initiate and maintain cranking the engine while supplying the required voltage to start the engine. If the engine fails to crank, or cranks slowly due to a weak chassis battery, there are electrical back-up systems in place that will increase chassis battery voltage.

**Battery Boost Switch:** The Battery Boost switch engages a heavy-duty solenoid to electrically connect the house batteries to the engine battery in the event the engine won't crank or cranks slowly. The solenoid is designed for short-term high current intermittent use. Engaging the boost solenoid for an extended period will damage the solenoid.

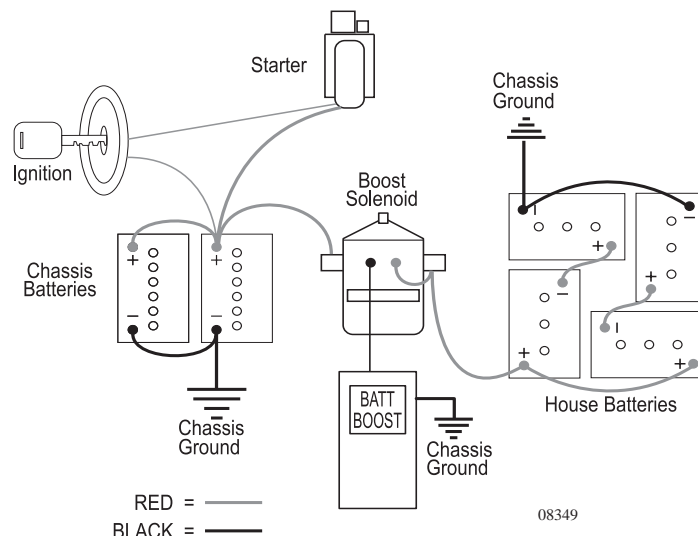

**To Use the Solenoid:**

- With the ignition key off, press and hold the Battery Boost switch for 10 seconds. After 10 seconds, continue to hold the switch down and turn on the ignition. Observe the battery volt gauge on the dash, it should read at least 12 Volts. If voltage is sufficient, try to start the engine.
- If the engine fails to crank, or does not crank fast enough, discontinue the attempt. Continued attempts will only diminish any remaining surface charge in the chassis battery ending any future alternative attempts.
- Next, start the generator. This may require using the Battery Boost switch as the generator starts from the engine battery. When the generator is operating, the electrical combination of the generator and the inverter will charge the house batteries.
- Allow the generator to run approximately ½ hour before attempting to start the engine.
- After ½ hour of generator operation, with the generator operating, hold down the Battery Boost switch for one minute. Release the switch for one minute, then engage the switch for one minute. Alternate this cycle 3 to 5 times. This will avoid overheating the Boost solenoid.
- Next, hold the switch down for one minute and turn the ignition on. The battery voltage gauge on the dash should indicate at least 12 Volts. If voltage is sufficient with the Boost switch held down, try to start the engine.
- If the engine fails to crank, or fails to crank quickly, the chassis battery may be depleted and the motorhome will require jump-starting or an external charger hooked to the chassis battery. When using jumper cables to start the engine, the cables must connect in a parallel configuration. That is positive (+) to positive (+) and negative battery (-) to negative chassis (-). Always connect the positive (+) before connecting the negative (-). To prevent arcing when disconnecting the cables, disconnect the negative (-) before disconnecting the positive (+).

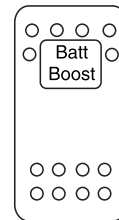

080366b

**WARNING: Batteries can emit explosive gases. Always ventilate the battery compartment prior to any work or service to the batteries. Extinguish all smoking material and keep all open flame and spark producing devices away from battery area.**

**CAUTION: A large amount of electrical current is required to jump-start an engine. The sizes of the battery, alternator and jumper cables supplying the "jump" are current limiting factors. Voltage fluctuations that occur during a jump-start procedure can damage sensitive electronic equipment and charging systems. Wait a sufficient amount of time for a surface charge to build before attempting to crank an engine when using a jump-start procedure. If uncertain about performing a jump-start procedure, contact a professional. Damage and personal injury can occur if this procedure is not performed correctly.**

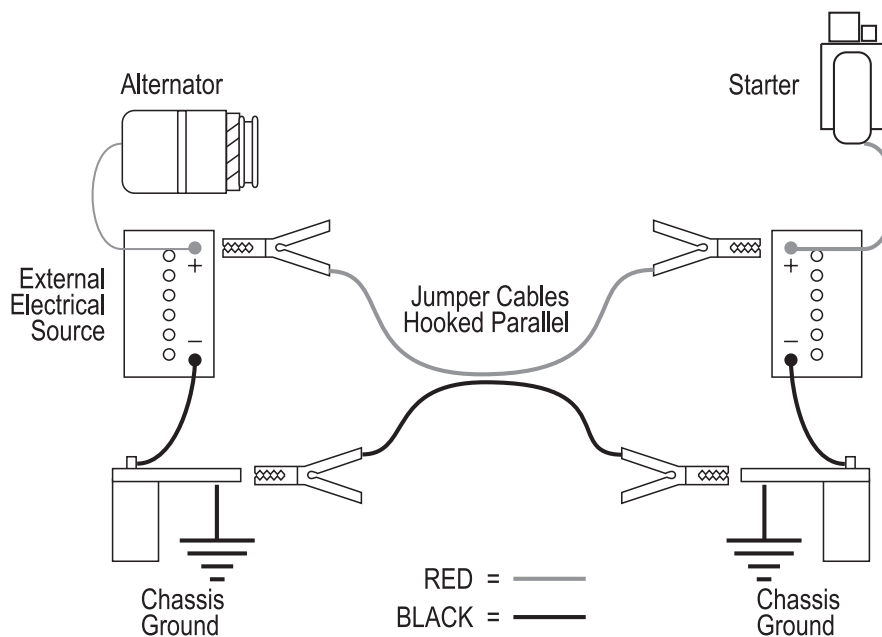

**Jump Starting:**

080350

- When using an external electrical source to connect to the chassis battery, turn the main battery disconnect switches **OFF** prior to hooking up the jumper cables.
- Hook up the cables then wait several minutes to allow a surface charge to build in the chassis battery before attempting to start the engine.
- Turn **ON** the battery disconnect switches and attempt to start the engine. **DO NOT crank the engine more than a few seconds.**
- After the engine has started disconnect the cables. Disconnect the negative (-) cables before disconnecting the positive (+) cables to prevent arcing.
- If the engine does not crank, or cranks slowly, **DO NOT CONTINUE.** Obtain assistance from a qualified technician. Extensive damage, fire or injury can occur.

In the event of a roadside emergency, contact the nearest **Cummins Center at 1-800-DIESELS (800-343-7357)** for Cummins Customer Assistance Center.

**WARNING:** The gases around the battery can explode if exposed to flames, sparks or lit cigarettes. An explosion can result in injury or vehicle damage. Batteries contain sulfuric acid, which burns skin, eyes and clothing. Do not connect the end of the second cable to the negative (-) terminal of the battery to be jumped. A spark may cause an explosion of the gases that surround the battery. Connect only to the chassis, away from the battery.

**CAUTION:** The charging system on a towed vehicle does not supply the amperage necessary to jump-start the motorhome. Voltage sensitive equipment on the towed vehicle can be damaged, leaving the towed vehicle disabled. If a jump-start is necessary, it is recommended to call Roadside Assistance. They will have the equipment necessary to jump-start the motorhome.

## TOWING PROCEDURES

If calling a towing company for service, it is recommended to use a lowboy/ landall type of trailer. If a tow truck is used it needs to have a support arm that goes under the motorhome and secures to the front axle. Inform the tow company of the axle weights and total weight of the motorhome. Other important information is the length of the motorhome, number of passengers and milepost location. Two tow trucks may be necessary. One to tow the motorhome and the other to tow a trailer or the tow vehicle if it is not operational.

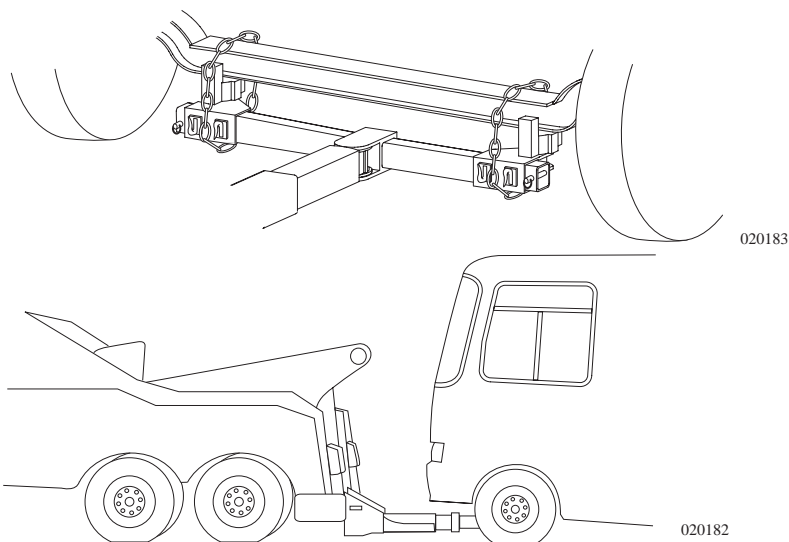

The towing company may need to locate the air nipple to release the air brakes (air brakes only). The air nipple is located in the front generator compartment and should be used by towing personnel only.

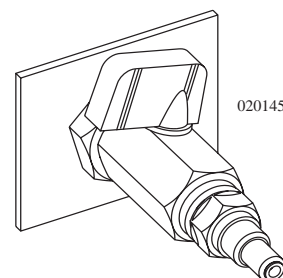

### Use the following instructions for towing the motorhome:

- Secure any loose or protruding parts if the motorhome is damaged.
- Inspect the points of attachment on a disabled motorhome. If attachment points are damaged, select other attachment points at a substantial frame structural member.
- Never allow anyone to go under a motorhome while it is being lifted by towing equipment unless the disabled motorhome is adequately supported by safety stands.
- Do not tow the motorhome from the rear. Towing from the rear will severely overload the front tires and suspension possibly resulting in tire and/or front suspension failure. Rear frame extensions are not designed to support weight loads imposed by lifting the motorhome from the rear.
- If the rear wheels are disabled, place the motorhome on a flat bed trailer or use a heavy duty dolly under the rear wheels and tow the motorhome from the front.
- The drive shaft must be removed to prevent damage to the transmission. Secure the end caps to prevent losing or contaminating the needle bearings.
- The mud flap may need to be removed to prevent damage due to limited ground clearance.

**WARNING:** In case the motorhome requires towing, ensure all precautions are followed. The drive shaft must be disconnected and the mud flap may need to be removed. The manufacturer WILL NOT cover damage to the motorhome caused by a towing company.

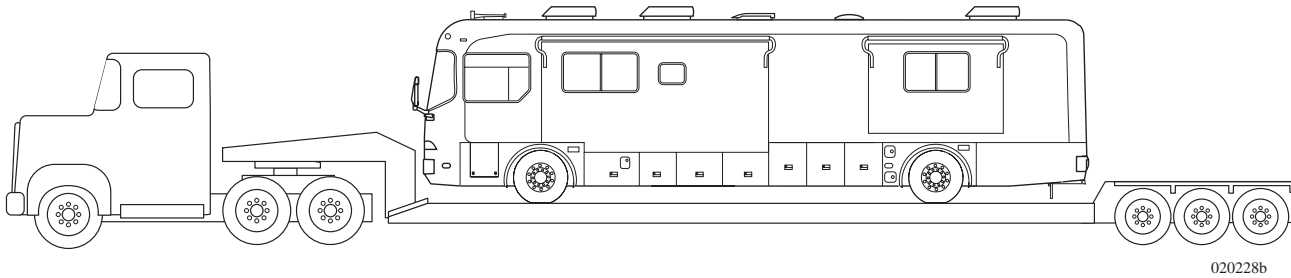

### Disabling the Parking Brake

Chock the wheels securely prior to disabling (caging) the park brake. This procedure is for emergency conditions only. Exhaust all other means of releasing the brakes prior to performing this procedure.

#### Drum Brake Models:

- Place wheel chocks firmly against the wheel before performing this procedure.
- Remove the plug from the center of rear brake chamber on the drive axle.
- Remove the caging tool from its holder on the brake chamber and insert the tool into hole. Turn the tool clockwise to engage.
- Screw nut and washer onto caging tool. Use a wrench to tighten the nut compressing the internal spring releasing the brake.
- Repeat procedure for the other side.
- After towing, or when air pressure is again available, loosen the nut and remove the tool. Return the caging tool to its original location and replace the plug.
- Repeat for the other side.

**WARNING:** Failure to securely chock the wheels can result in the motorhome rolling when the spring brakes are released. Severe injury or death can occur.

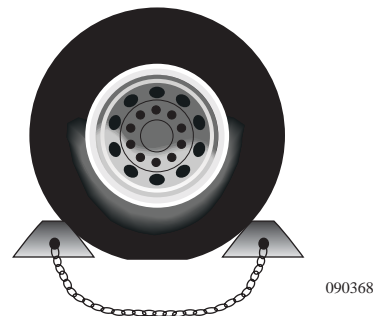

Insert Caging Tool here. Twist 1/4 turn clockwise. Install nut and washer. Tighten to release spring brake.

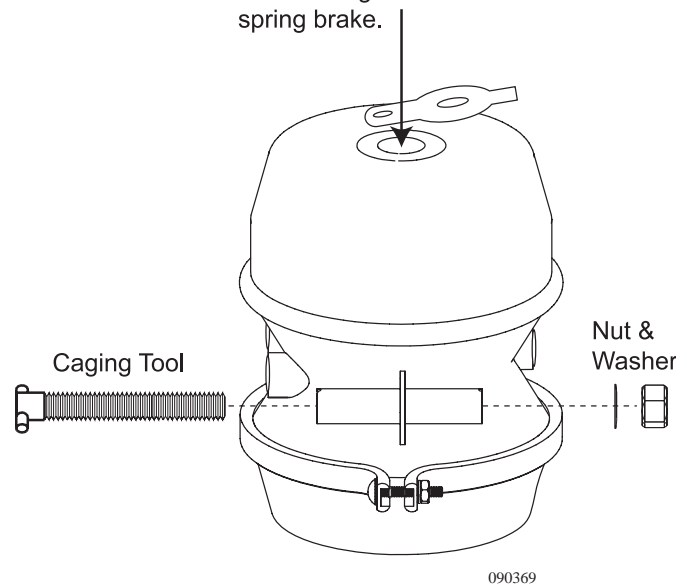

A tire designed for a motorhome is a very technical and precisely engineered product. To obtain maximum wear and the best service out of the tires, it is helpful to understand their function. A tire is a "container" that holds air. A combination of air and the tire casing support the motorhome and its contents.

The following information concerning tires, weighing the motorhome and subsequent tire information are set in the order in which the process is performed or experienced. The motorhome must be weighed fully loaded before the proper tire inflation pressure can be obtained. Since the tire is the only contact the motorhome has with the road surface, it is critical that proper tire pressure be maintained so that it will properly support the weight of the motorhome. Improper tire pressure will lead to abnormal wear or sudden tire failure.

The tire performs other functions, such as traction for moving, stopping, steering and providing a cushion for the motorhome.

Modern tire technology blends a unique mix of chemistry, physics and engineering to provide a high degree of comfort, performance, efficiency, reliability and safety. To obtain the maximum wear and best service of the tires it is helpful to understand the components and function of the tires.

#### **Tire Components:**

**Tread:** Provides traction and cornering grip.

**Belts:** Stabilize and strengthen the tread.

**Sidewall:** Protects the side of the tire from road and curb damage.

**Body Ply:** Gives the tire strength and flexibility.

**Bead:** Assures an air-tight fit with the wheel.

**Inner Liner:** Keeps air inside the tire.

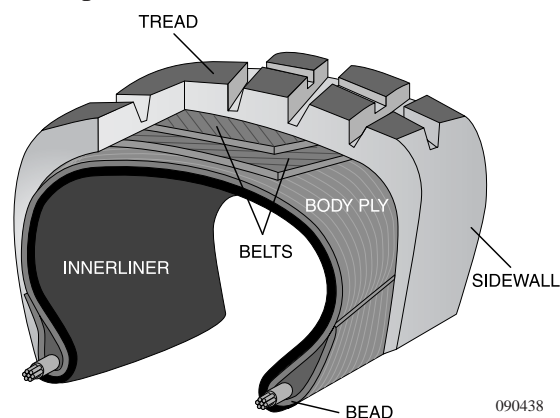

#### **Importance of Air Pressure**

The most important factor in maximizing the life of the tires is maintaining proper inflation. Driving on any tire that does not have the correct inflation pressure for the load of the motorhome is dangerous and may cause premature wear, tire damage and/or loss of control of the motorhome.

An under-inflated tire will build up excessive heat that may go beyond the design limits of the rubber and radial cords, which could result in sudden failure. An under-inflated tire will also cause poor motorhome handling, rapid and/or irregular tire wear and an increase in rolling resistance that results in a decreased fuel economy.

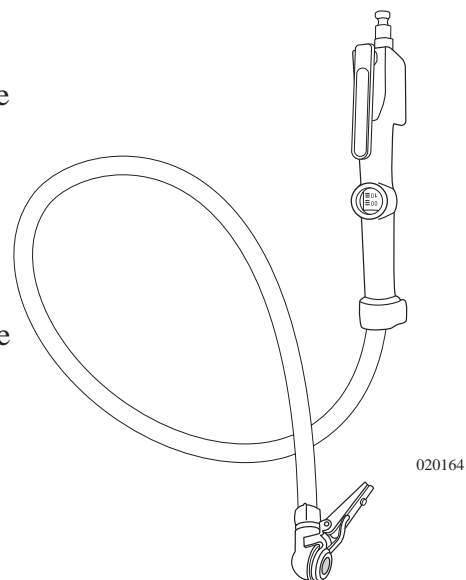



An over-inflated tire will reduce the tire's footprint/contact patch with the road, thus reducing traction, braking capacity and handling of the motorhome. Over-inflation of a tire for the load will result in a harsh ride, uneven tire wear and is susceptible to impact damage.

Maintaining correct tire inflation pressure for each loaded wheel position on the motorhome is of the utmost importance and must be a part of regular motorhome maintenance.

**WARNING: Driving on a tire that is under-inflated can exceed the design limits of the tire and may damage the sidewall. A damaged sidewall can burst upon inflation resulting in serious damage, injury or death. Aged tires are also susceptible to sidewall damage. For safety purposes clear the area of people and pets during tire inflation. Inflate the tires using a remote inflation device.**

---

### ***Tire Pressure Inflation Guideline***

Federal law requires that the specifications for the tire's maximum load rating be molded into the sidewall of the tire. The amount of air pressure to use is dependent on the weight of the motorhome when it is fully loaded. The chart within this section indicates the weights that can be properly supported by varying air pressures. Decreasing air pressure decreases load carrying capacity.

Always comply with the tire manufacturer's recommended pressure inflation guideline. The actual weight of the motorhome can vary significantly depending on how it is loaded. For optimum tire wear, ride and handling always comply with the manufacturer guideline. A tire inflation chart listing proper inflation pressure for different loads is contained in this section of the manual.

The tires of the motorhome are inflated to pressure(s) appropriate for the actual weight on each axle in the unloaded, shipped condition. When the motorhome is loaded, check and adjust the inflation pressure on each tire as needed.

Always inflate tires to the pressure indicated in the tire chart for the load carried by the tire. **DO NOT OVERINFLATE OR UNDERINFLATE THE TIRES.**

The Gross Axle Weight Rating (GAWR) of the axles listed on the federal certification label attached to the motorhome is the maximum allowable loaded weight on an axle.

When the actual loaded weight of the motorhome and the weight on each axle is unknown, follow the recommended tire inflation pressure(s) listed on the federal certification label. When loading a motorhome never exceed the motorhome's Gross Vehicle Weight Rating (GVWR) or the GAWR for each axle.

Contact the tire manufacturer for further information concerning proper tire pressure inflation and other tire issues.



Regularly check tire pressure. A nail or screw can lodge in the tire and create a slow leak. The object may eventually be spotted on a front tire or an outside rear dual. However, if there is a slow leak on an inside dual, it will probably go unnoticed. If you begin driving unaware that an inside dual tire is low on air pressure or is flat, very quickly (in most cases a few miles) the outside rear tire will heat up due to carrying double the load. This can lead to failure of the outside tire resulting in two flat tires on the same side of the same axle. Check the tire pressure every two weeks or at least once a month and before any major trip. Check the tire pressure every "drive" morning on both long and short trips (driving a day or less). Check the tire pressure before leaving on a trip and again before starting your trip home. Check the tire pressure before storing the motorhome for any length of time. More importantly, check the tire pressure when removing the motorhome from storage.

Check the tire pressure when the tires are "cold" and have not been driven for more than one mile. The rated load capacity for cold inflation pressure is based on ambient temperature. If you must check the tires when they are warm or hot, allow for a slight increase in air pressure. The pressure should be within a couple of pounds of each other on the same axle. Never let air out of a hot tire.

When checking the inflation pressure, use a high-quality truck tire air gauge. These have an angle dual head. This type of pressure gauge can check the pressure of the inner dual wheel that has the valve stem pointing outward and the outer wheel has the valve stem pointing inward. Nothing should restrict the ability to easily check tire air pressure daily when traveling in the motorhome. Use valve stem caps with a positive seal to prevent air escaping from the valve stem. If there are extension hoses on the valve stem, make sure they are good quality reinforced stainless steel braid. Attach hoses securely to the outer wheel.

Optimum tire performance is achieved at proper inflation pressure for the load carried. Do not mix tires of different tread patterns on the same axle. The difference in traction could cause rear end gear fight and mechanical damage to the drive train. Never mix tires of a different size or construction on the same axle.

#### **Higher than recommended pressure can cause:**

- Hard Ride.
- Tire Bruising or Carcass Damage.
- Rapid Tread Wear in the Center of the Tire.

**WARNING: Improperly inflated tires can effect handling or cause sudden tire failure possibly resulting in loss of vehicle control. Always use an accurate tire pressure gauge when checking tire pressure.**

#### **Lower than recommended pressure can cause:**

- Tire Squeal on Turns.
- Rapid and Uneven Wear on the Edges of Tread.
- Tire Container Bruise or Rupture.
- Tire Cord Breakage.
- Higher Risk of Road Hazard.
- Excessive Tire Temperature.
- Separations.
- Circumferential Breaks
- Loss of Casing Durability
- High Fuel Consumption
- Reduced Handling Quality.

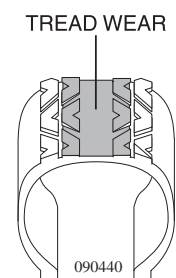

*Example of Overinflation. More wear in center*

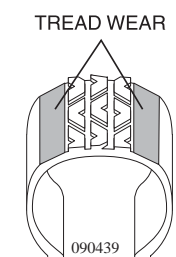

*Example of Underinflation More wear on edges.*

**WARNING:** Driving on a tire with low air pressure can exceed the design limits of the tire. Damage to the sidewall of the tire can occur. A damaged sidewall can burst upon inflation causing serious damage, injury or death. Aged tires are also susceptible to sidewall damage.

Unequal tire pressures on same axle can cause:

- Uneven Braking, Swerve Upon Acceleration.
- Steering Lead, Torque Steer.
- Reduced Handling Quality.

**WARNING:** A slow leak may go unnoticed on one of the dual tires. This can cause the other tire to fail due to exceeding the load limits it is designed to carry. Tires with damaged sidewalls can burst upon inflation. A flat or nearly flat tire can also generate enough heat from friction to ignite.

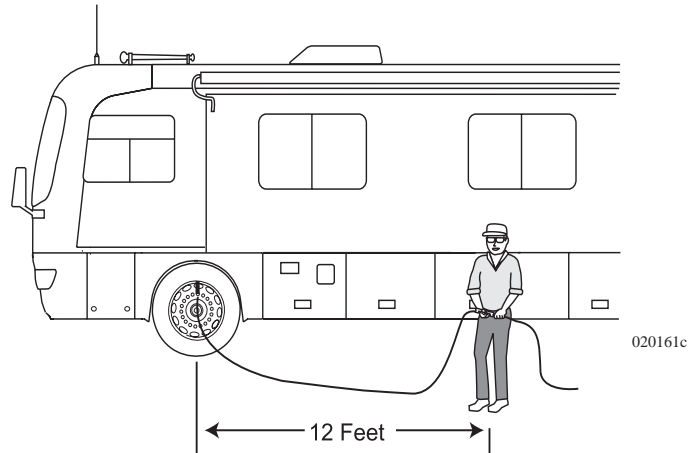

### **Air Pressure Checklist**

1. When checking air pressure, make sure the tires are cool - meaning they are not hot from driving, even a mile.

**NOTE:** If the motorhome must be driven a distance to get air, check and record tire pressure first. Add appropriate air pressure when reaching the pump. It is normal for tires to heat up and the air pressure inside to go up as driven. Never “bleed” or reduce air pressure when tires are hot.

2. Remove cap from the valve.
3. Firmly press a tire gauge onto the valve and record reading.
4. Add air to achieve recommended air pressure.
5. If the tire is over filled, release air by pushing on the metal stem in the center of the valve. Recheck the pressure with the tire gauge.
6. Replace the valve cap.
7. Repeat with each tire.
8. Visually inspect the tires to ensure there are no nails, or other objects, embedded that could poke a hole in the tire and cause an air leak.
9. Check the sidewalls to make sure there are no gouges, cuts, bulges, or other irregularities.

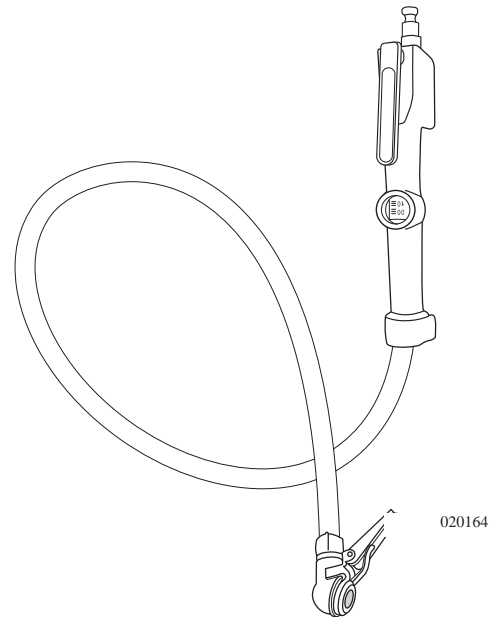

**NOTE:** Air pressure in a tire goes up (in warm weather) or down (in cold weather) 1-2 pounds for every 10 degrees of temperature change.

**Supporting When Leveling**

Extreme caution must be taken to ensure that the tires are fully supported when placing blocks under the tires. The load on the tire should be evenly distributed on the support block. In the case of dual tires, distribute the load evenly on blocks for both tires. If not properly supported, the steel cables in the sidewall of the tires may be damaged and could lead to premature fatigue of the sidewall.

**CAUTION:** Supporting the tires prevents damage to the sidewall of the tires and does not prevent tire roll.

## Tire "Support" Methods

### INCORRECT

#### Singles

Only a portion of the tire is supporting the full load.

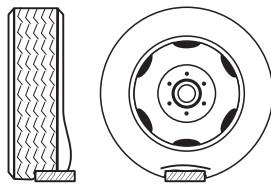

#### Duals

One tire or a portion of one tire is supporting the full load.

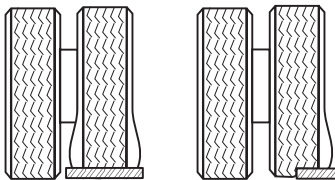

One tire or a portion of the two tires supporting the full load.

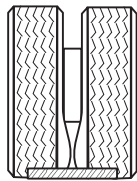

### CORRECT

#### Singles

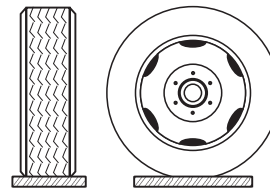

#### Tire Footprints



#### Duals

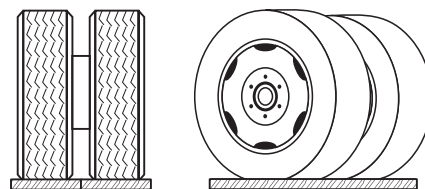

#### Dual Tire Footprints

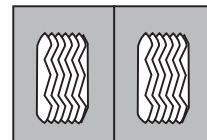

020063b modified

## **Tire Vibration**

Sudden tire failure or blowout is often preceded by tire vibration. Some other symptoms that can cause tire failure are a bulge in the sidewall or swelling in the tire carcass. Striking an object or large hole in the road surface can damage a tire. Inspect the tires immediately after such an occurrence. Continue to inspect the tires periodically thereafter in case minor damage occurred. Rotation forces can continue to stress damaged areas that can manifest later in a sudden tire failure. If an unusual vibration begins, or a bulge is noticed in a sidewall, have the tires evaluated by a qualified professional as soon as possible.

---

## **Tire Rotation**

Tire rotation can increase the useful life of the tires by achieving uniform wear on all of the tires. The first tire rotation is the most important in determining which rotation pattern to use. Have the tire manufacturer determine the tire rotation pattern. Any unusual or unique wear patterns, or indications of uneven wear that may have developed, should be evaluated for possible tire rotation. Misalignment, imbalance or other mechanical problems may exist and will need corrected prior to rotation.

After a tire rotation, check and adjust the inflation pressures for the actual loads of the wheel position accordingly.

Tires are warranted by the tire manufacturer. The motorhome manufacturer is not responsible for warranty coverage or tire wear.

---

## **Tread**

Tires must be replaced when the tread is worn down to  $\frac{4}{32}$  of an inch on the front and  $\frac{2}{32}$  of an inch on the rear in order to prevent skidding and hydroplaning. If there are questions regarding tread wear consult the tire manufacturer as soon as possible.

Built in tread wear indicators, or “wear bars,” which look like narrow strips of smooth rubber across the tread will appear on the tire when the tread is worn down to one-sixteenth of an inch. When these “wear bars” are noticed, the tire is worn out and should be replaced.

Visually check the tires for signs of uneven wear. The tire may have irregular tread wear if there are high and low areas or unusually smooth areas. Consult the tire manufacturer as soon as possible.

**WARNING: In many instances the life of the tires on the motorhome is not determined by mileage but by age. Tires are subject to weathering. Weathering cracks run in circumference with the tire. Though the sidewall of the tire may look fine and be structurally sound, weathering can occur inside the well of the tread. Replacement may be determined not by mileage, but by age. Have the tire manufacturer inspect tires for age weathering.**

In the event of a flat tire, it is recommended to call for roadside assistance. The size and weight of the motorhome and its tires require the proper equipment to change the tire. A professional service technician will have the equipment and training needed to repair or replace a tire. In the case of sudden tire failure, avoid heavy braking. Hold the steering wheel firmly and gradually decrease speed. Slowly move to a level, firm, safe, off-road place. Turn the ignition off and turn the hazard flasher system ON. Save the old tire for any possible warranty coverage.

### Hub Piloted Mounting:

- Before using flange nuts that have already been used in service, apply two drops of oil at one point between the flange and hex, allowing parts to rotate freely and provide the proper clamping force when tightened. Use any lubricant typically used for fasteners. Examples are motor oil and general purpose lubricating oils. Excessive lubricant is not ideal and will not improve the nut torquing performance. Excessive lubricant makes the nuts hard to handle, attracts dirt to the nuts and may cause unsightly appearance to the wheel. Only used nuts need to be lubricated.
- Flange nuts generate higher clamping force always use grade eight studs with hub mount wheels.
- Before installing the wheels, lubricate hub pilot pads with a drop of oil to prevent galling. Do not lubricate other wheel or other-hub surfaces.
- For a hub with intermittent pilot pads, position a pad at the 12 o'clock position to center the wheel and reduce runout.

For Used Nuts  
Add 2 drops of Oil  
Between Flange  
and Hex

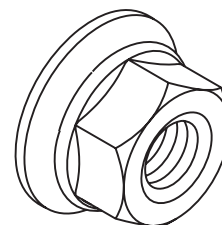
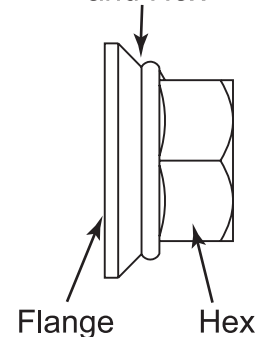

090268c

Flange Nut: Front and side view.

**NOTE:** Loosen and tighten lug nuts in a star pattern sequence. Sequence tighten to 50 ft. lbs. first, then sequence tighten to 500 lbs. Over-tightening can cause distortion.

**WARNING:** Never use wheels or lug nuts different than the original equipment as this could damage the wheel or the mounting system. Damage to the wheel or mounting system could cause a wheel to come off while the recreational vehicle is in motion.

**Front Wheels:** Slide the front wheel over the studs. Avoid damaging stud threads. Snug the nuts in sequence. When all nuts have been seated, tighten to 500 ft.lbs in sequence (see illustration).

**Dual Rear Wheels:** Slide the inner dual wheel over the studs. Avoid damaging threads. Align the handholds for valve access and slide the outer dual wheel over the studs; avoid damaging the stud threads. When all nuts are seated, tighten the nuts to 500 ft. lbs. in sequence (see illustration).

The hub mount wheels use two-piece flange cap nuts for both front and rear applications. No inner cap nuts are required.

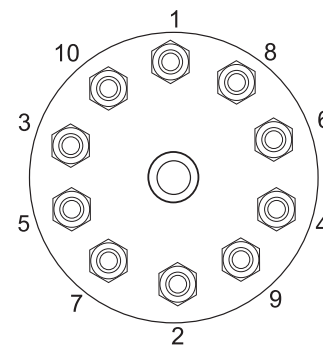

Nut Tightening Sequence

090268 copy 2

**Torque the Nuts Properly:**

- Tighten the wheel nuts to the recommended lug nut torque. Do not over tighten
- Maintain the nut torque at the recommended level through planned periodic checks or at 10,000 miles intervals, whichever comes first.
- If air wrenches are used they must be periodically calibrated for the proper torque output. Use a torque wrench to check the air wrench output and adjust the line pressure for the correct torque.

---

**Storage of Tires - Long Term**

Rubber tires age faster when not being used. A cool, dry, sealed garage is the preferred method of storage. Many recreational vehicles are stored outside in the elements. Some storage surfaces may cause tires to age prematurely. Placing a barrier (i.e. cardboard, plastic or plywood) between the tire and the storage floor/ground surface will help to protect the tires.

When the tire is anticipated to be out of service for a period of thirty days or more, the motorhome should be in the long-term storage condition.

**NOTE: If the motorhome is stored with weight on the tires they should be inflated to the maximum inflation pressure as indicated on the Federal Identification Tag.**

- Thoroughly clean the tires.
- Unload the motorhome so there is minimum weight on the tires.
- Ensure the surface is reasonably level, firm, clean and has good drainage.
- Move the motorhome every three months to prevent cracking in bulge areas as well as flat spotting from prolonged sidewall strain and tread deflection.
- Cover the tires to block direct sunlight and ultraviolet rays.

The type of surface the motorhome is parked upon will have an affect on much moisture accumulation occurs on the chassis and flooring.

- Gravel covered parking area still allows moisture to evaporate from the ground, through the gravel and to the underside of the motorhome.
- Sealed concrete pads allow better ventilation under the motorhome.
- Storage buildings with sealed concrete floors or heated storage facilities greatly reduce the amount of moisture accumulation and protect the motorhome from moisture damage.
- Wet, oily, or greasy surfaces should be avoided. Highly reflective surfaces such as black asphalt, sand or snow, should be avoided.

Before removing the motorhome from long-term storage thoroughly **inspect** each of the tires. This means a close examination of each tire's tread area and air pressure. If the pressure check indicates the tires have lost air during storage, inflate them to the correct pressure for the current load before putting the motorhome into service.



---

## WEIGHING THE MOTORHOME

Proper weight distribution, load management and operating within established limitations will aide in safe and enjoyable travel. The information contained in this publication outlines guidelines and provides worksheets for weighing procedures.

Proper weight distribution and load management is an individual responsibility. Once the process and procedures are understood, weighing the motorhome really isn't complicated. In order to correctly manage load and weight distribution, more than one weight measurement will need to be taken and/or repeated. Each wheel position must be weighed to accurately determine the weight placed on each wheel position for proper weight computations.

The entire process of weigh management begins with the Gross Vehicle Weight Rating as listed on the Federal Certification Label. **This weight cannot be exceeded.**

**CAUTION: Most States limit the amount of weight carried by any single axle position. It is the responsibility of the operator to know the legal weight limit of the State in which they travel.**

---

### *Weight Terms*

Numerous Federal, State and local governments mandate weight limits. Understanding the terminology and performing proper weighing procedure will help eliminate confusion. It is important to understand there are two reasons to weigh the motorhome. One to find out the **Cargo Carrying Capacity (CCC)** and the other to ensure no axle is overloaded.

The **Gross Axle Weight Rating (GAWR)** of the axles is listed on the federal certification label attached to the motorhome. This is the maximum allowable loaded weight on a particular axle. This label is generally located to the rear of the driver's seat, on the wall. When the actual loaded weight of the motorhome, and the weight on each axle is unknown, follow the recommended tire inflation pressure(s) listed on the federal certification label. When loading a motorhome never exceed the motorhome **Gross Vehicle Weight Rating (GVWR)** or the **GAWR** for each axle.

**NOTE: Contact the tire manufacturer for further information concerning proper tire pressure inflation and other tire issues.**

The **Gross Vehicle Weight Rating (GVWR)** and **Gross Axle Weight Rating (GAWR)** listed on the Federal Certification Label attached to the motorhome will detail the chassis manufacturer's and/or the RV manufacturer's total vehicle maximum weight rating and per axle weight rating.

The **GVWR** is the maximum total weight for which the motorhome is rated - including passengers, fluids and cargo. The **GAWR** is the maximum weight for which a single axle is designed. The tires, wheels, axle, the motorhome frame and/or other components of the motorhome, could limit these per axle and total maximum weight ratings.

The Federal Certification Label is a guide in knowing the maximum loaded axle weight rating **GAWR**, and subsequently the correct tire inflation pressure for that weight. Every recreational vehicle, even of the same make and model, will vary in actual loaded axle weights because of different options and personal loads.

While the actual loaded axle weight should be below the **GAWR**, the motorhome must be weighed in a loaded condition to know its actual weight. Weigh the front axle, the total unit and the rear axle. It is possible for a motorhome to be within the **GVWR** yet overloaded on an axle. It is even possible for one wheel position to be overloaded, even though the **GAWR** has not been exceeded. For this reason it will be necessary to weigh each wheel position of the motorhome to give a clear indication of exactly how the weight of the motorhome is distributed.

Instructions and diagrams are presented on the following pages. When the total weight and the weight on each axle is known, the tire load data chart in this manual will show the correct cold inflation pressure per tire for each axle.

There are two important factors to consider when loading the motorhome: **total weight** and **balance**. When loading heavy objects keep them as low as possible, preferably on the floor or below in storage compartments. Load weight must be distributed as evenly as possible.

- **Gross Vehicle Weight Rating (GVWR):** Maximum permissible weight of this motorhome. GVWR is equal to or greater than the sum of UVW plus CCC.
- **Unloaded Vehicle Weight (UVW):** Weight of this motorhome as built at factory with full fuel, engine oil and coolants. UVW does not include cargo, fresh water, LP-Gas, occupants or dealer installed accessories.
- **Cargo Carrying Capacity (CCC):** Equal to GVWR minus each of the following: UVW, full fresh potable water weight (including water heater), full LP-Gas weight, and SCWR. Tongue weight of towed vehicle and dealer installed equipment will reduce CCC.
- **Gross Combination Weight Rating (GCWR):** The maximum allowable combined weight of this motorhome and the towable product.
- **Gross Axle Weight Rating (GAWR):** Load-carrying capacity specified by manufacturer of a single axle system, as measured at tire ground interfaces.
- **Sleeping Capacity Weight Rating (SCWR):** The manufacturer's designated number of sleeping positions multiplied by 154 pounds.

**Tire Pressure:** A motorhome may weigh slightly heavier on one side than on the other. Tire inflation pressure of the heavier side tires determine the inflation pressure for all tire(s) on that axle due to the weight transfer that occurs when cornering. The weight load will be transferred on the opposite side from the direction in which the motorhome is cornering.

Improperly inflated tires, or suspension that is incorrectly loaded, can result in poor fuel economy, poor handling and over-stressed chassis components. Vehicle loading will influence tire inflation pressure and the load carried by each axle. This is why each wheel position must be weighed. Motorhome axle configuration and floor plan styles will require different weighing procedures.

**NOTE:** When weighing a motorhome, each tire on any axle must be inflated to the same pressure. The wheel position carrying the most weight will determine the tire inflation pressure for each tire of that particular axle.



**Scales:** Certified public scales are located in a variety of places such as moving and storage lots, farm suppliers with grain elevators, gravel pits, recycling companies and large commercial truck stops.

If you are not aware of a nearby public scale, check the local area telephone book yellow pages under "scales-public" section or "weighers." A nominal fee will be charged, but this is money wisely spent.

Weight scale types and weighing methods determine the procedure used to calculate proper tire inflation pressure and axle loading. Several types of scales are in use today. A platform scale will allow the entire motorhome to fit on the scale to read the GVW in one scale recording. A segmented platform scale is designed to weight one axle at a time. A single axle scale weighs one axle at a time. Some scales read only one wheel position at a time due to physical size. Several scale readings may be required to determine the GAW or GVW total. Each wheel position requires weighing, referred to as a six-point weigh, to accurately determine the correct tire inflation pressure.

**NOTE: The most accurate method to determine proper tire pressure is a four-corner or four point weigh. Each wheel position must be weighed independently. Weighing the entire axle will not accurately determine the total weight carried by that wheel position. When calculating the drive axle dual tire pressure using a independent corner weigh method, divide the total weight by two to determine the weight carried by each tire. Each wheel position must be weighed and recorded.**

During weighing, the scales as well as the motorhome must be as level as possible to obtain an accurate scale reading. Even though an axle or side is not physically on the scale, a definite lean in the motorhome will produce inaccurate scale readings.

**Weight Label**

<b>MODEL YEAR:</b> _____	<b>MAKE:</b> _____	<b>MODEL:</b> _____
<b>UNIT NO.</b> _____	<b>CHASSIS VIN:</b> _____	
	<u>LBS.</u>	<u>KGS.</u>
<b>GVWR</b>	(Gross Vehicle Weight Rating) is the maximum permissible weight of this fully loaded motorhome .....	
	_____	_____
<b>UVW</b>	(Unloaded Vehicle Weight) is the weight of this motorhome as manufactured at the factory with full fuel, engine oil and coolants.....	
	_____	_____
<b>SCWR</b>	(Sleeping Capacity Weight Rating) is the manufacturer's designated number of sleeping positions multiplied by 154 pounds (70 kilograms) .....	
	_____	_____
<b>CCC</b>	(Cargo Carrying Capacity) is the GVWR minus each of the following: UVW, full fresh (potable) water weight (including water heater), full LP-Gas weight and SCWR (*1).....	
	_____	_____
<b>GCWR</b>	(Gross Combination Weight Rating) is the maximum allowable combined weight of this motorhome and the towable product. (*1).....	
	_____	_____
	FACTORY INSTALLED OPTIONS are options installed at the factory but do not include dealer installed after market equipment...	
	_____	_____
<b>CARGO CARRYING CAPACITY (CCC) COMPUTATION</b>		
GVWR .....	_____	_____
minus UVW .....	_____	_____
minus fresh water (*2) weight of ___ gallons @ 8.3 lbs./gal .....	_____	_____
minus LP-Gas weight of ___ gallons @ 4.2 lbs./gal .....	_____	_____
minus SCWR of ___ persons @ 154 lbs./person.....	_____	_____
CCC for this motorhome (*3) .....	_____	_____
<b>WARNING: CONSULT OWNER MANUAL(S) FOR SPECIFIC WEIGHING INSTRUCTIONS AND TOWING GUIDELINES INCLUDING AUXILIARY BRAKE REQUIREMENTS FOR ANY TOWED TRAILER OR TOWED VEHICLE.</b>		
<b>Factory installed options do not include dealer installed after market equipment.</b>		
<b>WARNING: DO NOT EXCEED THE GVWR, GCWR AND/OR GAWR AFTER LOADING YOUR MOTORHOME WITH WATER, FUEL, PASSENGERS AND CARGO. GAWR (Gross Axle Weight Rating) means the maximum permissible load weight a specific axle is designed to carry. See Federal Certification Label for disclosure of The GAWR for each axle.</b>		
(*1) Towing capacity is limited by GCWR; your vehicle's towing capacity is the difference between the GCWR and the actual vehicle weight; including all water, fuel, passengers, and cargo. Consult your Owner's Manual for further information.		
(*2) Your motorhome's fresh water tank and water heater taken together determine the gross fresh water capacity. Your usable fresh water capacity, however, may be less.		
(*3) Dealer installed equipment and towed vehicle tongue weight will reduce CCC.		

**Four Point Weighing (Example)**

**NOTE:** Following scale readings and Gross Axle Weight Ratings are fictitious. Actual scale readings and Gross Axle Weight Ratings will vary with model and options.

The motorhome must be weighed fully loaded to obtain accurate scale readings and to determine the proper tire pressure. All slide rooms must be in retracted position.

- Take the rear axle **Gross Axle Weight Rating (GAWR)** and divide it by two. Example: Rear axle **GAWR** taken from the motorhome Vehicle Certification Label is 20,000 lbs. Divide the figure by 2, using chart below, record 10,000 lbs. on Scale B and D, line 1.
- Weigh the driver side rear corner (Scale B) and record weight on chart Scale B, line 2. Example: 5,500 lbs.
- Weigh the passenger side rear corner (Scale D) and record weight on chart Scale D, line 2. Example: 5,000 lbs.
- Add chart Scale B and D, lines 1, for **Gross Axle Weight Rating (GAWR)** and record on chart under Totals. Example: 20,000 lbs.
- Add chart Scale B and D, lines 2, for actual **Gross Axle Weight (GAW)** and record on chart under Totals. Example: 10,000 lbs.
- Actual **Gross Axle Weight (GAW)**. Example: 12,500 lbs., is not to exceed **Gross Axle Weight Rating (GAWR)**. Example: 20,000 lbs.

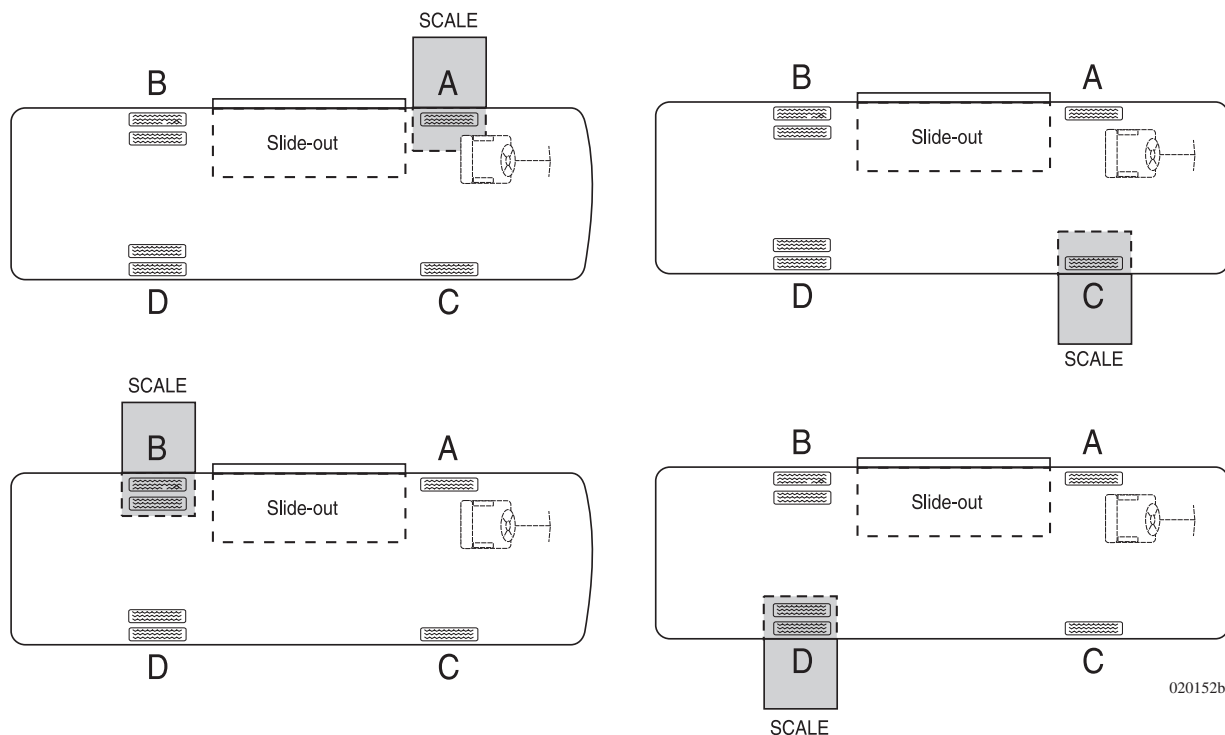

- Refer to the Tire Chart (Tire size 275/70R22.5). Use the highest actual weight, Scale B or D, line 2. Example 5,500 lbs. Determine the proper tire pressure for each tire using the Load Inflation chart. Example: 105 psi or stamp on the sidewall of the tire.
- Repeat above procedures to determine front axle Scale A and C, tire pressures.

	ROADSIDE		CURBSIDE		TOTAL AXLE WEIGHT	GROSS AXLE WEIGHT RATING GAWR	GAWR Minus Total Axle Weight
FRONT AXLE	1. 6,500	+	6,500	=	13,000	13,000	2,500
	2.(A) 5,500		(C) 5,000		10,500		
DRIVE AXLE	1. 10,000	+	10,000	=	20,000	+ 20,000	9,500
	2.(B) 5,500		(D) 5,000		+ 10,500		
			Total Axle Weight		= 21,000 UVW	= 33,000 GVWR	= 12,000 CCC

**NOTE:** These measurements are with a full tank and nobody in the motorhome.

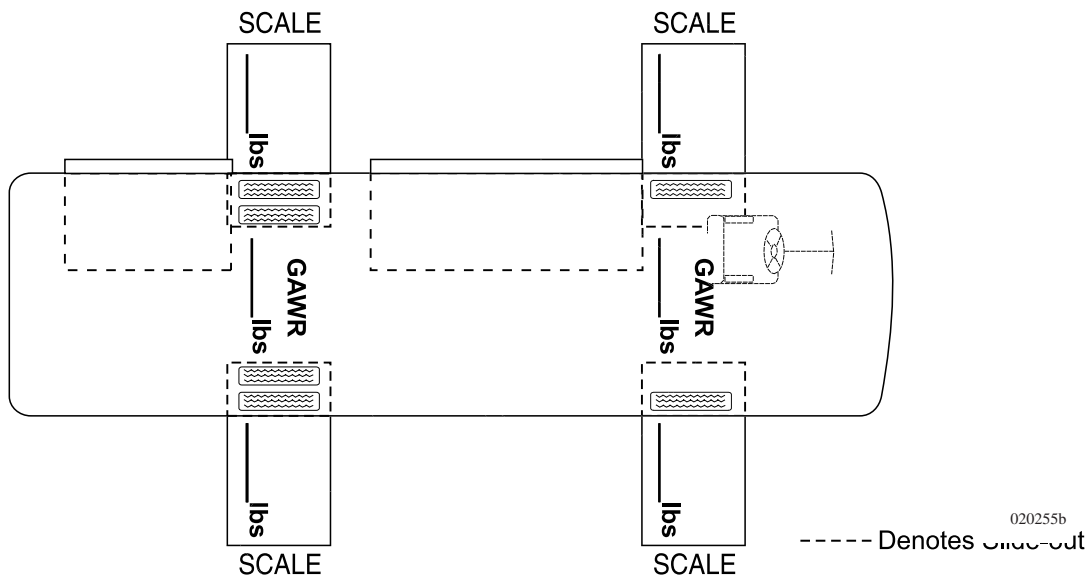

**WARNING:** Improperly inflated or overloaded tires can cause a blowout. An overloaded axle can cause a component failure of the suspension system. Tire blowout or broken suspension components can lead to loss of vehicle control resulting in property damage, personal injury or death.

**CAUTION:** If actual weight carried by any tire is below the tire chart weight specification minimum tire pressure the minimum inflation pressure must be maintained. Tire pressure below the minimum inflation pressure can overheat and damage the tire casing leading to premature tire failure or blowout.

**Load and Inflation Tables:** The load and inflation table helps to determine the correct inflation for the motorhome tire, after properly weighing the motorhome. All pressures are rated at a cold psi. Cold conditions are defined as early in the morning before the day's ambient temperature, sun's radiant heat or the heat generated while driving have caused the tire pressure to temporarily increase. This means that the pressure should be checked early and when the motorhome has not been driven more than one mile. The check interval should be in the morning, before the "drive" trip and every morning on extended trips. A quality truck tire gauge with a multiple angle airhead is needed to ensure access to both dual wheel positions of the drive axle. Ensure the valve cap is replaced on the stem after the inflation is checked. This guarantees the valve core will remain free of dirt and foreign material. Material lodged between the valve core and internal stem can cause slow leaks resulting in tire failure.

**Understanding the Inflation Table:**

- Tire Size is on the left margin of the Table.
- Determine the "Single" inflation reading or "Dual" inflation reading. This is denoted with a "D" or "S" on the Table. Single is for the Front axle. Dual is for the Drive axle.
- Find the corresponding psi at the top columns to see the corresponding maximum weight capacity for that psi.

**NOTE:** Every load range has a maximum rating as well as a minimum rating. Do not exceed those ratings.

- Rated load capacities are listed for individual tires in a Dual or Single position.

TIRE SIZE	MAX Speed Rating (MPH)	Dual (D) Single (S)	INFLATION PRESSURE PSI												
			65	70	75	80	85	90	95	100	105	110	115	120	125
8R19.5	75	D	2350	2460	2570	2680	2780	2880	2980	3070	3160	3375(F)			
		S	2410	2540	2680	2800	2930	3060	3170	3280	3400	3500(F)			
225/70R19.5	75	D		2720	2860	3000	3115	3245	3415(F)						
		S		2895	3040	3195	3315	3450	3640(F)						
245/70R19.5	75	D		3415	3515	3655	3875(F)	3940	4075	4375(G)					
		S		3640	3740	3890	4080(F)	4190	4335	4545(G)					
265/70R19.5	75	D				3750	3930	4095	4300	4405	4560	4805	4860	5070(G)	
		S				3970	4180	4355	4540	4685	4850	5070	5170	5355(G)	
9R22.5	65	D	3120	3270	3410	3550	3690	3820	3950(F)						
		S	3190	3370	3560	3730	3890	4050	4210	4350	4500(F)				
10R22.5	65	D	3690	3870	4040	4200	4375	4520	4670	4875(F)	4970	5110	5250(G)		
		S	3770	4000	4210	4410	4610	4790	4970	5150(F)	5320	5490	5680(G)		
11R22.5	75	D				4760	4950	5120	5300	5470	5750(G)	5800(H)			
		S				4990	5220	5430	5640	5840	6175(G)	6240	6430	6610(H)	
12R22.5	65	D				5190	5390	5590	5780	5960	6150	6320	6500	6750(H)	
		S				5450	5690	5920	6140	6370	6590	6790	7010	7390(H)	
245/75R22.5	75	D		3260	3425	3640	3740	3890	4080	4190	4335	4410(G)			
		S		3470	3645	3860	3980	4140	4300	4455	4610	4675(G)			
255/70R22.5	75	D		3585	3765	3970	4110	4275	4410	4455	4610	4675	5070(H)		
		S		3815	4005	4190	4370	4550	4675	4895	5065	5205	5510(H)		
265/75R22.5	75	D			4040	4205	4370	4525	4685	4800	4975	5150	5205(G)		
		S			4070	4255	4440	4620	4800	4975	5150	5205(G)			
275/70R22.5	75	D				4535	4750	4960	5165	5370	5575	5775	5975	6175(H)	
		S				4885	5080	5305	5530	5750	5965	6185	6400	6610(H)	
275/80R22.5	75	D				4855	5080	5305	5525	5745	5965	6180	6395(H)		
		S				5265	5515	5755	6000	6235	6475	6710	6940(H)		
295/75R22.5	75	D		4690	4885	5070	5260	5440	5675(G)	5800	6005(H)				
		S		4725	4945	5155	5370	5510	5780	5980	6175(G)	6370	6610(H)		
295/80R22.5	75	D			4855	5100	5335	5570	5805	6035	6265	6490	6720	6940(H)	
		S			5480	5750	6020	6285	6550	6810	7070	7320	7580	7830(H)	
315/80R22.5	75	D				5840	6070	6395	6540	6770	6940	7210	7610(J)	7390	
		S				6415	6670	6940	7190	7440	7610	7920	8270(J)	8820	
285/75R24.5	75	D		4740	4930	5205	5310	5495	5675(G)						
		S		4770	4990	5210	5420	5675	5835	6040	6175(G)				

**Cargo Carrying Capacity:** When weighing the motorhome it is important to understand that each motorhome, even of the same model year, floorplan and length will weigh different due to options and accessories. The **Gross Vehicle Weight Rating (GVWR)**, **Gross Combination Weight Rating (GCWR)** and/or **Gross Axle Weight Rating (GAWR)** must not be exceeded.

**GVWR** of the vehicle limits the weight of the entire load combination, regardless of the mix of water, LP-Gas, passengers, or cargo.

It is important to understand the weighing process is performed in two phases. The first phase is determining the **Cargo Carrying Capacity (CCC)** and the second to ensure the **GVWR** is not exceeded when adjusting tire pressures. The weighing process should start by recording the **GVWR** from the Federal Weight Label, then weighing the motorhome unloaded, without passengers and with a full fuel tank. Engine and transmission fluid levels must be full. This is known as the **Unloaded Vehicle Weight (UVW)**. Once this weight has been recorded it can be subtracted from the **GVWR**.

$$\text{GVWR } \underline{33,000} - \text{UVW } \underline{21,000} = \text{A } \underline{12,000}$$

Next, begin to calculate the **Cargo Carrying Capacity (CCC)**.

Fresh water weight and LP-Gas weight can now be subtracted from the remaining total line A.

- Water weight is the number of gallons multiplied by 8.3.
- LP-Gas weight is the number of gallons multiplied by 4.2.

A 12-gallon water heater with a 95-gallon fresh tank would total 107 gallons times 8.3, or 888 pounds.

A 55-gallon LP-Gas tank will have 44 gallons of LP-Gas due to the 80% liquid capacity. This would mean 44 gallons multiplied by 4.2, or 185 pounds.

$$\text{A } \underline{12,000} - 888 = \text{B } \underline{11,112}$$

$$\text{B } \underline{11,112} - 185 = \text{C } \underline{10,927}$$

Next, calculate the **Sleep Capacity Weight Rating (SCWR)**. The manufacturer designated number of sleeping positions for the motorhome multiplied by 154 pounds.

The 154 pounds (70kg) is the average weight established by the US Federal Government and Transport Canada, and is used to arrive at **Cargo Carrying Capacity (CCC)**. However, actual sleep capacity weight may be greater. The **SCWR** is not intended to limit the sleeping capacity to a specified weight.

**Example:** If the manufacturer has designated the motorhome sleeping position at 5 (770 pounds) and there are five people who weigh 200, 150, 150, 140 and 130 pounds, totaling 770 pounds, that doesn't mean the sleeping capacity is reduced to three individuals, but rather the **CCC** is reduced to the actual passenger

$$C \quad \underline{10,927} \quad - \text{SCWR} \quad 770 \quad = \text{CCC} \quad \underline{10,157}$$

**Cargo Carrying Capacity (CCC)** is how much cargo the motorhome can carry. However, tongue weight of a towed vehicle will further reduce this amount.

Now the motorhome can be fully loaded and weighed to ensure **GVWR** is not exceeded. When weighing the motorhome, all slide rooms must be in the retracted position. The motorhome must remain as level as possible on the scale, even though an axle or side is not physically on the scale. Once the motorhome is fully loaded and weighed to obtain an accurate scale reading, determine the proper tire pressure.

- Each wheel position must be weighed to accurately determine the weight carried at each wheel position.
- Refer to the previous examples on how to weigh each wheel position. Each wheel position weight must be weighed and recorded to determine proper tire inflation.
- Wheel position weights are not to exceed any **Gross Axle Weight Rating (GAWR)** and **Gross Vehicle Weight Rating (GVWR)** as printed on the Motorhome Vehicle Certification Label.
- Compare wheel position weights with weigh ratings on the label. Do not operate if wheel position weights exceed maximum specifications. Items will need to be removed until rating weight is within specification.

**Cargo Carrying Capacity Flowchart**

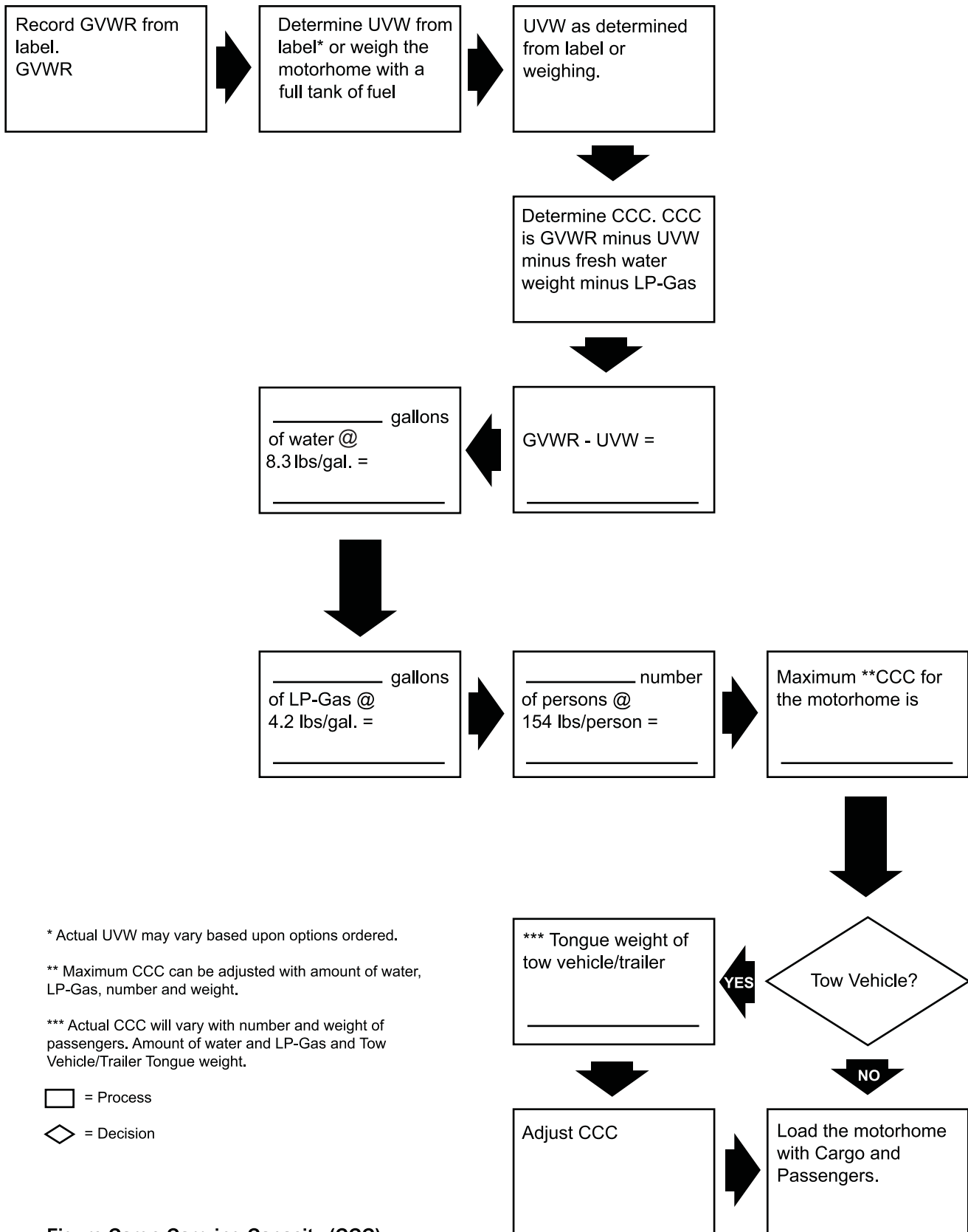

\* Actual UVW may vary based upon options ordered.

\*\* Maximum CCC can be adjusted with amount of water, LP-Gas, number and weight.

\*\*\* Actual CCC will vary with number and weight of passengers. Amount of water and LP-Gas and Tow Vehicle/Trailer Tongue weight.

□ = Process  
 ◇ = Decision

**Figure Cargo Carrying Capacity (CCC)**



	ROADSIDE		CURBSIDE		TOTAL AXLE WEIGHT	GROSS AXLE WEIGHT RATING GAWR	GAWR Minus Total Axle Weight
FRONT AXLE	1. 6,500	+	6,500	=	13,000	13,000	2,500
	2.(A) 5,500		(C) 5,000		10,500		
DRIVE AXLE	1. 10,000	+	10,000	=	20,000	+ 20,000	9,500
	2.(B) 5,500		(D) 5,000		+ 10,500		
			Total Axle Weight	=	21,000 UVW	= 33,000 GVWR	= 12,000 CCC

**NOTE:** These measurements are with a full tank and nobody in the motorhome.

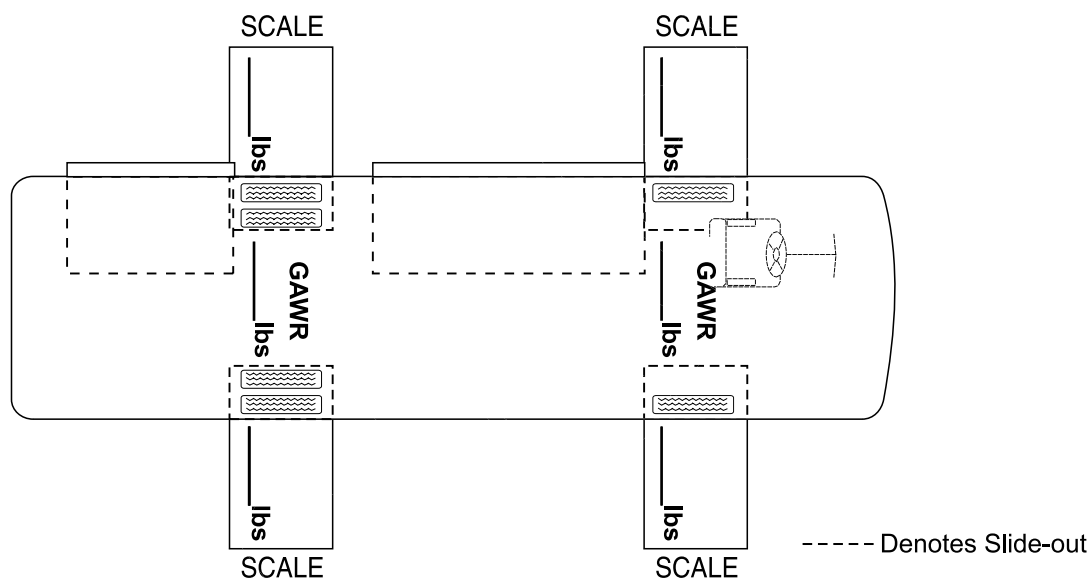

	FORMULA	UVW 23,000 CAPACITY	CCC 12,000
FRESH WATER	Subtract Gallon @ 8.3 lbs/gal	95 x 8.3 = 789	- 11,211
WATER HEATER	Subtract Gallon @ 8.3 lbs/gal	12 x 8.3 = 100	- 11,111
PROPANE	Subtract Gallon @ 4.2 lbs/gal	44 x 4.2 = 185	- 10,926
SLEEP CAPACITY WEIGHT RATING	Subtract Persons @ 154 lbs/person	5 x 154 = 770	- 10,156
		Maximum Cargo Carrying Capacity CCC	10,156

Maximum Cargo Carrying Capacity will change by varying any of the capacities. Tongue Weight of a towed vehicle will reduce the Cargo Carrying Capacity (CCC).

020255b example

	ROADSIDE		CURBSIDE		TOTAL AXLE WEIGHT		GROSS AXLE WEIGHT RATING GAWR		GAWR Minus Total Axle Weight
FRONT AXLE	1.	+		=					
	2.(A)		(C)						
DRIVE AXLE	1.	+		=		+			
	2.(B)		(D)						
			Total Axle Weight	=	UVW	=	GVWR	=	CCC

**NOTE:** These measurements are with a full tank and nobody in the motorhome.

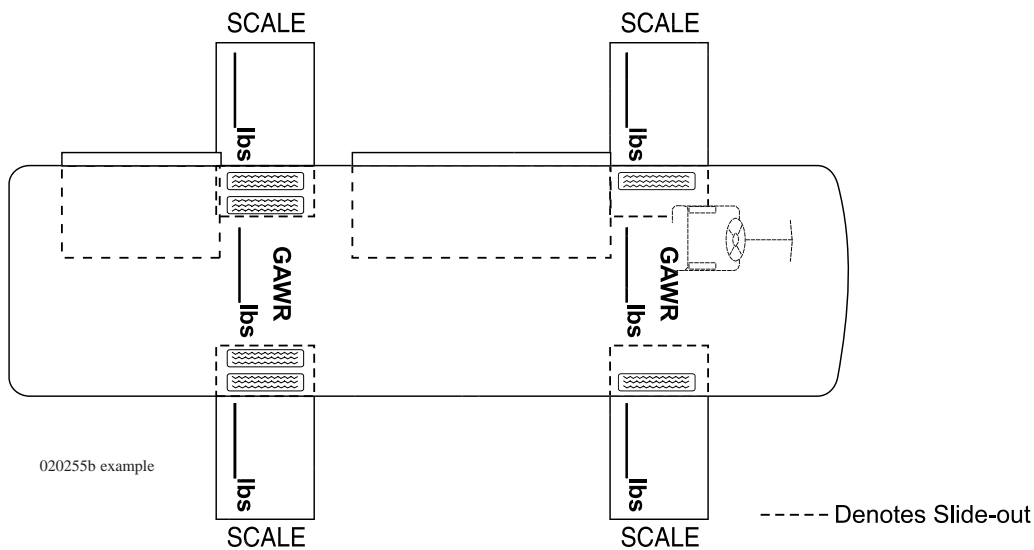

	FORMULA	UVW CAPACITY	CCC
FRESH WATER	Subtract Gallon @ 8.3 lbs/gal	X 8.3 =	-
WATER HEATER	Subtract Gallon @ 8.3 lbs/gal	X 8.3 =	-
PROPANE	Subtract Gallon @ 4.2 lbs/gal	X 4.2 =	-
SLEEP CAPACITY WEIGHT RATING	Subtract Persons @ 154 lbs/person	X 154 =	-
Maximum Cargo Carrying Capacity will change by varying any of the capacities. Tongue Weight of a towed vehicle will reduce the Cargo Carrying Capacity (CCC).		Maximum Cargo Carrying Capacity CCC	

**Weight Record Sheet**

DATE: \_\_\_\_\_

PLACE: \_\_\_\_\_

FRONT: \_\_\_\_\_ + \_\_\_\_\_ = \_\_\_\_\_  
          LEFT                      RIGHT                      TOTAL

REAR: \_\_\_\_\_ + \_\_\_\_\_ = \_\_\_\_\_  
          LEFT                      RIGHT                      TOTAL

= \_\_\_\_\_  
                                  TOTAL GROSS  
                                  VEHICLE WEIGHT

DATE: \_\_\_\_\_

PLACE: \_\_\_\_\_

FRONT: \_\_\_\_\_ + \_\_\_\_\_ = \_\_\_\_\_  
          LEFT                      RIGHT                      TOTAL

REAR: \_\_\_\_\_ + \_\_\_\_\_ = \_\_\_\_\_  
          LEFT                      RIGHT                      TOTAL

= \_\_\_\_\_  
                                  TOTAL GROSS  
                                  VEHICLE WEIGHT

DATE: \_\_\_\_\_

PLACE: \_\_\_\_\_

FRONT: \_\_\_\_\_ + \_\_\_\_\_ = \_\_\_\_\_  
          LEFT                      RIGHT                      TOTAL

REAR: \_\_\_\_\_ + \_\_\_\_\_ = \_\_\_\_\_  
          LEFT                      RIGHT                      TOTAL

= \_\_\_\_\_  
                                  TOTAL GROSS  
                                  VEHICLE WEIGHT

DATE: \_\_\_\_\_

PLACE: \_\_\_\_\_

FRONT: \_\_\_\_\_ + \_\_\_\_\_ = \_\_\_\_\_  
          LEFT                      RIGHT                      TOTAL

REAR: \_\_\_\_\_ + \_\_\_\_\_ = \_\_\_\_\_  
          LEFT                      RIGHT                      TOTAL

= \_\_\_\_\_  
                                  TOTAL GROSS  
                                  VEHICLE WEIGHT

DATE: \_\_\_\_\_

PLACE: \_\_\_\_\_

FRONT: \_\_\_\_\_ + \_\_\_\_\_ = \_\_\_\_\_  
          LEFT                      RIGHT                      TOTAL

REAR: \_\_\_\_\_ + \_\_\_\_\_ = \_\_\_\_\_  
          LEFT                      RIGHT                      TOTAL

= \_\_\_\_\_  
                                  TOTAL GROSS  
                                  VEHICLE WEIGHT

DATE: \_\_\_\_\_

PLACE: \_\_\_\_\_

FRONT: \_\_\_\_\_ + \_\_\_\_\_ = \_\_\_\_\_  
          LEFT                      RIGHT                      TOTAL

REAR: \_\_\_\_\_ + \_\_\_\_\_ = \_\_\_\_\_  
          LEFT                      RIGHT                      TOTAL

= \_\_\_\_\_  
                                  TOTAL GROSS  
                                  VEHICLE WEIGHT

DATE: \_\_\_\_\_

PLACE: \_\_\_\_\_

FRONT: \_\_\_\_\_ + \_\_\_\_\_ = \_\_\_\_\_  
          LEFT                      RIGHT                      TOTAL

REAR: \_\_\_\_\_ + \_\_\_\_\_ = \_\_\_\_\_  
          LEFT                      RIGHT                      TOTAL

= \_\_\_\_\_  
                                  TOTAL GROSS  
                                  VEHICLE WEIGHT

DATE: \_\_\_\_\_

PLACE: \_\_\_\_\_

FRONT: \_\_\_\_\_ + \_\_\_\_\_ = \_\_\_\_\_  
          LEFT                      RIGHT                      TOTAL

REAR: \_\_\_\_\_ + \_\_\_\_\_ = \_\_\_\_\_  
          LEFT                      RIGHT                      TOTAL

= \_\_\_\_\_  
                                  TOTAL GROSS  
                                  VEHICLE WEIGHT

**IEWS - Front**

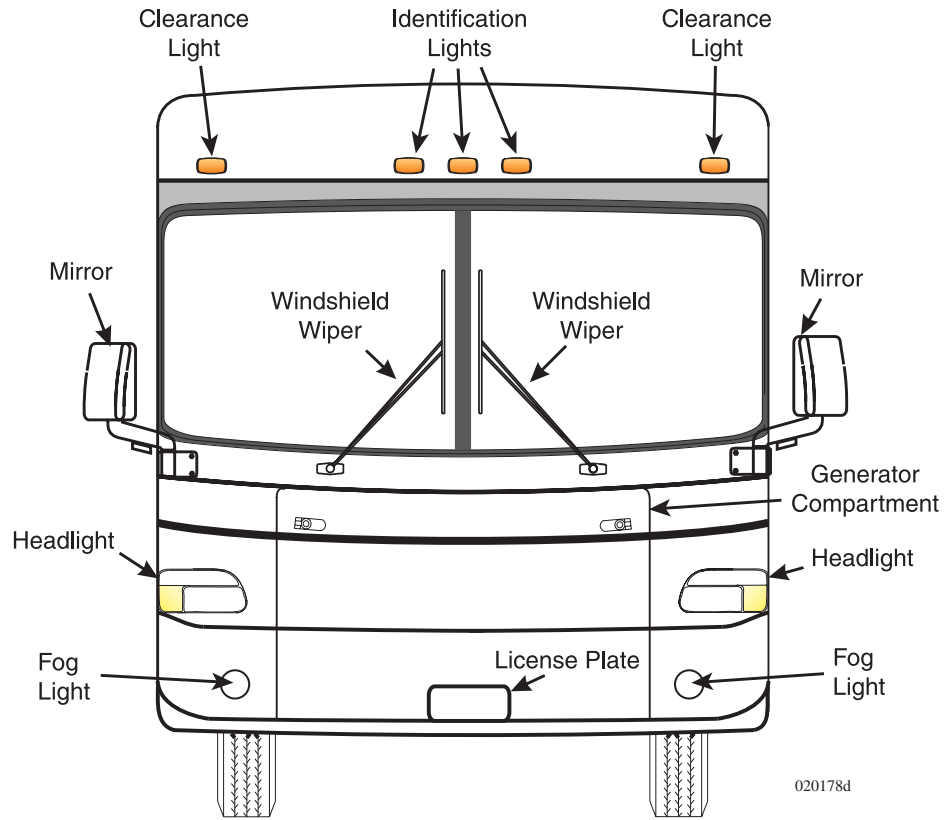

**Rear**

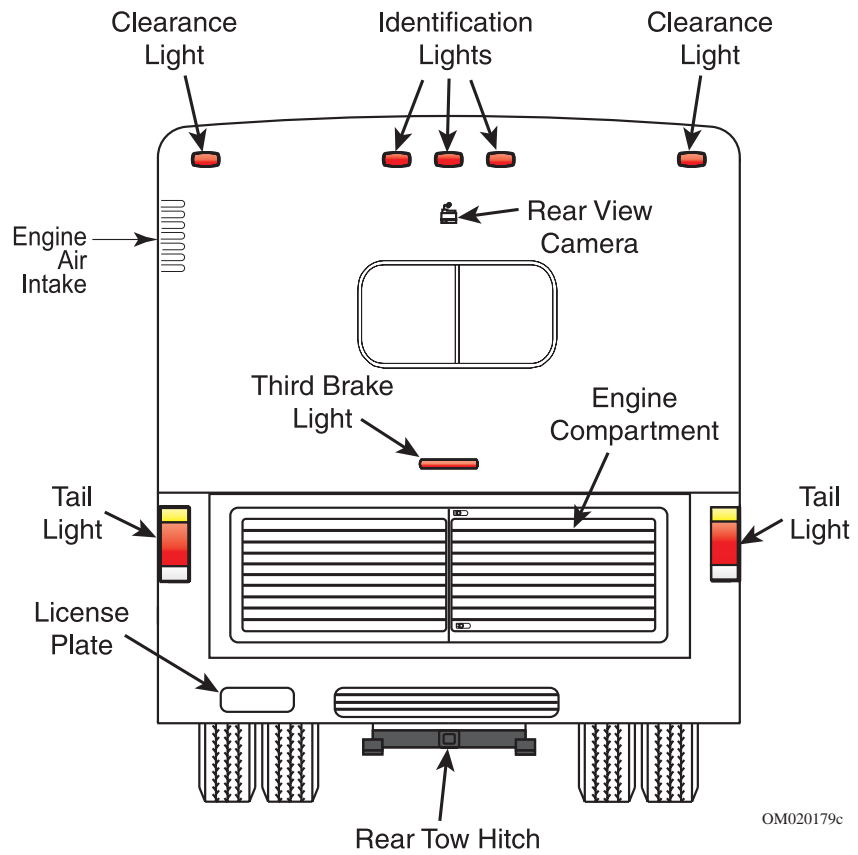

**Roadside**

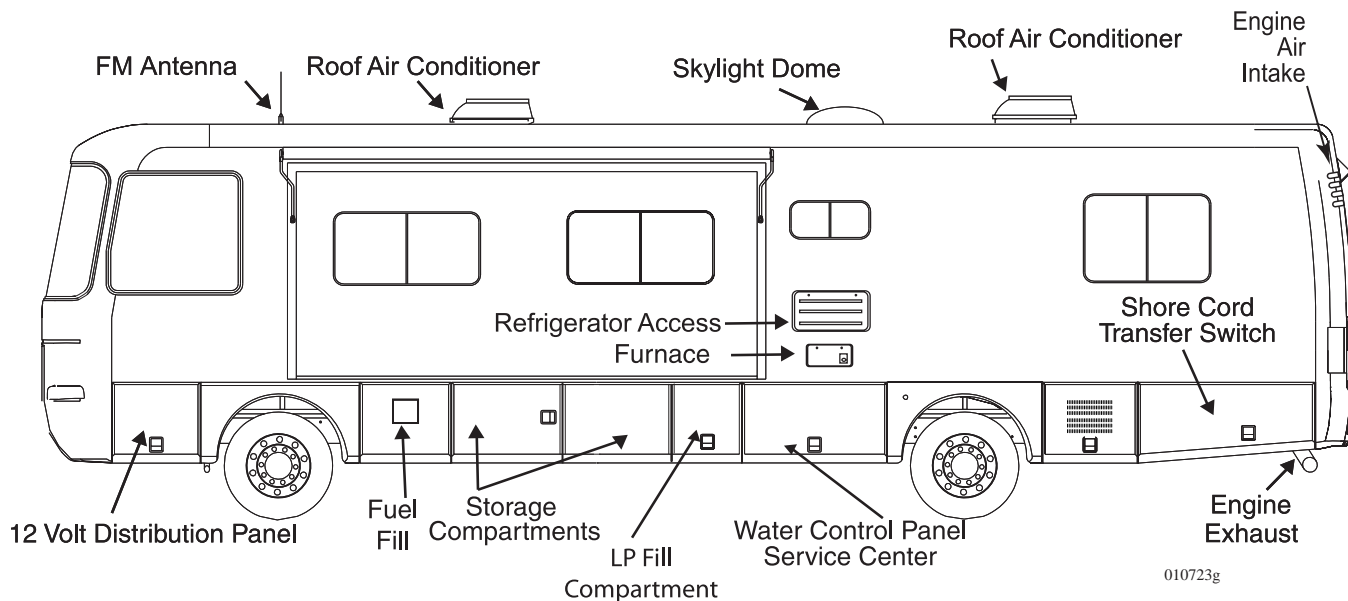

**NOTE:** Difference in models and floor plans may vary locations of items.

**Curbside**

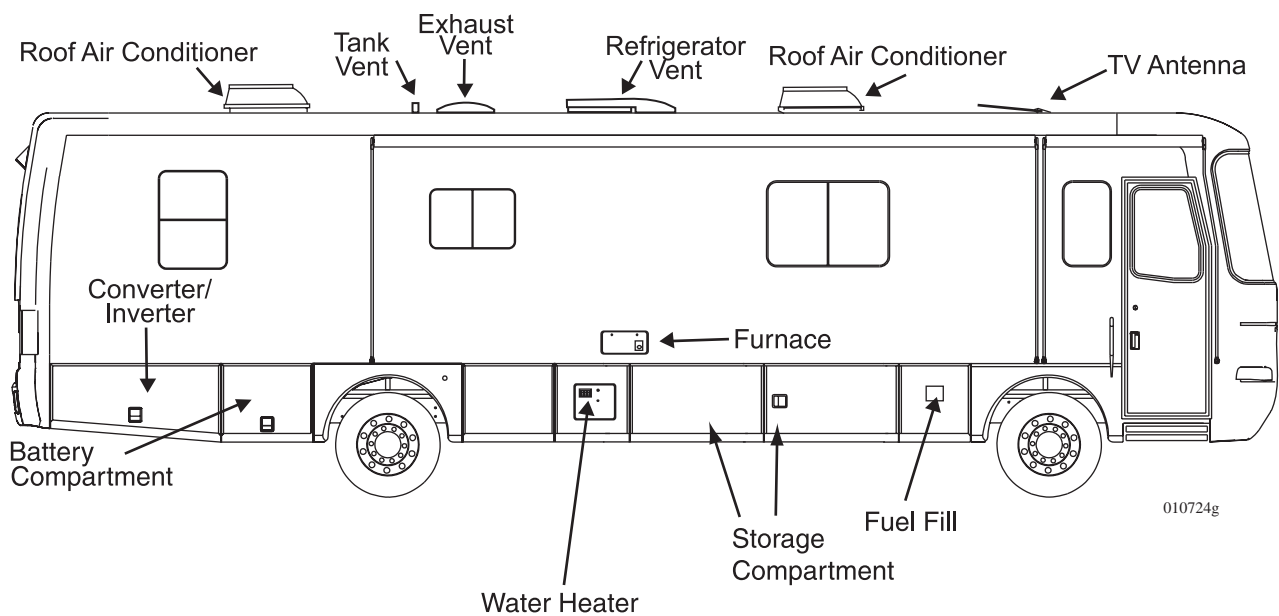

**NOTE:** Difference in models and floor plans may vary locations of items.

---

## SMOKE DETECTOR

Statistics show that most fire casualties are not caused by direct flame, but by less visible smoke (products of combustion). The smoke detector responds to both visible and invisible products of combustion. The smoke detector will automatically return from alarm to normal state when the reason for activation, the presence of smoke, is completely removed. Fires are commonly caused by smoking in bed, leaving children unattended or using flammable cleaning fluids. Please be safety conscious and avoid unnecessary risk.

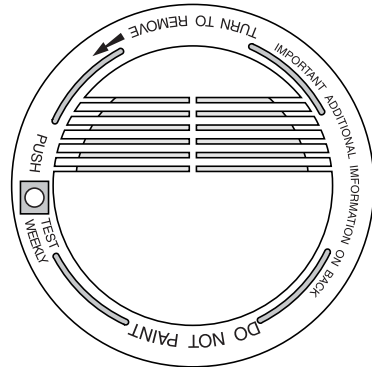

On Ceiling

**WARNING: There is no way to insure there will be no injury or loss of life in a fire; however, the smoke detector is intended to help reduce the risk of tragedy. Additional smoke detectors may help to reduce the risk. Proper use and care of the smoke detector could save lives.**

---

### Operation

When a 9 Volt DC battery is correctly connected, the smoke alarm is operating. The LED will flash every minute showing the battery is supplying power. A load alarm will sound when a production of combustion is sensed.

**NOTE: The unit will not operate without a battery. A battery flag will pop up preventing the unit from being installed to the mounting bracket without a battery. Carbon zinc batteries average a service life of one year. Alkaline batteries average a service life of one to two years.**

---

### Testing

Simply press the test button on the smoke alarm cover for approximately three seconds. The alarm will sound if all electronic circuitry, horn and battery are working properly. The smoke alarm should be tested at least once a week when the motorhome is in use, prior to each trip and when the motorhome has been in storage. When testing the smoke alarm it is advised to stand at arm's length.

**CAUTION: Never use an open flame to test the smoke alarm. You may ignite and set fire to the alarm and to the motorhome.**

A smoke alarm is designed to be as maintenance free as possible. However, there are some simple steps to perform in order to keep the smoke alarm working properly:

- Test the smoke alarm once a week.
- Keep a supply of 9 Volt DC batteries on hand.
- Vacuum the slots in the cover and sides with a soft brush attachment every month. Test the smoke alarm once the unit has been vacuumed.
- The smoke alarm should be cleaned every six months to help keep the unit working efficiently.
- The smoke alarm will beep once a minute when a low battery condition exists. The battery must be replaced immediately.

---

***Troubleshooting***

If the alarm does not sound when the test button is pushed, or with a smoke test, try the following:

- Inspect for obvious damage.
- Check for the recommended battery type.
- Check the battery for proper connection or replace the battery if needed.
- Gently vacuum as recommended.

If these procedures do not correct the problem, do not attempt repairs. If the smoke alarm is within the warranty period and the terms indicate the nature of the problem, return the unit to your dealer. Smoke detectors beyond the warranty period cannot be economically repaired.

## LP-GAS DETECTOR

The LP-Gas detector is required safety equipment in RVs. American National Standards Institute (ANSI) A119.2 - Fire & Life Safety 3-4.8 LP Gas Detectors states " An LP Gas detector must be installed in any RV that contains an LP Gas appliance and an electrical system. The LP Gas detector must be listed as suitable for use in recreational vehicles under the requirement of UL 1484 Residential Gas Detectors, and be installed according to the terms of its listing."

It detects both LP-Gas and methane gas. Liquefied Petroleum (LP) Gas is heavier than air; methane gas is lighter than air. LP-Gas will settle to the lowest point, generally the floor of the motorhome. Methane gas will rise. The gas detector is also sensitive to other fumes such as hair spray, of which most contain butane as the propellant. Butane, like propane, is heavier than air and will settle to the floor level where it will be detected. When this occurs, reset the detector to stop the alert sound.

**About the LP-Gas Detector:** It is important to be aware of the difference between a gas leak versus gas escaping from an unlit, open burner. Pure propane vapors from a leaking pipe or gas fitting are heavier than air and will build up their heaviest concentration at the leak and float down until they mix with air. Gas from open burners is intentionally mixed with air to induce burning and will dissipate into the air. When mixed with air, the gas becomes only marginally heavier than air and will expand outward. If a gas burner is left on, the area around the burner, range, and adjoining counter space will be combustible and can cause injury and damage if ignited. This condition will exist for an extended time period and eventually the gas will reach the detector's location and be detected.

**NOTE: The LP detector only indicates the presence of propane gas at its sensor. Combustible levels of propane gas may be present in other areas. This detector is intended for the detection of propane gas ONLY.**

It has not been tested to detect any other gas. However, other volatile gases (nuisance gases), most of them flammable in various concentrations, may cause the detector to alarm. Some products that may cause the detector to alarm are alcohol, liquor, kerosene, gasoline, deodorants, colognes, propellants used in spray cans and cleaning solvents. In some cases vapors from the glues and adhesives used in the manufacturing of the motorhome may also cause the detector to alarm for several months after the date of manufacture. If it is determined that the detector has false alarmed because of the above mentioned nuisance gases, reset the detector and air out the vehicle with fresh outside air.

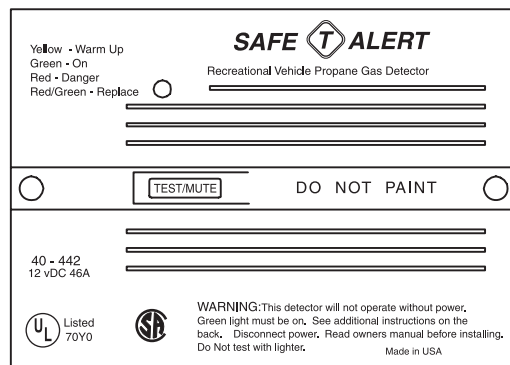

*On Wall Next to Floor*



Take precautions to be sure one of these nuisances has not masked an actual gas alarm condition. The detector draws less current than one instrument panel lamp. The detector will operate to detect gas until the battery is drained down to 7.0 Volts. The detector must be supplied with a voltage higher than 7.0 Volts, for it to operate properly. If the power source is disconnected, or if the power is otherwise interrupted, the detector will not operate.

The LP-Gas leak detector has a self-check circuit which runs at all times while the detector is powered. In the event that the circuitry fails, a failure alarm will sound and the operating indicator will cease to light.

**LP-Gas Detector Operation:** Upon first application of power the LED will flash yellow for three minutes while the detector is stabilizing. At the end of the start cycle the LED will turn Green, indicating full operation. If the detector senses unsafe levels of gas it will immediately sound an alarm. The gas detector operates on 12 Volt DC, with a current draw less than 1/10th of one amp.

**CAUTION: The detector will not alarm during the three minute warm up cycle.**

---

### ***Testing***

Press the **TEST** switch any time during the warm up cycle or while in normal operation. The LED should flash red and the alarm should sound. Release the switch. This is the only way the detector should be tested. The test feature checks full operation of the detector.

**WARNING: Test the operation of this detector after the motorhome has been in storage, before each trip and at least once per week during use.**

---

### ***Alarm***

The **red** LED will flash and the alarm will sound whenever a dangerous level of propane or methane gas is detected. The detector will continue to alarm until the gas clears or the **Test/Mute** switch is pressed.

**Procedures to Take During an Alarm:**

1. Turn off all gas appliances, (stove, heaters, furnace), extinguish all flames and smoking material. Evacuate, leave doors and windows open.
2. Turn off the propane tank valve.
3. Have a qualified professional determine and repair the source of the leak.

**CAUTION: Do Not re-enter until the problem is corrected.**

### Potential Sources of LP Gas Leaks When Operating the Motorhome:

- Cooktop Burners
- Water Heater
- Oven
- Defective Regulator
- Furnace
- Defective LP-Gas Connection
- Refrigerator
- Portable Propane Powered Equipment

**Alarm Mute:** Press the **Test-Mute** button when the detector is in alarm.

1. The **red** LED will continue to flash and the alarm will beep every 30 seconds until the gas level has dropped to a safe level.
2. The LED will flash **green** until the end of the **Mute** cycle.
3. If dangerous gas levels return before the end of the **Mute** cycle, the alarm will beep four times and return to phase 1.
4. After two minutes the detector will return to normal operation (solid **green**) or resound the alarm if dangerous levels of gas remain in the area.

**Fault Alarm:** Should the microprocessor sense a fault in the gas detector, a fault alarm will sound twice every 15 seconds. The LED will alternately flash **red to green** and the **MUTE** switch will not respond to any command. The gas detector must be repaired or replaced.

---

### Maintenance

1. Vacuum the dust off the detector cover weekly (more frequently in dusty locations) using the soft brush attachment of the vacuum.
2. Do not spray cleaning agents or waxes directly onto the front panel. This action may damage the sensor, cause an alarm or cause a detector malfunction.

---

## CARBON MONOXIDE DETECTOR

American National Standards Institute (ANSI) A119.2 - Fire & Life Safety 3-4.6 Carbon Monoxide Detectors states "All RVs equipped with an internal combustion engine or designed with features to accommodate future installation of an internal combustion engine and truck campers shall be equipped with a listed CO detector installed in accordance with its listing."

The motorhome is equipped with such a carbon monoxide detector. Everyone is at risk with Carbon monoxide poisoning. Carbon monoxide (CO) is a colorless, odorless and tasteless gas that binds with hemoglobin reducing the body's ability to absorb and carrying oxygen to vital organs. Even low levels of CO have been known to cause brain and other vital organ damage in unborn infants, with no effect on the mother.

When removed from exposure, the symptoms dissipate as Carbon Monoxide is expelled through the lungs. Level of contamination in the body reduces at half-life increments at approximately four-hour intervals. Treatment with Oxygen will quicken recovery time.

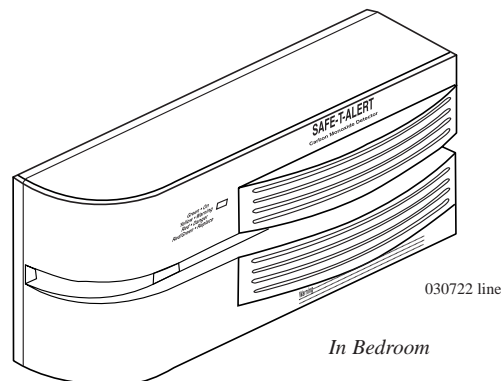

In cases of mild exposure, the symptoms may include: a slight headache, nausea, vomiting and fatigue, or "flu-like symptoms." Symptoms for medium exposure may include a severe throbbing headache, drowsiness, confusion and fast heart rate. Extreme exposure can result in unconsciousness, convulsions, cardio-respiratory failure and death. Young children and household pets may be the first affected. Other highly sensitive people would include the elderly and people with lung or heart disease or anemia. The CO detector is designed to detect the toxic CO Gas resulting from incomplete combustion of any fuel, including gasoline, propane, natural gas, oil, charcoal or wood. Anything that burns fuel (engines, generators, furnaces, gas stoves or water heater) produces CO gas. Consequently, it is uncommon for household smoke from cigarettes or normal cooking to cause the alarm to sound.

**CAUTION: Activation of this device indicates the presence of potentially fatal carbon monoxide (CO). A concentration of more than 100 PPM will cause a warning condition. Individuals with medical problems may consider using detection devices with lower carbon monoxide alarming capabilities. Prolonged exposure to the horn at a close distance may be harmful to hearing.**

The CO detector is wired to both the house and chassis batteries, allowing reliable and continuous protection by warning of the build up of potentially dangerous levels of CO. Once the unit is powered, it will run through a brief warm-up and self-check prior to monitoring for CO gas. The detector cannot be accidentally turned off. A simple test procedure should be performed to ensure the CO detector is properly functioning.

**WARNING: If there is constant beeping and the red light is flashing, CO gas has been detected. Shut off appliances, coach engine, and water heater. Evacuate the coach and call the fire department. Have any problems corrected before restarting any appliances or the coach.**

---

## *Operation*

The detector is equipped with a self-cleaning CO sensor and requires a ten minute initial warm-up period to clean the sensor element and to stabilize. During the warm-up period, the **green** power light will flash **ON** and **OFF**. The **green** power light should be lit when the power is on. If it is not, turn off the power and check all wire connections. If the power is on and the connections are correct, but the indicator does not light, return the detector for service. **Do not attempt to fix the detector.**

The indicator light displays a specific color to monitor along with a matching sound pattern:

### **Indicator Lights and Sound Patterns:**

- **ON** or normal condition is indicated by **green**. The CO detector has power and is sensing air for the presence of CO gas. The alarm horn will not sound.
- Flashing **red** indicates low CO Alarm condition along with 4 beeps then **OFF** for 5 seconds. The alarm horn will sound and can be reset by the **TEST/RESET** button. The CO detector has detected the presence of 70 ppm.
- Steady Red indicates a **CO ALARM** condition. The detector has sensed the presence of levels over 100 ppm of carbon monoxide. The alarm horn will sound continuously until the **RESET** switch is reset.
- Alternating red and green indicates a malfunction alarm.

## Alarm

When the alarm sounds have the detector and the motorhome checked by an authorized service technician as soon as possible. Never disconnect a CO detector to silence an annoying alarm. Evacuate the motorhome immediately when the **red** light is lit and the alarm sounds. Do a head count to check that all persons are accounted for. Call the nearest fire department and ask them to determine the source of the carbon monoxide. Do not re-enter the motorhome until it has been aired out and the problem corrected.

### Potential Sources of CO when operating the motorhome:

- Engine Exhaust
- Portable Grills
- Other Motorhomes
- Portable Space Heaters
- Defective Engine Exhaust System
- Generator Exhaust
- Camp Fires
- Portable Generators
- Gas Stoves and Ovens

---

## Testing

**Test Procedures:** Test the carbon monoxide detector operation after the motorhome has been in storage, before each trip and at least once a week during use. Test the alarm by holding the **TEST/RESET** button in until the alarm sounds. The alarm will sound 4 beeps and the indicator lamp goes steady **red**. Six seconds later the alarm will again beep 4 times and the indicator light goes steady **green**.

**Peak Level Memory:** The CO detector has the capability to remember the level of carbon monoxide that activated the alarm. Press the **TEST/RESET** button for less than one second and observe the visual and audible signals.

- One beep and a green flash indicate memory is clear.
- Two beeps and two red flashes indicate less than 100 ppm.
- Three beeps and three red flashes indicate less than 200 ppm.
- Four beeps and four red flashes indicate greater than 200 ppm.

**NOTE:** Memory is erased when power is disconnected for 15 seconds.

---

## Cleaning

Use a vacuum cleaner to remove dust or any other buildup on the detector. Do not wash. Wipe the detector with a damp cloth and dry with a towel. Do not open the detector for cleaning. Do not paint the detector. It is recommend that the carbon monoxide detector be replaced every 10 years.

---

## Troubleshooting

The CO detector has **NO** user service parts. If there is a problem with the detector refer to an authorized service center. **DO NOT REMOVE POWER.**

**NOTE:** Check the CO detector weekly and at the beginning and end of each trip.

## FIRE EXTINGUISHER

The fire extinguisher in the motorhome is located near the main entrance door. Please read the operating instructions that are printed on the fire extinguisher. If there is any doubt on how to operate the fire extinguisher, you and your family should practice using it. Be sure to replace or recharge the extinguisher immediately after use.

**Inspect** the fire extinguisher at least once a month. Do so more frequently if the extinguisher is exposed to weather or possible tampering. Do not test the extinguisher by partially discharging. Internal pressure will escape and the fire extinguisher will need to be replaced.

Use the **PASS** word!

**Pull** the pin to unlock the extinguisher.

**Aim** at the base (bottom) of the fire and stand 6-10 feet away.

**Squeeze** the lever to discharge the agent.

**Sweep** the spray from left to right until totally extinguished.

**WARNING:** Road vibration will cause extinguisher powder to compact and may cause extinguisher malfunction. Invert and shake extinguisher monthly.

### Classes of Fire:

**A** - Fire that is fueled by materials that leave a residue when they burn: paper, wood, cloth, rubber, and certain plastics.

**B** - Fire that involves flammable liquids and gases: gasoline, paint thinner, kitchen grease, propane and acetylene.

**C** - Fire that involves energized electrical wiring or equipment. If electricity to the equipment is turned off, a class C fire becomes one of the other two class fires.

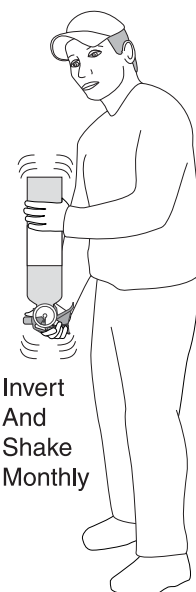
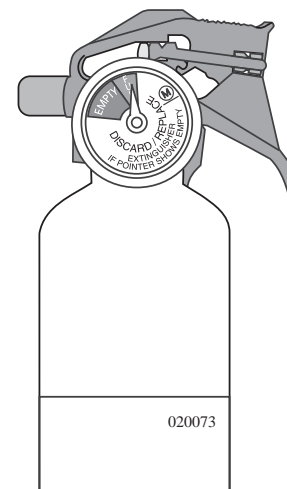

020261

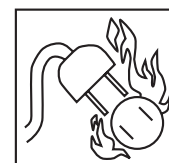

100209

## EGRESS (EXIT) WINDOW

An egress window is designated for use as an exit in the case of an emergency. Inside the motorhome the egress window is easily identified by the red locking handle. It is also marked as an "EXIT." The glass slider in the egress window operates the same as all other windows.

- To open the egress window, lift the red handle and push outward on the window.
- To close the egress window, pull the window closed and lower the handles to lock window in place.

**CAUTION:** The egress window should be opened twice a year to ensure proper operation. Over time, the rubber seal will tend to stick to the egress window. Occasional operation will help prevent the rubber seal from sticking.

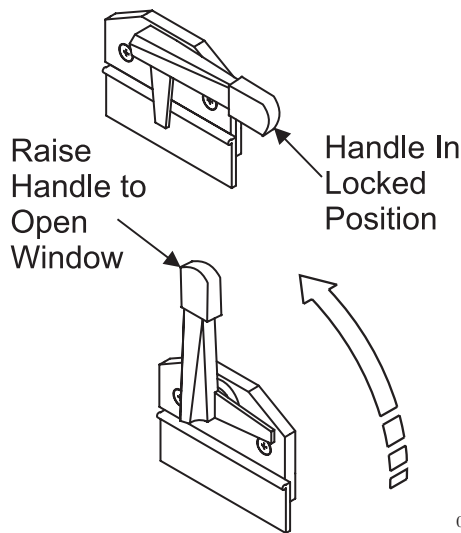

020029

Egress Window Handle

~ **NOTES** ~

---

---

---

---

---

---

---

---

---

---

---

---

---

---

---

---

---

---

---

---

---

---

---

---

---

---

---

---





# Exterior & Interior Care

## Section 3

<b>EXTERIOR CARE</b> .....	<b>99</b>
Corrosion .....	99
Washing .....	99
Drying .....	100
Waxing .....	100
Paint Codes .....	101
Tire Care .....	101
Aluminum Wheels (Opt).....	102
Bright Metal.....	103
<b>EXTERIOR MAINTENANCE</b> .....	<b>104</b>
Roof Care & Seal Inspections .....	104
<b>INTERIOR CARE</b> .....	<b>106</b>
Cockpit.....	106
Fabrics .....	106
Fabric Cleaning Codes .....	107
Fabric Specifications Charts .....	109
Vinyl.....	110
Leather.....	112
Ultra-Leather .....	113
<b>FLOORS</b> .....	<b>114</b>
Carpet Cleaning .....	114
Tile Floors .....	116
Laminate Floors (Opt).....	116
<b>SHOWER</b> .....	<b>117</b>
<b>CEILING</b> .....	<b>118</b>
<b>WALL COVERINGS</b> .....	<b>119</b>
<b>WOOD CARE</b> .....	<b>120</b>
<b>COUNTERTOPS - SOLID SURFACE</b> .....	<b>122</b>
Laminate .....	123
Stainless Steel Surface .....	123
<b>WINDOWS</b> .....	<b>123</b>
Condensation .....	123
<b>WINDOW TREATMENTS</b> .....	<b>124</b>
Mini-Blinds .....	124
Day/Night Shades (Opt) .....	125
<b>MOLD &amp; MILDEW</b> .....	<b>125</b>
<b>PEST CONTROL</b> .....	<b>127</b>
<b>STORAGE</b> .....	<b>130</b>
Short Term .....	130
Long Term.....	130
Winter Storage - Checklist .....	133
Removal from Storage.....	134



---

**EXTERIOR CARE - Corrosion**

The most common cause of corrosion to the motorhome is the accumulation of road salts, grime and dirt. These elements, combined with moisture, may possibly cause early component failure. Salt air and fog from coastal trips can greatly accelerate the corrosion process. Corrosive materials collected from roadways accumulate on the undercarriage, around wheel openings and on the radiator charge air cooler package. These areas need to be cleaned periodically to help prevent component failure due to corrosion. If the motorhome is driven in areas where road salts are used it should be washed at least once a week. Otherwise, it is recommended to hose off the undercarriage area at least once a month to help minimize the corrosion process. High pressure washers or steam cleaners are the most effective way of cleaning off the underside and inside wheel openings. **Avoid directly spraying the painted surface with a high pressure washer.** Remove road debris and mud that has accumulated. Material left behind can intensify the corrosion problem.

**CAUTION: Exercise caution when cleaning the radiator charge air cooler package. Damage to the fins can result when using a high pressure washer or steam cleaner. Nozzle discharge pressure can exceed 1800 psi. Avoid using high pressure steam cleaners on the exterior paint surfaces. Remove all spattered washing debris from the exterior paint surfaces as soon as possible.**

---

***Washing***

Periodic cleaning will help preserve the paint finish. The motorhome is painted with a “base coat, clear coat system.” The clear coat is a polyurethane based material which brings out the shine or luster to the base coat paint. Care should be used when washing the motorhome. Use only mild detergents or preferred specifically designed automotive detergents. Avoid using abrasive cleansers or laundry detergents as they will scratch the clear coat and leave a soap film. The use of specially designed automotive washing utensils, such as soft bristle brushes, are acceptable as long as they do not trap abrasive material and scratch the surface while being used. Before washing the motorhome remove most of the accumulated dirt and “road wash” behind wheel openings, below the windshield and on the rear of the motorhome. If the build up is excessive, run water over a soft brush while gently scrubbing the surface in one direction. This will help float away the “build-up” from the clear coat. Avoid back and forth or circular motions as this may act like sandpaper, scratching the clear coat and leaving a haze or “swirl marks.” After removing the heavy build-up, use the mixed detergent solution to wash the motorhome. Start washing at the top of the motorhome working towards the bottom. If possible, wash the motorhome in a shaded area when the exterior is not hot to the touch. If necessary, turn the motorhome around to keep the area being washed in the shade. Try not to allow the detergent to dry onto the clear coat surface. Use plenty of water when rinsing the surface to remove any detergent residue.

## **Drying**

Drying chamois cloths come in natural and synthetic materials. Either type is acceptable as long as the surface is clean. Soak the chamois in clean water until all chamois material has absorbed water. Wring excess water from chamois. Start at the top and work towards the bottom. Use a downward “S” pattern to remove water from the surface and wring out the chamois as needed. Using a chamois cloth to remove the rinse water is not necessary, but the effort can be worthwhile.

---

## **Waxing**

**It is recommended to wax the motorhome twice a year: spring and fall.** Many types of protective barriers are available today that may be applied to the clear coat: glazes, waxes, polishes, a rubbing compounds or combinations of these products.

**NOTE: Use a grease and wax remover before applying another coat of wax. Chemicals can become trapped between layers of wax possibly damaging the paint finish.**

**INFORMATION: When selecting a product for use follow the product manufacturer’s recommended application instructions.**

### **Types of Products:**

**Glazes:** Glazes are generally used to fill very fine scratches in the clear coat, being applied either by hand or by using a polisher with a special pad.

**Waxes:** Waxes come in many types of chemical make-ups. The popular Carnauba wax is a natural occurring wax from the leaves or fronds of the Carnauba palm tree. Mineral waxes have a paraffin base. There are also other topical application products which contain silicone.

**Polishes:** Polishes usually contain a combination of wax based substances with an abrasive, getting the two for one idea. These products can be too abrasive for clear coats and are not recommended for use.

**Rubbing Compounds:** These types of products are generally applied by using a buffer. The use of rubbing compounds should be left to professionals as undesired results can quickly occur. These types of products are generally used to correct or flatten a surface by removing high spots or small amounts of material.

When selecting a product the container should be marked, “safe for clear coats” or “clear coat safe.” Carefully follow all manufacturer’s application instructions when using a product. Upon first use of a product, try it on a “small test spot” in an inconspicuous area in case an undesired reaction occurs.

Observe the test area from different angles checking for hazing or swirl marks. If an abnormal reaction to the finish occurs, discontinue product use and consult the product’s manufacturer. If the product is a paste, do not allow dried paste to be baked on by the sun. Remove paste shortly after drying. Clean, dry, 100% cotton cloths or cotton baby diapers are best suited for the removal of dried paste. Turn the cloth often. Use a separate clean cloth to buff. The surface should feel “slick” when rubbing the cloth lightly over it. Avoid repeated wax applications which can cause wax to build up. Some very fine scratches or swirl marks may be removed by an application of a glaze. These types of glazes fill the scratches or swirl marks.

The motorhome has a large surface area. Washing and waxing may not be completed in one afternoon. Select sections to wax until the motorhome is complete. If the task seems overwhelming, have an automotive detailer perform the task.

---

### ***Paint Codes***

The motorhome has a color scheme comprised of different colors. Each of these colors in the color scheme has been assigned a paint code. The paint code is a formula used to mix different colors to achieve a desired color of paint. It may be necessary to obtain "Touch-up" paint to repair a small imperfection in the paint surface. However if it becomes necessary to paint a larger area, it will be necessary to obtain the paint code to get the correct color.

#### **To Obtain the Paint Code:**

1. Contact National Parts @ 1-877-466-6226
2. Specify the year, model, serial number and exterior color scheme name (if known).
3. Once the paint code has been obtained for the desired color, contact Industrial Finishes @ 1-800-531-1305. They will use the paint code to get the mixing formula.
4. This formula can be mixed at a local BASF paint store.

**NOTE: All special paint schemes require contacting Monaco Coach directly for paint codes.**

---

### ***Tire Care***

Road oil will cause deterioration of the rubber. Dirt buildup will help hold chemicals in the air next to the tire and will also cause deterioration.

When cleaning any rubber product, proper care and methods in cleaning must be used to obtain the maximum service years out of the tires. Use a soft brush and a mild detergent to clean the tires. If a dressing product is used to “protect” the tires from aging, use extra care and caution. Tire dressings that contain petroleum products or alcohol may cause deterioration or cracking.

In many cases it is not the dressing that causes a problem but the chemical reaction that subsequently occurs. When these same dressing products are used on a passenger car tire that is replaced every three to four years, it is rare to see a major problem. However, in most cases recreational vehicle tires may last longer due to limited annual mileage and exposure.

## **Aluminum Wheels (Optional)**

General Cleaning and Polishing Procedure to maintain machined and polished aluminum wheels or polished aluminum wheels.

Aluminum wheels or polished aluminum wheels should be cared for the same as the painted finish of the motorhome. Regularly clean the polished aluminum wheels are recommended to keep the wheel finish bright and shiny. The use of an aluminum wheel polish or carnauba wax will protect the polished wheel surfaces. It will also help prevent corrosion and pitting of the aluminum wheel surfaces caused from natural environmental contamination and will make future cleaning and polishing easier.

**Outside:** Follow these simple steps to keep the polished aluminum wheels looking their best:

1. High-pressure water is recommended to rinse the wheel to remove any debris, grit or dirt particles.
2. A 100% cotton cloth dipped in a mild soap solution is used to help remove built up dirt and grease.
3. The remaining soap residue is rinsed from the wheel using high-pressure water.
4. Dry the wheel thoroughly with a 100% cotton cloth.
5. Use an aluminum wheel polish to remove spots and stains from the surfaces of the wheel as necessary.
6. Apply carnauba wax to the visible wheel surfaces. Carnauba wax should be reapplied on a regular basis to maintain wheel luster.

**NOTE: Allow wheels to cool before spraying with cold water.**

**CAUTION: Begin washing wheels by rinsing off loose particles using high-pressure water. Synthetic cleaning pads can result in streaking of the polished aluminum surface. Using wire brushes to remove dirt or grime can scratch the wheel surface. Strong detergents, alkaline or acidic cleaners can etch the surface of the aluminum and leave dull areas. Soap solution allowed to dry on the surface can dull the wheel finish. Do not apply abrasive polishes to the aluminum wheels.**

### **Wheels - Coated (ACCU-SHIELD)**

**Outside:** The coated surface of the wheels should be treated the same as the paint finish on the motorhome. Road soils, grime and break dust trap moisture which can cause corrosion over a period of time.

1. Clean frequently with high-pressure water.
2. Using a 100% cotton cloth and a mild soap solution (dish soap or car wash soap is recommended) to speed up the cleaning process.
3. Rinse all remaining soap residue with high-pressure water and wipe dry using a 100% cotton cloth to avoid water spots.
4. A secondary hand washing may be required to remove some stubborn road films.
5. Carnauba wax can be applied to help protect the finish.

**NOTE:** Allow wheels to cool before spraying with cold water.

**CAUTION:** Use only polishes marked “Safe for Clear Coat” or Alcoa Aluminum Care. Strong detergents made from alkaline or acidic cleaners used to clean the ACCU-SHIELD aluminum wheel can attack the surface of the wheel and leave dull areas. Do not clean the polished surface of the wheel with abrasives, abrasive brushes, steel wool, scouring pads, synthetic cleaning pads or strong chemicals such as acids or lye-based products. Use of strong solvents to remove grease or grime from the surface of the wheel can cause damage to the wheel surface finish.

Minor imperfections in the coating can usually be repaired. Contact Accuride for “Accuride Technical Bulletin 2.0038” at 1-800-823-8332.

**Inside:** If the tires are removed, inspect and clean the entire rim. Air used to fill the tire may contain moisture that can cause the areas of the wheel under the tire to corrode. Use a brush, to remove foreign material from the tire side of the rim. Lubricate the rim and tire bead with a non-water-based lubricant before mounting the tire. Insure the inside of tire is dry before installing.

**NOTE:** For further information contact Accuride at 1-800-823-8332.

**WARNING:** Do not use a flammable solution to coat the inside of the rim. This can lead to an explosion during tire inflation or in subsequent operation of the motorhome.

---

### ***Bright Metal***

All chrome, stainless steel and aluminum should be washed and cleaned each time the motorhome is washed. Use only automotive approved non-abrasive cleaners and polishes on exterior bright work. Aluminum wheels should be cleaned regularly with a non-abrasive cleaner recommended for aluminum wheel care. Do not use rubbing compounds. Do not use any abrasive cleaners or compounds to clean the mirrors.

**NOTE:** When using chemicals to remove road tars, use only automotive type products that are recommended for use on painted surfaces and fiberglass. Observe the warning recommendations and directions printed on the container of any agent being used.

## EXTERIOR MAINTENANCE

The motorhome is subject to a great deal of outside conditions. While the coach is parked it is exposed to extreme temperatures, humidity, ultraviolet rays, acid rain and other organic environmental conditions. While in operation the coach is subject to twisting and flexing caused by (for example) going in and out of driveways, bouncing through potholes and driving through winding mountain roads.

**Inspect** the fiberglass exterior. Periodic inspections may reveal minute cracks in the surface commonly called “spider cracks” or “hairline cracks” which are caused by the flexing of the fiberglass exterior. These are normal. If a crack represents a threat to the integrity of the fiberglass it will open up and the weave of the cloth would be visible. If the exterior has been damaged, prevent moisture penetration, especially in freezing climates. Cover the area as quickly as possible. Use plastic sheeting and tape, if necessary, so that moisture will not get into the motorhome and damage the interior.

---

### ***Roof Care & Seal Inspections***

Periodic resealing of the joints and seams is necessary to prevent the entrance of moisture into the motorhome. Enough emphasis cannot be placed on this issue. Extreme damage from a water leak can occur rapidly. Never leave the vehicle unattended with the slide room extended. If the vehicle is to be stored outside throughout the winter months, a full interior inspection for water leaks should be made bi-monthly.

Extensive sealing has been done at the factory; however, the normal twisting and flexing that occurs while traveling may have compromised a seal or seam.

**INSPECT: All joints and seams should be inspected at least twice a year and recalced as necessary.**

Special attention should be directed toward the roof air conditioning seals, ceiling and plumbing vents, skylights, roof mounted antennas, windows, door molding, clearance lights and the beltline molding.

Specific sealant products should be used in the areas for which they were designed. These items can be obtained from recreational vehicle parts suppliers. Listed below are some of the more common sealants and the areas in which they are used. Approved sealants are available at service centers and authorized dealers.

**WARNING: Some products may contain hazardous materials which require special handling. Read labels carefully. Follow all of the product manufacturer’s safety requirements.**



**Sealant Types:**

**Acryl-R:** Acryl-R is used on all roof openings such as vents, skylights, any roof mounted antennas and ladder roof mounts. The sealant should be applied only where the equipment bases meet the roof. Clean the old sealant that is lifting before applying the new. Make sure the roof is dry and free of dirt. This product is usually found in a caulking tube. Care should be used when near an edge, as the product will spread out. Masking tape may be used to mask around area to avoid mishaps. The roof air conditioners use a closed cell foam base gasket. No sealants are required. The roof air conditioners should be checked for tightness by the four mounting bolts located in each interior corner of the air conditioner roof opening. Torque specification is 40-50 in/lbs. The base gasket should be compressed to approximately one half inch.

**Acrylic Sealants (Geocel 2300):** This product is used where items are sealed under a painted surface such as the metal corners of the slide-out room. The material is specially formulated to allow paint adhesion.

**Black Urethane:** Used for sealing the windshields, not to fill holes or other imperfections. Black urethane comes in a tube and it applies much the same way as silicone. Clean up using solvents such as paint thinner. Gloves are required as this material is hazardous.

**Silicone Sealant:** Primarily used on the sidewalls where a hole has been made and an item installed. This includes Windows, Doors, Handles, Beltline Molding, Latches and around bases of items surface mounted such as clearance lights. Old peeling sealant should be removed. Avoid using metal utensils which can scratch the painted surface. Use nylon sticks or equivalent. Avoid using lacquer thinners or ketone based solvents as these chemicals can damage the painted surfaces. Be sure the surface is clean and dry before application. Cut the tube at an angle with smallest usable opening. Avoid a heavy bead as a little goes a long way. Use finger at a 45° angle on beaded surface to smooth out product. Do not moisten finger, use a disposable latex glove. Keep rags or paper towels handy for clean up. Use care when applying silicone. Plan ahead before starting a bead, look for obstacles that may impede application.

**Spray Foam:** Used as a sealant where a hole has been made for items such as water lines or wires that are coming through a floor opening.

## INTERIOR CARE - *Cockpit*

The cockpit area dashboard is a molded fiberglass vinyl wrapped pod. The instrument panel is comprised of various gauges and switches. The dashboard and instrument panel each have different cleaning requirements. Clean the vinyl wrapped dash pod following the instructions under *Vinyl Care* in this section. In the event a blemish or small cut occurs in the vinyl, contact a professional upholstery repair service.

Clean the plastic or Plexiglas instrument panels using a cloth dampened in a mild soap and water solution. Dry using a separate cotton cloth. Plastic polish products that will help to brighten the appearance of plastic or Plexiglas instrument panels are Novus Plastic Care<sup>®</sup>, a three-part system; Meguires<sup>®</sup>; and Johnson Paste Wax<sup>®</sup>, which will require extensive buffing and rubbing.

Glass lens gauges can be cleaned using glass cleaner. Spray cleaning on the cloth, not directly onto the lens, to prevent over spray or runoff .

**CAUTION: Most glass cleaning products are volatile to plastics; extreme care must be used to prevent the glass cleaners from contacting the plastic, making the plastic brittle and dulling the finish.**

**TIP: To determine if the lens is glass or plastic, simply tap the lens with a fingernail. Plastic lens will have a dull hollow sound whereas glass will have a clear ping.**

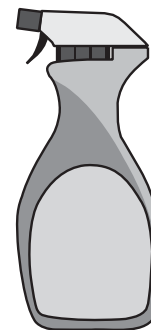

*cleaner*

---

## *Fabrics*

Most fabrics have a designated cleaning code assigned to them. The cleaning code is determined, in most cases, by the content of the fabric. The code represents the cleaning agent and method that is approved by the fabric industry. If the fabric is abused, it can be damaged. Special care needs to be taken when the motorhome is exposed to a very humid climate for an extended period of time. Cover all upholstery and make sure window coverings are down to protect from sun damage.

Protect the fabric from any unnecessary exposure to moisture. Frequently used items will wear accordingly and may require more attention than those items not regularly used.

---

**Use the following guidelines for cleaning upholstery fabrics.**

- Water-based cleaners are not recommended.
- If a spill does occur, blot the soiled area. Do not rub it.
- Some solvents are not recommended since they may have an adverse reaction on a specific backing of the upholstery fabric.
- To prevent overall soiling, frequent vacuuming or light brushing are recommended to remove dust and grime.
- Clean spots using a mild water-free solvent or dry cleaning product.
- Clean only in a well ventilated area and avoid any product containing carbon tetrachloride or other toxic materials.
- Use a professional furniture cleaning service for overall cleaning.

---

***Fabric Cleaning Codes***

The codes listed below refer to cleaning instructions recommended by the fabric manufacturing industry. Since most fabrics are hand-selected it is up to you to obtain the cleaning code for a particular fabric. If a spill occurs blot the moisture as quickly as possible. **Do not** use soap and hot water as this may set a stain. Obtain the cleaning code for the fabric as soon as possible.

**"W"** - Clean this fabric with the foam only of a water-based cleaning agent to remove the overall soil. Many household cleaning solvents are harmful to the color and life of a fabric. Cleaning only by a professional furniture cleaning service is recommended. To prevent overall soil, frequent vacuuming or light brushing to remove dust and grime is recommended.

**"S"** - Clean this fabric with pure solvents (petroleum distillate-based products such as Energine, Carbona, Renuzit, or similar products may be used) in a well ventilated room. Cleaning only by a professional furniture cleaning service is recommended.

**"S/W"** - Clean this fabric with the foam only of a water-based cleaning agent or with a pure solvent in a well ventilated room (petroleum distillate-based products such as Energine, Carbona, Renuzit, or similar products may be used). Cleaning only by a professional furniture cleaning service is recommended. To help prevent overall soiling, frequent vacuuming or light brushing to remove dust and grime is suggested.

**CAUTION: Use of water-based or detergent-based solvent cleaners may cause excessive shrinking. Water stains may become permanent and unable to be removed with solvent cleaning agents. Avoid products containing Carbon Tetrachloride as it is highly toxic. To help prevent overall soiling, frequent vacuuming or light brushing to remove dust and grime is recommended.**

"P" - The article is resistant against perchlorethene, cleaning benzine (spirit), white spirit, R-11 and R-13.

"Dry Clean Only" - Cleaning only by a professional dry cleaner or furniture cleaning service is recommended for this fabric.

"X" - Vacuum only. A non-metallic brush may be used.

**\*Machine Washing for 100% Polyester:**

"Wash Cycle" - Use synthetic setting and high water level with mild agitation. A mild soap or detergent in water not to exceed 160° F. No bleach or fabric softener.

"Drying" - Use low temperatures, a synthetic setting of 85° F to 90° F maximum should be used. Do not exceed three to five minutes time on the synthetic cycle. If washed at 160° F, the maximum temperature which can be used to dry is 140° F. Hang or fold immediately after drying.

If necessary, press as following:

- Iron on low setting (275° F) with damp cloth or steam iron using a dry press cloth.
- Grid Head press for short intervals with minimum steam. Do not lock the head.
- Flat bed press dampened drapery using cloth covering.
- Avoid prolonged contact with heat.

**Fabric Specifications**

APPLICATION	COLOR/PATTERN	CONTENTS	CODE
<b>Romanesque .65c</b>			
Sofa, Living Room Lambrequin, Chair	Hew itt Putty	67% Acrylic, 33% Polyester	W
Living Room Lambrequin, Booth Dinette, Free Standing Dinette, Living Room Pillow	M-6315 Pew ter	55% Rayon, 45% Polyester	S
Living Room Pillow , Living Room Accent	Clarity Mist	38% Acrylic, 32% Polyester, 27% Viscose, 3% Olefin	W
Bedsread, Bedroom Lambrequin, Headboard Trim	Cloe Hematite	53% Polyester, 13% Spun Viscose, 27% Rayon, 7% Spun Rayon	Dry Clean
Bedroom Lambrequin, Headboard, Bedroom Pillow	Caterina Hematite	53% Polyester, 13% Spun Viscose, 27% Rayon, 7% Spun Rayon	Dry Clean
Decorative Pillow Trim	Heirloom FRL Verde Loop Fringe	58% Polyester, 42% Polypropylene	S
Optional Leather / Vinyl Upholstery	Optima Leather Kilimanjaro	100% Polyurethane facing, Rayon backing	Optima Leather
Dash	Kilimanjaro	Vinyl	Vinyl
Vinyl	"O" Vinyl Kilimanjaro	100% Vinyl facing,100% Polyester backing	"O" Vinyl
Windshield	Johnson Cream	100% Polyester	Dry Clean
<b>Autumn Trellis .81b</b>			
Sofa, Living Room Lambrequin, Living Room Chair/ Recliner	Thin Air Havana	46% Acrylic, 45% Olefin, 9% Polyester	W
Living Room Lambrequin, Living Room Pillow , Dinette Booth, Free Standing Dinette	Villa d-Este Henna	40% Acrylic, 30% Polyester, 30% Rayon	S
Living Room Pillow , Living Room Accent	Nicoise Henna	52% Rayon, 48% Polyester	S
Bedsread, Bedroom Lambrequin	Tukka Spice	100% Cotton Sateen	Dry Clean
Bedroom Lambrequin, Bedroom Pillow , Living Room & Bedroom Sw ag	Dynasty DY Taupe	52% Cotton, 48% Rayon	S-Dry Clean
Windshield	Johnson Cream	100% Polyester	Dry Clean
Dash Vinyl	Palomino	Vinyl	Vinyl
Vinyl	"O" Vinyl Palomino	100% Vinyl facing, 100% Polyester backing	"O" Vinyl
Optional Leather / Vinyl Upholstery	Optima Leather Palomino	100% Polyurethane facing, Rayon backing	Optima Leather
<b>Espresso .80b</b>			
Sofa, Living Room Chair/Recliner	CJ-12273 DeeJay 850-05 Mushroom	79% Rayon, 21% Olefin	S
Free Standing Dinette, Booth Cushions, Living Room Pillows, Living Room Lambrequin	Reliance Bedroomow n (formerly Melanie Bedroomow n)	54% Polyester, 46% Spun Rayon	S
Free Standing Dinette, Dinette Booth, Living Room Pillows, Living Room Lambrequin	Melanie Bedroomow n	63% Spun Rayon, 37% Polyester	S
Living Room Pillow , Living Room Lambrequin	Orient Chocolate F-0132549/01200048	53% Rayon, 26% Cotton, 20% Polyester, 1 % Nylon	S
Bedsread, Bedroom Lambrequin	Eros Chocolate	100% Cotton Sateen	Dry Clean
Bedroom Lambrequin, Bedroom Pillow	Supreme Satin Chocolate	69% Rayon, 31% Acetate	Dry Clean
Living Room Sw ag, Bedroom Sw ag	Supreme Satin Acorn	69% Rayon, 31% Acetate	Dry Clean
Windshield	Johnson Cream	100% Polyester	Dry Clean
Dash Vinyl	Palomino	Vinyl	Vinyl
Vinyl	"O" Vinyl Palomino	100% Vinyl facing, 100% Polyester backing	"O" Vinyl
Optional Leather / Vinyl Upholstery	Optima Leather Palomino	100% Polyurethane facing, Rayon backing	Optima Leather
<b>Green Manor .29a carryover décor</b>			
Sofa, Living Room Lambrequin, Dinette Booth	Kingsland Forest	34% Rayon, 35% Acrylic, 31% Polyester	S
Living Room Lambrequin, Free Standing Dinette, Living Room Pillow	Trump Card Forest	38% Rayon, 31% Acrylic, 31% Polyester	S
Living Room Pillow , Living Room Accent	Double Deuce Forest	53% Acrylic, 47% Polyester	W
Living Room Chair, Bedroom Lambrequin, Bedroom Pillow , Headboard	Ribbit Pear	42% Polyester, 32% Rayon, 26% Acrylic	S
Bedsread, Bedroom Lambrequin, Headboard Trim	Lahaina Coconut	100% Cotton	S-Dry Clean
Living Room Sw ag, Bedroom Sw ag	Embassy Satin Flax	66% Rayon, 34% Acetate	Dry Clean
Windshield	Johnson Cream	100% Polyester	Dry Clean
Dash Vinyl	Milkweed	Vinyl	Vinyl

## Vinyl

Several areas of the motorhome such as items of furniture may be covered in vinyl. The care and cleaning of those area are as follows:

**Morbern Vinyl:** Vinyl requires periodic cleaning to prevent the buildup of dirt and contaminants that may permanently stain and/or reduce the life of the vinyl if not removed. The frequency of cleaning depends upon the amount of use and the environmental conditions in which the vinyl is subjected. Procedures used for cleaning are dependent upon the end-use circumstances.

**Normal Cleaning:** Most common stains can be cleaned using warm soapy water and clear water rinse. Moderate scrubbing with a medium bristle brush will help to loosen soil from the depression of embossed surfaces. For stubborn stains use the following commercially available mild detergents in accordance with the manufacturer's instructions: Mr. Clean or Fantastik. Full strength rubbing alcohol or mineral spirits may be tried cautiously as a last resort on very stubborn stains if the above suggestions do not work. Indiscriminate use of any solvent, or solvent containing cleaner, can severely damage or discolor the vinyl. Stains may become permanent if they are not removed immediately. The procedure for removal of the more severe staining agents are outlined below.

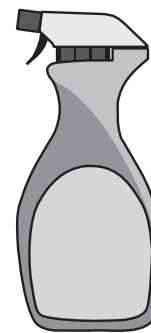

cleaner

**NOTE:** Detergents should never be used on a regular or repeated basis for normal cleaning.

**CAUTION:** Powdered cleaners containing abrasives, steel wool and industrial strength cleaners are not recommended for Morbern vinyl.

**Bird Excreta & Vomit Stains:** Sponge the area with soapy water containing a diluted bleach until the stain is removed. Rinse thoroughly with clean water.

**Urine Stains:** Sponge with soapy water containing a small amount of household ammonia. Rinse thoroughly with clean water.

**Surface Mildew:** Wash with diluted bleach and use a soft brush for stubborn growth. Rinse repeatedly with clear, cold water.

**Ballpoint Ink:** Permanent Marker Ink spots will stain the vinyl permanently. Wipe the stain immediately with rubbing alcohol in a well ventilated area to remove much of the stain.

---

**OIL-BASE PAINT: USE TURPENTINE IN A WELL VENTILATED AREA TO REMOVE ANY FRESH PAINT. DRIED PAINT MUST BE MOISTENED USING A SEMI-SOLID, GEL-TYPE STRIPPER. THE SOFTENED PAINT CAN BE GENTLY SCRAPED AWAY. RINSE WITH SOAP AND WATER.**

**CAUTION:** Lacquer solvent will cause immediate irreparable damage to the vinyl. Do not use wax on any vinyl upholstery as it will cause premature embrittlement and cracking. Dilute chlorine bleach before using. Never use full strength bleach.

**CAUTION:** Paint strippers will remove the print pattern and damage the vinyl if it comes in direct contact.

**WARNING:** If flammable solvents such as alcohol, turpentine or varsol are used for cleaning, use only small quantities while in a well-ventilated area. Exercise proper caution by notifying any persons in the area. Keep away from any ignition source. Always wear protective gloves.

**Latex Paint:** Fresh paint can be wiped off with a damp cloth. Hot soapy water will normally remove dried latex.

**Tar or Asphalt:** Remove immediately. Prolonged contact will result in a permanent stain. Use a cloth lightly dampened with mineral spirits and rub the stain gently, working from the outer edge of the stain toward the center to prevent spreading. Rinse with soap and water.

**Crayon, Mustard or Ketchup:** Sponge with mild soap and water. For stubborn stains that may have set, use a cloth soaked in diluted mild detergent with gentle rubbing. Any remaining stain should be washed with diluted bleach. Rinse repeatedly with cold water.

**Chewing Gum:** Scrape off as much gum as possible using a dull knife. Rub the gum with an ice cube to harden and make it easier to remove. In a well ventilated area, use a cloth saturated with mineral spirits and gently rub the remaining gum. Rinse thoroughly with clean water.

**Lipstick, Grease, Oil, Make-Up or Shoe Polish:** Apply a small amount of mineral spirits with a cloth. Rub gently. Be careful not to spread the stain by smearing it beyond its original source. Remove shoe polish immediately as it contains a dye which will cause permanent staining. Rinse thoroughly with clean water.

**Candy, Ice Cream, Coffee, Tea, Fruit Stains, Liquor, Wine, Tanning Lotion or Soft Drinks:** Use lukewarm water and sponge repeatedly. Any loose material should be gently scraped with a dull knife. Any soiled area that remains after drying should be gently rubbed with a cloth, dampened with a mild detergent solution. Rinse thoroughly with clean water.

**Blood or Plant Residue:** Rub out any spots with a clean cloth soaked in cool water. If stubborn spots remain use household ammonia and rinse repeatedly with a clean, wet cloth. Do not use hot water or soap suds as this will set the stain.

**TIP:** Vinyl requires periodic cleaning to maintain its appearance and to prevent the buildup of dirt and contaminants that may permanently stain or reduce the life of the vinyl if left untreated. Frequency of cleaning and procedures used depend upon the amount of use and the environmental conditions in which the vinyl is subjected. Tears or holes in the vinyl can be temporarily covered with clear “office” tape to prevent further damage. Repairs should be made by a professional upholstery shop. Commercial repair products may contain lacquers and cause the vinyl to become brittle and more difficult to repair.

---

## **Leather**

**Spots & Spills:** Absorb excess liquid immediately with a clean cloth or sponge. Use water only if necessary. Do not use a cleaning product. If water is used, clean the entire area where the spot occurred. An example would be the entire seat cushion or the entire arm. Allow to air dry. Do not dry the wet areas with hair dryers, etc.

**Stubborn Spots and Stains:** Use lukewarm water and a mild soap to work up a thin layer of suds on a piece of cheesecloth. Scrub the surface. Rinse with a piece of clean, damp cheesecloth. Allow to air dry. Do not use saddle soap, cleaning solvents, furniture polish, oils, varnish, abrasive cleaners, soaps or ammonia water.

**NOTE:** These are recommended or suggested methods of cleaning. The manufacturer is not responsible for damage incurred while cleaning. Always test the cleaning method in an inconspicuous area first before applying to the entire area.



**Care Instructions:**

- Spot clean with mild soap and water.
- Air dry or dry quickly with warm setting of a hair dryer.
- For stubborn stains, use mild solvent.
- For tougher stains, try *Fantastik*® brand spray cleaner.
- Disinfect with a **5:1 NON-CHLORINATED** (only) bleach solution.
- Dry clean using commercial dry cleaning solvents only.
- Use a mild detergent for:
  - Red Wine, Liquor - Coffee, Tea, Cola - Milk
  - Ketchup, Mustard, Mayonnaise - Steak Sauce, Soy Sauce
  - Butter, Salad Oil - Chocolate - Lipstick, Make-up, Face Cream
  - Suntan Oil - Machine Oil - Urine, Blood

**Removing ballpoint pen stains:** Wipe the stain off with ethanol (ethyl alcohol). If the stain cannot be removed with ethanol, use the following procedure. Proceed with caution when using toxic chemical.

1. Prepare bleach. Dilute household bleach (sodium hypochloride) with the same amount of water.
2. Place a piece of tissue and apply the solution prepared by step 1 (do not apply too much). Cover it with polyethylene film to prevent the solution from drying.
3. Remove the tissues occasionally to check on the condition of the stain. When the stain is almost gone, remove the tissues completely. Do not leave on for more than one hour.
4. Wash the stain with sufficient amount of water.

**If there is residue of bleach, polyurethane resin and back cloth will deteriorate.**

**Neutralize it by the following method:**

- Place a piece of tissue, as in step 2, and apply hydrogen peroxide solution (15%).
- Leave the solution on for approximately 30 minutes, then remove the tissue.
- Completely remove the residue of hydrogen peroxide on the Ultra-leather with water.

Sodium hypochloride is the only chemical that will remove ballpoint pen stains. However, this chemical may cause polyurethane to yellow or the back cloth to deteriorate. It is recommended to remove ballpoint pen stains as early as possible with ethanol.

**For more information, please call:  
Ultrafabrics, LLC  
Customer Service: 1-877-309-6648**

## FLOORS - Carpet Cleaning

### Spot Removal Procedures:

- Act quickly when anything is dropped or spilled. Remove spots before they dry.
- Blot liquids with a clean, white absorbent cloth or paper towel.
- For semi-solids, scoop up with a rounded spoon.
- For solids, break up and vacuum out as much as possible.
- Pretest the spot removal agent in an inconspicuous area to make certain it will not damage the carpet dyes.
- Apply a small amount of the cleaning solution recommended for the particular spot. Do not scrub. Work from the edges of the spot to the center. Blot thoroughly. Repeat until spot is removed.
- Follow steps on the Carpet Spot Removal Guide.
- After each application, absorb as much as possible before proceeding to the next step.
- Absorb remaining moisture with layers of white paper towels, weighted down with a non-staining glass or ceramic object.
- When completely dry, vacuum or brush the pile to restore texture.
- If the spot is not completely removed, contact a professional carpet cleaner.

Use the solution specified in order from 1-8 until stain is removed.	A	B	C	D	E	F	G	H	I
	DRY CLEANING FLUID	NAIL POLISH REMOVER	DETERGENT SOLUTION	WARM WATER	VINEGAR SOLUTION	AMMONIA SOLUTION	STAIN REMOVAL KIT	CALL PROFESSIONAL	PERMANENT CHANGE
<b>SPOTS</b>									
Acid				2		1		3	*
Acne Medication		1		2	5	4	3	6	*
Alcoholic Beverage			1	4	3	2			*
Ammonia				2	1				*
Bleach		1	2					3	*
Blood		1	3		2	4			
Candle Wax	1					2			
Cement & Glue	2	1	3		5	4	6		*
Chalk		1	2						
Charcoal		1	2						
Chewing Gum	1								
Coffee			1	3	2		4	5	*
Cosmetics		2	1	3	6	5	4	7	*
Crayon	1		2	3					
Drain/Toilet Cleaner			2	1	3			4	*
Dye	1		2		4	3	5	6	*
Food			1	4	3	2	5	6	*
Fungicides, Insecticides, Pesticides	1		2	5	4	3	6	*	
Furniture Polish (Water Based)			1	4	3	2	5	6	*
Furniture Polish (Solvent Based)	2	1	3	6	5	4	7	8	*
Furniture Stain	2	1	3	6	5	4	7	8	*
Graphite		1	2						
Grease	1	2	3				4	5	*
Ink	2	1	3	6	5	4	7	8	*
Iodine	1		2	5	4	3	6	7	*
Lipstick	2	1	3	6	5	4	7	8	*
Medicine	2	1	3	6	5	4	7	8	*
Merthiolate			1	4	3	2	5	6	*
Nail Polish	2	1	3				4	5	*
Oil	1		2	4		3		5	*
Paint	2	1	3				4	5	*
Plant Food			1	4	3	2	5	6	*
Rust			2	3	1		4	5	*
Shoe Polish	2	1	3	5		4	6	7	*
Soft Drinks			1	4	3	2	5	6	*
Soot	1		2	3				4	*
Tar	1						2	3	*
Toothpaste			1						
Urine			1		2		3	4	*
Vomit			1	4	3	2	5	6	*

\* While recommended cleaning agents are effective, some stains may become permanent.

**Cleaning Solutions:**

- A. Dry Cleaning Fluid:** A nonflammable spot removal liquid, available in grocery and hardware stores.
- B. Nail Polish Remover:** Any acetate, which often has a banana fragrance. Do not use if it contains acetone.
- C. Detergent Solution:** Mix two cups of cold water and 1/8 teaspoon mild liquid detergent (no lanolin, non-bleach).
- D. Warm Water:** Lukewarm tap water.
- E. Vinegar Solution:** One cup white vinegar to one cup water.
- F. Ammonia Solution:** One tablespoon household ammonia to one cup water.
- G. Kit-Spot Removal:** Available from retail carpet stores or professional cleaners.
- H. Call Professional:** Additional suggestions, special cleaning chemicals or the ability to patch the area might be available.
- I. Permanent Change:** Due to the nature of the stain, there may be color loss. The carpet has been permanently dyed or the carpet yarns have been permanently damaged.

**NOTE: While the recommended cleaning agents have proven to be effective, some stains may become permanent.**

## **Tile Floors**

Tile floors vary in porosity and surface irregularities. This can make it difficult to protect and maintain. Regular maintenance is important to keep the tile in the motorhome looking showroom new. Once the slide-out has been extended, keep the tile floor clean to prevent dirt from scratching the tiles prior to retracting the slide-out.

**NOTE: Tile is ceramic and will chip and break easily. Avoid dropping heavy or sharp objects on the tile.**

**Cleaning Tile:** Use a damp sponge mop or a cloth to clean tile and maintain its luster. If moderate staining occurs, cleaning with a window cleaner such as Windex should do the job. A mild solution of hot water and all-purpose cleaner for tile floors, walls and countertops can also be used. Rinse well with clear water and dry with a soft cloth to prevent streaking. Avoid cleaning tile with soap. Soap forms a film to dull the luster. Soap also promotes the growth of mildew and bacteria. Do not use powdered cleaners on unglazed tile floors. Undissolved powder will dull the surface. Grout sealers are available that protect the porous surfaces. If a sealer is used, follow the sealant manufacturer guideline for application. Never use sealers on unglazed tile. With the exception of terra cotta, which may be oiled or waxed, tile does not need to be polished or buffed maintain its finish.

**Grout:** The grout used is a two part concrete mix. It is normal for this type of grout to develop surface cracks over time. In motorhome application, due to the constant flexing of the flooring, this process may accelerate. If the grout requires cleaning, scrub with a plastic brush. Do not use steel wool as small particles may remain and produce unsightly stains.

**NOTE: Before using any solution to clean the tile, check the manufacturer's warning label to ensure the safety of the product. If there is any doubt, apply several test patches of the solution in an inconspicuous place to determine the product's suitability.**

---

## **Laminate Floors (Optional)**

Laminate flooring used in the motorhome provides style, durability and ease of maintenance. This high-pressure laminated flooring is designed to be incorporated as a floating floor.

Laminate flooring is constructed of three main material components. The surface, similar to many countertops, contains aluminum oxide particles to form an extremely hard, durable outer layer. The carrier, or core layer, is constructed from high density fiberboard. A tongue and groove design provides a tighter bond. The backer or bottom layer is also made of laminate for strength.

**Cleaning and Maintenance:** For everyday cleaning, vacuum the floor to remove dirt and debris. It is recommended to occasionally mop the floor using a cotton string mop and a minimal amount of water. Use a mixture of soap-free household cleaner (either vinegar or ammonia work well) and water for a more thorough cleaning.

- Wipe away stains with a damp cloth.
- Stains caused by inks or paints may require a cloth moistened with acetone (nail polish remover).
- Stains caused by gum or tar should be allowed to harden completely, then gently scraped away.
- Felt protectors on the bottom of furniture and floor mats can preserve the beauty and appearance of the flooring.

**CAUTION: Abrasive cleaners and scouring pads can scratch and damage the flooring. Never wax, sand or apply lacquer to laminate flooring.**

**NOTE: Any unusual or unique problems concerning the laminate flooring can be addressed as follows:**

**For more information, please call:  
Wilsonart  
(800) 433-3222**

---

## **SHOWER**

Showers are susceptible to soap build up. Showers should be cleaned weekly to prevent burdensome clean-up. Using the same solution used to clean tile floors will be sufficient for the shower. However, to control mildew growth spray the shower with household chlorine bleach and allow it to stand for five minutes. Clean the glass shower doors with window cleaner on a weekly basis to maintain the shine. If water spots cannot be removed from the glass, rub lightly with the flat edge of a razor blade to remove deposits.

To prevent excessive moisture and a continual growth of mildew, use the shower only with adequate ventilation. The sealant in a regularly used shower should be replaced once a year. To replace sealant, remove the old sealant using a sharp non-metallic instrument. Apply a new sealant, which can be found at most recreational vehicle supply stores.

## CEILING

The ceiling of the motorhome can be a variety of materials or fabrics.

**Vinyl:** The following steps are to be performed in sequence for recommended cleaning methods for the Vinyl Ceiling material. Each subsequent step is to be used if the previous step was not successful.

1. Wipe the soiled area with warm water, a mild detergent soap and a soft cotton cloth.
2. Spray soiled area with a general household cleaner, such as 409 or diluted solution of a liquid citrus-based cleaner. Follow the citrus-based cleaners recommendations for diluting. Wipe with warm water using a soft cotton cloth.
3. Dab soiled area with solution of 50% Isopropyl Alcohol and 50% warm water using a soft cotton cloth.
4. Dab soiled area with 100% Isopropyl Alcohol using a soft cotton cloth.

After each process, clean the area with warm water.

**WARNING: When using an alcohol solution avoid open flames or hot lighting.**

**NOTE: Use care not to puncture the padded vinyl.**

**Hardwood Vinyl and Decorated Paneling:** Hardwood vinyl and decorated paneling are sensitive and demanding materials. Certain cleaning agents will affect the surface on both printed and unprinted vinyl. Use only a mild, non-abrasive detergent and warm water with a soft cloth or sponge for cleaning to protect the material.

Under no circumstance should bleach, alcohol, oil-based spray cleaners or cleaning agents with solvents, citrus oil or harsh chemicals be used. Other liquid spray cleaners may also cause damage to the material.

---

**WALL COVERINGS**

Time is very important when removing substance from wall coverings that are solvent based or contain color. Do not use abrasive cleaners containing chlorine bleach or solvents. *Fidelity* and *Jolie* brands are recommended. Always begin with a mild detergent or soap and warm water. To remove normal dirt clean with a soft sponge. Rinse and wipe dry.

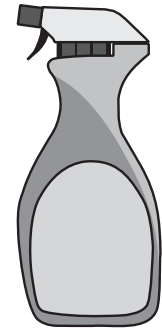

cleaner

**Care for the Tower Wall Covering:** Remove ordinary stains with mild soap and warm water. Sponge on. Rinse well and dry with a soft cloth. **For special cleaning problems:** To remove ball point pen, blood, lipstick, etc., use a sponge or soft bristle brush and *Formula 409*, *Fantastik* or a similar product. Rinse well and dry. Finish cleaning by applying full strength isopropyl alcohol with a sponge or soft brush. Rinse well and dry.

**Care for the Satinesque Wall Covering:** Stains should be removed as quickly as possible to minimize reaction between the staining agent and wall covering. Time is very important when removing substances that are solvent based or contain color. Examples: nail polish, oil, shampoo, lacquer, enamel, paint, ink and lipstick.

Always begin cleaning with a mild detergent such as soap. If necessary, move to a stronger cleaner such as household bleach, liquid household cleaners or rubbing alcohol. Before using one of the stronger cleaners, test the cleaning agent on a small inconspicuous portion of the wallcovering to make sure that the cleaner does not affect the color or gloss of the wall covering.

#### **Stain Removal Procedures for Specific Stain Types:**

**Normal Dirt:** Remove normal dirt using a mild soap or detergent and warm water. Allow it to soak for a few minutes then rub briskly with a cloth or sponge.

**Nail Polish, Shellac or Lacquer:** Remove liquid using a dry cloth. Use care not to spread the stain. Quickly clean the remaining stain with rubbing alcohol. Rinse with clean water.

**Ink:** Remove immediately by wiping with a cloth dampened in rubbing alcohol. Rinse with clean water.

**Chewing Gum:** Rub with an ice cube to cool and harden. Gently pull off the bulk of the gum. Remove any remaining gum with rubbing alcohol.

**Pencil:** Erase as much of the pencil mark as possible. Wipe any remaining marks with rubbing alcohol.

**Blood, Feces or Urine:** Remove these staining substances as quickly as possible. Wash the stained area with a strong soap. If the stain does not disappear, rinse the soapy area thoroughly with clean water. Mix a solution of 50% water and 50% household bleach. Clean the stained area with the bleach solution. Rinse with clean water.

---

---

## WOOD CARE

Wood should be treated the same as a piece of fine furniture. Care and cleaning of the wood surface is essential in maintaining the natural beauty of wood. Keep in mind that wood finishes can vary widely. Test a new cleaning solution in an inconspicuous area to check for possible damage.

The care and cleaning of the solid wood surfaces and the wood products used in the motorhome depends on individual choices and preferences. Numerous waxes, polishes and finishing products are available for use. Always follow the manufacture label and instructions. The solid wood surfaces should be cleaned weekly. Dust regularly with a soft, lint-free cloth. Dampen the cloth slightly with water. Wipe one small area at a time and dry immediately.

For stubborn stains, use a clean cloth dampened with a solution of mild, non-alkaline soap (like dishwashing liquid) and water. Dry thoroughly using a soft cloth. Buff lightly, following the direction of the grain. Never use abrasive cleaners, scouring pads or powdered cleansers.

Excessive dampness, dryness, heat, or cold can damage solid wood finishes. Sunlight can change the color or age the wood. Never allow moisture or spills to stand, always blot dry immediately. Solvents, alcohol, nail polish and polish removers, as well as harsh cleaners should not be used on finished wood surfaces.

Minor damage to solid wood surfaces can be repaired quickly and effectively with a bit of hard work, some careful attention to details, and most importantly, the right materials. However, any wood repair or finishing job is best left for a professionally trained individual.

**NOTE: It is important to inform the service technician of any products used for the care and cleaning in the event of wood repairs.**

**Sanding and Sandpaper:** The following table is a general guide to the proper uses, although this may vary from wood type to type. The key to sanding is using the right sandpaper for the repair that is needed. Always sand with the grain.

<b>GRIT</b>	<b>Grade</b>	<b>Usage</b>
80-120	Medium	Smoothing the surface, removing small marks.
150-180	Fine	Final sanding prior to finishing.
220-240	Very Fine	Sanding between coats of sealing.
280-320	Extra Fine	Removing dust spots or mark between finish coats.
360-600	Super Fine	Fine sand of the finish to remove luster or surface blemishes.

**Steel Wool:** Abrasive material composed of long steel fibers of varying degrees of fineness that are matted together. The coarser grades are used to remove paint and other finishes; the finer grades for polishing or smoothing a finished surface.

**Nail Holes and Small Cracks:** Fill nail holes and small cracks with wood putty or dough for unstained woods prior to any sanding. Stained finishes require filling holes and cracks after the stain has been applied. Putty should match the stain closely in color.

**NOTE: A little sawdust and wood glue can be used to make putty for end grains.**



---

**Fixing scratches in stained woodwork:** "Quick and simple" rarely describes repairs to stained wood finishes. However, a few tricks can be tried. When scratches appear lighter than the surrounding dark-stained woodwork, it usually means either that the scratch goes through the stain into the wood or that the varnish is flaking off.

**Dents:** Dents are the results of wood fibers being crushed and compressed. Dents can be raised back to original level by steam. To raise a dent, place a damp cloth over the dent and hold a medium-hot iron on it. The steam will cause the wood fibers to swell back into place. It may be necessary to repeat this process until the dented area is level with the surface. Allow the area to dry.

**Restoring the clear finish:** Check the scratches carefully. If flaking varnish is visible with dark-stained wood underneath, only the clear finish may need to be restored. Rub the loose varnish with fine steel wool or fine synthetic steel wool until you have removed the flaking varnish and slightly roughened a small area of the finish surrounding the scratch. With the tip of rag, a small brush, or even a cotton swab, apply a thin coat of a wipe-on finish. Apply finish to the damaged area only. Several coats may be needed to hide the scratch.

**Re-staining the wood:** If bare wood is visible at the bottom of the scratch, the wood will need to be re-stained. To remove damaged varnish, lightly roughen a small area around the scratch with sandpaper, steel wool or synthetic steel wool. Find a stain that is a shade lighter than the wood finish. Stain the bare wood with a very small amount of stain on a rag, brush or cotton swab. If the color is too light, apply several coats. Rub away excess stain with a dry rag. If the wood becomes too dark, use a rag moistened in mineral sprits to lighten the wood. Select a lighter color stain and continue.

Several companies have simplified this repair process by putting oil-based wood stain into marker-like containers. Just rub the stain marker on the scratch. Start with a stain color that is lighter than the original finish, because torn and scratched wood fibers will absorb stain and darken quickly. A second coat can always be applied if the color of the first coat is too light. Once the color is blended, patch the clear finish as described above and apply a wipe-on finish.

**Scratches and Nicks:** Several professional woodworkers use similar procedures and tricks when it comes to scratches and nicks, most of which can be easily repaired. Always test an inconspicuous area of the wood prior to repairs to ensure no damages to the finish.

Light scratches will often disappear when carefully rubbed with furniture polish or paste wax. Deeper scratches can be hidden by carefully rubbing with a piece of oily nutmeat such as Brazil nut, black walnut or pecan. Be careful to rub the nutmeat directly into the scratch to avoid darkening of the surrounding wood. Color the scratch with brown coloring crayon or liquid shoe dye (especially good on walnut).

Staining the scratch with iodine:

Mahogany - Use new iodine.

Brown or Cherry Mahogany - Use iodine that has turned dark brown.

Maple -Dilute one part iodine with one part denatured alcohol.

Commercial scratch removers, or stick wax to match the wood finish, can also be used. After the scratch has been hidden, polish or wax the entire area. Deep scratches should be repaired and finished by a professional.

## COUNTERTOPS - SOLID SURFACE

The Solid Surface was created for a lifetime of easy care. Just follow the simple guidelines listed here to keep countertop surface looking nice.

**Routine Care:** The motorhome countertops are finished with one type of finish: matte/satin. All solid surface sinks and bowls have a matte/satin finish. Soapy water or ammonia-based cleaners will remove most dirt and stains from all tops and bowls. However, slightly different techniques must be used to remove different stains. Follow the recommendations below.

**Cleaning the Countertops:**

- Most dirt and stains: Use soapy water or ammonia-based cleaner.
- Water marks: Wipe with damp cloth and towel dry.
- Difficult stains: Use soft scrub and a Grey *Scotchbrite* Pad.
- Disinfecting: Occasionally wipe surface with diluted household bleach (one part water and one part bleach).

**Cleaning the Solid Surfaces Sink:** Occasionally clean by using *Soft Scrub Liquid Cleanser* and a Grey *Scotchbrite* pad. Scrub the sink, rinse and towel dry. Do this as often as necessary.

**Removing Cuts and Scratches:** Because the beauty of the surface goes all the way through the Solid Surface, countertops are completely renewable. Use the following instructions to remove minor cuts and scratches.

- Sand with 180 grit and then 320 grit sandpaper until the scratch is gone.
- Restore the finish using a Grey *Scotchbrite* pad. Never sand hard in one small area. Feather out lightly to blend restoration.

**Preventing Heat Damage:** The Solid Surface withstands heat better than ordinary surface materials; however, hot pans and some heat-generating appliances, such as frying pans or crockpots, can damage the surface. To prevent heat damage always use a hot pad or a trivet with rubber feet to protect the surface. In most cases the surface can be repaired if it is accidentally damaged.

**Other Important Tips:** Avoid using strong chemicals on the Solid Surface such as paint removers or oven cleaners. If these chemicals come in contact with the Solid Surface, quickly wash with water. Avoid contact with nail polish or nail polish remover. If contact is made, quickly wash with water.

**NOTE: Do not cut directly on the solid surface. Always run cold water into the Solid Surface sink when pouring boiling water into the sink.**

**Laminate**

Clean laminate countertops with a damp cloth or sponge. Use a spray cleaner to remove stubborn stains. Avoid using harsh abrasives, scouring powders, peroxides or bleaches as these products may dull or damage the surface. Avoid contact with dyes, bleaches, and indelible inks on food packages. Do not use laminated countertops as a cutting board. Laminated countertops are resistant to minor heat; however, hot pans, irons, and lighted cigarettes will damage the surface. Use hot pads under pans taken directly from the stovetop.

---

**Stainless Steel Surface**

Clean stainless steel once a week. Always apply stainless steel cleaner/polish with a nonabrasive cloth or sponge, working with, not across, the grain. Do not use steel wool, wire brushes or abrasive sponge pads. Cleaners containing chloride are not recommended. If used, rinse surface immediately to prevent corrosion. Allowing water to evaporate will form water deposits. To avoid this, it is important to use a dabbing action to dry, not an abrasive or rubbing action. Cleaning with a damp sponge and drying should keep the surface looking beautiful.

---

**WINDOWS**

**Water Spots:** Any glass will develop water spots if not cleaned properly. A spotting effect is magnified when the glass has a reflective finish. Use a squeegee immediately after washing to reduce water spotting. To remove stubborn water stains from reflective glass we recommend *Cerium Oxide Polishing Compound*, made by C.R. Lawrence, available at most glass shops.

---

**Condensation**

Condensation is a natural phenomenon. The amount of condensation will vary with climate conditions, particularly in relative humidity. Condensation occurs from water vapor present in the air. Each of us add more vapors by breathing, bathing, cooking, etc. Water vapor collects wherever there is available air space. When the temperature reaches the dew point the water vapor in the air condenses and changes to liquid form.

**Controlling Moisture Condensation:** Reduce or eliminate interior moisture condensation during cold weather by using the following steps:

- Partially open the roof vents and windows so that outside air can circulate into the interior. Increase the ventilation when large numbers of people are in the motorhome. Even in raining or snowing conditions the air outside will be far drier than the interior air.
- Install a dehumidifier. Continuous use of a dehumidifier is effective in removing excess moisture from the interior air. Using a dehumidifier is not a cure-all, however, it will reduce the amount of outside air needed for ventilation.
- Run the range vent fan when cooking and the bath vent fan (or open the bath vent) when bathing, to reduce water vapor. Avoid excessive boiling or use of hot water as it produces steam.
- Do not heat the motorhome interior with the range or oven. Heating with the range or oven increases the risk of toxic fumes and allows oxygen depletion. Also, open flames add moisture to the interior air increasing condensation.
- In very cold weather leave the cabinet and closet doors partially open. The air flow will warm and ventilate the interior of the storage compartments and the exterior wall surface, reducing or eliminating condensation and preventing the possibility of ice formations.

---

## **WINDOW TREATMENTS - *Mini-Blinds***

**Dusting:** Regular dusting maintains the appearance of most blinds. Keep the aluminum blind looking its best by periodically wiping them with a soft cloth or a dusting mitt. By tilting the slats down, but not quite closed, you'll be able to clean most of the top surface of each slat. Blinds may be cleaned while hanging in place using this method.

**Vacuuming:** For deeper cleaning, vacuum gently with brush attachment of any vacuum cleaner.

**Compressed Air or Hair Dryer (non-heat setting):** Blow dust off each slat. Dust will be air-borne using this method so ventilate the motorhome.

**Spot-Cleaning:** Spot-clean shades and blinds using a soft cloth or a moistened sponge with lukewarm water. Add mild detergent, if needed. Blot gently to avoid creasing. In a dusty environment, the blinds may need to be cleaned regularly using a sponge or dampened soft cloth. Use warm (not hot) water and a mild detergent. The mild detergent cannot contain abrasives. Rinse the blinds using a clean cloth and water to prevent water spots. Place a towel directly under the blinds to absorb any water that might drip down.

**Ultrasonic cleaning:** Professional ultrasonic cleaning may be preferred.

**Tub cleaning:**

1. Immerse entire shade assembly in lukewarm water with mild detergent. Wash for several minutes by gently moving liquid around with your fingers.
2. Rinse with clear water.
3. Close shade before removing from rinse water.
4. Hold rails and tilt the shade to allow excess water to drain off.
5. Re-install damp shade into window opening. Place a towel directly under the blinds to absorb any water that might drip down.
6. Lower shade all the way to allow it to dry completely.

***Day/Night Shades (Optional)***

The Day/Night shades are made of polyester blended material. Use the following guidelines to care and maintain the Day/Night shades:

- Leave Day/Night shades in the **UP** position when not in use to help shades hold shape.
- String tension for the shades should be equal. The tension can be adjusted if the shades will not remain up.

**Dusting:** Vacuum with a brush attachment, or use a dusting tool, on a regular basis.

**Cleaning:** A dry foam cleaner may be used for soil and dirt removal. Follow all directions on the container or a cleaning solution of ¼ ounce clear liquid soap to 8 ounces water.

**NOTE: Do not use colored liquid soap as a stain may appear when fabric dries.**

**MOLD & MILDEW**

**What is Mold?** Mold is a plant in the Fungi group that occurs naturally in the environment, and is necessary for the natural decomposition of plants and other organic material. Mold spreads by microscopic spores borne on the wind, and is found everywhere life can be supported. Because mold spores are present in all types of environments, motorhome construction cannot be designed to exclude mold spores. Mold can grow in the motorhome. Most people are familiar with mold growth in the form of bread mold, and mold that may grow on bathroom tile. As old spores grow, they can leave a musty odor, discolored fabric, and stained surfaces, causing considerable damage.

**What Does Mold Need to Grow?** Being a plant, mold will need a food source in order to grow. Mold can use a variety of organic materials such as fabric, carpet, wallpaper, or even building materials, such as wood and insulation, to name a few. Grease films contain many nutrients for mold spores to grow when moisture and temperatures are right. Soil on dirty items such as fabrics and furniture may supply enough nutrients for mold to grow. Many of the synthetic fabrics such as acetate, polyester, acrylic and nylon are mildew resistant. However, soil on these fabrics may supply the nutrients to start mold growth.

Mold growth requires a temperate climate. The best growth occurs at temperatures between 40° F and 100° F. Finally, mold growth requires moisture. Moisture is a mold growth factor that can be controlled. By minimizing moisture inside the motorhome, mold growth can be reduced or eliminated.

Moisture in a motorhome can have many causes. Spills, leaks, overflows, condensation, and high humidity, to name a few. Good housekeeping and regular maintenance are essential in the effort to prevent or eliminate mold growth. If moisture is allowed to remain on a growth medium, mold can develop within 24 to 48 hours.

**Consequences of Mold:** All mold is not necessarily harmful, but certain strains of mold have been shown to cause, in susceptible persons, allergic reactions, including skin irritation, watery eyes, runny nose, coughing, sneezing, congestion, sore throat and headache. Individuals with suppressed immune systems may risk infections. Some experts contend that mold causes serious symptoms and disease which may even be life threatening. However, experts disagree about the level of mold exposure that may cause health problems, and about the exact nature and extent of the health problems that may be caused by mold. Moreover, the Center for Disease Control states that a casual link between the presence of toxic mold and serious health conditions has not been proven.

Standards or threshold limit values for concentration of mold or mold spores have not been set. Currently, there are no EPA regulations or standards for airborne mold contaminants. There is simply no practical way to eliminate all mold and mold spores in the indoor environment. For example, studies have shown that ozone cleaners are not effective at killing airborne mold or surface mold contamination.

**Controlling Mold Growth:** The owner can, and should, reduce or eliminate the occurrence of mold growth in the motorhome; thereby, minimizing any possible adverse effects that may be caused by mold. Taking the following steps can help reduce or eliminate mold growth in the motorhome.

1. Check for signs of mold prior to bringing items in the motorhome. Potted plants (roots and soil), furnishings, stored clothing and bedding material, as well as many other household goods, may already contain mold growth.
2. Regular vacuuming and cleaning will help reduce mold levels. Mild bleach solutions and most tile cleaners are effective in eliminating or preventing mold growth.
3. Indoor humidity can be reduced by 30-60% when venting clothes dryers to the outdoors. Ventilate the kitchen and bathroom by opening the windows, using exhaust fans, or a combination of both. Operating the air conditioning will remove excess moisture in the air, and help facilitate evaporation of water from wet surfaces.
4. Promptly clean up spills, condensation and other sources of moisture. Thoroughly dry any wet surfaces or material. Do not let water pool or stand in the motorhome. Promptly replace any materials that cannot be thoroughly dried.
5. **Inspect** for leaks on a regular basis. Look for discolorations or wet spots. Repair leaks promptly. Inspect condensation pans (refrigerators and air conditions) for mold growth. Take notice of musty odors, and any visible signs of mold.
6. Should mold develop, thoroughly clean the affected area with a mild solution of bleach. First, test to see if the affected material or surface is color safe. Should the mold growth be severe, call on the services of a qualified professional cleaner.
7. If materials with mold on them cannot be cleaned, they should be removed and properly disposed.



Whether or not a motorhome owner experiences mold growth depends largely on how the motorhome is managed and maintained. As a manufacturer, our responsibility is limited to things that we can control. As explained in the written warranty, we will repair or replace defects in the construction (defects defined as a failure to comply with reasonable standards of motorhome construction) for the Limited Warranty coverage period provided. **THE MANUFACTURER WILL NOT BE RESPONSIBLE FOR ANY DAMAGES CAUSED BY MOLD THAT MAY BE THE CONSEQUENCE OF OR ASSOCIATED WITH DEFECTS IN THE CONSTRUCTION.**

---

## PEST CONTROL

Pests can come in all sizes and shapes, from insects to mammal. Regardless of the area one lives in or travels to, it is safe in stating there will be pests waiting. These pests are not only annoying; they can pose health risk and create serious damage to the motorhome. There are a number of host-transmitted diseases that can be carried by a pest.

- Common pests include insects such as ants, cockroaches, termites, flies, pantry pests and wasps as well as wildlife such as rodents, raccoons, bats, birds and snakes. It is important to remember, pests are the same as humans in the fact they need food, water and a place to live. Eliminating any one of those elements will help significantly in controlling the pest.

To control pest infestation, eliminate those factors that attract pests, and take immediate steps to remove a pest as soon as presence is detected. There are a number of steps that can be taken to help in controlling pests:

- Reduce clutter inside the motorhome and storage bays. All storage items, particularly food (including pet food), should be kept in tightly sealed containers. Seal all cracks and holes, and insure that window, door and vent screens are securely in place.
- Routinely clean the motorhome, including storage bays. Wipe down the water bay. Promptly remove all crumbs from areas where food is regularly prepared and eaten. Garbage should be placed in a sealed container and removed to an outside receptacle daily. Only put out pet food that will be immediately eaten.
- Keep foods such as flour, cereal, spaghetti and pet food in re-sealable containers with tight lids.
- Sweep and vacuum often (especially in eating areas) to help eliminate food sources for some pests.
- Seal cracks, crevices, and other gaps especially around doors and windows. Make sure all windows and doors are screened and fit the screens snugly in the frames.
- Many pests need moisture to successfully live and reproduce. Limit access to water or moisture sources by sealing cracks and leaks in pipes and faucets. Reduce moisture in the motorhome by controlling condensation, immediately wiping up spills and promptly repairing leaks. Be extra alert around areas that attract rodents and insects, including the sewer hose, fresh water hose, bay doors and items that may be leaning against the outside of the motorhome, such as fishing poles and golf clubs.

- When the motorhome is stored outdoors, clear the surrounding area of all rodent friendly hiding places - shrubs, trees and clutter. Completely seal the underside of the motorhome. Wire mesh will work well to prevent points of entry, but beware of blocking necessary air vents. Prior to operating the motorhome after storage, remove all insect and animal nests that may have developed around vents, engine compartments, and the exhaust pipe and in the wheel wells.

**Rodents:** Rodents may chew through wires or build nests in components of the motorhome. Signs of rodent infestation include droppings, shredded material or chewed furniture fabrics and vinyl. Rodents like to build nests with wire insulation, and are commonly attracted to the outside coating of 110 wiring more than 12-Volt wiring.

**NOTE: Although the back cap on most motorhomes is well sealed, rodents are capable of chewing through the foam insulation and that area should be routinely inspected.**

If there are signs of rodent infestation around the motorhome, place traps or poisons in suspected areas. Keep the traps and poisons safely away from pets and children. Cheese is not the best bait for a rodent trap. Use peanut butter or chocolate in small amounts. Place the bait on the trigger of the trap to induce the rodent to climb onto the trigger to reach the bait. Rodents do not limit invasion to unused vehicles.

**Insects:** Eliminate insects the moment a sign of infestation is spotted. If you are unable to identify the type of insect, purchase some sticky traps from the hardware store and place the tape where you have seen the insects. Once caught, seek assistance in identifying the insect and determining what will be required to remove the infestation.

Regularly inspect the exterior of the motorhome for signs of a budding wasp nest, and promptly destroy small nests before they become too large.

Spiders can be in any structure. Since they are predators and feed on living prey, this would indicate other smaller pests may be found. Immediately remove spider webs. Some types of spiders like to nest on top of the diesel tank and around the diesel hoses. Dispense of spiders using a vacuum. Use care to capture the spider and egg sacs. Throw the vacuum bag away in a sealed bag.

Fruit flies invade the motorhome by attaching themselves to fresh fruits and vegetables. Determine what food items are generating the flies and discard that item in an outdoor trash receptacle. Any remaining fruit flies can be eliminated with a homemade trap. Pour a few ounces of vinegar into a cup and cover the cup with plastic wrap. Secure the wrap with tape or a rubber band and poke a ¼" hole in the plastic. Place the trap in the area where fruit flies are present.

Ants live in colonies. Only a fraction of the ant colony will leave to seek food. Spraying pesticides will only kill the ants that are away from the colony. To eliminate all ants, the colony must be destroyed. Keep ants away from the sewer hose by spraying the hose ends with a soap and water solution.

Fleas can be removed by properly treating pets with a veterinarian-approved treatment and a thorough cleaning of the motorhome. Vacuum vinyl areas and tile floors to remove dust, flea larva and flea eggs. Follow by thoroughly washing those areas with soap and water. Carpets must be vacuumed and treated with a residual flea control product labeled safe for indoor carpet and furniture use.



Perform the cleaning treatment daily for three days to insure that all fleas have encountered the treatment.

Flying outdoor insects are attracted to bright light. Yellow porch light covers on the motorhome work to discourage insect invasion. During nighttime hours insects will be attracted to docking lights, or other bright exterior lighting.

If the presence of moths is detected inside of the motorhome, usually by holes appearing in material, clean the affected clothing and all other items stored in the same area. Follow by completely cleaning the closet, dresser or storage area. If cracks are detected, seal the cracks and treat the area with a properly labeled indoor pest control product.

Even birds can be considered pests, particularly when the motorhome is parked in the flight path of a flock. Bird droppings are hard to remove and will leave stains. Prevent permanent staining to the motorhome roof by regularly cleaning the surface to remove all bird droppings.

**Damage from Pests:** Lizards can be captured using glue traps. To remove the lizard from the trap, dissolve the glue with vegetable oil and then release the lizard outside and well away from the motorhome. A scorpion will glow blue-green in UV light. If you suspect the presence of scorpions in the motorhome, investigate with an UV black light during the nighttime hours.

**What are the best sources of information about common household pests?** The Internet is a great place to find information about common pests, however, the information is not always correct. The National Pest Management Association website can be useful resource about common pest. Another good source for information are colleges and universities with entomology departments (entomology is the study of insects).

Electronic pest control devices can be costly and most likely will not work on all types of rodents and insects. When calling on the services of a professional to combat pest infestation, call a reputable business that is licensed in handling pesticides. Check references. Explain that you are seeking assistance for a motorhome, as treatments may differ from standard household jobs.

If you do suspect a pest problem in the motorhome, consider professional pest control help. The following guidelines can be used for selecting a pest control service.

- A good place to start is to inquire as to who has used pest control services. Inquire about the type of pest problem encountered and how satisfied they were with the service.
- Membership in the national, state or local pest control associations is a good indicator that the company has access to modern technical information and is committed to further education.
- Reach a complete understanding with the company before work starts; find out what the pest is, how the problem will be treated, how long the period of treatment will be, and what results can be expected.
- Be sure to understand what is guaranteed and what is not.

## **STORAGE - Short Term**

Short term storage is defined as storing the motorhome for a period of thirty days or less. Properly preparing the motorhome during periods of short term storage will make bringing the motorhome out of storage a much easier process. Winterize the plumbing system if the motorhome is stored in winter months or if stored when temperatures are below 32° F.

### **Checklist-Short Term Storage:**

- If applicable, retract the slide room(s). Do not store the motorhome with slide room(s) extended.
- Shut off all appliances. Close the primary LP-Gas valve.
- Remove all articles from refrigerator/freezer and clean thoroughly. Prop doors open to prevent mildew.
- Holding tanks should be drained and fresh water system winterized, with potable antifreeze or winterize the plumbing system using air pressure.
- Retract and secure all awnings.
- Turn **OFF** the battery cut-off switch.
- Batteries should be stored fully charged. Batteries stored in a discharged state will readily freeze.
- If possible, park the motorhome so that the batteries are accessible for charging or changing without having to move the motorhome.
- If available, leave the motorhome hooked to shore power. Leave the main battery disconnect switch **ON**.
- Careful placement of a small heat source in the interior will help control moisture. Desiccate filter systems help remove interior moisture.
- If AC power is not available turn the main battery disconnect switches **OFF**.
- If possible, store the motorhome inside a storage building.
- If stored outside, inspect all seams and seals for possible leakage.
- Store the motorhome with a full fuel tank to minimize moisture condensing at top of fuel tank.
- Vents and windows should be closed to prevent wind driven rain entrance.
- Tires should be stored at maximum inflation pressure.
- A full interior inspection for water leaks should be made bi-monthly, inspecting behind all cabinet doors and drawers.
- Start and run the generator at least 1/2 hour per month.

---

## **Long Term**

Long term storage of the motorhome can be defined as leaving a motorhome unattended for a period of thirty days or more. A motorhome requires protection from the elements just as a house or a car would. When left out in the environment without proper storage or maintenance, a motorhome, house or car is vulnerable to the moisture and oxidation processes inherent in the environment.

Preventative measures should be taken and preferable situations used when storing a motorhome. Such measures will aid in protecting and preventing a motorhome from the damaging effects caused by an accumulation of moisture.

---

**NOTE: The natural process of moisture in the air condensing will occur with temperature changes of 30° F or more in one day. Humidity readings of 60% or greater will allow the accumulated moisture to remain for extended periods of time.**

**If the motorhome is stored in a location where AC power is not available:**

- Turn off all the appliances.
- Turn off the battery cut-off switch.
- If possible, situate the motorhome so the batteries remain accessible. This allows a battery to be charged or replaced without moving the motorhome.
- Charge the batteries to a full state of charge.
- Turn the main battery disconnects **OFF**.
- When stored outside, use the available DC Volt meters to make a quick reference check of the batteries while the motorhome is in storage. If the motorhome is stored outside, solar panels may offset the parasitic loads.
- Preventative measures should be used if the voltage readings are low. When using preventative measures, taking the motorhome out of storage or moving the motorhome in case of an emergency is a much easier process.

**NOTE: Batteries in a low state of charge will readily freeze. Freezing will damage the battery.**

**CAUTION: A 20 Amp service using light duty extension cords and the required adapters create serious voltage losses. Line voltage loss and the resistance at each electrical connection is a hazardous combination and should be avoided. Damage to sensitive electronic equipment may result!**

**Type of surface to park and store the motorhome on:**

- The type of surface the motorhome is parked upon will affect how much moisture accumulation occurs on the chassis and flooring. Moisture can eventually seep into the interior.
- Parking the motorhome on a grass surface, with the tires supported by blocks, is a perfect situation for moisture to accumulate.
- A gravel covered parking area still allows moisture to evaporate from the ground, through the gravel and to the underside of the motorhome.
- Concrete pads should be sealed to prevent moisture coming up through the concrete flooring.
- Storage buildings with sealed concrete floors, or heated storage facilities, greatly reduce the amount of moisture accumulation and protects the motorhome from moisture damage.

**If the motorhome is stored outdoors:**

- The interior should be heated to help prevent mold and mildew growth. Moisture removing desiccate filter systems are available from hardware and RV supply stores. Place the filter system inside the motorhome to reduce inside moisture condensation or humidity. These systems help control mold and mildew growth.
- Proper winterization of the fresh water system will prevent potential damage in extreme cold.
- Ultraviolet radiation affects soft goods and rubber products such as privacy curtains, window shades and tires. These items should be protected.
- Cardboard templates can be made for the windows to protect these items from exposure to direct sunlight.
- Tire covers are available to protect the sidewall of the tires from cracking. Make sure the tires contain the correct air pressure. Underinflated tires can be damaged.
- Washing the exterior regularly will help control moss accumulation. The clear coat has UV protective substances. Waxing the motorhome twice a year will augment these substances.

**Inspect the motorhome:**

- Perform a full interior inspection for water leaks every two weeks while the motorhome is in storage. Open all cabinet doors looking for signs of dampness or leaks. Inspect the ceiling areas around roof vents or other roof openings.
- The roof and sidewall seams should be inspected and cleaned at least twice a year. **Inspect** for exterior sealant gaps of all roof seams, vents, skylights, roof air conditioners and windows. If necessary, use the proper sealants and recommended application procedures.

**Fuel:** A full tank of fuel will help minimize moisture condensing at the top of the tank. Diesel fuel is an organic material which will develop a microbe growth (black slime). Fuel stabilizers may be added to control microbe growth and degrading of the fuel. Consult the Cummins manual or a Cummins distributor for further detailed information on fuel stabilizers and additives.

**Brakes:** Brakes also suffer from non-use during periods of storage. The bare metal machined surfaces of brake drums or rotors have only a light coating of dust from the brake lining friction material. The brake dust is the only thing protecting the bare metal surfaces from rusting. Only regular brake applications dry the moisture preventing rust on brake drum or rotor surfaces. During periods of non-use, oxygen and moisture oxidize the machined surfaces. Only occasional use keeps these surfaces from oxidizing. Rusty brake drum or rotor surfaces permeate the brake linings upon the first few applications, reducing the friction action of the linings.

**Engine:** Internal combustion engines need to be “exercised” on a regular basis. This will ensure that an adequate supply of lubricating oil coats the cylinder walls and piston rings. Valve and valve seat surfaces also suffer from non-use. Some valves will remain open depending at which part of the combustion cycle the engine has stopped. The heat and cold of the day allows moisture to accumulate through the exhaust system.

**Electric Motors:** Electric motors in the motorhome should be operated occasionally to help lubricate and keep surfaces rotating freely. These items include the roof air conditioners, dash fans, dash blower motor, furnace motors and powered roof vents.

---

### **Winter Storage - Checklist**

- **Plumbing Lines** - Drain and protect by filling with approved RV antifreeze.
- **Fresh Water Tank** - Drain.
- **Body** - Clean and wax. Oil locks and hinges. Repair roof seams as needed.
- **Countertop and Cabinets** - Wash with mild soap and water.
- **Curtains** - Remove and clean according to care specifications.
- **Windows** - To protect the interior fabric from fading, cover windows by pulling blinds, closing shades or using a separate cover such as a sheet.
- **Holding Tank** - Drain and rinse. Close valves.

**NOTE:** Add a small amount of antifreeze to waste holding tanks to keep valves and gaskets lubricated.

- **Drain Traps** - Pour RV antifreeze down all drains.
- **Refrigerator** - Clean and leave both doors propped open. Cover the exterior panels and roof vents.
- **Batteries** - Add distilled water and recharge if needed. Disconnect the cables. Remove the batteries and store them in a cool dry place. Check and recharge as needed. Never park the coach where the battery door cannot be opened.
- **Air Conditioner** - Remove the air filters. Clean or replace.
- **Roof** - Keep clear of snow accumulation or damage may occur.
- **Interior/Exterior** - Storing under cover or indoors helps extend interior and exterior life.
- **Fuel Tank** - Diesel fuel tank should be full of fuel.

## **Removal from Storage**

If the motorhome was properly and carefully prepared for storage, removing it from storage will not be difficult. The following checklist pertains to items or areas which should be checked before operating or moving the motorhome. If the motorhome was not properly winterized, extensive freeze damage or other serious deterioration may have occurred. Consult a dealer or an authorized service center for advice.

- Thoroughly **inspect** the outside of motorhome. Look for animal nests in the wheel wells or in other out of the way places.
- Remove all appliance flue vent covers, ceiling vent covers and air conditioning covers. Be sure the refrigerator openings are free of debris, insect nests, webs, etc.
- Open all doors and compartments. Check for animal or insect intrusion, water damage or other types of damage which may have occurred.
- Check the state of charge of the batteries. If necessary fill the cells with distilled water only and charge as necessary. Inspect the cable ends and terminals. They should be clean and free of corrosion.
- Check all the chassis fluid levels: engine oil, engine coolant, hydraulic fluid reservoir, transmission oil and rear axle oil.
- Start the engine, allowing it to reach operating temperature. Ensure the engine instruments are indicating proper readings.
- While the engine is running check the operation of headlights, taillights, turn signals, back-up lights, license plate light and emergency flasher. Operate the dash air conditioner. If the air conditioner does not work, or the compressor makes unusual noises, have the system checked by a qualified air conditioner technician.
- Shut the engine down. Adjust or add fluids as necessary. **Inspect** the engine for fluid leaks. Look under the motorhome for any other type of fluid leaks.
- Drain, sanitize and flush the fresh water system as outlined in the *Water Systems - Section 6*. **Inspect** the sewer drain hose and connections for leaks. Replace if necessary.
- Operate all faucets and fixtures in the fresh water system. Run a sufficient amount of fresh water through all the water lines and faucets to thoroughly purge any potable antifreeze from the fresh water system.

**NOTE: Discard at least the first two trays of ice from the icemaker to ensure the ice does not contain traces of antifreeze or other contaminants.**

- Open cabinet doors and drawers. **Inspect** for water leaks at joints or fittings. Repair as necessary.
- Operate all 12 Volt lights and accessories. If something does not work there may be a bad 12 Volt circuit breaker or blown fuse.
- Install new batteries in battery operated safety detectors or devices. Test the carbon monoxide, LP-Gas and smoke detectors for proper operation.

- Check that the monitor panel is functioning properly.
- Inspect the 120 Volt electrical system which includes the power cord, inverter/converter all outlets and exposed wiring.

**NOTE: Prepare the generator for operation following the instructions in the Generator Manual.**

- Start and run the generator.
- Confirm that the batteries are charging. Operate the 120 Volt appliances and air conditioners. If an electrical item or appliance is not functioning properly, contact the dealer or an authorized service center to have it evaluated.
- Have a qualified technician **inspect** the LP-Gas system and perform an LP-Gas leak test. The leak test should also include an LP-Gas regulator adjustment (if needed). The test can also verify if the regulator is faulty and should be replaced. Have the LP-Gas tank inspected.
- Operate each LP-Gas appliance. Observe all burner/pilot flames for proper color and size.
- **Inspect** and clean the interior.
- Check the sealant around all roof and body seams and windows. Reseal if necessary.
- **Lubricate** all the exterior locks, hinges and latches with a graphite lubricant.
- Check the windshield wiper blade condition. Check the wiper/washer operation.
- Wash and wax the exterior. Check the body for scratches or other damage; touch up or repair as necessary. Flush the underside thoroughly.
- Run through the operational checks for steering, brakes, engine and transmission. Operate the motorhome slowly during these checks to allow sufficient circulation of fluids and resetting of the components.
- If desired, have the dealer or repair center double-check preparation to make any necessary adjustments and/or correct defects.





# Appliances

## Section 4

<b>APPLIANCES - INTRODUCTION .....</b>	<b>139</b>	<b>AIR CONDITIONER - ROOF.....</b>	<b>155</b>
<b>REFRIGERATOR .....</b>	<b>139</b>	Operating Instructions .....	155
Operating Specifics.....	140	Heat Pump (Opt) .....	156
Inverter Mode Operation .....	141	Return Air Filters.....	156
Control Panel - Two Door.....	141	<b>FURNACE.....</b>	<b>157</b>
Control Panel - Four Door (Opt) .....	142	Operating Instructions .....	157
Icemaker (Opt) .....	144	Using the Furnace.....	158
Doors .....	144	Tips.....	158
Alarm .....	145	If the Furnace Fails to Light.....	159
Interior Light.....	145	<b>WATER HEATER .....</b>	<b>159</b>
Service.....	146	Before Using the Water Heater .....	159
Cooling Unit Fans (Four Door Models) .....	146	Operation .....	160
<b>MICROWAVE/CONVECTION OVEN .....</b>	<b>146</b>	Ignition Module Function.....	161
Cleaning the Microwave/Convection Oven.....	147	Water Heater Bypass .....	162
<b>COOKTOP .....</b>	<b>149</b>	Pressure Temperature Relief Valve .....	162
Operation .....	149	Burner Compartment.....	163
Cooktop Cover .....	150	Tips.....	163
Lighting Top Burners.....	150	Draining & Storage .....	163
Burner Grate.....	150	<b>WASHER-DRYER PREPARED .....</b>	<b>164</b>
Cleaning .....	151	<b>WASHER-DRYER (OPT) .....</b>	<b>165</b>
<b>COOKTOP WITH OVEN (OPT).....</b>	<b>152</b>	Operation .....	166
Lighting Top Burners.....	153	Washer-Dryer Maintenance.....	167
Burner Grate.....	153	Winterizing the Washer-Dryer.....	168
<b>WALL THERMOSTAT .....</b>	<b>154</b>		



---

---

## APPLIANCES - INTRODUCTION

This section covers operation and care of various appliances found in the motorhome. The motorhome is equipped with a refrigerator, cooktop range, microwave, furnace, water heater, roof air conditioner and other optional appliances. Many of these appliances operate on AC or DC current, LP-Gas or a combination of all three.

**Detailed information with CAUTION or WARNING instructions for the various appliances, other than what is found in this section, can be found in the manufacturer's manual.**

**WARNING: Before entering any type of refueling station make sure all LP-Gas operated appliances are off. Most LP-Gas appliances used in recreational vehicles are vented to the outside. When parked close to a gasoline pump it is possible for fuel vapors to enter this type of appliance and ignite, resulting in an explosion or fire. Carbon monoxide gas may cause nausea, fainting or death. Operating an LP-Gas appliance with inadequate ventilation or partial blockage of the fuel can result in carbon monoxide poisoning. Do not store flammable liquids such as lighter fluid, gasoline or propane in the outside refrigerator compartment.**

**NOTE: Features and options vary with floorplans.**

---

## REFRIGERATOR

The refrigerator in the motorhome operates on a different principle than a standard household refrigerator. Knowing these differences should answer questions or solve problems that may arise. A standard household refrigerator uses a compressor to pump refrigerant. This system is efficient as long as 120 Volts AC is available.

The motorhome refrigerator uses a different refrigerant. The refrigerant is heated which causes the refrigerant to circulate and vaporize. Using gravity, the refrigerant returns to the absorber vessel to start the process again. To ensure longevity and proper operation of the refrigerator, follow the specific guidelines in the refrigerator manual. With proper care and maintenance, the refrigerator should provide years of trouble-free service.

**NOTE: Refer to the refrigerator manual for detailed operating and maintenance instructions.**

## Operation Specifics

- The refrigerator operates from LP-Gas or 120 Volts AC electric.
- DC Voltage must be no higher than 15.4 Volts DC or lower than 10.5 Volts DC.
- AC voltage must be no higher than 132 Volts AC or lower than 108 Volts AC.
- It is important to operate the refrigerator only when level. Level the refrigerator (from front view) within 3° side to side and 6° front to back using a torpedo or bulls eye (fence post) level. Place the level inside the refrigerator on the bottom shelf. The level should be within the circle by a half of a bubble. Generally, this is within comfortable living conditions.

**NOTE:** Operating the refrigerator "off level" separates the chemicals that crystallize and block the circulation action of the cooling unit. Damage is cumulative and irreversible.

**WARNING:** Do not use the refrigerator if there is an ammonia smell inside or outside of the refrigerator, or if a yellowish substance appears inside or at the outside access compartment. This can be an indication of a refrigerant leak. Contact an authorized repair facility.

**NOTE:** To reduce the possibility of food spoilage, keep the interior box temperature at or below 54° F. The refrigerator will consume more energy to maintain low temperature, especially in hot, humid climates. Lower temperature may also lead to quicker frost build-up.

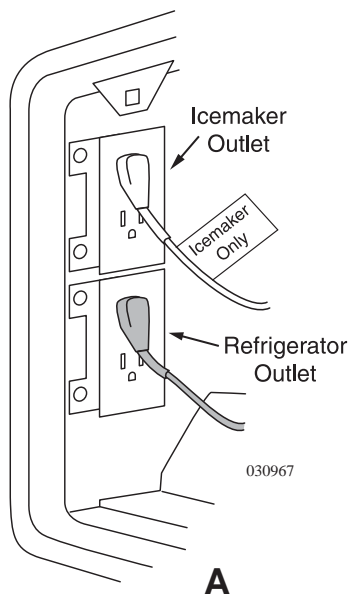

### In order for the refrigerator to operate:

- The house batteries must be charged.
- The primary LP-Gas valve must be on and the electric gas valve must be on.

- The refrigerator AC cords must be plugged in (located outside behind refrigerator access door).
- The water valve must be on if the refrigerator is equipped with an icemaker. (Located below refrigerator, remove vent.)
- If the controls do not light up check the house batteries charge status or see if the 12 Volt wires are plugged into the refrigerator's circuit board (located outside behind refrigerator access door).

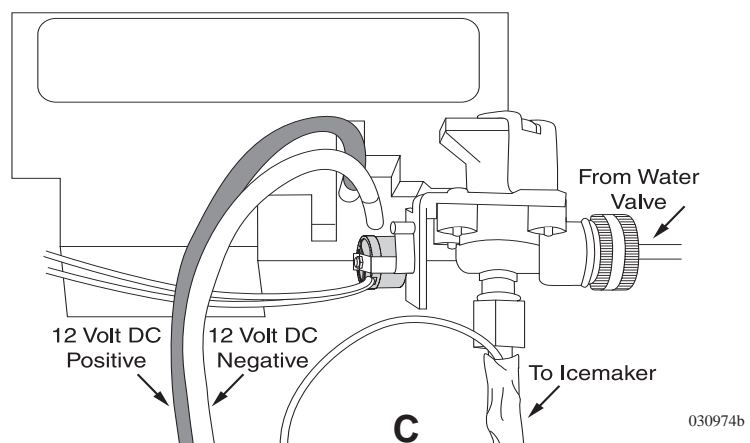
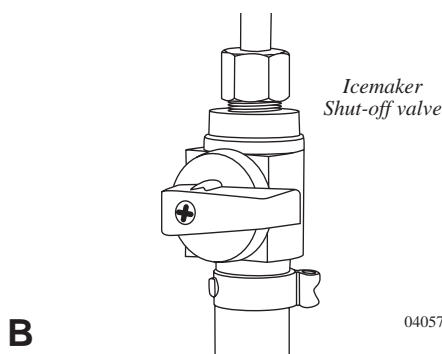

## Inverter Mode Operation

The icemaker requires 120 Volt AC power from shore power, generator or the inverter to operate. The icemaker will not operate on LP-Gas. For example: If dry camping or 120 Volt AC is not available from the generator or from shore power the icemaker can still operate by using the inverter to supply the 120 Volt AC. The refrigerator will not operate on AC Electric when using the inverter and must be running on LP-Gas.

House battery power will be consumed when using the inverter. When possible hook to shore power or start the generator when using the icemaker.

### To Enable this Feature:

1. Select LP-Gas operation for the refrigerator.
2. Allow the freezer to reach ice freezing temperatures. This may take up to 24 hours from initial refrigerator start up.
3. Turn on water pump or city water.
4. Turn the inverter ON.
5. The icemaker will start automatically when the freezer temperature is satisfied.

### To Disable this Feature:

1. Turn the inverter **OFF**.
2. Start the generator or plug into shore power if available
3. Select AC operation for the refrigerator.

## Control Panel - Two Door

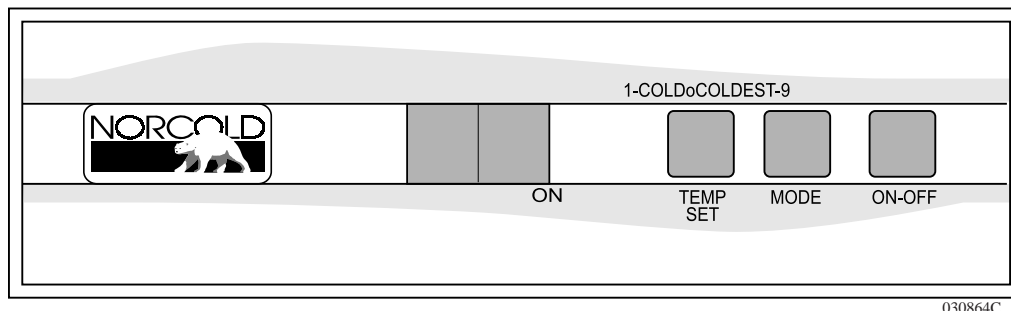

- **LED Display** - This screen is used for mode, temperature and fault code display.
- **ON/OFF Button** - Turns the refrigerator on or off.
  - Push the **ON/OFF** button to start the refrigerator in **Auto** mode.
  - Push and hold the **ON/OFF** button for two seconds to shut it off.
- **TEMP SET Button** - Adjusts the temperature.
  - To adjust push and hold the **TEMP SET** button.
  - Number "9" is the coldest setting.

- **MODE Button** - Controls the operation mode of the refrigerator.
  - Push and hold the **MODE** button to select between Automatic AU, AC or LP operation.

**Manual Mode:** When one of the two manual modes is selected:

1. **AC** = The refrigerator is operating on AC electric.
2. **LP** = The refrigerator is operating on LP-Gas.

**Automatic Mode:**

The refrigerator selects AC power over LP-Gas in **Auto** mode (**AU**). The controls select the energy source in this sequence.

1. When 120 Volts AC is available "**AU AC**" flashes in the display. This indicates the refrigerator is operating on AC electric. After ten seconds, the "**AU AC**" goes off and only a power indicator remains.
2. If 120 Volts AC is not available, "**AU LP**" flashes in the display. This means the refrigerator is operating on LP-Gas.
3. After the refrigerator is operating, press the **TEMP SET** button and set the desired temperature.

If the LP-Gas does not ignite within 30 seconds, the control changes to a different energy source or the gas safety valve closes and **F** displays. Turn the refrigerator off then back on. If the gas does not ignite after several attempts, consult a dealer or authorized Norcold service center.

---

**Control Panel - Four Door (Optional)**

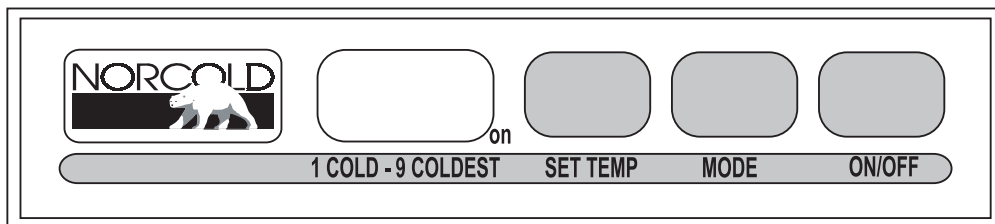

*The Refrigerator Control Panel requires 12 Volt DC to operate.*

030864

- **ON/OFF Button** - Turns the refrigerator on or off.
  - Push the **ON/OFF** button to start the refrigerator in Auto mode.
  - Push and hold the **ON/OFF** button for two seconds to shut it off.
- **LED Display** - This screen is used for mode, temperature and fault code display.
- **MODE Button** - Controls the operation mode of the refrigerator.
  - Push and hold the **MODE** button to select between Automatic AU, AC or LP operation.
- **TEMP SET Button** - Adjusts the temperature.
  - To adjust push and hold the **TEMP SET** button.
  - Number "**9**" is the coldest setting.

**Manual Mode:**

When one of the two manual modes is selected:

1. **AC** = The refrigerator is operating on AC electric.
2. **LP** = The refrigerator is operating on LP-Gas.

**Automatic Mode:** This feature selects AC over LP-Gas operation. If AC discontinues, the alarm sounds and the refrigerator switches to LP-Gas operation. If the refrigerator fails to light, the alarm sounds and a code displays.

- Press and hold the **MODE** button until **AUTO** displays, release the button.
- Press and hold the **TEMP SET** button until the desired temperature displays, release button.
- In **AUTO** mode, AC or LP will remain lit for 10 seconds or when a mode has changed.

If the LP-Gas does not ignite within 30 seconds, the control changes to a different energy source or the gas safety valve closes and **F** displays. Turn the refrigerator off then back on. If the gas does not ignite after several attempts consult a dealer or authorized Norcold service center.

**Tips**

- Cool items first, if possible, before putting them into the refrigerator.
- Keep the doors shut. Know what you want before opening the doors.
- Allow the refrigerator 24 hours of operation before actual use to help get a "head start" with the refrigeration process.
- A box of open baking soda will help absorb food odors.
- Refrigerator icing can be slowed in high humidity if the end of the drain tube is submersed in drip pan.

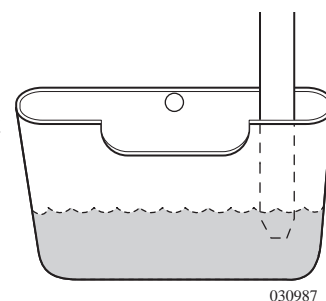

Located behind the outside access.

**Icemaker (Optional)**

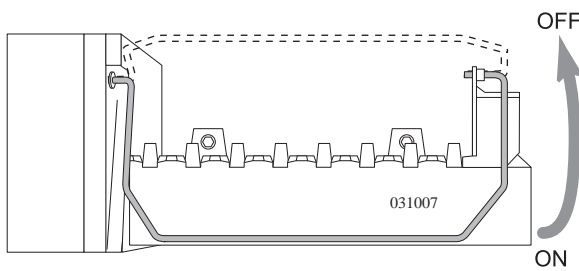

The icemaker works from 120 Volts AC only. The icemaker functions only after the freezer temperature is low enough. City water or the water pump must be on and the valve for the water supply line to the icemaker must be on.

- Pull the metal arm (bail) down to turn the icemaker on.
- Push the arm up to turn the icemaker off.

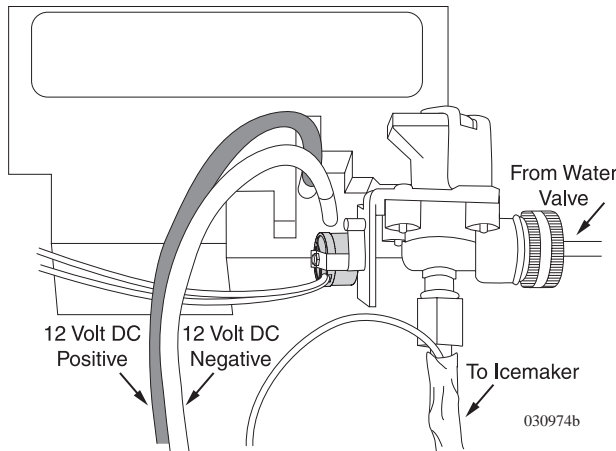

**Water Line Heater:** A thermal disc supplies voltage to heater tape when ambient temperature is less than 38° F (+/- 4°). It shuts off at temperature greater than 48° F (+/- 5°). The water line heater is only for the line from the solenoid to the icemaker. The line from the shut-off valve to the water valve is not protected.

**NOTE:** If the icemaker is in operation while the motorhome is in motion, water may spill out of the ice tray. Raise the icemaker arm to stop ice production while in transit. Do not use the first one or two trays of ice if the refrigerator has been in storage. Ice cubes may have contaminates. Do not operate the icemaker without water pressure supplied to the refrigerator. This can cause damage to the icemaker assembly.

**Doors**

The refrigerator doors use a positive latch that secures the door with a "click" to prevent the door from opening while traveling. The doors use a heating element located in the flapper on the left door (four-door model) or in the door (two-door model). The heating element activates when operating the refrigerator in any mode to help prevent moisture accumulation in high humidity conditions.

When storing the motorhome, the refrigerator has a storage position to lock the doors partially open. This will help reduce odor from mold and bacteria. A completely sealed refrigerator in storage is a perfect environment for mold and bacteria to grow.

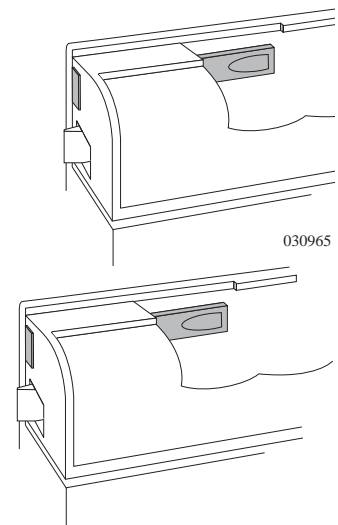



**To Use the Storage Feature:**

- Turn the refrigerator off and remove all items. Leave the drip tray under cooling fins.
- Shorten defrost time by using trays of warm water. Do not use a heating gun, hair dryer or sharp objects to remove frost as these can damage the interior or cooling unit.
- Wash the interior using mild spray cleansers or a solution of liquid dish detergent and warm water. Do not use scouring pads or abrasive cleansers as these can damage the interior finish.
- Rinse with a solution of baking soda and water. Dry with a clean cloth.

**CAUTION:** When defrosting, do not use a hot air blower. Permanent damage could result to plastic parts. Do not use a knife, ice pick or any other sharp instrument to remove ice from the freezer as they can puncture the system.

**Alarm**

The refrigerator uses an audible alarm that will sound for the following reasons:

1. DC or AC voltage is higher or lower than allowed.
2. Refrigerator is set to Auto and 120 Volts AC is discontinued.
3. The refrigerator fails to light on LP-Gas or fails to light after a period of operation.
4. Door is open longer than two minutes.
5. The circuit board detects a failure displaying a code.

**NOTE:** If the alarm sounds, note the code in the LED display and turn the refrigerator off to silence the alarm.

Refer to the manufacturer's manual for the list of codes and their meanings.

**WARNING:** Make sure all flames are extinguished and the LP-Gas valve is off before refueling. LP-Gas and gasoline are highly flammable which can ignite, resulting in an explosion, fire or death. Many states have passed laws regarding having the LP-Gas valve open while traveling. Know the laws for the particular state in which you are traveling.

**Interior Light**

The interior light is located at the top of the fresh food compartment. When the door is open the light will illuminate.

**Bulb Replacement:**

1. Remove the light cover by pulling it toward the front of the refrigerator.
2. Remove the light bulb from the holder.
3. Install a GE#214-2 replacement bulb and install the cover.

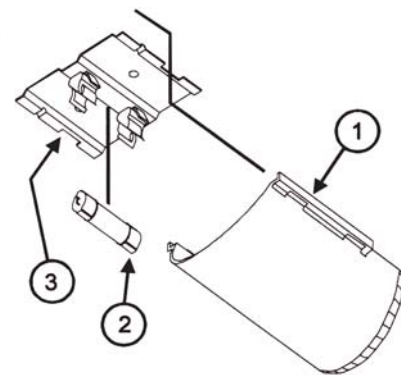

inter light

## **Service**

The LP-Gas function of the refrigerator and LP-Gas pressure will need servicing yearly, depending on use. Over time, the BTU rating of the flame can change, affecting the refrigerator's performance. Ambient temperature and humidity can also affect performance and function. The BTU rating lowers when operating on LP-Gas at an altitude higher than 5,500 feet. This affects the refrigerator's performance. If possible, switch mode operation to AC while at higher altitudes.

---

### **Cooling Unit Fans (Four Door Models)**

The cooling unit is equipped with a pair of cooling fans to help pass air across the cooling unit. These fans start automatically and are audible when in operation.

---

## **MICROWAVE/CONVECTION OVEN**

The microwave/convection oven operates from 120 Volt AC supplied by shore power, the generator or the inverter.

### **Operation Tips:**

- Check the type of cookware being used to see if it is microwave or oven safe depending on the type of cooking being done. Gold paint or glaze may contain a trace amount of gold which is electrically conductive and not compatible for microwave. Hand painted china commonly contains traces of metal.
- The glass tray and roller guide must always be in place during cooking.
- Ensure the door is firmly closed before use.
- If the control pad is not lit, plug another electrical appliance into the same outlet to verify 120 Volt AC power is present. If the test item works, contact an appliance repair facility to have the microwave/ convection oven checked.
- Steam accumulating inside or around the outside of the oven door may occur when the microwave/convection oven is operated under high humidity conditions and in no way indicates a malfunction of the unit. Wipe away steam using a soft cloth.

**Microwave/Convection Oven Facts:** One of the most useful documents for the microwave/convection oven is the manufacturer's operations manual, located in the owner's information file box. Read it carefully and keep it for reference.

A properly functioning microwave/convection oven presents no hazard with ordinary use. Safety features should be kept in good condition. Never attempt to bypass safety interlocks or allow debris or residue to accumulate on the door or oven face. If the oven is damaged, discontinue use.

Oven adjustments or repairs should be made by qualified service personnel. Check the microwave/convection oven owner's manual for maintenance tips and other information. Remember to register the microwave/convection oven with the manufacturer.

**WARNING:** If a fire flares up when using the cooktop, turn off the ventilation fan. The fan may spread the flame. If the ventilation fan has started automatically from a heated cooktop it can not be manually turned off. Turn off the microwave/convection oven AC circuit breaker to prevent the flame from getting up into the oven and spreading the fire.

**NOTE:** When dry camping, minimize using the inverter to operate the microwave/convection oven due to the high rate of battery consumption.

**NOTE:** The microwave/convection oven is for food preparation only. Do not use the microwave/convection oven to dry clothes, newspapers, shoes or other items.

### ***Cleaning the Microwave/Convection Oven***

The exterior of the microwave/convection oven is plastic and metal. The interior is metal. Do not clean with scouring pads, harsh or abrasive cleaners, chemical cleaners or petroleum based thinners that can damage the finish. Use mild soap and water with a damp cloth or paper towel to remove stains or spills. When cleaning the touch pad, open the door to prevent accidental operation. Use mild soap and water with a soft cloth. Avoid using excess amounts of water on the touch pad. The turntable plate and oven racks are dishwasher safe.

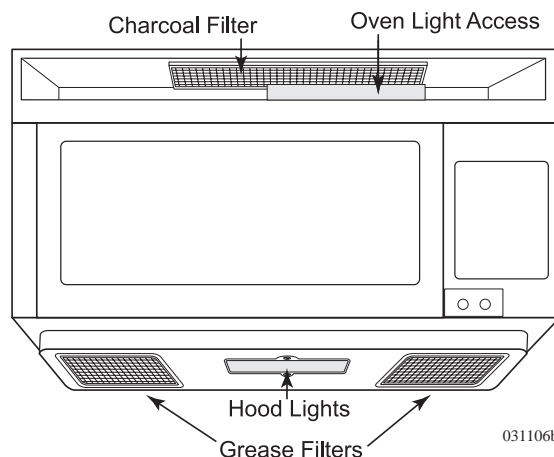

**Charcoal Filter:** Depending on use the charcoal filter should be replaced every 6 to 12 months. Use the following procedure to remove the louvers to replace the charcoal filter and oven light.

1. Remove power to the microwave/convection oven.
2. Remove the screws securing the louver.
3. Insert a flat edge screwdriver over each tab pressing downward and move the louver away from the microwave/convection oven.
4. Remove and replace the charcoal filter ensuring the filter is positioned on the supporting tabs.
5. Replace louver and mounting screws.

#### **Oven Light:**

1. Remove the louver as indicated above.
2. Slide the metal light cover forward and lift upwards.
3. Remove the light bulb and replace only with an equivalent watt bulb. **DO NOT EXCEED 30 WATTS.**
4. Replace light cover, louver and mounting screws.

**Hood Light:**

1. Remove power to the microwave/convection oven.
2. Remove the screw securing the light cover.
3. Remove the light bulb and replace only with an equivalent watt bulb. DO NOT EXCEED 30 WATTS.
4. Close the cover and re-secure with screw from step two.

**CAUTION: Light cover may be hot. Do not touch glass with lamp ON. Never use the light for prolonged periods, such as a night light.**

**Cleaning Tips:**

- Turn the oven off before cleaning.
- Cover food while cooking to keep food spattering to a minimum.
- Clean up all spills or spatters before they dry. Wipe up food spatters or spilled liquids with a damp cloth. Mild detergent may be used for stubborn spills. Do not use harsh detergent or abrasive cleaner.
- It is occasionally necessary to remove the glass tray for cleaning. Wash the tray in warm, sudsy water or in a dishwasher.
- The roller guide and oven cavity floor should be cleaned regularly to avoid excessive noise. Wipe the bottom surface of the oven with mild detergent water or window cleaner and then dry. The roller guide may be washed in mild sudsy water.
- Food odors may linger inside oven. To help eliminate odors, combine the juice and the peel from one lemon, several whole cloves and 8 oz. of water into a two cup bowl. Place in oven on high power; bring to a boil for several minutes. Let cool in the oven for several minutes.
- Clean the outside oven surface with soap and water. Wipe away any residue using a damp cloth. Dry with a soft cloth. To prevent damage to the operating parts inside the oven, do not allow water to seep into the ventilation openings.
- If the control panel becomes wet, clean with a soft, dry cloth. Do not use harsh detergents or abrasive when cleaning the control panel.

**Grease Filters:** Operating the microwave/convection oven without the grease filters in place can damage the unit. Grease filters should be cleaned at least once a month. To remove the filters, use the pull-tab to slide the filter to the end of the opening and tip down. Soak the filters in the sink or in a dishpan filled with hot water and detergent.

- Do not use ammonia or other alkali-based products that may darken the filter material.
- Agitate the filter. Use a scrub brush to remove caked on grease.
- Rinse the filter thoroughly and shake dry. Place the filter back into the opening, tip upward and slide filter to the end of the opening. Lock in place. Be careful not to kink or warp the filter upon installation.

**COOKTOP**

The cooktop uses LP-Gas only as a fuel source. The burners use a piezo type igniter. The cooktop should be used for cooking purposes only and not as a heating source. When the burner valve is opened the fuel source flows through the valve into the mixture tube. The fuel passes by a hole or venturi in the mixture tube, which draws air in with the fuel for a proper fuel/air ratio. The flame should have a blue appearance with a lighter blue defined flame at the burner head. A yellow flame or yellow tips indicate a rich fuel mixture, which can leave a black color or carbon on the bottom of a pot or pan.

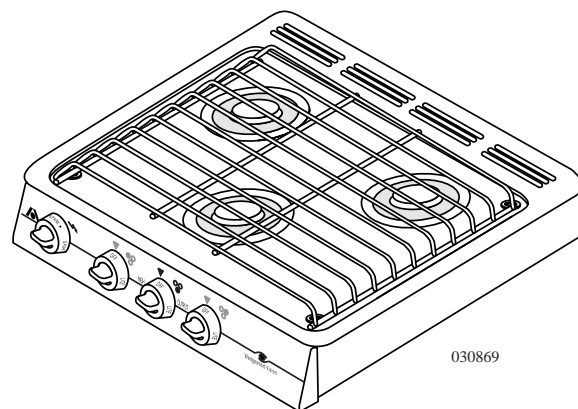
**Operation**

**The cooktop will operate when the following conditions have been met.**

1. The primary LP-Gas valve on the LP tank is open.
2. The battery cut-off switch is on.
3. The electric switch, located at the remote fill, is on.

To use the cooktop, open the desired burner valve and rotate the igniter knob, clockwise, at the left hand side of the stove.

Before cooking on the range top the cover must be in full upright and folded position. Push the cover toward the outside wall to prevent it from falling onto the range top during cooking.

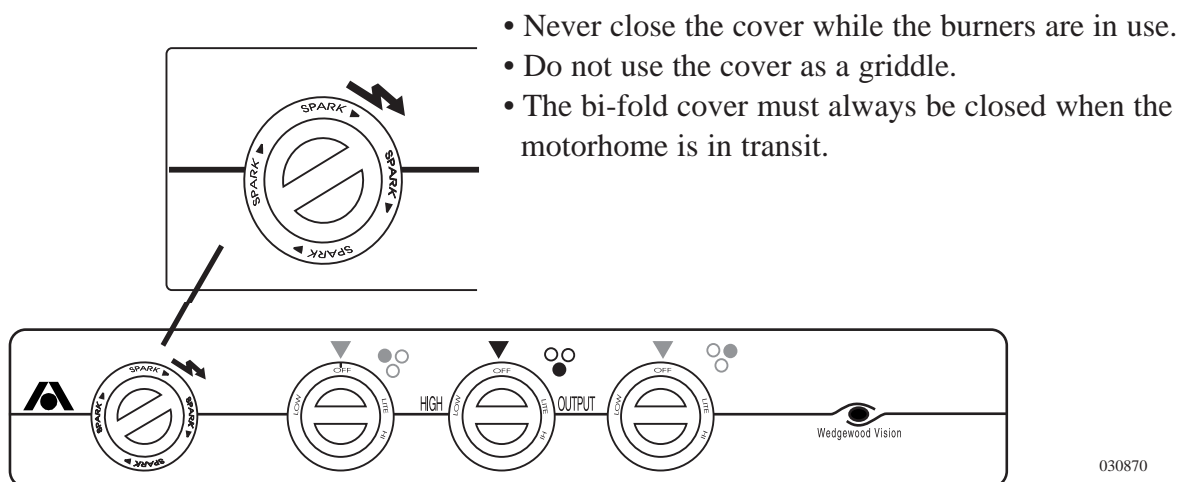

**WARNING: Do not the heat motorhome interior with the cooktop or oven. Gas combustion consumes oxygen inside the motorhome. Carbon Monoxide is an odorless, colorless and highly poisonous gas.**

## Cooktop Cover

**To Lift Cover:** Lift the cover then fold. The cover will lock into the upright position.

**CAUTION: Lid is heavy.**

**To Close Cover:** Allow the cooktop to cool to room temperature before closing cover. Raise cover arms from lock position, lower and unfold cover.

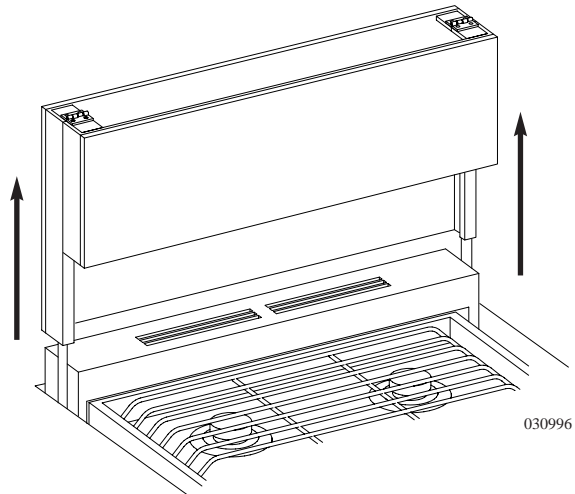

---

## Lighting Top Burners

- Turn the appropriate burner knob counterclockwise to **LITE**. Do not attempt to light more than one burner at a time.
- Turn the **SPARK** knob clockwise one click. If the burner fails to light, continue turning the **SPARK** knob clockwise until the burner lights.
- Turn the burner knob clockwise to **OFF**, to turn the burner off.

**WARNING: Top cover must be open when the cooking surface is in operation. Do not cover the oven vent openings while the oven is in operation.**

---

## Burner Grate

The burner grate is attached to the cooktop cover by two spring clips located on the underside of the cooktop cover. The burner grate can be separated from the cooktop cover for cleaning purposes. Place a towel down onto the countertop next to the cooktop. Lift the cooktop cover up by pushing cover towards rear of cooktop. Lift cover at the front edge. Place the cooktop cover upside down onto the towel. Squeeze both of the grate spring clips to remove the grate from cooktop cover.

**WARNING: If you smell gas, extinguish all open flames and turn off the main gas supply. Liquid propane is highly volatile, highly explosive and extremely dangerous. Explosion, fire, property damage, injury or death can result. Propane is a “heavy” gas and will lay on the floor and “hide” in corners. Open all windows and doors. Do not touch any electrical switches. They may cause a spark which can ignite. Contact a qualified service center to have the problem correctly diagnosed and repaired before resuming operation.**

**Operation Tips:**

1. A yellow flame is an indication of incorrect fuel/air ratio. Lowered BTU output and carbon build up can occur.
2. Flame appearance may change and BTU output will lower when operating the cooktop at an altitude above 5,000 feet. Allow extra cooking time.
3. Do not allow the tips of the flame to extend beyond pan or pot edge. When this occurs heat is wasted and possibility of injury increases.
4. Remove cooktop cover to help keep the underside of the cooktop clean. Place strips of aluminum foil on the cooktop floor pan and under burners. Do not restrict air flow of mixture tubes.
5. Pre-heat the oven for 10 minutes prior to use.

**Cleaning**

- Clean all surfaces as soon as possible after boil overs or spillovers.
- Use warm soapy water to clean the burner grates, cooktops, painted surfaces, porcelain surfaces, stainless steel surfaces and plastic items on the range or cooktop. Grit or acid-type cleaners may ruin the surface.
- Use only non-abrasive plastic scrubbing pads.
- Do not allow foods containing acids (such as lemon or tomato juice, or vinegar) to remain on porcelain or painted surfaces. Acids may remove the glossy finish. Wipe up egg spills when cooktop is cool.
- Allow porcelain surfaces to cool before cleaning. Burns from the heated surface may occur or the cooktop porcelain can crack.

Regular cleaning with a soft cloth and a warm detergent solution is generally enough to keep the cooktop clean. Wash, rinse and dry with a soft cloth. Thoroughly clean the cooktop when it is cool. Use a dry cloth or paper towel while the surface is warm to the touch to clean splatters or spills. Cleaning will be more difficult if spills bake on to the surface. Glass cleaner sprayed on a paper towel should be used for the cooktop surface. Do not spray glass cleaner directly on the surface. **DO NOT** use abrasive cleaners or steel wool. Harsh cleansers like bleach, ammonia and oven cleaner should **NEVER** be used. The surface burner grate and caps should be cleaned using the same guidelines as the cooktop surface.

**Porcelain Enamel:** Porcelain enamel, a type of glass fused on steel at a very high temperature, is not extremely delicate but must be treated as glass. Sharp blows, radical surface temperature changes, etc., will cause enamel to chip or crack. Some foods such as vinegar, lemon juice, tomatoes and milk contain acids which can dull the finish of the enamel. To avoid dulling the finish, wipe up the spill before it is baked on. The surface is glass and must be given consideration when cleaning. Steel wool and coarse, gritty cleanser will scratch or mar the surface. Any gentle kitchen cleanser powder or grease cleaner will be suitable. For further information on care of the porcelain, call “*Hopes Cultured Marble Polish*” at 800-325-4026.



## COOKTOP WITH OVEN (OPTIONAL)

The cooktop range/oven uses LP-Gas only as a fuel source. The burners use a piezo type igniter. The cooktop should be used for cooking purposes only and not as a heating source. When the burner valve is opened the fuel source flows through the valve into the mixture tube. The fuel passes by a hole or venturi in the mixture tube, which draws air in with the fuel for a proper fuel/air ratio. The flame should have a blue appearance with a lighter blue defined flame at the burner head. A yellow flame or yellow tips indicate a rich fuel mixture, which can leave a black color or carbon on the bottom of a pot or pan.

### The cooktop operates under the following conditions:

1. The primary LP-Gas valve on the LP tank is open.
2. The battery cut-off switch is on.
  - The oven may be used with the cooktop cover down.
  - Push in the oven control knob and rotate counterclockwise to **PILOT ON**.
  - Light the oven pilot located near the back of the oven, under the broiler shelf and to the left of the oven burner.
  - Set the oven control knob to **PILOT ON** to maintain the pilot flame. The oven and broiler are now ready for operation. The oven pilot has been factory set and requires no further adjustment.
  - To extinguish the oven pilot push in the oven control knob and rotate clockwise to **OFF**.

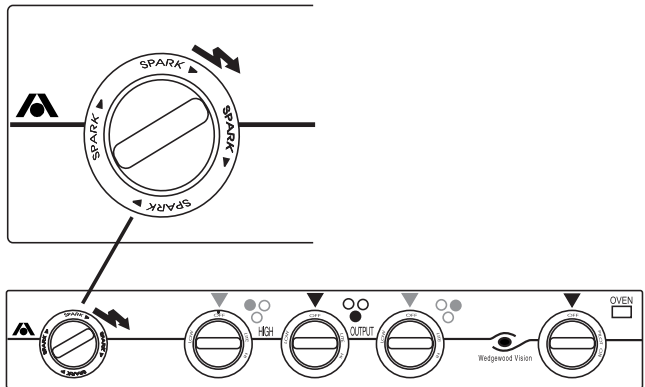

030185

**WARNING: Extinguish all pilots when refueling or traveling. Do not block vents in oven with cookware or other objects.**

To use the cooktop open the desired burner valve and rotate the igniter knob, clockwise, at the left hand side of the stove.

Before cooking on the range top the cover must be in full upright and folded position. Push the cover toward the outside wall to prevent it from falling onto the range top during cooking.

- Never close the cover while the burners are in use.
- Do not use the cover as a griddle.
- The bi-fold cover must always be closed when the motorhome is in transit.

**WARNING: Do not heat the motorhome interior with the cooktop or oven. Gas combustion consumes oxygen inside the motorhome. Carbon Monoxide is an odorless, colorless and highly poisonous gas.**



**Lighting the Burners**

- Turn the appropriate burner knob counterclockwise to **LITE**. Do not attempt to light more than one burner at a time.
- Turn the **SPARK** knob clockwise one click. If the burner fails to light, continue turning the **SPARK** knob clockwise until the burner lights.
- Turn the burner knob clockwise to **OFF**, to turn the burner off.

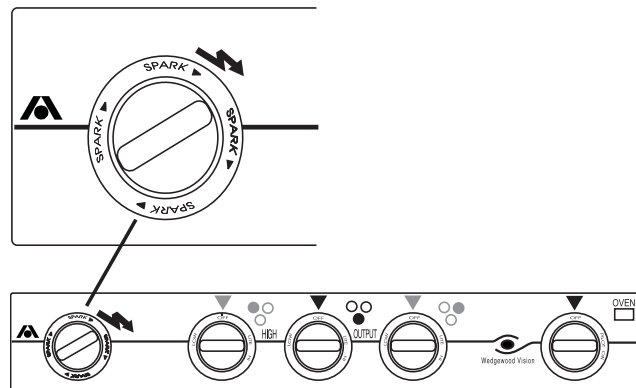

030185

**WARNING: Top covers must be removed when the cooking surface is in operation.**

**Burner Grate**

The burner grate is attached to the cooktop cover by two spring clips located on the underside of the cooktop cover. The burner grate can be separated from the cooktop cover for cleaning purposes. Place a towel down onto the countertop next to the cooktop. Lift the cooktop cover up by pushing cover towards rear of cooktop. Lift cover at the front edge. Place the cooktop cover upside down onto the towel. Squeeze both of the grate spring clips to remove the grate from cooktop cover.

**WARNING: If you smell gas, extinguish all open flames and turn off the main gas supply. Liquid propane is highly volatile, highly explosive and extremely dangerous. Explosion, fire, property damage, injury or death can result. Propane is a “heavy” gas and will lay on the floor and “hide” in corners. Open all windows and doors. Do not touch any electrical switches. They may cause a spark which can ignite. Contact a qualified service center to have the problem correctly diagnosed and repaired before resuming operation.**

**Operation Tips:**

- A yellow flame is an indication of incorrect fuel/air ratio. Lowered BTU output and carbon build up can occur.
- Flame appearance may change and BTU output will lower when operating the cooktop at an altitude above 5,000 feet. Allow extra cooking time.
- Do not allow the tips of the flame to extend beyond pan or pot edge. When this occurs heat is wasted and possibility of injury increases.
- Remove cooktop cover to help keep the underside of the cooktop clean. Place strips of aluminum foil on the cooktop floor pan and under burners. Do not restrict air flow of mixture tubes.
- Pre-heat the oven for 10 minutes prior to use.

**Cleaning Tips:**

- Clean all surfaces as soon as possible after boil overs or spillovers.
- Use warm soapy water to clean the burner grates, cooktops, painted surfaces, porcelain surfaces, stainless steel surfaces and plastic items on the range or cooktop. Grit or acid-type cleaners may ruin the surface.
- Use only non-abrasive plastic scrubbing pads.
- Do not allow foods containing acids (such as lemon or tomato juice, or vinegar) to remain on porcelain or painted surfaces. Acids may remove the glossy finish. Wipe up egg spills when cooktop is cool.
- Allow porcelain surfaces to cool before cleaning. Burns from the heated surface may occur or the cooktop porcelain can crack.

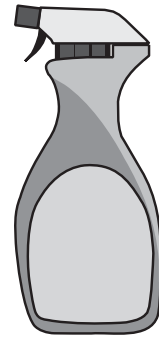

*Glass Cleaner should be applied to the cooktop surface using a paper towel. Do not spray cleaner directly on the surface.*

Regular cleaning with a soft cloth and a warm detergent solution is generally enough to keep the cooktop clean. Wash, rinse and dry with a soft cloth. Thoroughly clean the cooktop when it is cool. Use a dry cloth or paper towel while the surface is warm to the touch to clean splatters or spills. Cleaning will be more difficult if spills bake on to the surface. Glass cleaner sprayed on a paper towel should be used for the cooktop surface. Do not spray glass cleaner directly on the surface. **DO NOT** use abrasive cleaners or steel wool. Harsh cleansers like bleach, ammonia and oven cleaner should **NEVER** be used. The surface burner grate and caps should be cleaned using the same guidelines as the cooktop surface.

**Porcelain Enamel:** Porcelain enamel, a type of glass fused on steel at a very high temperature, is not extremely delicate but must be treated as glass. Sharp blows, radical surface temperature changes, etc., will cause enamel to chip or crack. Some foods such as vinegar, lemon juice, tomatoes and milk contain acids which can dull the finish of the enamel. To avoid dulling the finish, wipe up the spill before it is baked on. The surface is glass and must be given consideration when cleaning. Steel wool and coarse, gritty cleanser will scratch or mar the surface. Any gentle kitchen cleanser powder or grease cleaner will be suitable. For further information on care of the porcelain, call “*Hopes Cultured Marble Polish*” at 800-325-4026.

## WALL THERMOSTAT

One comfort control operates the HVAC (Heating, Ventilating and Air Conditioning) system. The comfort control is located in the hallway on the monitor panel. The comfort control will operate roof air conditioner functions and LP-Gas furnace operation. The comfort control uses a liquid crystal display to show the current mode status.

There are five different functions of the HVAC system: OFF, FAN, COOL, HEAT PUMP (optional) and FURNACE. These are selected by repeat pressing of the MODE button. The FAN button controls the fan speed of the roof air conditioner. Two speeds are available: Low and High. Fan speed control applies only to the blower speed of the roof air conditioner. Selecting the fan speed Auto adjusts the fan speed automatically, depending on temperature set point and actual temperature in a selected zone.

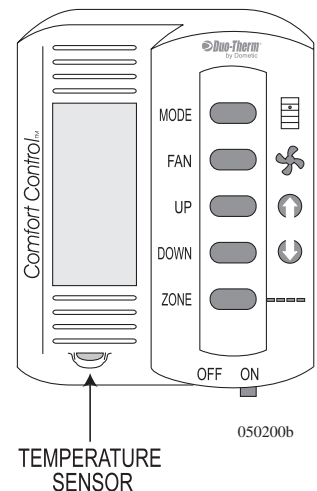

The motorhome is divided into two operating Zones, the living room and the bedroom. The living room is Zone One. The bedroom is Zone Two. The comfort control must be in Zone 1 for the furnace to operate. Press the Zone button to change zones. The selected zone will flash. The UP or DOWN buttons control the temperature in any mode.

**NOTE: The Comfort Control must be ON to operate any HVAC function. Do not select conflicting modes of operation. One zone cannot be on COOL while another zone is set to FURNACE.**

**NOTE: The motorhome will not heat or cool faster by selecting a very high or very low temperature setting.**

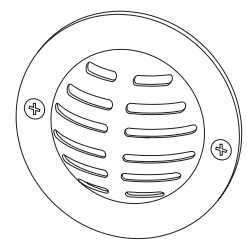

REMOTE  
TEMPERATURE SENSOR

030950c

## AIR CONDITIONER - ROOF

The roof air conditioners operate from 120 Volts AC only, by shore power or the generator. Operations are controlled by the 12 Volt DC comfort control. The electronics in the comfort control use a telephone style patch cord to send low voltage signals to the roof air conditioner's circuit board. The circuit board controls the desired roof air functions and furnace operation. The refrigeration operation principle of the roof air conditioner is the same as the dash air conditioner or a household type refrigerator, functioning as an enclosed system. The compressor pumps refrigerant into a condenser as high-pressure vapor. A condenser expels heat from the vapor into the atmosphere. Vapor condenses to high-pressure liquid. The liquid is forced through a metered capillary tube and then into the evaporator or low side pressure. The refrigerant changes from liquid to vapor as the refrigerant extracts heat. The compressor pumps the vapor to the condenser repeating the cycle. Operating the air conditioner in HEAT PUMP (optional) mode reverses the cycle. Reversing the refrigerant flow blows heated air into the interior of the motorhome. There are ambient temperature operating limitations in HEAT PUMP (optional) mode.

**NOTE: The air conditioning system freezes moisture in the air. It is recommended to set the blower fan speed to high when operating in high humidity.**

### Operating Instructions

**Roof air conditioner operates only when following needs are met.**

- 120 Volts AC, from either shore power or the generator, is supplied.
- The battery cut-off switch is in the **ON** position and house batteries are charged.

**Fan Operation:** Circulates the interior air by using the roof air conditioner blower. The fan speed controls the roof air conditioner blower speed in the following modes: **FAN**, **COOL** or **HEAT PUMP (Optional)**.

- Press the **MODE** button repeatedly until **FAN** is displayed.
- Press the **FAN** button to select the desired fan speed.

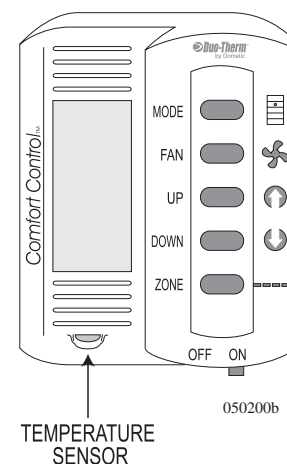

TEMPERATURE  
SENSOR

050200b

### Air Conditioner Operation:

- Press the **ZONE** button to select Zone 1 (front roof A/C) or Zone 2 (rear roof A/C).
- Press the **MODE** button repeatedly until **COOL** is displayed.
- Set desired fan speed by pressing the **FAN** button.
- Set desired cooling temperature by pressing the **UP** or **DOWN** buttons.

**NOTE:** The compressor will engage approximately two minutes after blower motor activation. This prevents accidental compressor activation against high pressure.

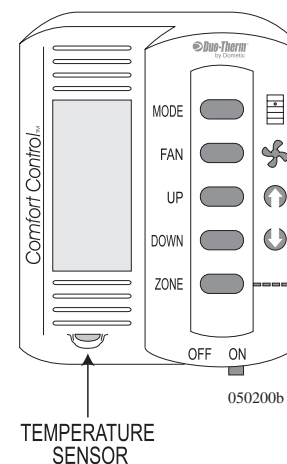

---

### Heat Pump (Optional)

The Heat Pump mode supplies heat by using the air conditioner. The air conditioning principle is reversed, supplying heated air to the ceiling registers instead of refrigerated air. There are ambient temperature limitations of Heat Pump mode.

**NOTE:** The roof air conditioner will not operate in HEAT PUMP mode with ambient temperatures at or below 30° F.

If the Heat Pump mode is selected at or below 30° F., or if operating in Heat Pump mode and temperature drops to 30° F., the air conditioner will stop Heat Pump operation and **AUX HEAT** will be displayed. The furnace will be selected as the auxiliary heat source and will begin operation. The furnace will remain the primary heat source until ambient temperature rises above 42° F. When ambient temperature is between 30 to 42° F., a defrost cycle is initiated approximately every 40 minutes of compressor operation. The blower motor will stop for five minutes and **DEFROST** will be displayed. After the defrost cycle the Heat Pump operation will resume.

### Heat Pump Operation:

- Battery cut-off switch must be in the **ON** position.
- Slide the **ON/OFF** switch to the **ON** position.
- Press the **MODE** button repeatedly until **HEAT PUMP** is displayed.
- Set desired fan speed by pressing the **FAN** button.
- Press the **UP** or **DOWN** buttons to set desired heating temperature.
- Select Zone 1 or Zone 2, using the **MODE** button.

---

### Return Air Filters

Frequently clean the return air filters located inside the motorhome behind the intake vent covers. Firmly grasp the leading edge and push back on both tabs. Never run the air conditioner without the return air filters in place. Dust and other particles will plug the evaporator core and substantially reduce the performance of the air conditioners.

**To Clean:**

- Wash filters in warm soapy water. Do not use solvents.
- Rinse filters thoroughly with fresh water. Allow them to dry.
- Install filters and secure the covers.

---

**FURNACE**

The furnace and related components are 12 Volt DC operated, using LP-Gas as the fuel source. Electronic circuitry (automatic ignition) is used to ignite the burner. The furnace uses outside air for the burner combustion and exhaust is expelled through the outside vent. Inside air is drawn into the furnace and blown across the internal heat exchanger. Heated air is then discharged through ducted hoses which can be run throughout the motorhome.

**CAUTION: Do not store any items/materials in furnace area. Restricted air flow may hamper furnace operation leading to failure and/or fire hazard.**

**WARNING: IF YOU SMELL GAS extinguish all open flames and turn off the main gas supply. Liquid propane is a highly volatile, extremely dangerous gas. It can explode or ignite, which may result in property damage, injury or death. Propane is "heavy" and can "float" on the floor or "hide" in corners. Open all windows and doors. Do not touch electrical switches. They may spark, which can ignite. Keep all open flames, spark producing devices and smoking material out of the area. Contact a qualified service center to have the problem correctly diagnosed and repaired before resuming operation.**

---

***Operating Instructions***

The furnace operates in the following manner: The wall thermostat sends a signal to the front roof air conditioner circuit board, which closes a relay. Closing a relay sends an electrical signal to the furnace to begin the ignition cycle. There is a small time delay before the blower motor begins. Once the blower motor attains a predetermined speed it will close the sail switch. The sail switch, which is now closed, sends the electrical signal through a high temperature protection switch, then to the automatic ignition circuit board. After the thermostat is satisfied, the gas valve closes and extinguishes the burner. The blower motor stops approximately two or three minutes after cool down.

**The furnace will operate when the following conditions have been met.**

1. The LP-Gas primary valve on the LP tank is open and the LP-Gas valve at furnace is on.
2. The battery cut-off switch is in the ON position.
3. The house batteries in the motorhome are fully charged.

**NOTE: The automatic ignition circuit board will attempt to light the burner three times before the ignition board will go into "lock-out." If the burner does not light, the furnace blower motor will continue to run and the wall thermostat will have to be cycled off.**

## Using the Furnace

- Slide the ON/OFF switch to the ON position.
- Press the ZONE button to select Zone 1
- Select the Furnace mode on the Comfort Control using the MODE button.
- Select the desired temperature using the UP and DOWN arrow buttons.

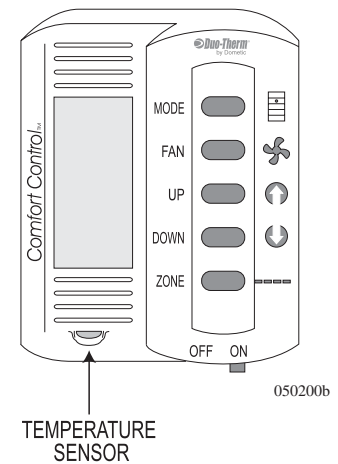

## Tips

- After storage the furnace may produce a musty smell during the first couple of cycles.
- Operating the furnace at an altitude above 5,000 feet reduces the BTU output due to air/fuel ratio.
- The furnace will periodically need to be serviced by a qualified technician. If the furnace exhibits unusual symptoms or noises, or has an unusual odor when operating, have the furnace checked or serviced.
- If the blower fails to operate, verify the batteries are charged and fuses are good. If so use a coin or screwdriver to open outside access doork and turn the reset switch to off and then to reset.

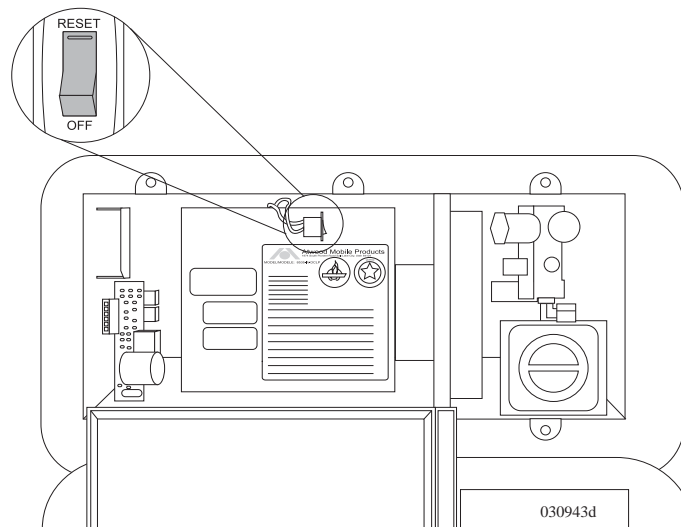

**CAUTION:** It is not advisable to use the furnace to heat the inside of the motorhome during transit.

**NOTE:** When washing the exterior of the motorhome, avoid a direct stream of water into the outside furnace vents. This can cause damage to the furnace.



**If the Furnace Fails to Light**

If the furnace fails to light make sure the LP-Gas primary supply valves are open and the LP-Gas switch is turned on. The furnace will not light if the blower motor is not spinning to its specified speed. This may be due to a low house battery charge condition.

**To Charge the House Batteries:**

1. Hook-up to shore power.
2. Start the generator.
3. Start the main engine to charge the batteries.

**WARNING: If you smell gas and the blower motor is spinning do not attempt additional furnace operation as this may result in an explosion, fire or personal injury. Contact a qualified technician.**

**WATER HEATER**

The water heater uses two different methods to heat water: (1) 120 Volt AC, supplied either by shore power or the on board generator (2) LP-Gas. The 120 Volt AC uses a heating element similar to the type used in a house water heater. The 120 Volt AC method is efficient if shore power is available. An automatic ignition circuit board, operated by 12 Volt DC, controls the LP-Gas. Two thermostats control water temperature: One for the 120 Volt and the other for the LP-Gas. The thermostat temperatures are preset by the water heater manufacturer and are not adjustable.

Water is pumped into the bottom of the water heater tank where it is heated and discharged out of the top upon use. For ease of draining the tank during winterization, the water heater is equipped with a pressure-temperature valve, bypass valve and drain plug.

**NOTE: Do not operate the water heater without water in the water heater tank. Damage to the thermostats and electric heating element can occur.**

**Before Using the Water Heater**

Before using the water heater, purge all trapped air from the water system and water heater.

**To Purge the Air and Pressurize the System:**

- If applicable, turn the water heater Bypass Valve (located at the back of the water heater) to Normal Flow. If necessary replace drain plug.
- Fill the fresh water tank or hook to city water.
- Turn on the water pump or city water.
- Turn on the hot and cold valves for each faucet, one at a time. Operate each faucet, inside and outside the motorhome, until a steady stream of water with no air bubbles or air pockets are present. Do not operate the water heater until the water system is purged of air.
- After the system pressurizes, inspect the water heater and water system for leaks.

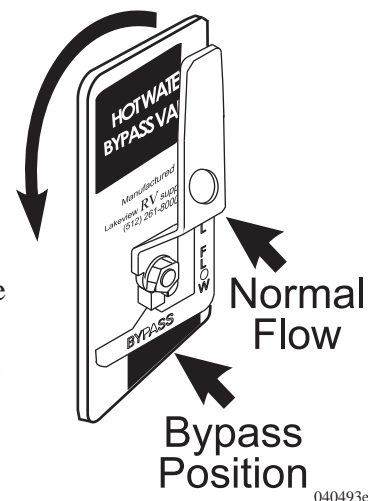

040493e

**CAUTION:** After purging the water lines and water heater, air may still be present. Use caution upon opening a hot water faucet after the first heat cycle of the water heater.

**WARNING:** IF YOU SMELL GAS extinguish all open flames and turn off the primary LP-Gas valve. Do not touch any electrical switches. They may cause a spark that can ignite. Open all windows and doors. Evacuate the motorhome. Propane is a "heavy" gas and will lay on the floor and "hide" in corners. Liquid propane is highly volatile, explosive and extremely dangerous. Explosion, fire, property damage, injury or death can result. Contact a qualified service center to have the problem correctly diagnosed and repaired before resuming operation.

## Operation

### Water Heater Operation:

- Turn on the battery cut-off switch at the entry door.
- 120 Volt AC is supplied from shore power or the generator.
- The house batteries are charged.
- The primary LP-Gas valve on the LP tank is open and the electric LP valve is on.
- Turn on the Master On/Off switch located on the back of the water heater.

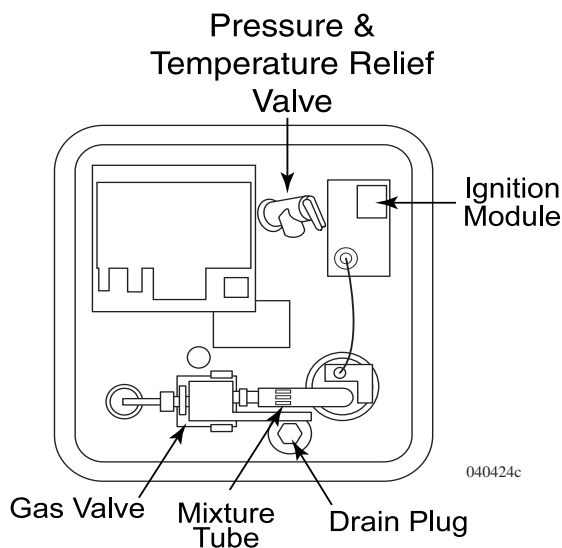

### Heating Water with 120 Volt AC:

- Have either shore power (preferable) or the generator supplying AC voltage.
- Turn on the Water Heater 120 V switch.

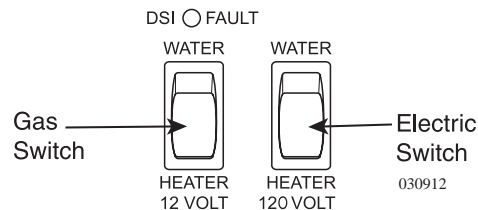

### Heating Water with LP-Gas:

- Make sure the primary LP-Gas valve is open and the electric LP valve is on.
- Turn on the water heater 12 V switch. The indicator light on the switch will illuminate briefly then go out when the burner ignites. The burner will make an audible "roar" when lit.
- The automatic ignition circuit board will attempt three ignition cycles to light the burner. If the burner does not light after the third attempt, the circuit board will "lock-out" and the indicator light on the switch will glow steady.
- Check the level of LP-Gas in the tank and make sure the primary LP-Gas valve is on. Cycle the LP switch Off then back On to reset the ignition board.

**NOTE:** The LP-Gas and AC electric functions may be on at the same time. This will speed the recovery process of heating water for large volume use.

**CAUTION:** It is recommended not to operate the water heater on LP-Gas while the motorhome is in transit. Be sure the water heater is off before refueling.



---

**WARNING:** Before beginning any service or work on the water heater make sure the LP-Gas is turned off, the 120 Volt AC source has been disconnected and the 12 Volt DC source has been disconnected. Failure to do so can result in explosion, fire or injury.

**Indicator Lamp:**

- Illuminates briefly when the LP switch is turned on, ignition occurs and the lamp goes out.
- If the burner does not light within 6 to 9 seconds the ignition board will attempt two more ignition cycles. If the burner does not light after the third attempt, the indicator lamp glows steady.

---

**Ignition Module Function**

The LP-Gas On/Off switch controls the ignition circuit water heater.

The indicator lamp illuminates under the following conditions:

- Upon initial start-up the lamp illuminates briefly, ignition occurs and the lamp goes out.
- If the burner does not light within six to nine seconds, the ignition board will lock out and the indicator lamp will glow steady.

The next portion of the operation is controlled by the direct spark ignition (DSI) system, as power is applied to the DSI board. The system will do the following:

1. The board has a timing circuit, which allows six to nine seconds for ignition to occur.
2. Initially the board supplies current to the gas valve. At the same time, it produces a high-voltage current supply to the electrode to produce a spark at the burner.
3. The board will also confirm the presence of a flame.

If the flame is not sensed within six to nine seconds, the module board will go into lock out. Flame sensing is through the spark wire.

The Thermostat-Limit controls the power to the module board. At 130° F, the thermostat will open shutting off the burner. If the thermostat fails, the safety High Temperature limit switch open, and requires manual resetting.

## Water Heater Bypass (Not on Units with Optional "Prevent-A-Freeze" System)

The bypass valve is located at the back of the water heater. Turning the valve to **BYPASS** stops water from entering the cold water inlet of the water heater. Turn the valve to **BYPASS** when winterizing. For normal operation, turn valve so that handle points to **NORMAL FLOW**.

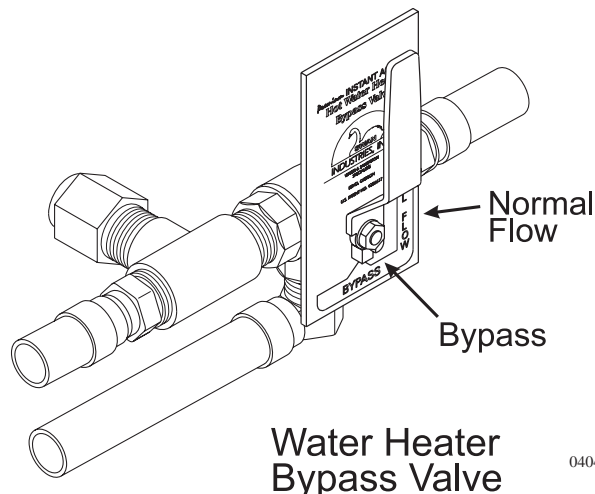

## Pressure Temperature Relief Valve

The water heater is equipped with a Pressure-Temperature relief valve. The water heater may discharge from the Pressure-Temperature relief valve during the heating cycle due to thermal expansion of water. The Pressure-Temperature relief valve is designed to open if the water temperature in the tank reaches 210° F (98.8° C), or if internal pressure reaches 150 psi. A small discharge is normal and is not necessarily a faulty valve. The water heater has an internal air pocket to reduce the possibility of dripping or weeping.

Eventually, the expansion of the water will absorb the air pocket. When this occurs, the air pocket will have to be replaced utilizing the following procedure.

**CAUTION:** Ensure the water heater tank is cool prior to making any check of the valve.

### Re-establishing the Air Pocket:

- Step 1: Turn OFF the water heater.
- Step 2: Shut OFF the incoming water supply.
- Step 3: Open the hot water faucet closest to the water heater.
- Step 4: Pull the handle of the relief valve until the flow of water stops.
- Step 5: Close the relief valve allowing it to snap shut. Close the hot faucet and turn ON the water supply.
- Step 6: Turn ON the water heater.

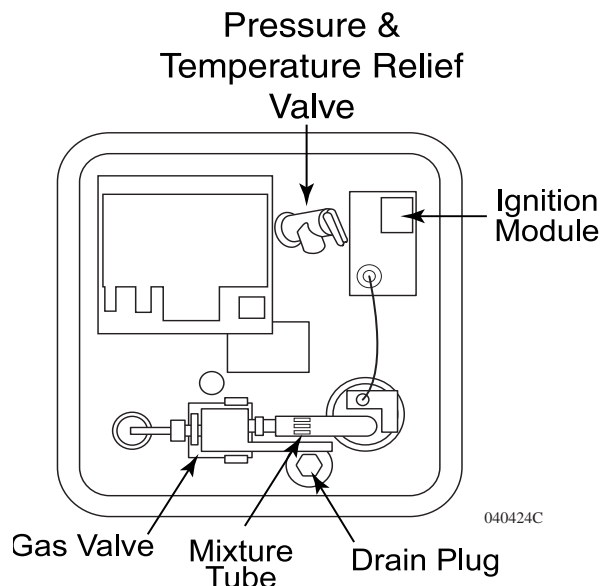

The air pocket is re-established and the process does not need to be repeated until the next discharge of water from the P & T valve. If the discharge does not stop, contact a qualified service center to evaluate the valve and make any required repairs.

Periodically check the outside service compartment and screen (in the door) for foreign material that can accumulate and prevent the flow of combustion and ventilating air.

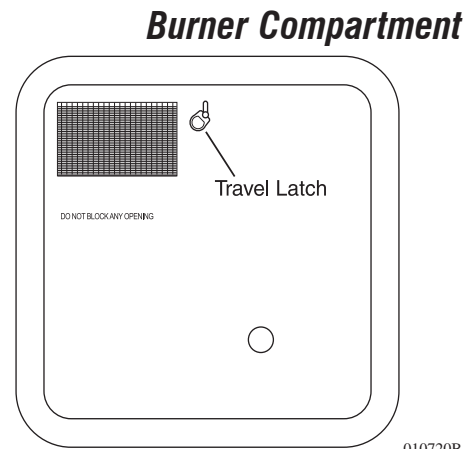

### **Tips**

- To conserve LP-Gas, turn off the water heater when not in use.
- When using the shower, conserve energy and hot water by shutting the shower water off when not in use.
- Use caution when hooked to anything less than 50 Amp shore service. When the water heater element is in operation it will use approximately 12 AC Amps. Appliances will need to be operated in sequence to avoid tripping a breaker.
- Water may drip occasionally from the Pressure - Temperature relief valve until the pressure has dropped. Avoid opening the P & T valve manually as collected minerals may cause the valve to leak continually. The valves can be purchased from most hardware stores.
- Operate the water heater using LP-Gas when hooked to 30 Amp shore power. This will reduce the likelihood of tripping the shore power breaker.

### **Draining & Storage**

If the motorhome is to be stored during the winter months, drain the water heater to prevent freeze damage.

1. Turn off electrical power to the water heater.
2. Shut off the primary LP-Gas valve.
3. Open low point drains.
4. Open both **HOT** and **COLD** on all faucets.
5. Remove water heater drain plug.
6. Turn the Bypass lever to **BYPASS**.

**NOTE:** Be sure to refill the water heater with water before resuming operation.

### Troubleshooting

- If water heater fails to light check the mixture tube for obstructions. Spiders may make nests in the burner tube. It is recommended to clean the burner tube with a brush and not compressed air. Compressed air may not fully remove the obstruction.
- If the indicator light on the switch does not light, and the water heater does not light, ensure the house power switch at the entry door is on or check for a blown fuse in the house distribution panel.
- If the water heater fails to operate after checking the fuses, the High Temperature safety limit switch may be tripped. Have a qualified technician inspect the water heater.

## WASHER-DRYER PREPARED

The washer-dryer “prep” package includes the following items:

- Two color coded water supply lines. A red line for hot; a blue line for cold.
- A 1½ in. water drain line with threaded cap, P-trap, and an automatic vent cap.
- A 120 Volt receptacle located in the compartment.

The washer drain line will either be connected to a grey or black holding tank. When the black (solid waste water) holding tank is used, the drain valve should be opened to drain the washer into the drain service. The black tank drain valve must be closed when washer is not in use to prevent the tank from becoming clogged.

When the grey (waste water) holding tank is used, the drain valve should be opened to drain the washer water into the drain service. The grey tank valve can be left open when the washer is not being used.

Before using the washer for the first time, determine which tank is being used:

- Empty all the holding tanks (see “Water Systems” section).
- Close all holding tank valves and run washer for one cycle. Washer will use between twelve and twenty gallons of water.
- Use the tank level monitor to determine which holding tank is being used. Drain the holding tank.

**NOTE:** Sidewall dryer vents are not part of the prep package. If a sidewall vent is to be installed, properly seal vent to sidewall.

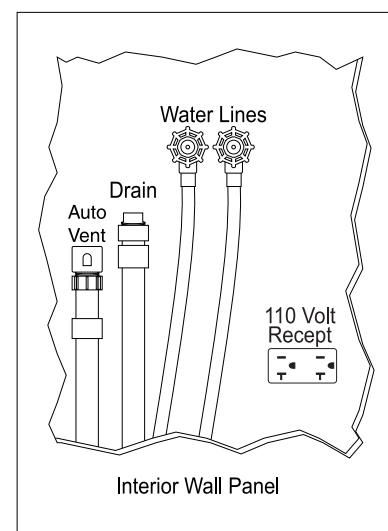

Location of specified parts may vary within wall panel depending on floor plan and model.

040495

If a washer-dryer is to be installed at a later date, follow all the manufacturer installation instructions. Listed here are further instructions which should be adhered to for safe and reliable operation:

- Do not connect the clothes dryer exhaust duct to any other duct, vent or chimney.
- Do not terminate the exhaust duct beneath the motorhome.
- Use proper length fastener when attaching exhaust vent to exterior sidewall. Stainless steel fasteners are best suited for this as they will not rust.
- If the cabinet or closet in which a washer-dryer is installed does not have vented louvered doors, the manufacturer's installation instructions may require installation of vented doors or vents to be installed in the doors. This is for sufficient circulation of drying.

## WASHER - DRYER (OPTIONAL)

The automatic washer-dryer has a capacity of up to 12 lbs. of dry clothing. It is front loading with an extra large door opening for easier access. Several wash and dry programs are available along with variable water temperature settings.

- The washer-dryer operates on 120 Volt AC from shore power or the generator.
- The washer-dryer will use approximately 12 to 20 gallons of water per wash cycle.

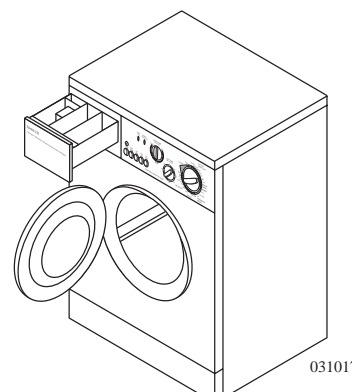

The washer drain line will either be connected to a grey or black holding tank.

When the black (solid waste water) holding tank is used, the drain valve should be opened to drain the washer water into the drain service. The black tank drain valve must be closed when washer is not being used to prevent the tank from becoming clogged.

When the grey (waste water) holding tank is used, the drain valve should be opened to drain the washer water into the drain service. The grey tank drain valve can be left open when the washer is not being used.

Before using the washer for the first time, determine which holding tank is being used:

- Empty all the holding tanks (see "Water Systems" section).
- Close all holding tank valves and run washer for one cycle. Washer will use between twelve and twenty gallons of water.
- Use the tank level monitor to determine which holding tank is being used. Drain the holding tank.

**INFO:** The washer-dryer has many features. Refer to the manufacturer's manual in the owner's information file for detailed operating instructions.

**WARNING:** Open a window or vent while operating the dryer. The washer-dryer can create negative air pressure inside the motorhome that can accumulate Carbon Monoxide or LP-Gas while operating fuel-burning appliances.

**CAUTION:** Do not use the washer-dryer while traveling. Suspension movement, combined with the weight of the drum while in the wash cycle, can damage the internal components of the washer-dryer.

Before using the washer after winter storage or a long period of non-use, it is a good idea to conduct this simple test procedure prior to loading the machine for use. This procedure will verify all the hardware and electronic components are functioning properly. Wipe the inside and outside with a damp cloth to remove any travel dust that has accumulated.

**NOTE:** Perform this test before putting the washer-dryer in use after the winter months. This will clear the water lines and drum of winterization antifreeze.

## Operation

### To Prepare the Washer/Dryer for Use:

- Make sure water supply lines are secure and fresh water valves are open.
- Hook to city water or turn on the water pump.
- Hook to shore power or start the generator.
- Connect the holding tank drain hose to the drain service and open the holding tank drain valve.

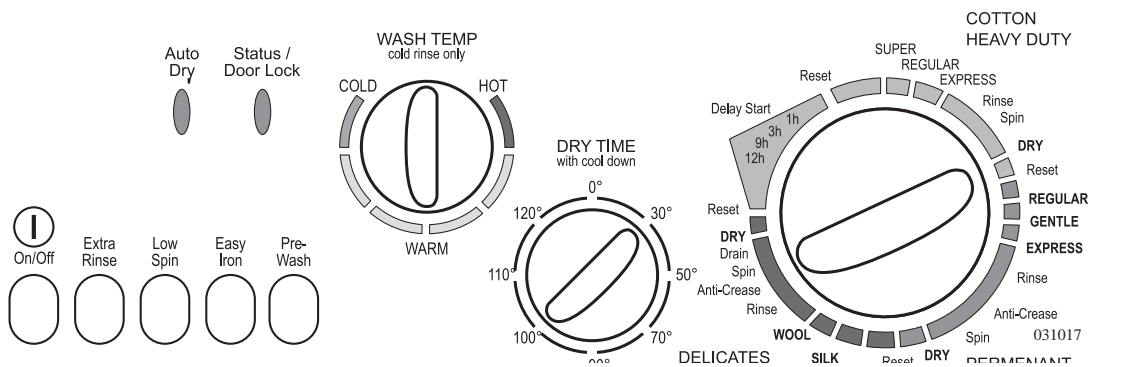

### To Conduct the Test Procedure:

1. Set the selector knob to **Reset**.
2. Set the **Dry Timer** knob to 30 minutes. Push the **On/Off** button to **On**. Wait five seconds. The **Auto Dry** light should be on and the **Status** light flashes fast then slow.
3. Set the selector knob to a wash cycle. Set **Wash Temp** knob to **Warm**. Water should be flowing into washer and drum should rotate both directions.
4. Set the selector knob to **Reset**. Wait five seconds.
5. Set the selector knob to **Spin**. Water should drain and drum rotation should speed up.
6. Set the selector knob to **Reset**. Wait five seconds.

7. Set the selector knob to **Dry**. Dryer fan should begin and drum should rotate both directions.
8. Set the selector knob to **Reset**. Wait five seconds.
9. Set the **Dry Time** knob to zero. The **Auto Dry** light should go off.
10. The door will unlock in two minutes or less. The **Status** light flashes fast then slow. The door should now open.
11. Push the **On/Off** button to **Out** (Off) position. The **Status** light should be off.
12. If applicable, close the holding tank drain valve.

**WARNING: Do not wash or dry articles that have previously been cleaned, washed, soaked or spotted with gasoline, dry cleaning solvents or other flammable or explosive substances. They give off vapors that could ignite or explode. Do not add gasoline, dry cleaning solvents or other flammable or explosive substances to the wash water. Do not use heat to dry articles containing foam rubber or similar textured, rubber-like materials.**

**To begin a wash load:**

- Sort and pre-treat clothes.
- Add the measured amount of detergent suggested by the package directions (maximum two tablespoons).
- Load the clothes loosely into the washer. Close the washer door.
- Turn the Wash Temperature knob to the desired temperature setting.
- Choose the desired washing cycle option using the Selector knob.
- Load wash tray with detergent.
- Turn the power ON.
- After the cycle is complete, wait two minutes for the door lock to release before attempting to open the door.
- If applicable, turn the power off and close the holding tank drain valve.

### Washer-Dryer Maintenance

Occasionally wipe the exterior cabinet of the washer-dryer with a damp cloth or sponge. Wipe dry with a soft cloth. Do not use polish on plastic trim. In areas of hard water, detergent can accumulate in the drum. Obtain a packaged water softener. Add quantity as specified by the manufacturer directly to the drum. Run the washer through a complete cycle using hot water. Repeat the process if necessary. Remove hard water deposits using only cleaners labeled as washer safe. Wipe the inside of the washer-dryer door with a soft cloth to remove any moisture. Periodically apply a thin coat of paste wax to the inner door, especially to the area that is immediately next to the door window. This will protect the door finish from laundry spills and discoloration.

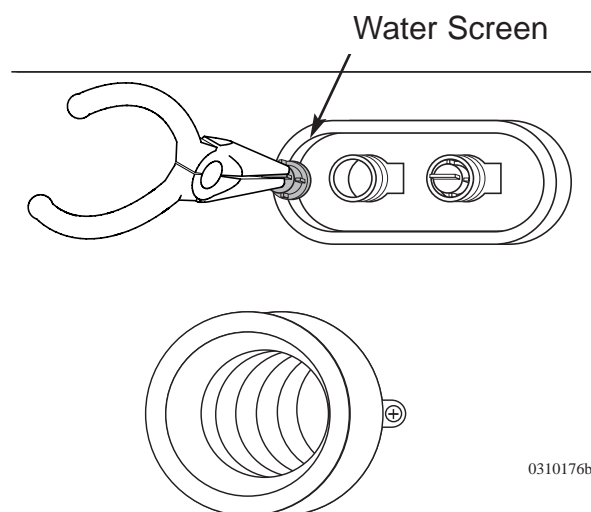

0310176b



If water flow to the washer-dryer is reduced, the Hot and Cold water inlet screens may be clogged. Remove water pressure and undo water lines at the back of the washer-dryer. Use tweezers or pliers to remove screens from fittings. Clean and install screens and water lines. Hook to city water or turn on the water pump. Check for water leaks before using the washer-dryer.

**NOTE: Should the washer-dryer need removal for service, care should be taken as the washer-dryer weighs approximately 170 lbs. Proper accommodations should be made to avoid risk of injury or damage to the cabinetry.**

---

### ***Winterizing the Washer-Dryer***

#### **To Winterize the Washer Dryer with Air Pressure:**

1. Hook an airline (regulated to 45 psi or less) to the water inlet of the motorhome.
2. Rotate Selector knob to a wash position with the Wash Temp setting on Warm. Press the power button to On. Air pressure will clear the Hot and Cold water lines.
3. After water lines are clear, rotate Selector knob to Spin. Allow the pump to drain the drum.
4. Set Selector knob to reset and Timer to zero. The door will unlock in two minutes or less. Open door and pour in  $\frac{1}{4}$  gallon of RV antifreeze.
5. Set Selector knob to Spin. The pump will prime with antifreeze. Set selector knob to Reset and turn the power off.

#### **To Winterize the Washer Dryer Using RV Antifreeze:**

Two methods of introducing antifreeze to the water system can be used. Add antifreeze directly to the water tank or use a separate container of antifreeze with water line hooked to the intake side of the water pump.

1. Turn on the Water Pump. Rotate Selector knob to a wash position with the Wash Temp setting on Warm. Press the power button to On. Allow antifreeze to enter the drum.
2. After water lines are filled with antifreeze, rotate Selector knob to Spin. Allow the pump to drain the drum.
3. Set Selector knob to reset and Timer to zero. The door will unlock in two minutes or less. Turn the power off.
4. Any remaining liquid should contain a sufficient amount of antifreeze to be protected from freezing.

**NOTE: After winter, perform a Test Procedure before washing or drying any laundry to make sure all antifreeze has purged.**







# Equipment

## Section 5

<b>EQUIPMENT - INTRODUCTION</b> .....	<b>173</b>	<b>STORAGE - UNDER BED</b> .....	<b>197</b>
<b>ENTRY STEP</b> .....	<b>173</b>	<b>DINETTE</b> .....	<b>197</b>
Operation .....	173	Bed Conversion (Opt) .....	197
Maintenance & Lubrication .....	174	Dinette Bed Conversion (Opt).....	198
<b>STEPWELL COVER</b> .....	<b>175</b>	<b>FLIP UP TABLE (OPT)</b> .....	<b>198</b>
<b>ENTRY DOOR</b> .....	<b>175</b>	<b>STORAGE BAY SLIDE OUT TRAY (OPT)</b> .....	<b>198</b>
Screen Door Maintenance.....	176	<b>ENTERTAINMENT SYSTEMS</b> .....	<b>199</b>
<b>SLIDE-OUT OPERATION</b> .....	<b>176</b>	Hook-ups - TV Cable, Computer & Telephone .....	199
Main Room Slide-outs .....	177	Television (Front) w/Lock-out Feature.....	199
Bedroom Slide-out.....	179	Television Antenna.....	200
Manual Override - Bedroom Slide-out .....	181	Video Cassette Recorder (VCR) (Opt) .....	201
Slide-out Cover.....	182	DVD Player (Opt) .....	202
<b>AWNINGS</b> .....	<b>182</b>	Video Selector Box .....	202
Front Door (Opt) .....	182	Satellite System - Prewire .....	204
Window Awning (Opt) .....	183	<b>SATELLITE SYSTEM (OPT)</b> .....	<b>204</b>
Awning - Patio.....	183	Integrated Receiver Decoder .....	204
Patio Awning - Eclipse (Opt) .....	187	Operation .....	204
Awning Care & Maintenance.....	187	Maintenance.....	206
<b>REAR LADDER</b> .....	<b>188</b>	<b>RADIO - DASH</b> .....	<b>206</b>
<b>FANS</b> .....	<b>189</b>	Citizens Band Radio - Prewire.....	206
Attic Exhaust Fan.....	189	<b>EXTERIOR ENTERTAINMENT CENTER (OPT)</b> .....	<b>20</b>
Bathroom Fan.....	190		
Rain Sensor Exhaust Fan (Opt) .....	190		
Tips.....	192		
<b>POWER SUNVISOR (OPT)</b> .....	<b>192</b>		
<b>SEAT CONTROLS</b> .....	<b>193</b>		
Swivel Seats.....	193		
<b>SOFA</b> .....	<b>194</b>		
Hide-A-Bed Conversion (Opt) .....	194		
Air Mattress (Opt).....	195		
Wonder Bed Conversion (Opt) .....	196		
Electric Sofa Bed Conversion (Opt) .....	196		



## EQUIPMENT - INTRODUCTION

This section covers the basic operation and care of various types of equipment found in the motorhome, most of which are provided for entertainment and comfort. More detailed information about specific equipment may be found in that particular manufacturer's manual. Optional equipment will also be discussed in this section which may not apply to all motorhomes.

**INFORMATION: Detailed information with CAUTION or WARNING instructions for the various electronics, other than what is provided in this section, can be found in the manufacturer's manual.**

### ENTRY STEP - Operation

The entry step features amber lighting under the step, automatic retraction with the ignition key in the **RUN** position and a last out feature. Located just inside the entry door is the step switch. The uppermost step has a **storage compartment** with removable tray. The area can be utilized to store frequently used items such as, gloves (for refueling), tire pressure gauge, flashlight or outside slippers.

#### Operating the Entry Step:

1. With the entrance door open, turn the step switch on.
2. Close the door. The step should retract and lock in the **UP** position. The step light will remain on.
3. Open the door. The step should extend and lock in the **DOWN** position with the under step light on. The step will retract when the door is closed.
4. The step is equipped with a power switch. When the switch is turned off, the step should remain in the extended position with the door closed and the light off. Close the door and turn on the ignition switch. The step will retract for travel.
5. With the power switch off, the step extended, the entrance door closed and the ignition turned on, the ignition override system will go into effect and the step will automatically retract.
6. Turn the ignition off and open the door. The step will extend and lock in the **DOWN** position. This is the "last out" feature. When the ignition is on the step will always activate with the door movement, regardless of the power switch position.

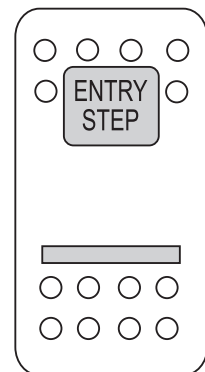

080433

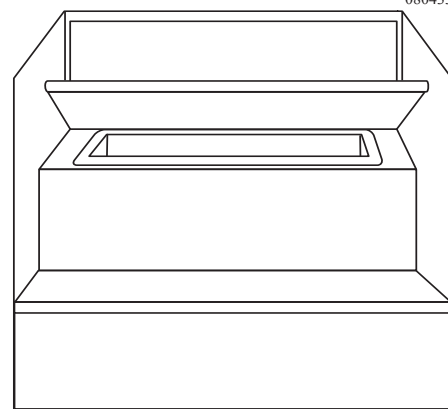

090344

**NOTE: Turn off the power switch to the step when dry camping to avoid draining the chassis battery. If dry camping it is important to notice if the bar light indicator is illuminated, that means all the step circuits are active and drawing current from the chassis battery.**

**CAUTION: High curbs can impede step operation.**

**If the step fails to operate:**

- Verify that the step switch is **ON**.
- Check the main power supply for the step, a 25 Amp fuse is located in the front distribution panel.
- A magnetic door jam switch is used to control step operation. Use a separate magnet to apply a “trigger” to the door jam switch. Rotate test magnet to align polarity field.

**WARNING: If the motorhome is driven with the step in the extended position there is the possibility of causing major damage to both the step and the motorhome.**

---

***Maintenance & Lubrication***

Clean all mud, salt and road grime from the step before lubricating. Lubricate all moving parts (rivet points, and the cam assembly) every 30 days with a good quality silicon based grease.

**NOTE: WD-40 is not recommended as it has a tendency to evaporate and dry the mating surfaces which leaves them vulnerable to the elements.**

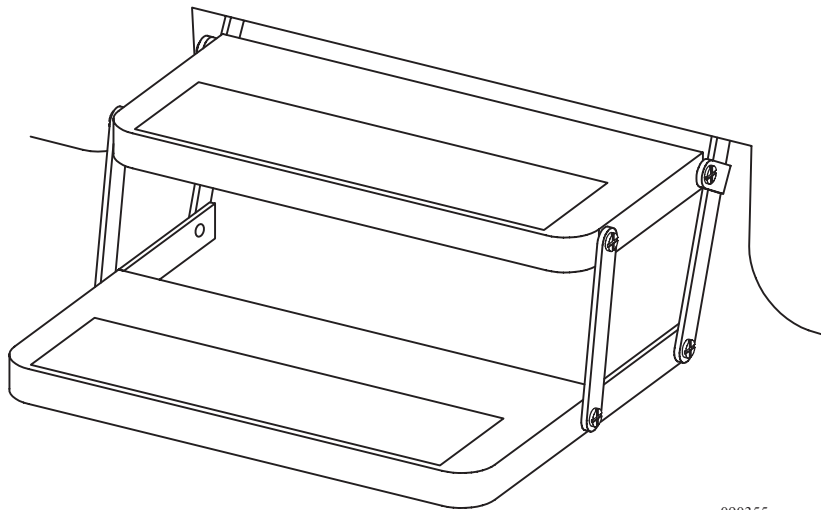

090355

---

---

## STEPWELL COVER

The stepwell cover operates by 12 Volt DC house power.

### To Operate the Stepwell Cover:

1. Turn on the battery cut-off switch.
2. Press the Step Cover switch to the desired direction. Release the switch to stop movement.

**CAUTION:** When operating the stepwell cover, be sure there are no pets, shoes or other obstructions in the stepwell area. Do not operate the stepwell cover while standing in the stepwell area.

---

## ENTRY DOOR

The entry door is adjusted at the factory and tested for all operations. The door incorporates three separate seals to eliminate wind noise during travel. The door uses two separate locks for safety and security. One locking system is the door handle and the other is a dead bolt. The door handle incorporates a primary and secondary latching system. This is used to ensure secure and safe latching. There are adjustments which can be made to help maintain entry door performance.

### Adjusting the Entry Door Latch:

- Determine which bolt needs adjustment.
- Slowly close the entry door observing the latch and strike bolt alignment. Do not attempt to latch if the alignment is off. If the alignment is correct, allow the latch to catch in the first (primary) position only.
- The latch should move to the second position with only slight pressure applied to the entry door. Upper and lower latches should be evenly timed. Press on the entry door to check for further movement of the door.
- The entry handle should operate with little effort to open the entry door. Excessive pressure indicates the bolts are set too far back.
- With a 5/8" inch box wrench or socket, loosen the movable strike bolt. Make all adjustments in small increments. Tighten the bolt firmly after making adjustments. The bolts should have slight up and down movement for vibration control in travel.
- Test the operation of the dead bolt lock to ensure proper functions.
- Apply silicone weekly to the entry door rubber gaskets to prevent squeaking while the motorhome is traveling. Use a one inch sponge paint brush, sprayed with silicone for easy application.

**CAUTION:** When operating the entry door ensure the dead bolt latch is fully in the unlock position prior to closing the entry door. Failure to do so can result in damage to the dead bolt and/or entry door.

## Screen Door Maintenance

### Changing Screen Door Glass:

- The screen slider is Plexiglas, the slider can be bowed for removal and replacement.
- Replace with new Plexiglas and reverse the procedure.

### Adjusting the Screen Door:

- Loosen the chrome bolts on the hinge side of the screen door; four on the top and four on the bottom.
- The steel hinge has slots to allow up and down movement.
- Four Philip head screws are on the top hinge, and four on the bottom hinge, to adjust the screen door to properly fit to the entry door. The hinge should fit tightly to the trim of the door when the screen door is latched to the door and the door is open.

### Removable Screen:

- The top half of the screen door is removable. This allows clear viewing through the entry door glass while traveling.
- To remove the top half of the screen door for travel, rotate clips and remove the screen.
- To store the screen for travel, use the clips provided on the bottom half of the screen door.

---

## SLIDE OUT OPERATION

The main slide-out room operates by an electric switch which controls an electric motor. Slide-out room operation uses many safety features preventing mechanical damage or physical harm. The slide-out room(s) will not operate until the following safety requirements are met.

- Ignition switch must be in OFF position.
- Parking brake must be applied.
- Transmission must be in neutral or park.

The design of the slide-out system requires very little maintenance. To ensure long life of the slide-out system, follow these simple guidelines:

- **Inspect** the roof of the slide-out for debris such as pine needles, dirt, leaves, sticks, etc. Any debris left on the top may cause damage to the seals when being retracted. If debris is present wash with soap and water, then rinse.
- When the room is out visually **inspect** the wipe seal. The seal should be clean and free of dirt or other foreign material. **Inspect** for torn seals.
- In the event the slide-out room leaks, fully retract it. If necessary, tape the exterior opening closed with duct tape until repairs to the motorhome can be completed.
- Open a window or a vent to equalize pressure during slide-out operation.



**NOTE:** Slide-out adjustment is not warrantable after 12 months. Do not use any petroleum-based products on the slide-out seal. Petroleum based products can damage the paint and will cause premature aging of the rubber seal.

**WARNING:** Move the cab seat(s) forward before activating the front slide-out room(s). Damage to the upholstery can occur. The outside area must be clear of any obstructions restricting slide-out room operation. Ensure there is five or more feet of clear space outside the slide-out room prior to extending or damage can occur. When retracting the slide-out room, ensure there is sufficient clearance inside the motorhome. Never move the motorhome with any slide-out room extended.

**CAUTION:** Continuous operation of the slide-out room can drain the batteries and damage the motor from overheating.

### ***Main Room Slide-outs***

#### **To Extend the Main Slide-out Room(s):**

- Move the cab seat(s) forward.
- Confirm that there is at least five feet of clearance outside the motorhome for the slide-out room to extend.
- Be sure the bay doors under the slide-out room are closed.
- Ensure the ignition key is in the **OFF** position.
- The park brake must be applied.
- The house batteries are fully charged.
- Be sure all people, pets and objects are clear of slide-out room path.
- Remove the lock bars.
- The control switch for the slide-out room is on the system monitor panel.
- Press and hold the front slide-out room switch in the **OUT** position. The slide-out room will slowly move to the **OUT** position. Release the switch to stop room movement. To continue the room movement, push and hold the switch in.
- Release the slide-out switch when the room is fully extended (a change in motor sound indicates extension). The slide-out drive motor will not stop automatically; the switch must be released.
- If equipped, extend additional slide-out rooms.

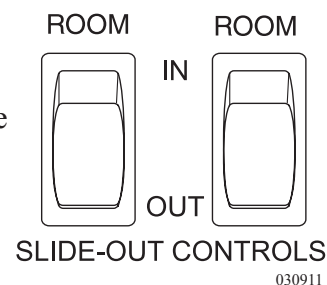

**NOTE:** Perform the slide-out room operation with the air suspension system full. Extensive damage could occur to the slide-out room and awning when extending the slide-out room in snow, sleet, ice or freezing rain. In such conditions, if the slide-out room is extended, clear the awning and ensure free movement prior to operating the slide-out room.

**CAUTION:** Dirt and grit trapped under the slide-out room could result in damage to the floor. Continuous operation of the slide-out could cause a drain on the house batteries and damage to the slide-out motor from overheating.

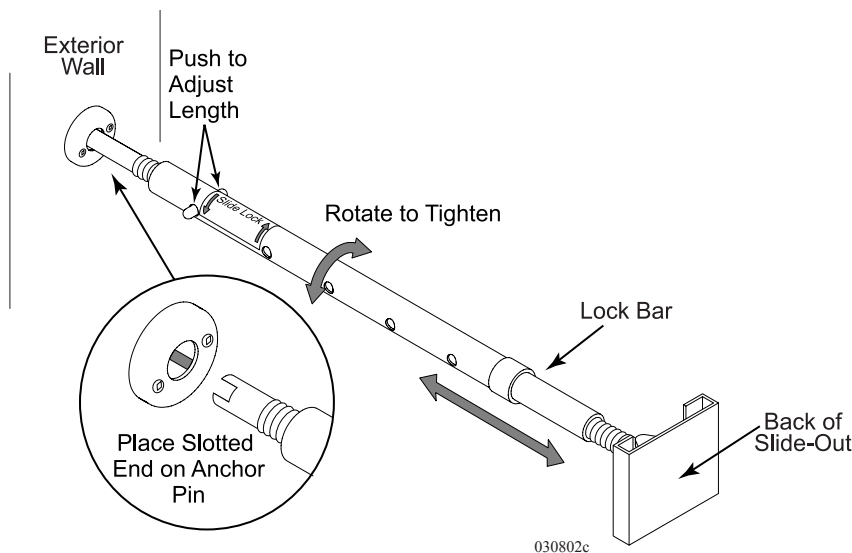

**To Retract the Main Slide-out Room(s):**

- Check for sufficient clearance inside the motorhome before retracting the slide-out room.
- Clean the floor, if applicable, to ensure there is no dirt or grit that could result in floor damage during operation.
- Move the cab seat(s) forward.
- Inspect the exterior to ensure there are no sags in the awning material.
- Remove any debris from the top of the slide-out room.
- Be sure the bay doors under the slide-out room are closed.
- Prior to retracting the slide-out room, start the motorhome. Allow the air bags to fully inflate to normal travel height.
- Retract the leveling jacks prior to operating the slide-out.
- Turn the ignition switch **OFF**. The slide-out room will not operate with the engine running.
- The house batteries should be fully charged.
- The park brake must be applied.
- Ensure all people, pets and objects are clear of slide-out room path.
- Press and hold the switch in the **IN** position. The slide-out room will move slowly in. To stop the slide-out room, release the switch. To continue the room movement, push and hold the switch in.

**NOTE:** Be sure you have sufficient clearance on the inside of the motorhome (cab seat(s), etc.) before you retract the slide-out room. Ensure the floor is clean before you retract the slide-out room. Trapped dirt or grit under the slide-out room can scratch the floor surface. Never move the motorhome with the slide-out room extended.

**CAUTION:** Rain water can pool on the slide-out awning. The added weight will cause the awning to sag. Upon retracting the room, material can become caught in between the top of slide room and the opening in the motorhome. It will be necessary to retract the room in small increments allowing the water time to run off.

**If the Slide Room Fails to Operate:** Check the fuse and auto-reset circuit breaker on the slide-out relay module located in the roadside battery compartment. If the fuses and circuit breakers test okay, it will be necessary to call and obtain mechanical assistance to correct the problem.

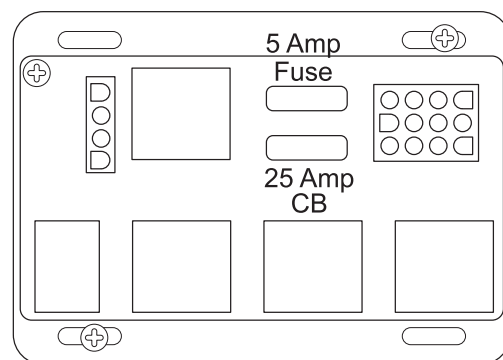

080429c

### Bedroom Slide-out

#### To Extend the Bedroom Slide-out Room(s):

- Confirm that there is at least five feet of clearance outside the motorhome for the slide-out room to extend.
- Ensure the ignition key is in the **OFF** position.
- The house batteries are fully charged.
- The battery cut-off switch must be in the **ON** position. Depending on the floor plan, the switch is either on the monitor panel, or in the bedroom wall.
- Ensure all people, pets and objects are clear of the slide-out room path.
- Press and hold the rear slide-out room switch in the **OUT** position. The slide-out room will slowly move to the **OUT** position. Release the switch to stop room movement. To continue the room movement, push and hold the switch in.
- Release the slide-out switch when the room is fully extended (a change in motor sound indicates extension). The slide-out drive motor will stop automatically.
- Level the motorhome with the leveling system.

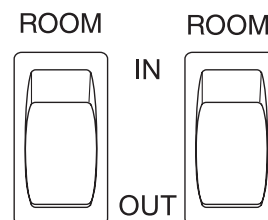

SLIDE-OUT CONTROLS

030911

**WARNING:** Firmly latch all cabinet doors adjacent to the bedroom slide-out before extending or retracting the room. Damage to doors or fascia can occur.

**CAUTION:** Dirt and grit trapped under the slide could result in damage to the floor. Continuous operation of the slide-out could cause a drain on the house batteries and damage to the motor from overheating.

**NOTE:** Do not leave the slide-out in the extended position during severe weather. Conditions such as high winds or heavy rain may cause damage.

**NOTE:** Perform the slide-out room operation with the air suspension system full. Extensive damage could occur to the slide-out room and awning when extending the slide-out room in snow, sleet, ice or freezing rain conditions. In such conditions, if the slide-out room is extended, clear the awning and ensure free movement prior to operating the slide-out room.

**To Retract the Bedroom Slide-out Room(s):**

- Check for sufficient clearance inside the motorhome before retracting the slide-out room.
- Clean the floor, if applicable, to ensure there is no dirt or grit that could result in floor damage during slide-out retraction.
- Remove any debris from the top of the slide-out room.
- Prior to retracting the slide-out room, start the motorhome. Allow the air bags to fully inflate to normal travel height.
- Retract the leveling system or prepare the air leveling system for travel prior to operating the slide-out.
- Turn the ignition switch **OFF**. **The slide-out room will not operate with the engine running.**
- The house batteries are fully charged.
- The battery cut-off switch must be in the **ON** position.
- Locate the control switch for the slide-out, usually located on the monitor panel, or on the bedroom wall.
- Clear all people, pets and objects from the slide-out room path.
- Press and hold the switch in the **IN** position. The slide-out room will move slowly **IN**. To stop the slide-out room before the room reaches the **IN** position, release the switch. To continue the room movement, push and hold the switch in. The motor will automatically stop when the slide-out room is fully retracted.
- Release the switch.
- Rain water can pool on the slide-out awning. Added weight will cause the awning to sag. Upon retracting the room, the material can catch between the top of the slide room and the opening in the motorhome. It will be necessary to retract the room in small increments, allowing the water time to run off.

**CAUTION: Continuous operation of the slide-out room can drain the battery and damage the slide-out motor from overheating. Never move the motorhome without having the slide-out room retracted.**

## Manual Override - Bedroom Slide-out

If the slide-out room does not respond from the switch, check that all the safety features are in place.

- The ignition key is **OFF**.
- The battery cut-off switch is **ON**.
- The house batteries are fully charged.

**If the Slide Room Fails to Operate:** Check the fuse and auto-reset circuit breaker on the slide-out relay module located adjacent to the inverter. If the fuses and circuit breakers test okay, it will be necessary to call and obtain mechanical assistance to correct the problem.

**WARNING: Do not work on the slide-out system unless the battery is disconnected. Make sure the floor is clean before retracting the slide-out room.**

After the previous items have been checked and the room still does not move when the slide-out switch is pressed, follow these simple steps to manually override the slide-out room:

### Manual Override for Bedroom Slide-out:

1. Lift up the mattress and unscrew baseboard to gain access to the slide-out cover board and mechanism.
2. Remove 12 Volt DC from the motor by disconnecting the plug from the slide-out motor to the power supply.
3. The drive mechanism has a sliding coupling to engage and disengage the drive motor. Turn the large hex nut clockwise to unlock the drive motor.
4. The slide-out then can be pushed back.
5. Once the slide room has been manually retracted, turn the large hex nut counterclockwise to lock the room in place.
6. Take the motorhome to an authorized dealer for service.

**NOTE: The slide out room is heavy and may require several persons to push it into the retracted position.**

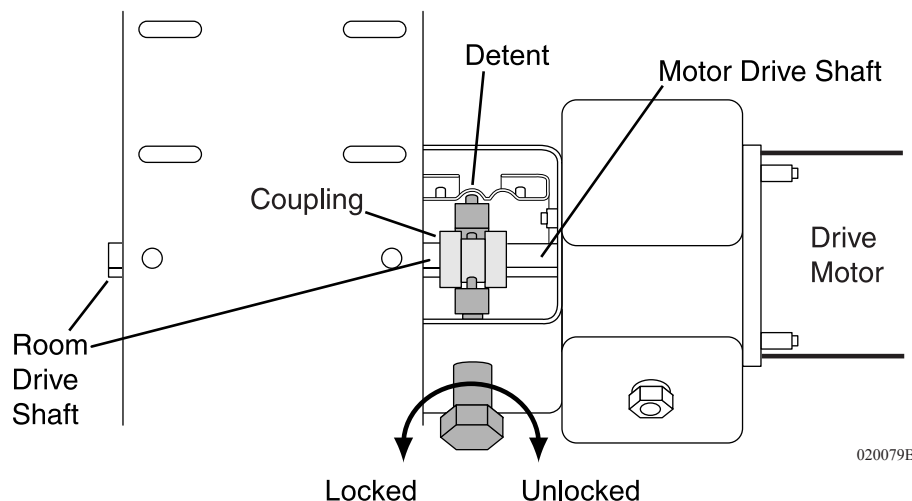

## Slide-out Cover

The slide-out cover is automatic. When the slide-out moves in or out, the cover reacts to the slide-out direction. A fixed edge of the slide-out cover is installed into an awning rail, mounted just above the slide-out. A spring-loaded roller with special brackets mounts to the slide-out. In a hard rain, the cover helps prevent water from penetrating the seal of the slide-out.

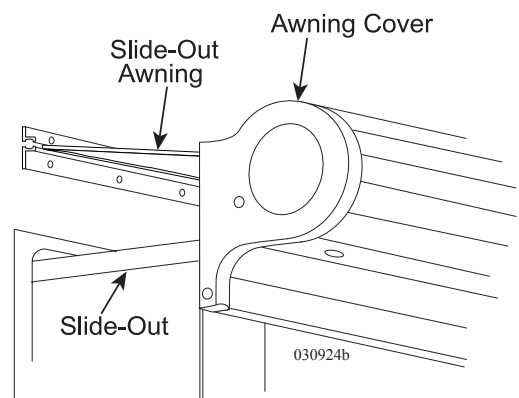

The slide-out cover will extend automatically attaining full coverage when the slide-out achieves maximum extension.

**NOTE: Water may pool on top of the extended cover. As the slide-out is retracted, the water is removed when the cover retracts. Retract room slowly. Pause three or four times to allow any accumulated water a chance to run off.**

The slide-out cover retracts automatically and rolls up to the travel position when the slide-out is completely closed.

**NOTE: When retracting the slide-out, stop the room about halfway. Confirm that the fabric is rolling properly before fully retracting the slide-out.**

## AWNINGS - Front Door (Optional)

### To Extend the Awning:

- Hook the pull strap loop with awning pull rod.
- Pull strap until awning is at full extension. With free hand, lever out inner arms.
- Mate the slot of inner arm with hook on side of the motorhome. Repeat procedure for other arm.
- Release strap slowly ensuring inner arms are secure.

### To Retract the Awning:

- Pull down on pull strap with a firm grip until tension is off the inner arms. Fold inner arms and attach them to the velcro.
- Carefully allow material to wind onto awning roll tube while holding strap in a neutral position. This will allow material to roll up evenly.
- Awning end caps should be against the rubber bumpers. If one end cap is off, pull down on awning pull strap while holding strap slightly to opposite side, allowing awning to roll back up into position.

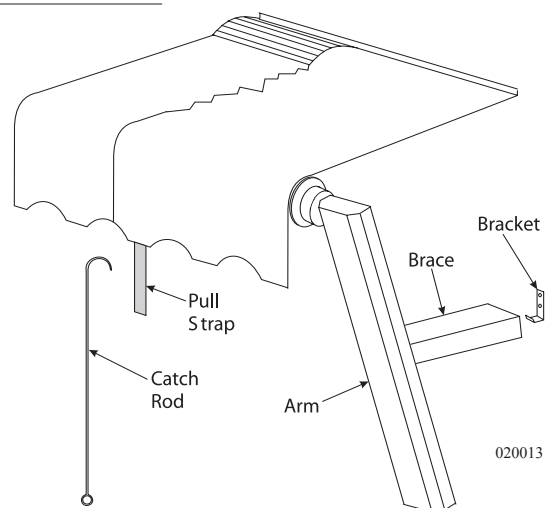

**CAUTION: When the awning is at full extension do not allow the awning to snap back into the retracted position. Personal injury or damage to the awning or motorhome may occur.**

## Window Awning (Optional)

### To Extend Awning:

- Hook loop of pull strap with catch rod and pull awning, reel assembly and side arms to extend fully away from motorhome.
- Hook pull strap on side strap hook, remove catch rod from pull strap and store.

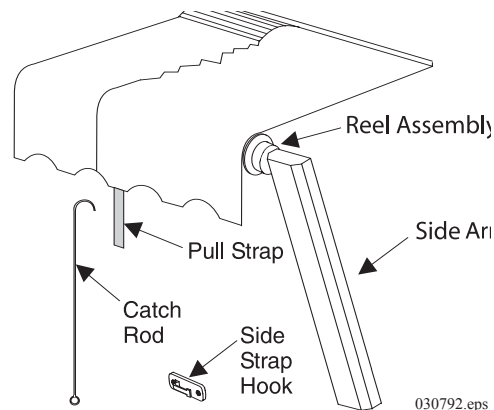

### To Retract Awning:

- Hook catch rod on pull strap, remove pull strap from side strap hook and slowly allow awning to retract.
- Remove catch rod from pull strap and store

## Awning - Patio

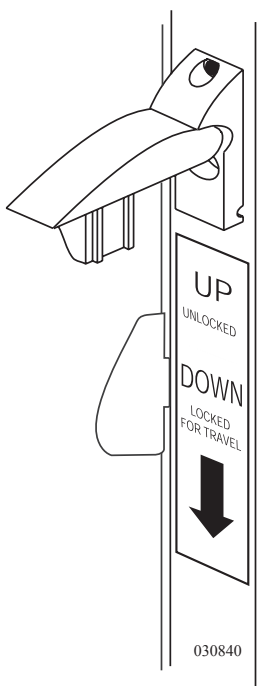
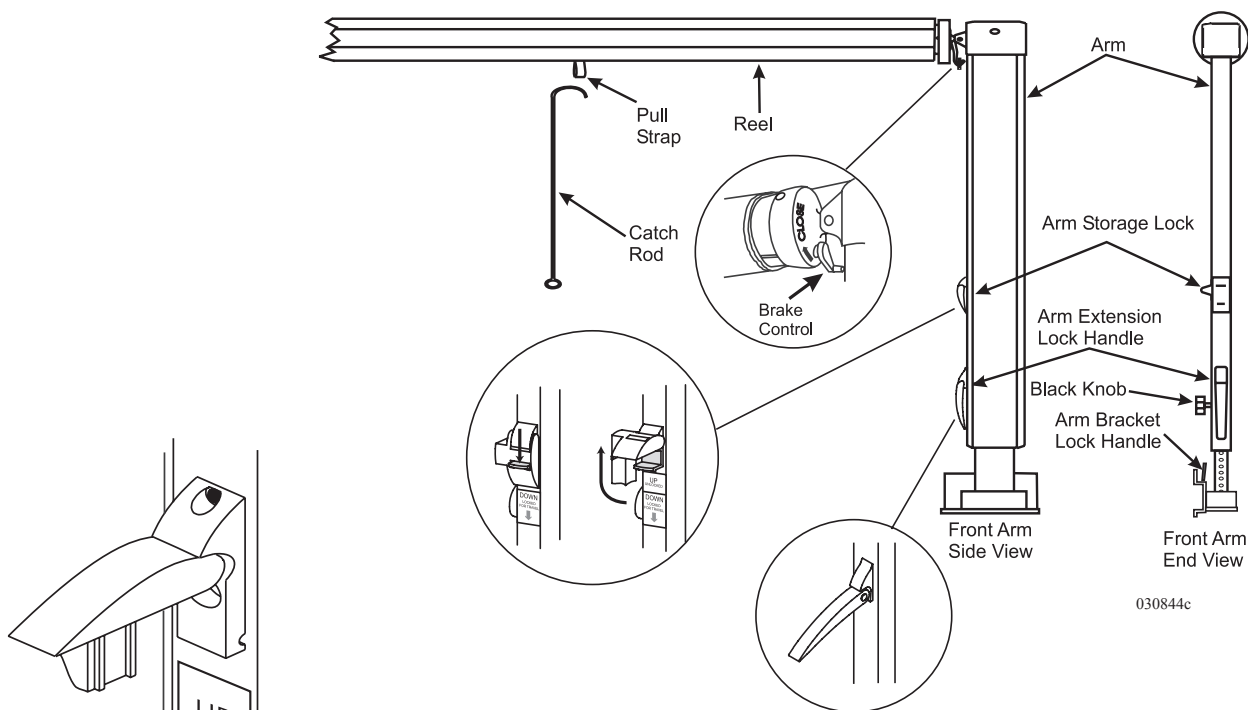

Lower Brake Control

### To Unlock the Awning:

Start with either awning leg and repeat the following steps for each leg.

1. Loosen the black locking knob located on the backside of the awning leg (only about six turns are needed). This will allow the support brace to move freely.
2. Unlock the travel lock by using one hand to squeeze inner and outer arm to remove tension from storage lock. Push up on tab and swing lock away.
3. Move the brake control (front leg only) to the up/unlock position.

**To Extend the Patio Awning:**

1. Locate the awning pull rod.
2. Locate the loop of the pull strap and hook it with the awning pull rod. Draw the awning away from the motorhome to the desired extension.

**WARNING:** Always use the pull strap for extending and retracting awning. Never retract awning while holding onto the awning arm. Hands or fingers caught between the awning arm channel and brace channel during awning retraction may result in serious injury.

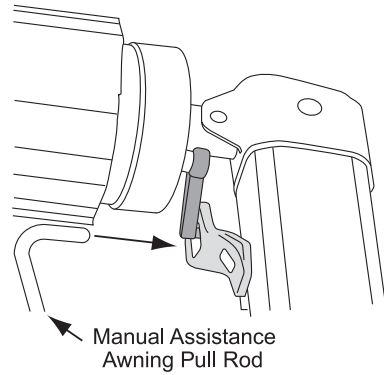

030841c

3. Slide the inner bracing rafters to the top of each arm ensuring the bracing is locked in place. Tighten the black locking knob.

**NOTE:** Ensure the locking tab on the support brace is latched through in the hole in the end cap.

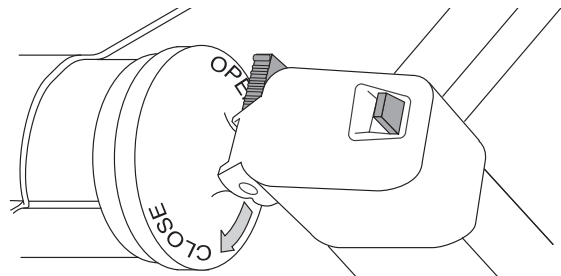

030841b

4. If equipped with Canopy Clamps, fasten the clamps at this time.
5. Using the arm extension lock handle, the awning can be hoisted upwards for additional clearance. Grasp upper arm with one hand and lift slightly upward. While lifting upward, push in on the release lever located on the lower portion of the upper arm. Lift front of awning to the desired height. Support the weight of the awning with one hand while relaxing release lever and allow the engaging pin to set into a hole in the lower arm. Go to the other awning arm and do the same. Ensure the awning is straight.
6. Slide the center pull strap to one end of the awning and store it by wrapping the strap around the awning leg.

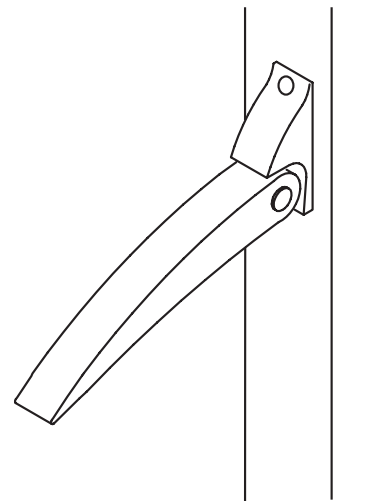

030841e



**To Retract the Patio Awning:**

1. Loosen the strap from the awning leg if it has been stored there.
2. Support the weight of the awning with one hand while opening the extension lock handle and lower the awning until the arms rest on the lower stop bolt. Loosen the two black locking knobs enough to allow the support brace to travel freely.
3. If equipped with Canopy Clamps, remove and store the clamps at this time.
4. Release the locking tab on the end cap of the awning leg and slide the inner support brace to down the awning leg to the stop bolt. Repeat for opposite side.
5. While pulling down slightly on the pull strap, slide the brake control down located on the front awning leg.
6. Keeping downward pressure applied, slide the pull strap to the center of the awning while holding on to the strap.
7. Place the hook end of awning rod into pull strap loop to assist in retracting the awning. Make sure pull wand does not slip out of pull strap loop, allow the awning to roll up to the stored position.
8. Store the awning rod until it is needed again.
9. Verify that the brake control is in the locked or closed position. Snap the arm storage locks into the down position and tighten black locking knobs.

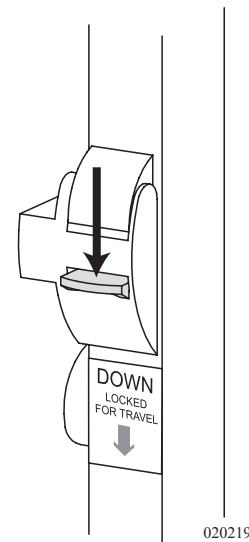

**Rain Release Setting:** After the awning has been extended, choose the rain release position to prevent water build up on the awning. To position the awning in the rain release setting, lower one arm of the awning and leave the other arm in the normal position. This will create enough of a slope for adequate water run off.

**NOTE:** Water can quickly accumulate on the canvas during storm activity and damage the awning or motorhome. Storm related damage is not covered under warranty.

**Using the Carport Feature:** (Not available with Carefree One Touch Awnings.)

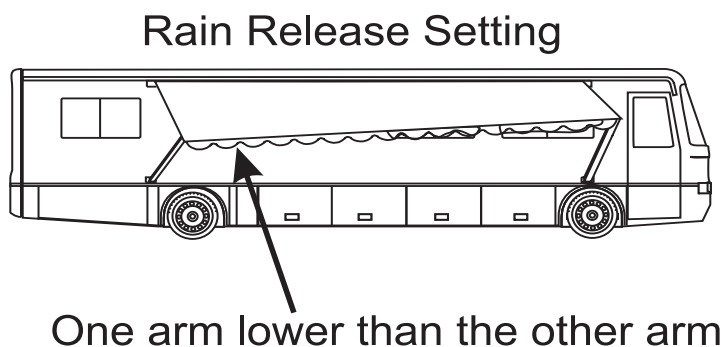

**Using the Carport Feature:**

(Not available with Carefree One Touch Awnings.)

1. Unlock and extend the awning as described under "To Unlock the Awning" and "To Extend Awning."
2. Unlatch the bottom of the rear arm by pushing in on the lock handle on the arm bracket. Swing the arm away from the motorhome to an upright position.
3. Drive the stakes through the bottom holes in the arm.
4. Raise the rear arm extension lock handle all the way up or to the desired height and lower the lock handle to lock the arms in place.
5. Repeat instructions 2 through 4 for the front arm.

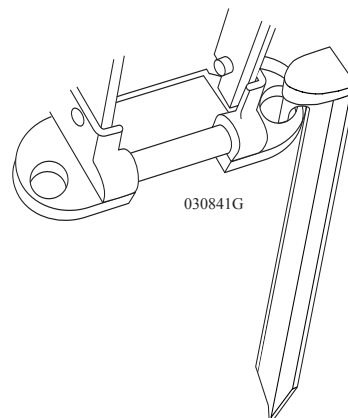
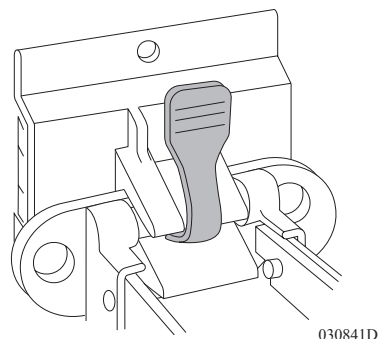

**NOTE:** To move the awning out of the carport position reverse the above steps.

**Securing the Awning for Travel:**

Before traveling, check the following:

1. The awning is fully retracted against the sides of the motorhome.
2. The black locking knobs are tightened.
3. The brake control is in the full down (locked) position, and no red warning is showing.
4. The storage locks are down and in the locked position.
5. The bottom of the front and rear arms is latched properly into the bottom brackets.
6. The awning pull rod is stored away.

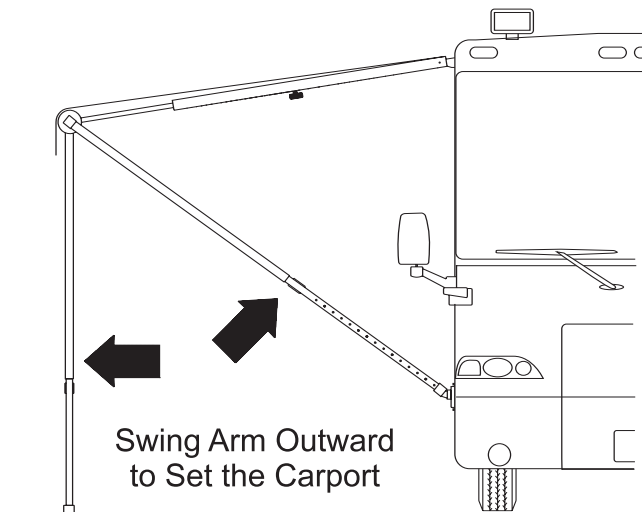

**Patio Awning - Eclipse (Optional)**

The awning requires 10' of lateral side clearance.

- Turn the power button to ON.
- Push and hold the button to extend the awning. Release the button at any time for partial extension.
- Push the button and hold to retract awning.
- External control switch is located on the front outside arm track. Operation is the same as the inside control panel.

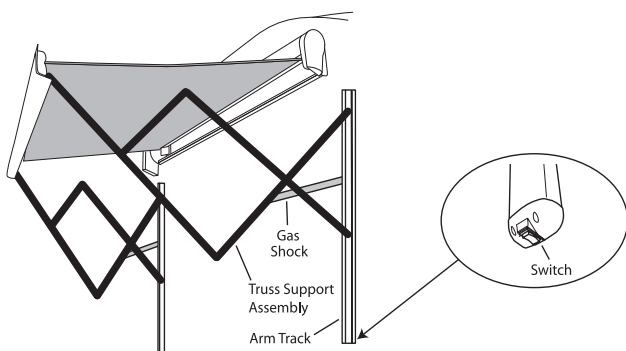

030581d

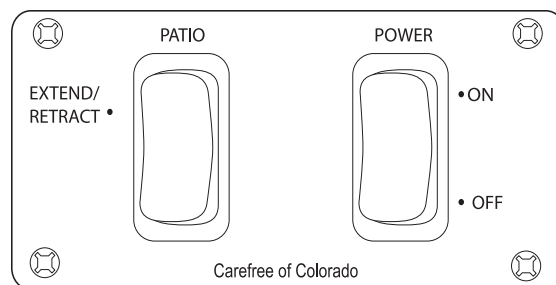

030851d

**Awning Care & Maintenance**

Mildew will not form on the awning material itself, but it may form on the dust accumulated on the canopy. A quality vinyl cleaner, such as Carefree Awning Magic, will help keep your awning looking new. Be sure to follow the instructions on the container.

**NOTE: Allow the awning material to thoroughly dry before rolling the awning up. Metal surfaces should be cleaned with soapy water and thoroughly rinsed.**

**Care of Awning Acrylic Fabric:** The acrylic fabric should be cleaned regularly before substances such as dirt, leaves, etc., are allowed to accumulate on, and become embedded in, the fabric. The fabric can be cleaned without being removed from the awning. Simply brush off any loose dirt, leaves, etc. Hose down and clean with a cloth and mild soap. **Do not use detergents.** Allow to air dry, preferably on a warm sunny day. Should you have to retract the awning when the fabric is wet, it should be extended at the first opportunity to finish air drying.

Avoid leaving the awning partially extended during rainy conditions. The awning is at the strongest setting when fully extended.

**Cleaning and Maintenance:**

- **Washing:** On a monthly basis, loosen hardened dirt and remove dust from the awning with a dry, medium bristle brush. Thoroughly rinse both the top and bottom with a hose. This process can be made easier with awning maintenance products. Saturate the fabric with the solution and leave it on for 15-20 minutes. Wash both sides of the awning using an awning brush. If necessary, reapply the solution to keep fabric saturated. Rinse the awning thoroughly. Repeat, if necessary, until most of the stains disappear.
- **Water Leaks:** If leaking occurs after washing, it generally results from insufficient rinsing. If water drips through the needle holes in the stitching use a commercial seam sealer which is available in canvas and trailer supply stores. Paraffin wax may also be applied to the top of the seams. As the awning “weathers” these holes will normally seal themselves.

It is normal for slight leakage to occur through the fabric where water is allowed to accumulate or pocket on the fabric. See “**Storm Precautions**” for information on the awning settings for proper water drainage. Sometimes soap or chemical residue, such as from active agents in insect fog or sprays, can “wet” the fabric so that it appears unable to repel water. Rinse the fabric thoroughly and test to see if it is water repellent after it dries. If leakage continues after repeating the washing and thoroughly rinsing, please contact *Carefree of Colorado* concerning further maintenance.

**Storm Precautions:** The warranty does not cover damage caused by acts of nature; therefore, steps should be taken to prevent damage from occurring due to wind, rain or storms. If you are leaving or retiring for the night, close the awning. This takes only a few seconds and it gives the best protection for the awning. If unable to close the awning, lower both ends of it as far as you can. This will create a sufficient slope for water run-off. One end may be lowered to sufficiently divert the water, if the awning is being monitored.

**CAUTION: Water can quickly accumulate on the canvas during storm activity and damage the awning or motorhome. Storm related damage is not covered under warranty.**

---

## **REAR LADDER**

The rear ladder allows access to the roof. Care should be used when climbing the ladder. Access to the roof should be limited to cleaning and sealing purposes only. Remove the bottom step section to open rear engine access door.

**NOTE: Maximum weight is 300 lbs.**

## FANS - Attic Exhaust Fan

The exhaust fan is a three-speed fan with a “0” or **OFF** position on the fan. The exhaust fan requires the presence of 12 Volt DC to operate. The fan will either pull in air or extract air from the motorhome depending on how the **IN/OUT** switch was set. The **IN/OUT** switch controls the direction of the fan rotation. There are three basic controls located on the ceiling vent fan. The knurled knob manually opens and closes the dome cover. The rotary knob selects the operating speed of the fan. When the dome cover opens about two inches, the fan motor begins to operate. During normal operations the knurled knob offers manual control of the dome cover for opening and closing.

### To Operate the Fan:

- The Battery cut-off switch needs to be set **ON**.
- The dome manually opens and closes using the knurled knob.
- Set wall thermostat at desired setting.
- Select the desired fan direction to **IN/OUT**.
- Select the desired fan speed on the Speed

Control dial:

**Zero = OFF.**

**One = LOW.**

**Two = MEDIUM.**

**Three = HIGH.**

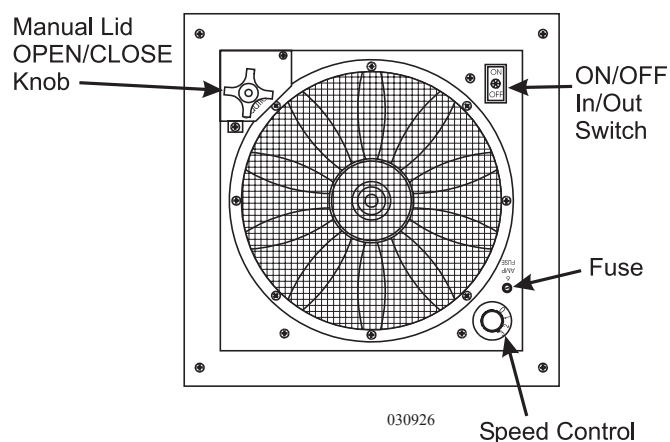

**NOTE: Let fan come to a complete stop before changing fan direction.**

**NOTE: If the speed switch is in the "0" position the fan operates only as a vent.**

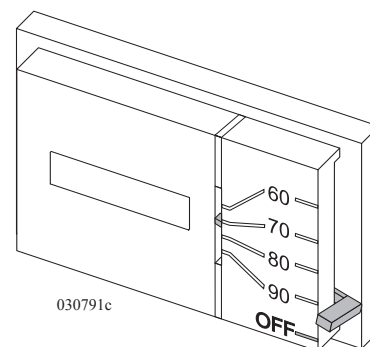

### Tips:

- To keep condensation from accumulating open the vent fan lids slightly to help the air circulate. Condensation occurs naturally from fluctuations in interior and exterior temperatures, humidity and dew point changes, steam from cooking, or boiling large amounts of water on the cooktop. Shower usage also produces condensation.
- If the fan fails to operate, check for either a blown fuse in the domestic fuse panel or the 6-amp fuse on the fan.
- To clean the screen, remove the eight screws holding it in place. Wash the screen using a non-abrasive soap and water. Re-install the screen and tighten the screws.

- Keep all the vents closed when using the Fantastic Fan Vent. Direct the airflow by slightly opening the window(s) on the shaded side of the motorhome to obtain the maximum airflow, especially on hot, sunny days. Close all the roof vents. The area between the open window(s) and the Fantastic Vent supplies the maximum airflow and providing the most comfort.

**NOTE: Do not leave the vent cover open while the motorhome is in motion, stored or unattended for extended periods. High winds, other unusual conditions or obstructions may prevent closing. The resulting leakage could cause serious damage.**

---

### ***Bathroom Fan***

The motorhome is equipped with roof air vents which are manually operated. The vent is opened or closed by simply turning the crank handle in the desired direction. The fan, which is for ventilation only as it will not help cool the motorhome, can be operated by pushing the small power button. The vent must be opened before using the power fan. To close the power air vent, push in the power button to stop the fan and close the vent.

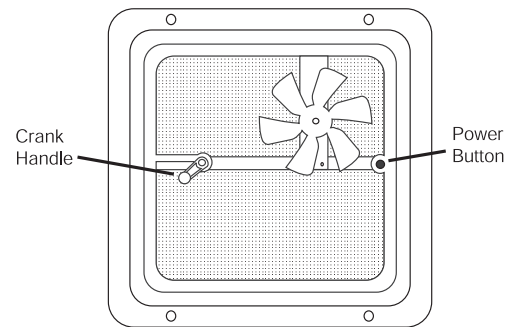

030842

---

### ***Rain Sensor Exhaust Fan (Optional)***

The three-speed rain sensor exhaust fan operates from 12 Volt DC power. Three basic controls, located on the fan, are Adjustment, Fan Speed and Fan Blade IN/OFF/OUT.

During normal operations, the Adjustment knob offers manual control of the dome cover for opening and closing. After the dome opens, pull adjustment knob down to Manual, then adjust the dome height and immediately push up and back to Auto. After adjusting the dome, check knob to insure it is locked into the gearbox. When the rain sensor is wet, using the Adjustment knob can manually open the dome to override the rain sensor.

**WARNING: Keep fingers away from Adjustment Knob while dome is automatically opening or closing, unless deliberately intending to apply opposite force to stop the dome partially open.**

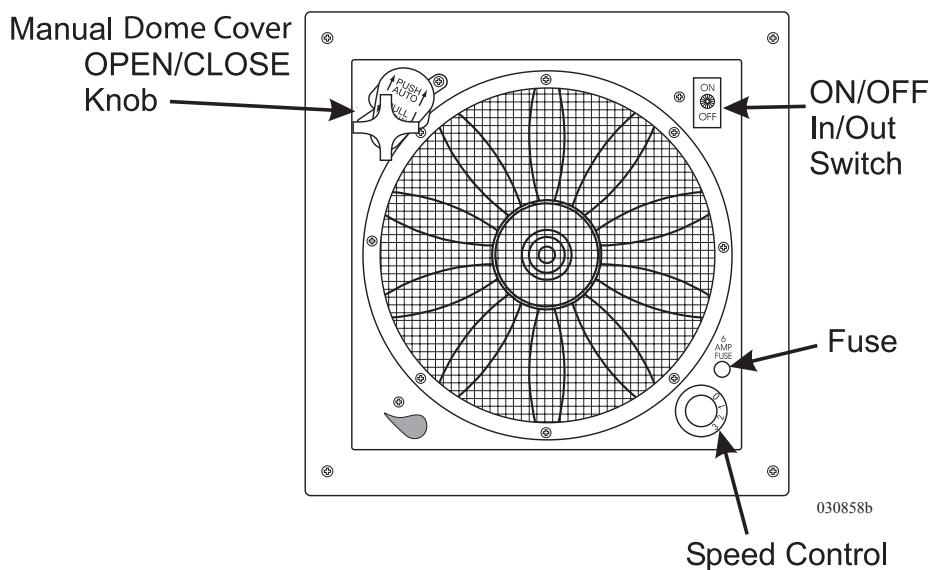

Fan Speed controls the operation speed of the fan blade. The blade can be set between the "0" which represents OFF, to "3" which represents the fast blade setting.

IN/OFF/OUT controls fan direction, which determines airflow direction through the exhaust fan. When the dome cover opens about two inches, the fan motor begins to operate. By pressing the IN/OFF/OUT switch to the IN position, exterior air passes through the exhaust fan into the motorhome. By pressing the IN/OFF/OUT switch to the OUT position, interior air passes through the exhaust fan to the exterior of the motorhome. By pressing the IN/OFF/OUT switch to the center, OFF position, the fan blade operation will cease. The rain sensor is always active in any mode. If the fan blade is in the OFF or IN mode, rain can infiltrate the motorhome until the dome is closed via the rain sensor.

The wall thermostat is for automatic control of the exhaust fan. Select a maximum ambient temperature between 60°F to 90°F. When the interior ambient temperature is warmer than the thermostat setting, the dome opens automatically and the fan blade turns on to the pre-selected speed and direction. When the motorhome cools below the thermostat setting, the dome closes and turns the fan blades off.

#### **To Operate the Fan:**

- The Battery cut-off switch needs to be ON.
- Select the desired fan direction to IN/OUT.
- Select the desired fan speed.
- Select the maximum ambient temperature on the wall thermostat.

**NOTE: Let fan come to a complete stop before changing fan direction.**

**NOTE: If the speed switch is in the "0" position the fan operates only as a vent.**

## Tips

- To keep condensation from accumulating open the vent fan lids slightly to help the air circulate. Condensation occurs naturally from fluctuations in interior and exterior temperatures, humidity and dew point changes, steam from cooking, or boiling large amounts of water on the cooktop. Shower usage also produces condensation.
- If the fan fails to operate, check for either a blown fuse in the domestic fuse panel or the 6-amp fuse on the fan.
- To clean the screen, remove the eight screws holding it in place. Wash the screen using a non-abrasive soap and water. Re-install the screen and tighten the screws.
- Keep all the vents closed when using the Fantastic Fan Vent. Direct the airflow by slightly opening the window(s) on the shaded side of the motorhome to obtain the maximum airflow, especially on hot, sunny days. Close all the roof vents. The area between the open window(s) and the Fantastic Vent supplies the maximum airflow and provides the most comfort.

**NOTE: Do not leave the vent cover open while the motorhome is in motion, stored or unattended for extended periods. High winds, other unusual conditions or obstructions may prevent closing. The resulting leakage could cause serious damage.**

---

## POWER SUNVISOR

The cockpit blinds are 12 Volt DC operating from the house batteries. One blind assembly is used for each window located in the cockpit area.

### To Operate the Blind:

- The house battery cut-off switch must be on.
- Push the switch down to lower the desired blind.
- Push the switch up to raise the blind.

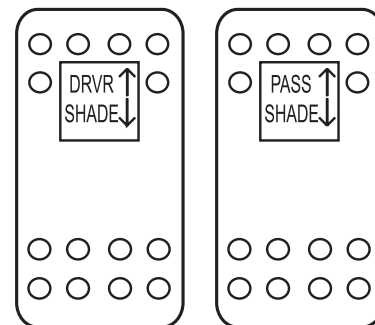

080494

**NOTE: Do not attempt to move or drive the motorhome with any blind in the lowered position.**



**SEAT CONTROLS**

The pilot and co-pilot seats are adjustable to provide maximum comfort. The seats must be locked in the forward facing direction while in transit.

**NOTE:** The seats operate from 12 Volt DC house power.

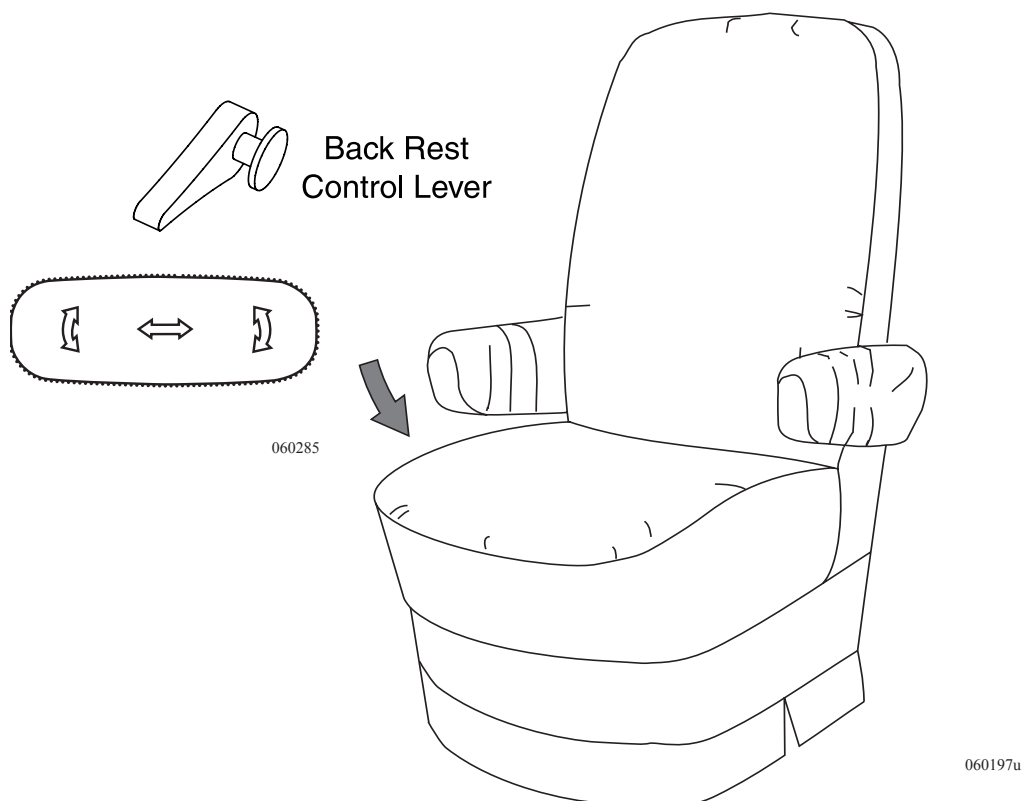
**Swivel Seats****Swivel Seat Operation:**

- When swiveling a seat, lift up the swivel lever and rotate to the desired position.
- The passenger seat swivels all the way around, when the slide-out is extended.
- When rotating the driver seat, put the steering wheel in the upright position.
- Move the seat forward, then pull the swivel lever up and rotate around to the desired position.

**WARNING:** Seats must be locked in the forward facing position while the motorhome is in transit.

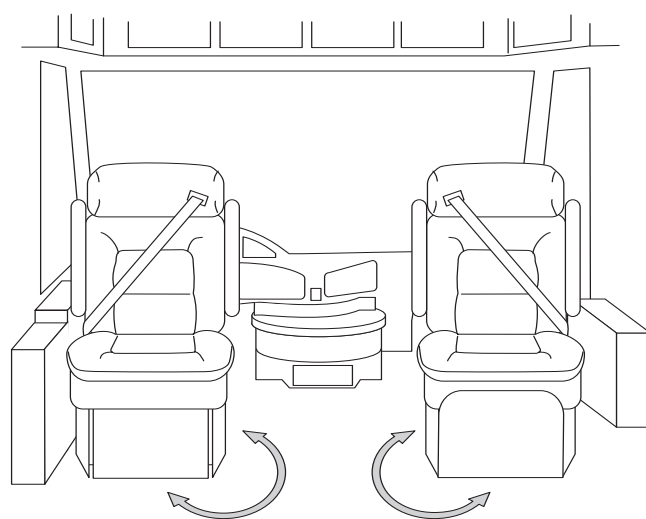

## SOFA - Easy Bed Sofa

The sofa will convert easily into a bed. Clear the area of obstruction. The sofa comes equipped with safety belts and these should be used if occupied during travel.

### Sofa to Sleeper:

- If applicable, slide the lever forward to release the locking mechanism.
- Raise the sofa seat base until seat base and backrest form a “V” shape by lifting up from the center of sofa just below the seat cushions.
- Push down on seat base until the seat base and backrest are flat.
- Fold seat belts out of the way.

### Sleeper to Sofa:

- Lift the seat base up until seat and back rest are in a “V” shape.
- Push down on seat base.

**WARNING: Do Not use the sofa for transporting infants or children that require safety seats or booster seats.**

## Hide-A-Bed Conversion (Optional)

The sofa hide-a-bed will convert easily into a bed. Clear the area of obstruction and debris. The sofa comes equipped with safety belts to be worn if occupied during travel.

### Sofa to Sleeper:

- Remove the three seat cushions to access the hide-a-bed. The seat cushions should be stored safely until the bed is converted back to a sofa.
- If applicable, release the lock on the right side of metal bar, grasp the front metal bar and lift up pulling out on the bar slightly until the leg of the bed is firmly resting on the floor.
- Fold seat belts out of the way.
- When the legs of the bed are firmly on the floor there will be another lifting bar exposed to complete the conversion process.
- Grasping and opening the lifting bar will open the bed fully. The bed is now ready for linen.

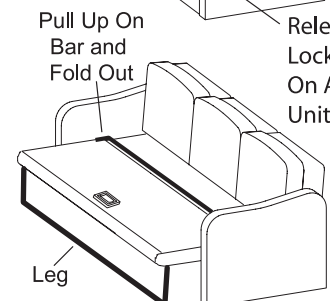
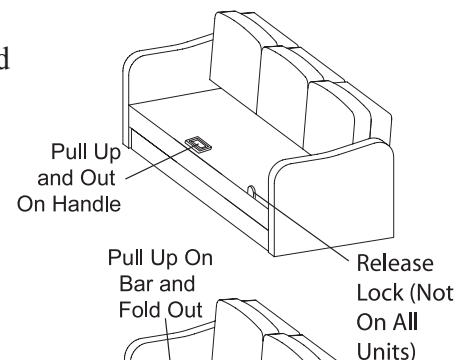
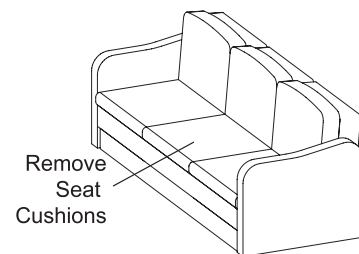
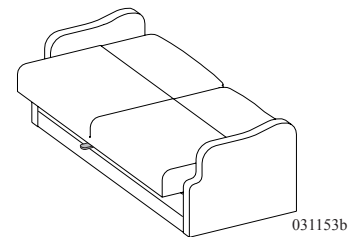
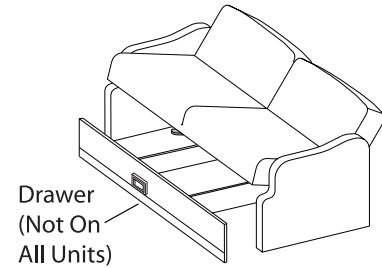
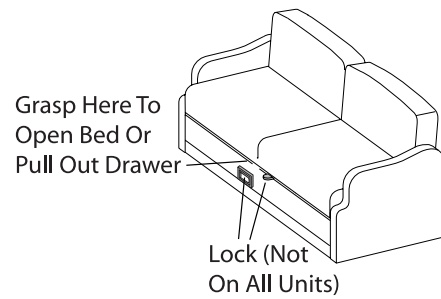

**Sleeper to Sofa:**

- Remove all bedding from the hide-a-bed.
- Grasp the foot of the hide-a-bed in the center using the metal lifting bar.
- Fold over the bottom portion of the bed that will form the seat.
- Lift the front portion of the lifting bar to raise and lower the hide-a-bed back into the sofa base.
- Position the seat belts for use.
- Replace the seat cushions.

**Air Mattress (Optional)**

The Air Mattress inflates and deflates in a matter of a few seconds. Inflating the mattress is accomplished by using an electric pump. The pump operates from any 120 Volt AC outlet.

**To Inflate the Mattress:**

- Open sofa and allow the mattress to lie flat.
- Unzip the corner of the mattress labeled “Air Pump Access.”
- Ensure the valve is locked securely in place.
- Remove the cap from the valve by squeezing the tabs on each side of cap.
- Place the pump into the valve and turn pump ¼ turn clockwise to lock pump into valve.
- Plug in the pump motor to inflate to a desired firmness.
- Remove the pump, reinstall the cap on the valve and zip the “Air Pump Access” cover closed. The bed is now ready for linen.

**To Deflate the Mattress:**

- Remove bedding items.
- Unzip the corner cover of the mattress labeled “Air Pump Access.”
- Press tab on the side of valve and pivot valve up to release the air in mattress.
- Once mattress is deflated allow valve to rest loosely on valve seat, DO NOT LOCK VALVE CLOSED.
- Zip the “Air Pump Access” cover closed and close the sofa.

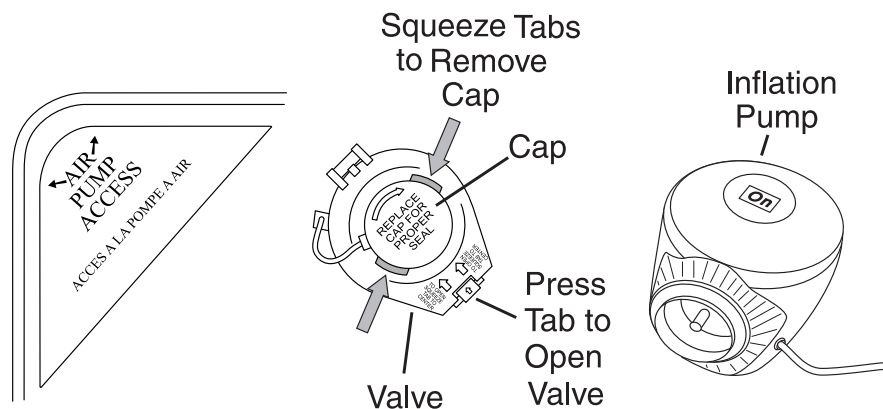

020260b

## Wonder Bed Conversion (Opt)

The sofa Wonder Bed will convert easily into a bed. Clear the area of obstruction and debris. The sofa also features a slide-out storage drawer. The sofa comes equipped with safety belts to be worn if occupied during travel.

### Sofa to Sleeper:

- Remove the three back cushions to access the Wonder Bed. The back cushions should be stored safely until the bed is converted back to a sofa.
- Raise the sofa seat base until seat base and backrest form a “V” shape by lifting up from the center of sofa just below the seat cushions.
- Push down on seat base until the seat base and backrest are flat.
- Fold seat belts out of the way.
- Fold the seat cushion out to form the bed.

### Sleeper to Sofa:

- Remove all bedding from the Wonder Bed.
- Fold the bottom cushion to form the sofa seat cushion.
- Lift the seat base up until seat and back rest are in a “V” shape.
- Push down on seat base to form the sofa.
- Install the three back cushions.

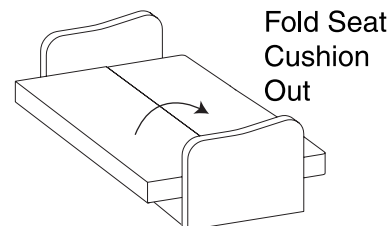
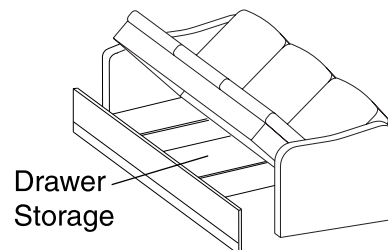
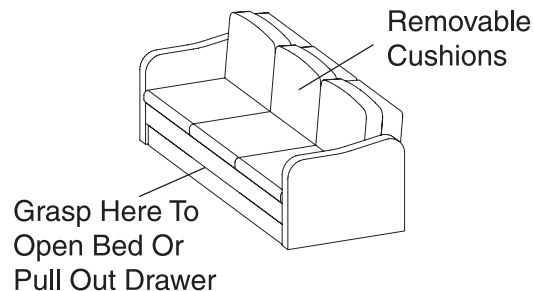

020222F

## Electric Sofa Bed Conversion (Optional)

The sofa will convert easily into a bed. Clear the area of obstruction. The sofa comes equipped with safety belts and these should be used if occupied during travel.

### Sofa to Sleeper:

- Unlock latch at bottom center of sofa and pull bed extension frame out all the way.
- Lift bed extension cushion up and pull out all the way to lock into extension frame.
- Push switch on sofa arm to position back and bottom cushions flat against the bed extension cushion.

### Sleeper to Sofa:

- Push switch on sofa arm so that back and bottom cushions are in the sofa position.
- Push in and down on the bed extension cushion to place cushion in stored position on frame.
- Push bed extension frame under sofa into locked position.
- Position seat belts for use.

## STORAGE - UNDER BED

To use the storage compartment located under the bed, locate and unlock the bed deck latches. Lift up the bed by the front edge of the mattress platform. Gas struts hold the mattress and platform open.

**NOTE: Do not over stress gas struts by rapidly opening or closing the bed access cover, as this action can damage the struts or mounts. In extreme cold gas struts may not hold the mattress platform in the open position.**

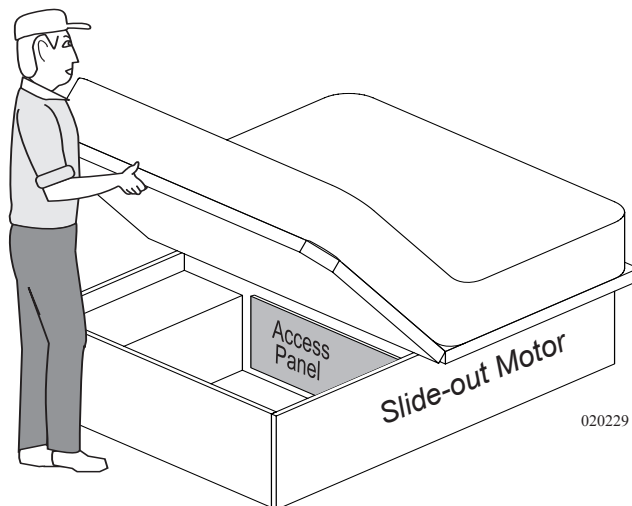

020229

### DINETTE - Bed Conversion - Rotocast

The booth dinette converts quickly and easily into a bed.

#### Use the Following Procedure:

1. Remove the table top from the leg supports and set aside.
2. Remove the leg supports from the base and store.
3. Slide the table top between the booth benches allowing it to rest on the guide rails.
4. Lay both seat cushions and back cushions together to form a mattress.

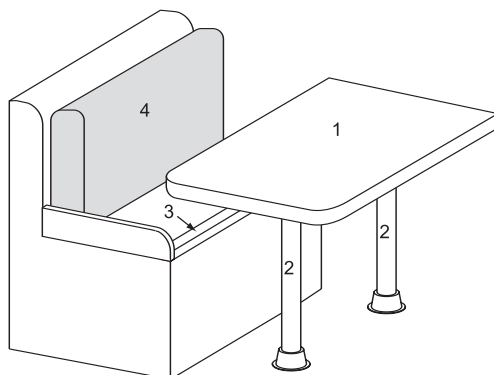

020184b

- To extend table top, unlock and slide table top all the way against stop.
- Reverse procedure to store table top leaf.

## Dinette Bed Conversion (Optional)

The booth dinette easily converts into a bed.

- Lift or remove the seat cushions to permit the table to swing down into position.
- With a firm grip, lift front edge of the table about six inches and push table leg lock to release support leg.
- Swing the table leg up locking the leg into the horizontal position.
- Continue lifting table until table stays are clear of retainers. Pull outward and lower table down.
- Use both seat cushions and one back cushion for a mattress. Leave one back cushion in a vertical position.

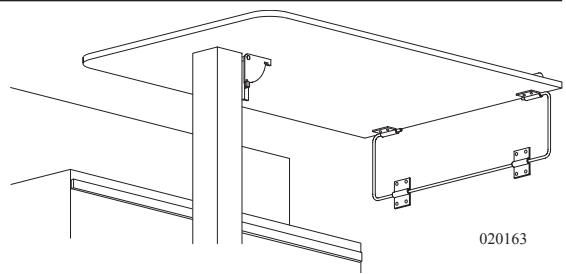

**WARNING:** When the motorhome is in motion, do not occupy the dining chairs or the booth dinette, if it is not equipped with safety belts. Chairs must be stored in an enclosed area or secured with straps while the motorhome is in motion to avoid personal injury.

## FLIP UP TABLE (OPTIONAL)

### To Extend Table:

- Lift bottom of table and push table leg lock to release the support leg.
- Raise the table top and lower support leg so that it locks in a vertical position.
- Lower table.

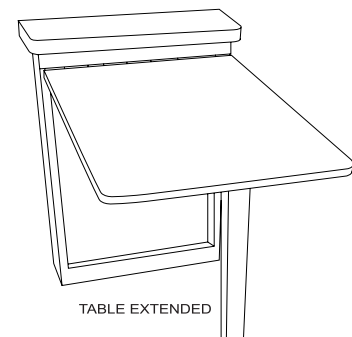

### To Store Table:

- Lift table up and push table leg lock to release support leg.
- Fold support leg against bottom of table top so that it locks in stored position.
- Lower table top into stored position.

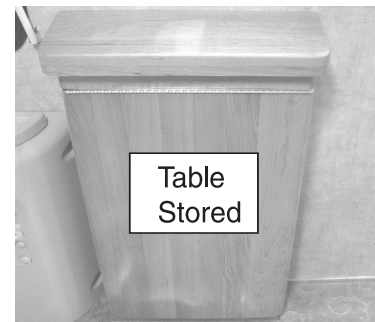

## STORAGE BAY SLIDE-OUT TRAY (OPTIONAL)

The super slide is an option that is available for use in the storage compartment bays of the motorhome. This allows for the pay-load to slide outward for easier access.

- The motorhome must be level before opening.
- There are two latch releases: lift and hold up to release one, pull outward while pulling on the slide to release the other.
- Maximum weight capacity is 1,000 lbs. Never exceed this amount.

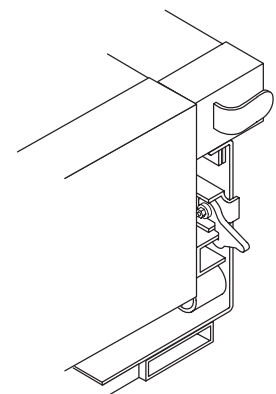

**WARNING:** The motorhome must be level when sliding the drawer out of the bay compartment. The drawer can slide out abruptly, if the motorhome is not level, and cause bodily harm.

## ENTERTAINMENT SYSTEMS

The components used to make up the entertainment center are carefully selected to provide the highest quality in audio and visual enjoyment. There are several pieces of equipment, which encompass the entertainment center. The following paragraphs will discuss the operations and various components. Use the instructions given in the Video Selector Box section to use these components.

### Hook-ups - TV Cable, Computer & Telephone

The motorhome is equipped with cable TV, satellite TV, 120 Volt AC electric outlet and telephone hook-ups, located in the various outside bays. For convenience, there are auxiliary outlets located at the co-pilot seat and on the optional computer desk. This connection is set up for a telephone or laptop computer.

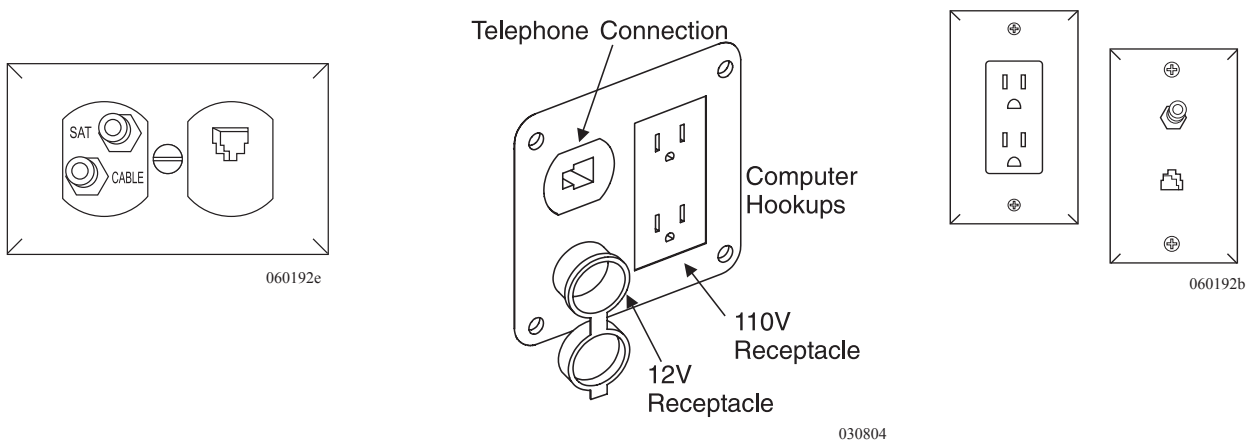

### Television (Front) w/Lock-out Feature

The Main TV has lockout circuitry. Simply stated, the ignition switch controls the front TV power outlet. Only with the ignition OFF will the front TV operate. No other television set is affected by the lockout circuitry. The TV operates on 120 Volt AC power only. This power can be provided by shore power, the generator or the inverter. Viewing time of the front TV from the inverter depends on the state of charge of the house batteries and any additional 12 Volt DC circuitry which is being operated.

## Television Antenna

The television antenna is a manual crank up style antenna with built in electronics that use 12 Volts DC to "boost" signal strength. Signals that are weak or fuzzy can be amplified by turning on the TV Ant Power switch on the Video Selector Box. The antenna and booster work together to provide the best possible picture for most situations. Certain conditions occur when no amplification is needed, and in fact may make the picture worse. The television station will send a signal that resembles the waves or rings of water from a rock thrown into a still pond. The radiating television signal can hit an object such as a mountain and come back. The result one sees in the television picture is a double image. The antenna will receive a signal from the initial pass, and then receive an additional signal from the rebound resulting in a split or double image. In this case, the picture may be improved by no amplification or even lowering the antenna.

**NOTE:** Do not move the motorhome with antenna in the raised position, it can be damaged by tree limbs or wires.

**WARNING:** Before raising antenna make an outside, visual inspection for any obstructions or overhead electrical wires. Damage to the antenna, severe shock, personal injury or death can occur from inadequate clearance.

### To Raise the Antenna:

- Rotate the crank handle clockwise to raise the antenna (about 14 ½ turns).
- Pull down on the outside directional wheel and rotate the antenna until the best picture is obtained. The directional wheel is spring loaded.

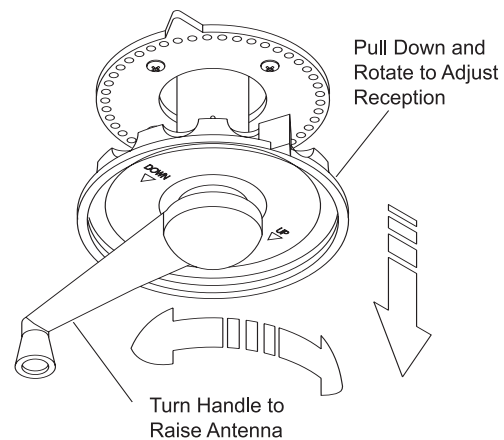

**WARNING:** Do not raise a TV antenna near overhead electrical wires as contact may cause serious injury or death. The motorhome must not be driven with the antenna in a raised or partially raised position. Worm gear or worm breakage may result.

130024

### To Lower the Antenna:

- Pull down on the directional wheel and align arrows together.
- Rotate the crank handle counterclockwise to lower the antenna fully into the cradle. Make an outside visual inspection to ensure the antenna is properly stowed.

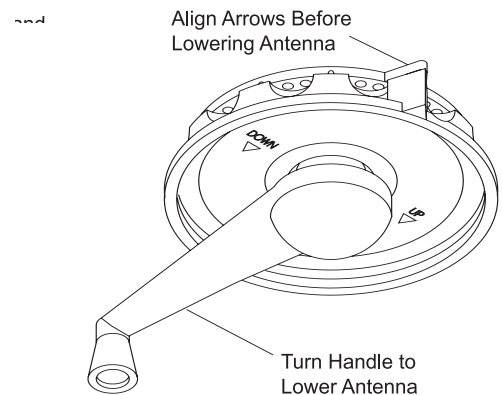

130024



**Troubleshooting the Coax Wire:** Weak or no picture can indicate a possible shorted or open coax. The coax cable is made of two conductors: A center conductor usually of copper and a ground that is woven of braided aluminum. The "die-electric" insulating material separates the two conductors. The ground and center conductors are to remain electrically separate from one another. When installing a F-connector onto a coax cable, use care so none of the woven ground strands makes contact with the center conductor. A continuity tester is required to test a suspected fault in a coax wire. Unscrew both ends of the suspected bad coax run, with the continuity tester check between the center conductor and the outside threaded ring. If continuity is present, the coax is shorted. To test for an open connection of a particular coax run, use one test lead and touch the threaded end of the coax. With the other test lead, touch the threaded ring at the opposite end. Continuity should be present. Perform the same test procedure on the center conductor. Proper electrical coax operation should indicate continuity from the center conductor at one end to center conductor at other end. Continuity should be present between each coax terminal end. There should be no continuity between the terminal end and center conductor. Though damage does not usually occur from a shorted or open coax cable, picture quality is compromised.

**Television Set:** Ensure the television set will select channel 3. The TV menu may need programmed. ie: Input Video Signal Type, Channel Programming or Signal Output Levels.

**NOTE:** TV channels and the alternate input FRNT may need to be programmed. To program press Menu on the TV remote. Select 4 Channel from the main menu. Select 3 List and Labels. Use cursor to select channel. FRNT is located below channel 2.

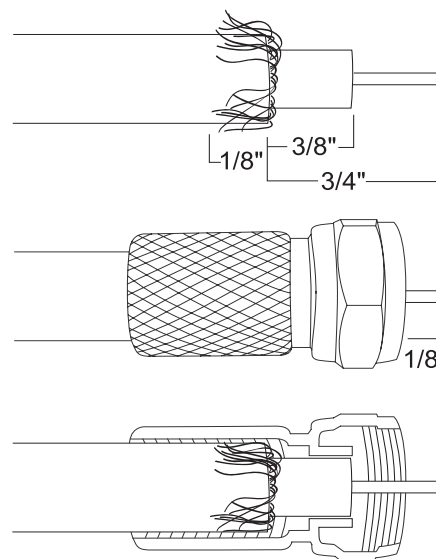

### Video Cassette Recorder (VCR) (Optional)

The videocassette recorder is the same one found in most homes. The VHS compatibility allows recording and playing back programs on standard VHS tapes. The Audio/Video Input Jacks in the front allows for quick, easy connections of additional video equipment.

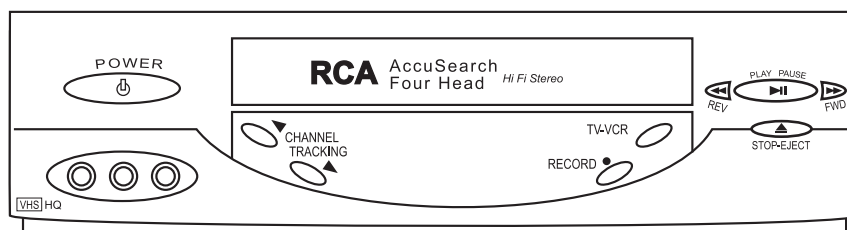

## DVD Player (Optional)

The DVD Player is a multi-functional component that features a 5-Disc DVD/CD Changer, MP3 and JPEG Playback as well as a built in Tuner with 40 FM station presets.

**INFORMATION:** For detailed information and operating instructions on the DVD Player, refer to the manufacturer’s manual located in the Owner’s Information File.

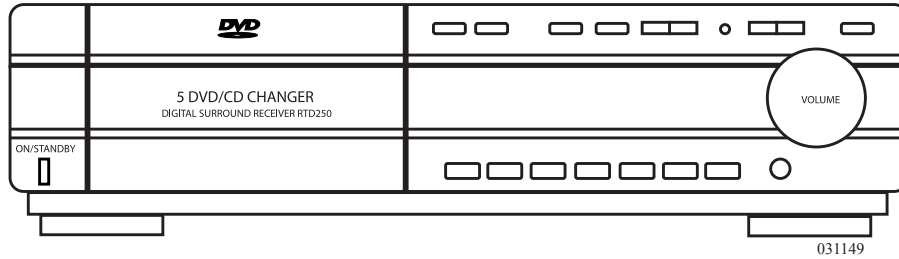

## Video Selector Box

The motorhome is equipped with a video selector box which has six inputs and four outputs.

### Features Include:

- Push button controls allow you to send signals from any one of six different inputs to three TVs and VCR.
- Six inputs are Satellite Receiver, TV Antenna, VCR, DVD, Cable TV & Auxiliary.
- 4 Outputs: Main TV, TV2, Exterior TV and VCR.
- Built-in +12 VDC TV antenna power supply eliminates need for separate wall mounted TV antenna power supply.
- Self-resetting fuses used in antenna power supply prevent failure caused by shorted connections.
- Video switch allows for independent viewing of signals at different TVs, with a record option from VCR.

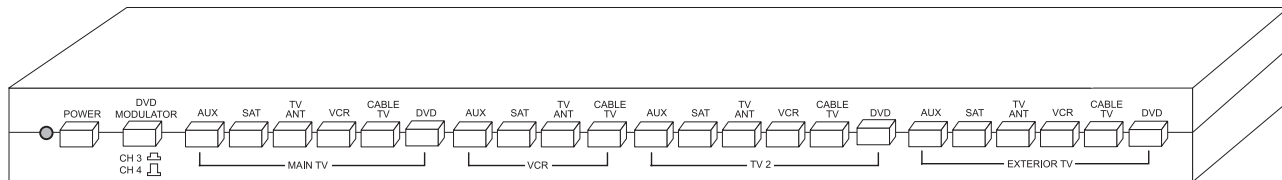

030861c

**To Watch TV Using Antenna:** To view signals from an amplified TV Antenna, first press the TV antenna POWER button to the ON position. This provides +12 Volt power to the TV antenna amplifier located inside the antenna housing. To view the TV antenna signal on the main TV, simply press the TV ANT button located above the area marked “MAIN TV.” Follow the same procedure for TV 2 or exterior TV. Turn TV ON and select channel.

---

**NOTE:** The picture quality from the outdoor TV antenna varies depending on the location of the TV station in relationship to the location of the TV antenna. If picture quality is degraded and you are not using an external power supply, try turning the TV Antenna Power button located on the control box OFF and ON.

**To Watch TV Using Cable Signal:** To view Cable TV signals on the main TV, press the CABLE TV button above the area marked “Main TV.” Follow the same procedure for TV 2 or exterior TV. Turn TV ON and select channel.

**NOTE:** To view Cable TV signals, you must be connected to a Cable TV input on the outside of the motorhome. Cable TV inputs are available at many of today’s campgrounds.

**To Watch TV using Satellite Signal :** To view Satellite signals on the main TV, press the SAT button above the area marked “Main TV.” Follow the same procedure for TV 2 or exterior TV. Turn TV ON and select channel 3. Use Satellite receiver to select channels.

**To Watch TV using VCR Signal:** To view VCR signals on the main TV, press the VCR button above the area marked “Main TV.” Follow the same procedure for TV2 or exterior TV. Turn TV ON and select channel 3. Turn VCR ON and insert video tape to view.

**To Watch TV using DVD Signal:** To view DVD signals on the main TV, press the DVD button above the area marked “Main TV”. Follow the same procedure for TV2 or EXTERIOR TV. Press DVD MODULATOR button to choose CH3 or CH4. Turn TV ON and select channel to match DVD MODULATOR channel chosen. Turn DVD ON and insert DVD disc to view.

**To View Auxiliary Components using TV:** To view Auxiliary signals, such as game consoles, camcorder, etc., on the main TV, press the AUX button above the area marked “Main TV.” Follow the same procedure for TV 2 or exterior TV.

**Recording Using VCR:** To record programming from the Antenna, Satellite Receiver, Cable TV or Auxiliary, simply press the appropriate button above the section marked VCR.

- To record programming from the TV Antenna to the VCR, press the TV ANT button above the VCR section on the switch box.
- To record programming from the Satellite Receiver to the VCR, press the SAT button above the VCR section on the switch box.
- To record programming from an Auxiliary device to the VCR, press the AUX button above the VCR section on the switch box.
- To record programming from Cable TV to the VCR, press the CABLE TV button above the VCR section on the switch box.

## Satellite System - Prewire

The motorhome is prewired for a roof mount Satellite System. The prewire will consist of a 3/4" flexible conduit, which will run from the front overhead connection panel to a spot marked on the roof. A telephone hook-up will also be provided for Pay Per View accessibility.

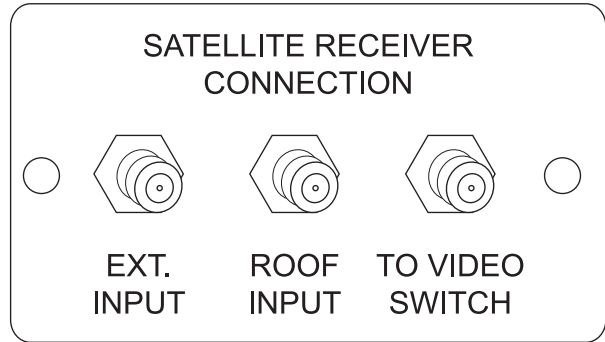

031070

## SATELLITE SYSTEM (OPTIONAL)

The TracVision SF is a self-contained stationary, automatic satellite TV system. The TracVision SF automatically acquires and tracks DirecTV®, DISH Network™ and Bell ExpressVu satellite signals throughout the continental United States when the motorhome is in a stationary position.

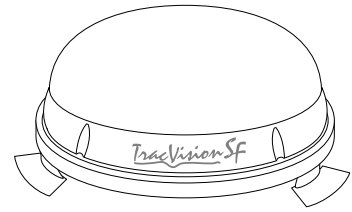

030125

**WARNING:** TracVision SF is a self-acquiring satellite TV antenna for use when the motorhome is stationary. The system is not designed to track the TV satellite when the motorhome is in motion.

**NOTE:** For specific satellite coverage areas and providers visit KVH online at [www.kvh.com](http://www.kvh.com).

## Integrated Receiver Decoder

The IRD receives satellite signals from the antenna unit for signal decoding, processing, and channel selection, and sends the signals to the TV for viewing. The IRD also provides the interface for the user to activate authorization for reception.

**NOTE:** Refer to the Satellite Receiver User's Manual for complete operating instructions.

## Operation

The TracVision SF satellite system requires a clear view of the southern sky to receive satellite signals, the ideal antenna site has an unobstructed view of 15° - 75° in the Southern horizon.

If the satellite antenna receives intermittent signals or cannot locate the satellite, check around the motorhome for any objects that could be blocking the signal, such as trees, building, etc. The satellite antenna must be located in the selected satellite's coverage area in order to receive a signal.

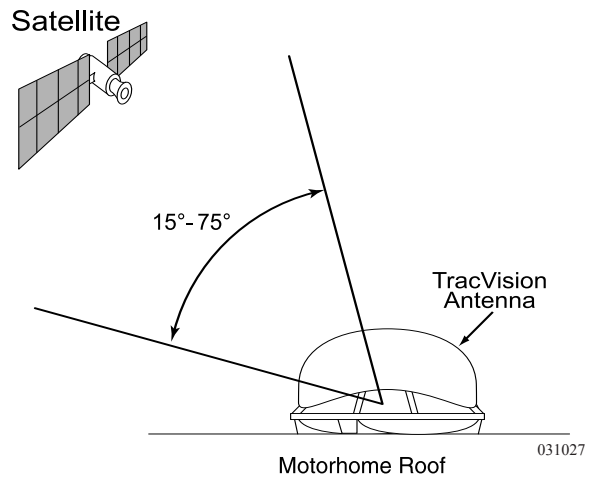

031027

**To Turn the TracVision SF Satellite System ON:**

1. Park the motorhome.
2. Turn **ON** the Interior House power using the Battery Cut-off Switch.
3. Turn **ON** the IRD.
4. Press the Switch Plate's **POWER** button.
5. Using the Video Selector Box, press the SAT button above the area marked "Main TV." Follow the same procedure for TV2. Turn the TV ON and select channel 3. Use the IRD to select channels.

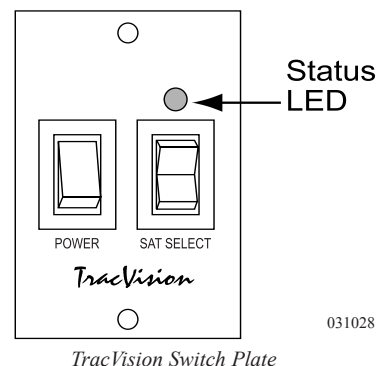

TracVision Switch Plate

**NOTE:** As part of the startup process, the TracVision SF System will default to channel 200, a program directory. This is the system's means of verifying that it has identified and is tracking the correct satellite. Once channel 200 appears, wait at least another 30 seconds before changing the channel to ensure that the system has completed the startup routine.

**System Start-up:**

- Upon power-up, the system performs a set of start-up routines.
- Antenna then searches for a TV satellite.
- After locating a satellite, it uses the IRD data connection to determine if the satellite signal can be decoded. If the signal can be decoded by the IRD, the antenna locks onto and tracks the satellite.

**NOTE:** Once the startup procedure is complete and the antenna is locked onto the correct satellite, the TracVision SF does not need to remain on. The TracVision SF unit may be turned off to avoid unnecessary usage of battery power. Because the antenna LNB receives its power from the IRD, the antenna will continue to receive the satellite TV signals and relay them to the IRD.

**NOTE:** If the antenna is unable to locate the desired satellite, refer to Section 4 "Troubleshooting" of the TracVision SF User's Manual for possible causes and their corrective actions.

**"Instant On" Operation:** As part of its operation, the TracVision SF routinely saves the satellite position to memory and retains it when the system is turned off. When TracVision SF is powered up, the system looks at the satellite's last saved position. If the vehicle has not changed its location, the antenna will immediately acquire the satellite and receive the signal without initializing the antenna.

If the motorhome moves after the TracVision SF is turned off, the antenna unit will quickly carry out its normal initialization routine to reacquire the satellite.

To turn off the TracVision SF system, simply press the switch plate's **POWER** button.

**WARNING:** It is highly recommended that the TracVision SF be turned OFF prior to moving the motorhome. TracVision SF will not track a satellite while the vehicle is in motion.

## **Maintenance**

TracVision SF requires minimal preventive maintenance. The following tasks are sufficient to maintain peak performance.

### **Monthly:**

- Wash the exterior of the radome and baseplate assembly with fresh water; a mild detergent may be added to remove grime. DO NOT spray the radome directly with high-pressure water.
- DO NOT apply abrasive cleaners or volatile solvents such as acetone to the ABS dome.

### **Annually:**

- Have the TracVision SF satellite system inspected by a professional RV Technician or TracVision satellite installer.
- Apply liquid dish detergent to the dome surface. Wipe the full-strength detergent on the dome and allow to dry. This treatment will provide a film that will help moisture bead up and roll off the dome.

**NOTE: If a need arises to paint the radome, ONLY use non-metallic automotive paint to avoid degrading the RF signal strength and the reception quality.**

**INFORMATION: For information on KVH warranty, repair, and liability policies, please refer to the complete warranty statement provided with the KVH User's Manual.**

---

## **RADIO - DASH**

The dash radio is a tuner and a compact disc player. Holding up to fifteen preset FM stations and ten AM stations. Other features are clock display, auto seek and scan tuning and weather band operation. The compact disc player features are fast forward and reverse, random track play, repeat and pause.

### **Operation:**

- Turn ON the house battery disconnect switch.
- Turn ON the house battery cut-off switch, located at the entry door.
- Turn ON the radio power switch at the dash panel.
- To turn the radio ON, push the ON button.
- To turn the radio OFF, push the ON button for about two seconds.

**INFORMATION: Additional and detailed information for the dash radio functions and operations can be found in the Owner's Information File Box.**

---

## **Citizens Band Radio - Prewire**

A two pin connector labeled Citizens Band Radio is located behind the dash panel. It is taped along with the CB Antenna coax, which is routed to the roof mounted base. The red wire is at 12 Volt DC and is fused at two amps through the front distribution panel. The white wire is connected to the frame.

## EXTERIOR ENTERTAINMENT CENTER (OPTIONAL)

The entertainment center has a AM/FM marine stereo radio with two speakers. The stereo has conformal coated circuit board to withstand salt air and humidity along with UV stable detachable control panel and electronic tuner.

Included are 12V DC, 120V AC antenna receptacles. The locking cover should be closed and locked when the entertainment center is not in use.

### Function of Features:

**ON/OFF POWER BUTTON (PWR)** - Press this button to turn the unit on or off.

**VOLUME/LEVEL CONTROL (VOL)** - To increase the volume level, press the up arrow button. To decrease the volume level, press the down arrow button.

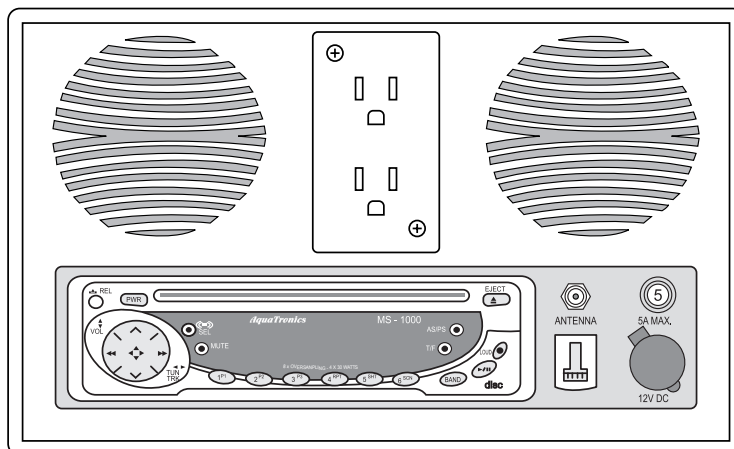

020154

**SELECT BUTTON (SEL)** - This button is used to select the audio function (volume, treble, bass, balance, or fade) to be adjusted using the Level Control. Pressing the Select button once will set the unit for volume adjustment (“VOL” will appear on the display panel). Pressing the button additional times will select treble (“TRE” on the display), bass (“BAS”), balance (“BAL”), fader (“FAD”) or volume (“VOL”).

**AUDIO SETTING MEMORIES (P1/P2/P3)** - Three pre-set buttons are provided on this unit to store desired audio level positions into memories which can be easily recalled. To set any of the 3 audio memories, use the following procedure:

1. Use the Select button and Level control to adjust the setting of the volume, treble, bass, balance and fader to the desired positions.
2. Press the Select button to call any of the audio functions on the display. Within 2 seconds of pressing the Select button, and while the audio function is still on the display panel, press the pre-set button (1 through 3) to be set and continue to hold it in. After about 2 seconds, the pre-set number (“P-1”, “P-2”, or “P-3”) will appear on the display panel indicating that the audio levels are now set into that memory position. The settings can be recalled at any time by pressing the Select button and then that pre-set button within 2 seconds.

**AUDIO MUTE (MUTE)** - This button is used to mute the volume from the system. By pressing the button, the indication “MUTE” will appear on the display panel and the volume will be muted. Pressing the Mute button again will return the volume level to the setting in use before the Mute function was activated.



**AM/FM BAND SELECTOR (BAND)** - During radio operation, each momentary press of this button will change the radio band. The indication “AM1”, “AM2”, “FM2”, or “FM3” will appear on the display panel according to your selection.

**MANUAL UP/DOWN TUNING & AUTOMATIC SEEK TUNING (TUN)** - Each time the right arrow button is tapped, the radio will tune one frequency step higher. Similarly, each tap of the left arrow button will tune one frequency step lower. To manually tune in a station, tap the button of the appropriate direction until the desired frequency is reached. Pressing either button for longer than 0.5 seconds and then releasing will activate the Automatic Seek Tuning function. The radio will seek the next available station and stop at the frequency. The Seek function can be stopped by pressing the button again or activating any other tuning function.

**AUTO-STORE TUNING (AS) & PRE-SET SCAN TUNING (PS)** - During radio operation, press this button momentarily to scan the 6 stations pre-set into the memories of that band. The unit will stop at each pre-set station for 5 seconds before continuing to the next pre-set station. Press the button again momentarily to stop Pre-Set Scan operation and remain on the selected frequency. Pressing the button for longer than 2 seconds will activate the Auto-Store Tuning feature which will automatically scan the band and enter up to 6 strong stations into the 6 pre-set memories.

**STATION PRE-SET MEMORIES** - To set any of the 6 pre-set memories in each band, use the following procedure:

1. Turn the radio on and select the desired band.
2. Select the first station to be pre-set using the Manual Up/Down or Automatic Seek Tuning controls.
3. Press the pre-set button to be set and continue to hold it in. After about 2 seconds, the pre-set number will appear on the display panel, indicating that the station is now set into that pre-set memory position. The station can now be recalled at any time by pressing that button.
4. Repeat the above procedure for the remaining 5 pre-sets on that band and for the other 4 bands on the unit.

**DISC SLOT** - With the label surface facing up, gently insert the disc into the slot until the soft-loading mechanism engages and disc play begins.

**TRACK SELECT (TRK)** - These buttons are used to quickly select the beginning of a particular track. With each momentary tap of the Forward Track Select button (right arrows), the next higher track number will be selected as shown on the display panel. Similarly, with each momentary tap the Backward Track Select button (left arrows), the next lower track number will be selected.

**CD PLAY/PAUSE SELECTOR (II)** - During disc play, press this button to temporarily stop play of the disc. Press the button again to resume play of the disc from the point at which it was stopped.



**REPEAT PLAY SELECTOR (RPT)** - During disc play, press this button to repeat the play of the selected track (“RPT” will appear on the display panel). Play of the track will continue to repeat until the button is pressed again.

**SHUFFLE PLAY SELECTOR (SHF)** - During disc play, press this button to play the tracks on the disc in a random shuffled order (“SHF” will appear on the display panel). The Shuffle Play mode can be cancelled by pressing the button again.

**TRACK SCAN (SCN)** - During disc play, press this button to play the first 10 seconds of each track on the disc (“SCN” will appear on the display panel). When a desired track is reached, press the Scan button again to cancel the function and play of the selected track will continue.

**DISC EJECT (UP ARROW)** - Disc play is stopped, the disc is ejected and the unit will change to radio operation by pressing this button.

**TIME/FREQUENCY SELECTOR (T/F)** - This unit can be set so that either the clock time or radio frequency/CD player functions will normally appear on the display panel. Pressing the Time/Frequency Selector button when the radio frequency or CD player track indication is shown will change the display to show the time. Pressing the Time/Frequency Selector button will change the display to show the radio frequency/CD player indication.

**FRONT PANEL RELEASE BUTTON** - This button is used to release the mechanism that holds the front panel to the chassis. To detach the front panel, press the button so that the left side of the panel is released. Grasp the released side and pull it off the chassis. To re-attach the panel, position the right side of the panel in place first and then press the left side of the panel until the mechanism locks it into place.



# Water Systems

## Section 6

<b>WATER SYSTEMS - INTRODUCTION</b> .....	<b>213</b>
<b>MONITOR PANEL (WATER TANK)</b> .....	<b>214</b>
<b>SERVICE CENTER</b> .....	<b>214</b>
<b>WATER TANK - FRESH FILL</b> .....	<b>215</b>
<b>WATER TANK - FRESH GRAVITY FILL</b> .....	<b>216</b>
<b>WATER - CITY HOOK-UP</b> .....	<b>216</b>
<b>WATER PUMP</b> .....	<b>217</b>
Troubleshooting.....	217
<b>WATER FILTER - FAUCET</b> .....	<b>219</b>
<b>WATER SYSTEM</b> .....	<b>219</b>
Troubleshooting.....	219
Faucet Screens.....	220
Disinfecting Fresh Water .....	220
<b>WASTE WATER SYSTEM</b> .....	<b>221</b>
Proper Waste Disposal .....	221
What to Put in Holding Tanks .....	222
Waste Drain & Sewage Tanks .....	222
Black Tank Flush.....	223
Gravity Waste Drain Hose .....	223
Gravity Drain Hose Dumping.....	224
Pressure Pump Dumping (Opt) .....	225
<b>TOILET</b> .....	<b>227</b>
Operation .....	227
Cleaning .....	228
Maintenance.....	228
<b>TOILET - REAR BATH (OPT)</b> .....	<b>228</b>
Operating Instructions .....	228
Troubleshooting.....	228
Cleaning .....	229
<b>DRAIN TRAPS &amp; AUTO VENTS</b> .....	<b>229</b>
<b>COLD WEATHER USE</b> .....	<b>229</b>
<b>STORAGE - COLD WEATHER</b> .....	<b>230</b>
<b>WINTERIZING</b> .....	<b>231</b>
Using Air Pressure.....	231
Using Nontoxic Antifreeze .....	232
Using Prevent-A-Freeze System (Opt) .....	233



## WATER SYSTEMS - INTRODUCTION

This section contains information and knowledge for the operation and care of the various water systems found in the motorhome. The motorhome is equipped with a fresh water system and a waste water system. Optional water equipment will also be discussed, so not all information may be applicable to the motorhome. More detailed information with CAUTION or WARNING instructions for the various equipment, other than what is found in this section, can be found in the manufacturer's manual in the owner information box.

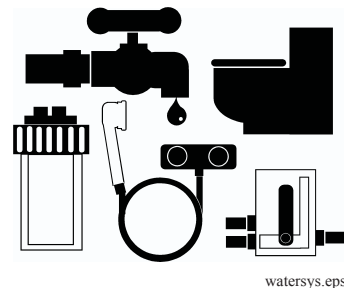

It is hard to imagine how much water is used by the average person everyday. Newcomers to a self-contained motorhome soon discover water does not last very long unless consumption is drastically reduced. For example, less water can be used for showering if the shower is turned off while soaping down, then turned back on to rinse. This way a good shower uses a couple gallons of water or less. There is plenty of water to meet personal needs once habits are adjusted.

**Fresh Water System:** The fresh water system consists of: fresh water tank, water pump, gravity fill connection, water filters and a city/fresh water connection.

Blue tubing is used for all cold water lines throughout the motorhome. Red tubing is used for all hot water lines throughout the motorhome.

Use a water hose that is marked for potable water use only. Care of the hose is a must. **After each use, drain the water hose and coil the hose neatly. Attach the ends together to keep dirt, debris and insects out of the hose.**

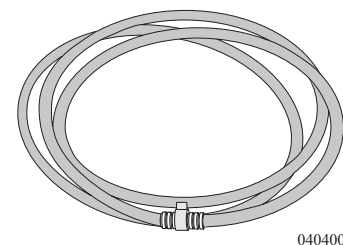

If the motorhome has the optional electric hose reel, the hose will be included. The hose should be coiled on the reel after each use.

**Waste Water System:** The waste water system consists of: a waste holding tank (grey water), a sewage holding tank (black water), flush system, toilet and drains.

**WARNING: Water is electrically conductive. Do not use any electrically powered item or electrical outlet that may be exposed to a water source, such use can result in a serious shock causing injury or death.**

## MONITOR PANEL (WATER TANK)

The motorhome is equipped with a monitor panel to aide in managing the storage tanks. The monitor panel will be located in a main Status Monitor Panel in the hallway area. The switch marked **TEST** is a momentary switch that requires being held down while testing the level of the storage tanks. Read the scale for the desired storage tank that is to be monitored. Each scale uses colored lights along with a corresponding scale reading. The lights and scale indications are as follows:

### LP Tank and Fresh Tank

- Red = Empty
- Orange = 1/3 Full
- Yellow = 2/3 Full
- Green = Full

### Waste Holding Tanks

- Green = Empty
- Yellow = 1/3 Full
- Orange = 2/3 Full
- Red = Full

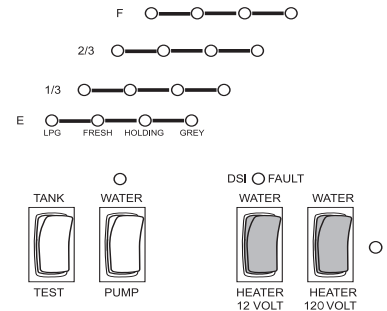

060158p

## SERVICE CENTER

The service center water controls are used for performing all tasks pertaining to water usage in the motorhome. Service center is located in an outside compartment of the motorhome.

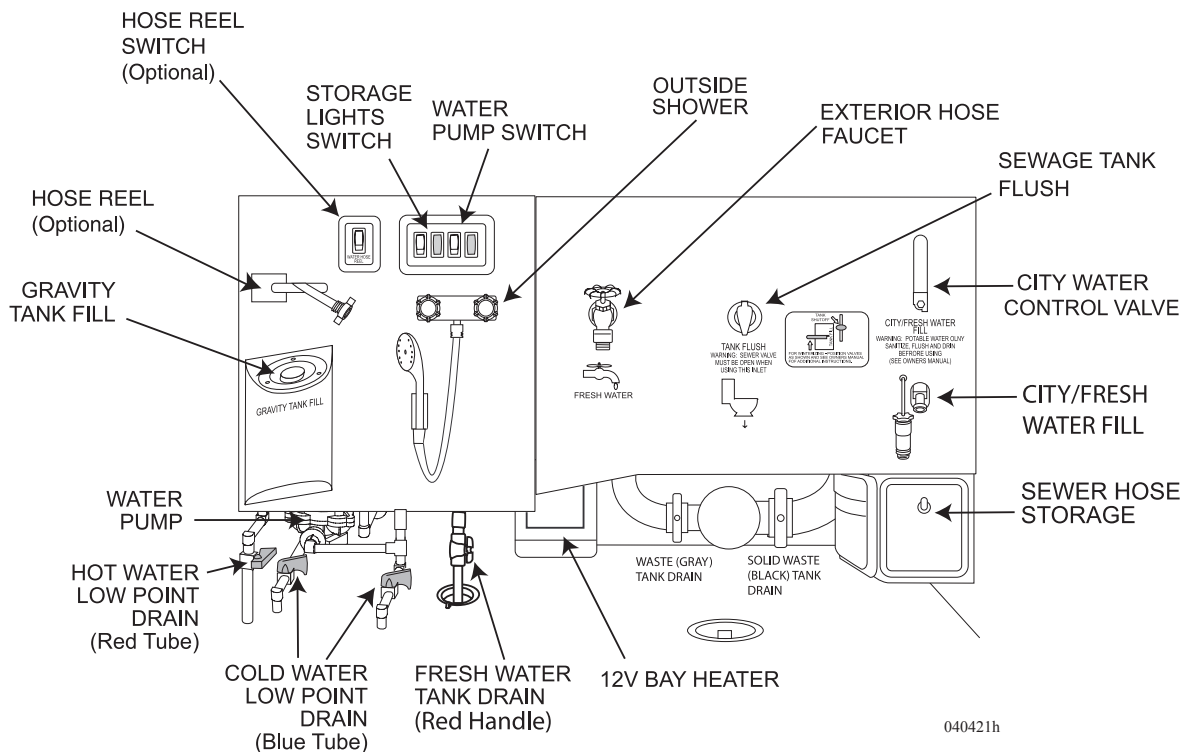

040421h

**WATER TANK - FRESH FILL**

1. If the motorhome has the optional hose reel, pull hose out.  
Connect the pressure regulator and hose to water source and go to step 4. Arrow on pressure regulator must be pointed toward reel. If motorhome does not have the reel, proceed with step 2.
2. Connect the hose labeled for potable water to the water source.  
Install the provided pressure regulator on the fill valve. Arrow on regulator must be pointed toward valve.
3. Connect the water hose to the pressure regulator inlet.
4. Check to make sure the fresh water tank drain valve, located on roadside in the service center, is in the closed position.
5. The fill valve should be in the Fresh Water Tank position.
6. Turn on the water at the water source. The water should be audible as the fresh water tank fills.
7. When the fresh tank is full, water will come out an overflow hose underneath the motorhome.
8. Turn off water supply as quickly as possible.
9. Return fill valve handle to city water.
10. Unhook hose from water source. If applicable, remove pressure regulator from water source and activate hose reel switch to coil hose on the reel.

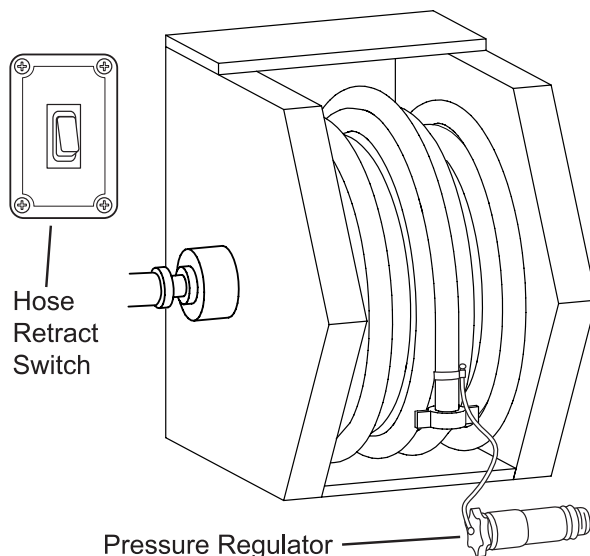
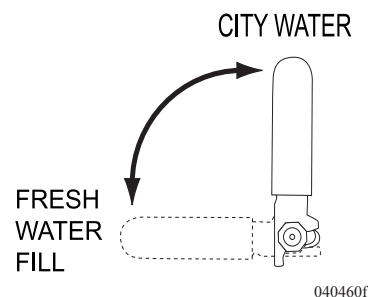
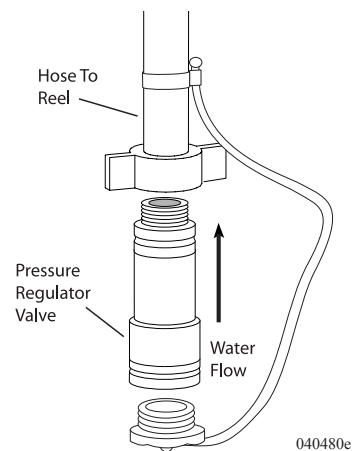

## WATER TANK - FRESH GRAVITY FILL

The gravity fill inlet allows fluids to be introduced directly into the fresh water tank. Water can be poured directly from a container into the fresh water tank. The gravity fill inlet can be used to pour disinfecting solution into the fresh water tank or when using potable RV antifreeze to winterize the fresh water system. Use only potable water sources, solutions and delivery systems when using the gravity fill inlet.

### Filling the Tank:

1. Unscrew fill cap taking care to keep cap and inlet clean.
2. Insert potable water hose into inlet.
3. Fill tank until water overflows from inlet.

**NOTE:** When filling tank do not leave hose unattended.

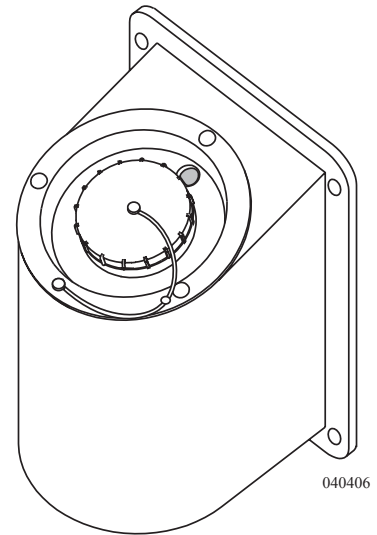

## WATER - CITY HOOK-UP

When connecting the motorhome to fresh water, use a hose manufactured and labeled for potable water to ensure that the hose will not flavor the water.

1. If the motorhome has an optional hose reel, pull hose out. Connect the pressure regulator and hose to water source and go to #4. Arrow on the pressure regulator must be pointed toward reel. If motorhome does not have a reel, proceed with #2.
2. Connect the hose labeled for potable water to the water source. Install the provided pressure regulator on the fill valve. Arrow on regulator must be pointed toward valve.
3. Connect the water hose to the pressure regulator.
4. Valve handle should be in the city water position.
5. Turn on water at water source.
6. The water pump can either be in the OFF position or in the ON position. It will not affect the water pump to leave it on.
7. Open each faucet, one at a time, to rid any trapped air inside the pipes.

**CAUTION:** Some water sources develop high water pressure, particularly in mountainous regions. High water pressure is anything over 55 psi (pounds per square inch). Excessive water pressure may cause leaks in water lines and/or damage the water heater.

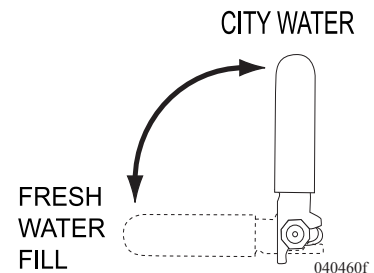
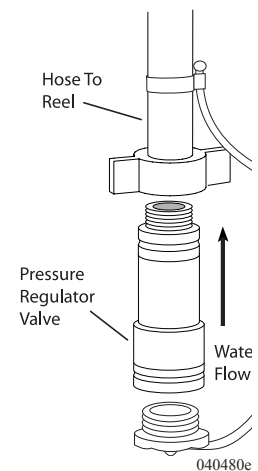



**WATER PUMP**

The water pump pressurizes the fresh water system when not connected to city water. The water pump is totally automatic and self-priming, operating on demand as water is used. The water pump is located in a storage compartment of the motorhome.

**WARNING:** Before leaving the motorhome for extended periods of time (i.e. overnight or longer) be sure that the city water and all water pumps have been turned off. Damage from neglect will be the responsibility of the owner, not the manufacturer.

**NOTE:** The latching controller is located next to the water pump.

The water pump can be operated from the following location:

- Monitor Panel

To turn the water pump on or off:

- Momentarily press the water pump switch. The indicator lamp will illuminate when the water pump is turned on.

**CAUTION:** Do not continue water pump operation if the fresh water holding tank is empty. Damage to the water pump or electrical supply system may result.

Use the following procedure to operate the water pump after unhooking from the city water supply or after storage:

- Close all drain valves and low point drains.
- Fill the fresh water tank.
- Open the hot and cold water valves of each faucet.
- Turn the water pump on. Wait for the water lines and the hot water tank to fill.
- Close each faucet when it delivers a steady stream of water (cold water faucets first).

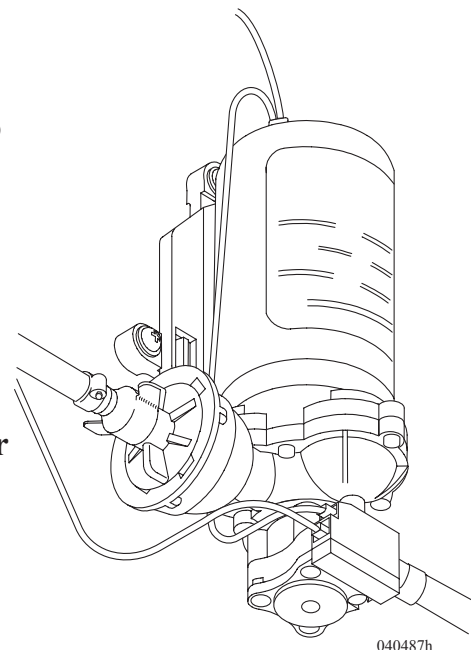

Red  
Indicator Light



WATER

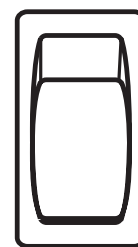

PUMP

Water Pump Switch

**Troubleshooting**

Vibration induced by road conditions can cause the plumbing or pump hardware to loosen. Check for system components that are loose. Many symptoms can be resolved by tightening the hardware. Check the following items along with other particulars of the system:

**The water pump will not start/blows the circuit:**

- Check the electrical connections, fuse, breaker, main switch and ground connection.
- Is the motor hot? The thermal breaker may have triggered. It will reset when cool.
- Is the voltage present at the switch? Bypass the pressure switch.
- Does the pump operate? Check the charging system for correct voltage and check the pump for the proper ground connection.
- Look for an open or grounded circuit or motor.
- Check for seized or locked diaphragm assembly (water frozen).

**The water pump will not prime/sputters: (No discharge/motor runs):**

- Is the strainer clogged with debris?
- Is there water in the tank or has air collected in the hot water heater?
- Is the inlet tubing/plumbing sucking in air at plumbing connections (vacuum leak)?
- Check for proper voltage with the pump operating.
- Look for debris in the pump inlet/outlet valves or dry/swollen valves.
- Check the pump housing for cracks or loose drive assembly screws.

**The water pump will not shut-off or runs when the faucet is closed:**

- Make sure the fresh water tank fill valve is completely closed.
- Check output side (pressure) plumbing for leaks and **inspect** for a leaky toilet or valves.
- Look for loose drive assembly or pump head screws.
- Are the valves or the internal check valve held open by debris or is the rubber swollen?

**The water pump is noisy or rough in operation:**

- Check for plumbing which may have vibrated loose.
- Does the mounting surface multiply noise (flexible)?
- Check for mounting feet that are loose or compressed too tight.
- Look for loose pump head to motor screws (three long screws).
- Is the motor with the pump head removed? Is noise coming from the motor or pump head?

**The water pump is rapid cycling:**

- Look for restrictive plumbing/flow restrictors in the faucets or shower heads.

## WATER FILTER - FAUCET

The motorhome is shipped with a diverter hose in place of the in-line faucet water filter. For winterization purposes the diverter hose will have to be installed in place of the filter. To initially install a water filter or to replace a water filter, use the procedure as follows:

- Locate the water filter diverter hose under the galley sink area.
- Remove the top and bottom fittings from either the hose or filter.
- Connect top and bottom fittings to the filter to purify the system.
- Store diverter hose for use when winterizing the water system.

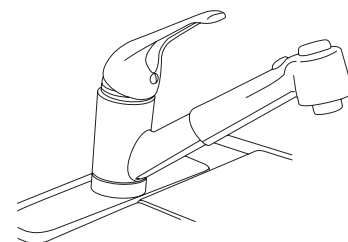

040574b

A fresh replacement cartridge is needed when the flow of water from the faucet becomes slow. The life of the filter depends upon incoming water conditions and water consumption.

As water passes through the water filter, dirt particles are trapped in the tiny pores of the micro-pure coating on the filtering element inside the cartridge. As the cartridge removes the impurities from the water, its microscopic pores slowly permeate and the amount of water flowing from the cartridge gradually decreases.

When the flow of water from the water filter becomes too slow for convenience it requires servicing. If the cartridge is not changed the flow will eventually stop. Even when a decreasing water flow does not demand the cartridge be replaced, it is recommended the filter be replaced at least once a year for continued reliable performance from the purification system.

**NOTE: Change the filter at least once a year.**

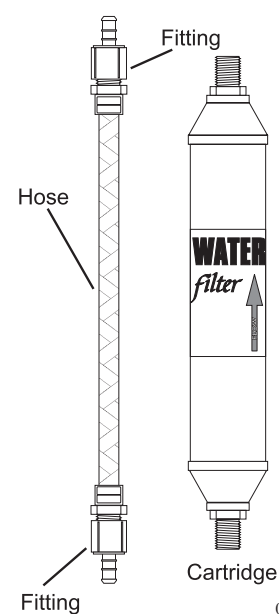

040383

## WATER SYSTEM - Troubleshooting

Water system problems and leaks usually fall into two categories: system problems and problems caused by improper use or lack of attention. These problems usually stem from improper winterizing, poor maintenance, road vibration and campsite water pressure variations.

Check all plumbing connections for leaks at least once a year. If the water pump runs when a faucet is not open, check for a water leak. Be sure the tank drain valves are closed. If the system continues to leak take the motorhome to an authorized dealer for service.

## Faucet Screens

Fresh water sources will vary by location. Build up lime deposits or debris on the faucet screens will restrict or plug the flow of water coming from the faucets. All faucet screens should be checked and cleaned every two weeks of use.

- Faucet screens are normally located on the outlet side of the faucet and held in place with a threaded collar.
- Remove screen from faucet.
- Clean screen using a small soft brush and a de-liming solution.

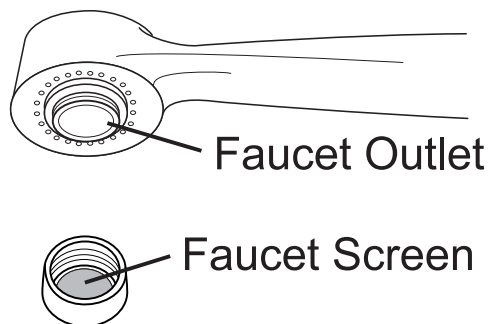

040472c

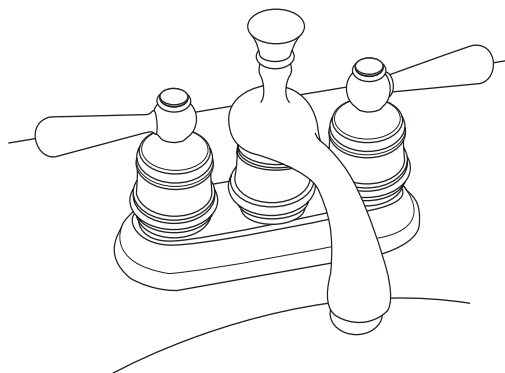

040574

- Reinstall screen and check water flow.

---

## Disinfecting Fresh Water

Disinfecting the water system with chlorine bleach (superchlorination) protects the drinking water from bacterial or viral contamination that may come from any common water source.

### Disinfect the Water System:

- If the motorhome is new.
- If the motorhome has not been used in a long time.
- Every **three** months.

**NOTE: Use the gravity fill to perform this task. Remove cap from the gravity fill. Add the solution to the fresh water tank. When finished, secure the gravity feed cap.**

### Use following procedure to disinfect water system:

- Replace the faucet water filter with the diverter hose (see "Faucet Water Filter").
- Prepare a household chlorine bleach solution using 1 gallon water and 1/4 cup of chlorine bleach. Use 1 gallon of solution for every 15 gallons of tank capacity. Example: Add 2-2/3 gallons solution to a 40 gallon tank. Add 4-2/3 gallons solution to a 70 gallon tank. Add 6-2/3 gallons to 100 gallon tank. This mixture puts a 50 ppm (parts per million) residual in the water system, and acts as a quick-kill dosage for harmful bacteria, viruses and slime-forming organisms. Concentrations higher than 50 ppm may damage the water lines and/or tanks.
- Turn the water pump OFF.

- Drain the fresh water tank. Water tank drain is located at the bottom of the tank. Close the drain and pour the solution into the fresh water tank using the gravity fill and a funnel.
- Turn the water pump ON. Open each faucet, in turn, and run the water until you smell a distinct chlorine bleach odor. Do not forget the hot water, tub and shower faucets.
- Allow the system to stand for four hours.
- Drain the system and flush with fresh water. The water tank and low point drains are located in the outside water control compartment. Flush with fresh water repeatedly, until the water system no longer smells or tastes like chlorine bleach.
- Install new faucet water filter.

---

## **WASTE WATER SYSTEM - *Proper Waste Disposal***

Most State Parks have strict regulations about discharging wastes except into authorized disposal systems. Dumping raw sewage from toilet holding tanks, except at authorized dumping stations, is universally prohibited.

Most National, State and private parks have either a central dump facility or campsite hook-up for sewage. Many of the modern rest areas along the interstate now have dump stations available. You will find a list of dumping stations from coast to coast in Woodall's Campground Directory, Trailer Life's RV Campgrounds and Services Directory, Rand McNally's Campground and Trailer Park Guide, Good Sam Park Director (Good Sam Club), and other similar publications. Some major oil companies offer dump facilities at selected stations. With a little planning, there are few inconveniences in proper and legal disposal of holding tank waste.

- Do not use strong or full strength detergents to deodorize and disinfect. Use odor control chemicals made especially for holding tanks.
- Do not put automotive antifreeze, ammonia, alcohol or acetone in holding tanks. Some chemicals will dissolve plastic.
- Do not put large table scraps in the tanks. They could be stuck in or damage the valve seals.
- Do not flush facial tissues, sanitary napkins or other non-dissolving items into the system. Chemically treated for strength, the tissue will not dissolve like toilet paper. Special holding tank tissue is available at most RV supply stores. White toilet paper dissolves faster than colored paper.

**NOTE: Never dispose of sanitary supplies or other non-dissolving items into the system. Facial tissue, wet strength tissue, paper towels or an excessive amount of toilet tissue can create clogging in the holding tank system.**

**CAUTION: Do not use any products that contain petroleum distillate or ammonia in place of RV odor controlling chemicals. Petroleum distillate or ammonia will damage the ABS plastic holding tanks and seals.**

## ***What to Put in Holding Tanks***

**Black Tank:** Before initially operating the toilet, treat the sewage holding tank with a pre-charge of water mixed with an odor-controlling chemical (available at most RV supply stores). First, add about three gallons of water to the holding tank. Then mix the chemicals, according to the manufacturer instructions, with about one gallon of water. Pour mixture through toilet to the holding tank. Be careful not to spill the chemical on your hands, clothing, toilet bowl or carpet. Hot weather conditions may require adjusting the amount of chemical used to control odor. Repeat the chemical pre-charge to the holding tank each time the tank is cycled.

**WARNING: Most chemical mixtures for holding tank odor control are poisonous. Follow the product manufacturer's directions and warnings when using holding tank additive. Do not use any products that contain petroleum distillate or ammonia in place of RV odor controlling chemical. Petroleum distillate or ammonia will damage the ABS plastic holding tanks and seals.**

**Grey Tank:** The grey water waste tank stores the sink, shower and clothes washer drain water. A reduced mixture of chemicals may help to control odor in the grey tank.

Ensure that there is enough liquid in the holding tanks prior to dumping the waste holding tanks to provide a smooth flow through the valve, drain pipe and drain hose. Empty the waste holding tanks weekly to prevent stagnation and overfilling.

---

## ***Waste Drain & Sewage Tanks***

The waste drain system provides adequate and safe storage and/or discharge of waste materials. The drain system uses ABS plastic piping and fittings connected to sinks, shower, toilet and holding tanks draining to an outside termination. The motorhome should be reasonably level for optimum operation of the systems. The wastewater holding system consists of a wastewater holding tank (grey tank). The grey water tank stores the sink, shower and clothes washer drain water. A sewage holding tank (black tank) stores waste from the toilet only.

Drain valves and a tank flush system dispose waste through a common termination. Each holding tank has a separate drain valve dumping the waste water (grey water) and sewage (black water) through a common single discharge outlet. The tank drain valves are located in the service center on the roadside of the motorhome. Use the Aladdin system to observe tank levels. When ready to drain the tanks, drain the sewage tank first. Next, flush the black tank with the flush system. Drain the grey water tank. Using this sequence helps flush solids from the sewer hose. When traveling, it is recommend both holding tanks be empty or less than half full.

**Black Tank Flush**

The motorhome comes equipped with a power flush system to aid in cleaning the holding tank. The power flush nozzle, located in the black tank, helps reduce solid build-up. Use the tank flush each drain cycle. Failure to thoroughly rinse the tank each drain cycle may result in solids accumulating and a clogged spray nozzle.

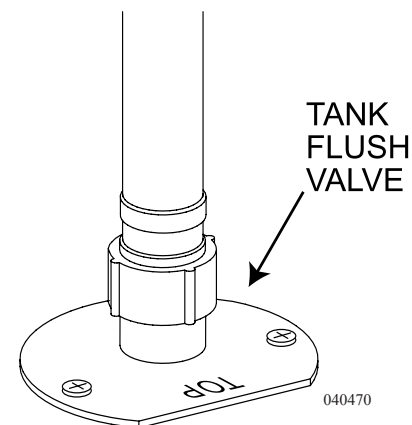
**Gravity Waste Drain Hose**

A flexible three inch sewer hose attaches between the termination drain and the shore facility. Sewer hoses usually come in 10 or 20 foot lengths. The shore fitting for the sewer hose may be three or four inch pipe, which could be male or female thread. Another possibility may be a four inch pipe, with no threads, covered by a metal plate. There are many configurations. Different style adapters are available to fit most configurations. Hose ladders may also be purchased to support the hose.

It is important that the hose remains secure. Always tighten clamps and restraining devices before use. Lay the hose inline between the termination outlet and the shore fitting. Restrain the hose to prevent movement during use. Wear protective and/or disposable gloves when handling the sewer hose.

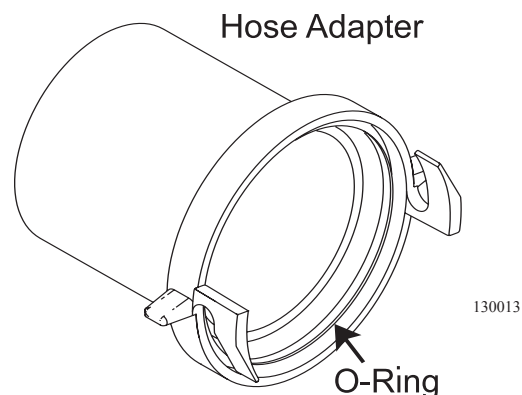
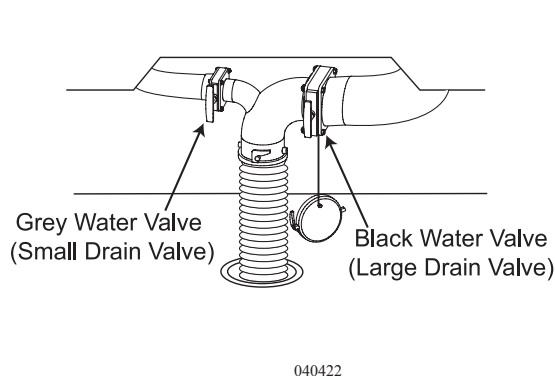
**To Attach the Hose:**

1. Remove termination cap. Align coupler tangs with termination tabs. Twist coupler clockwise 90° locking coupler to termination outlet.
2. Attach the other end of the hose to the drain service. Restrain hose to prevent movement during use.
3. Open the (small) grey water valve.



**NOTE:** Close the grey water valve 24 hours prior to departing to allow the tank to fill with liquid to help in the dumping process.

The (large) black water valve remains closed until the tank is full or until time of departure. This will help prevent accumulation of solids. Use the outside faucet or shower attachment for washing or rinsing.

**NOTE:** Lubricate the O-ring on the sewer hose adapter periodically with silicone spray. Use care when connecting the sewer hose adapter to the termination outlet in cold weather.

### Gravity Drain Hose Dumping

1. Attach the gravity hose to terminal drain and shore facility.
2. Close the grey water holding tank valve. Fill the grey tank to at least 50% by running water in the shower or sinks.
3. Use the monitor panel to observe tank fluid levels. When the grey tank is 50% full stop filling the tank.
4. Open the black water valve. Allow the black tank to drain.
5. Use the tank flush system.
6. Connect a non-potable water hose, with pressure regulator, to the flush system fitting located in the service center.
7. Turn on the faucet allowing water to rinse the black tank at least three minutes. Never operate the system unattended. Ensure the water flows freely through the drain hose.
8. When completed turn off the faucet and close the black water valve.
9. Open the grey water valve. The water in the grey tank flushes any remaining solids from the hose. With the grey water valve open, run two gallons of water down any drain to flush the grey tank. The grey valve remains open until the next drain cycle or departure.

**WARNING:** Never operate the flush system unattended. Flooding may occur. Use the tank flush system each time the holding tanks are cycled. Failure to routinely use the flush system will result in a clogged spray nozzle. Turn off the water supply when finished flushing the tank.

10. If preparing for travel, close both the valves. Undo any restraining devices from the hose. Disconnect the hose from the termination outlet by rotating the fitting counterclockwise 90°.
11. Raise hose and drain using hand over hand method working hose towards shore fitting. Rinse the hose with outside facility and repeat the hose drain process.

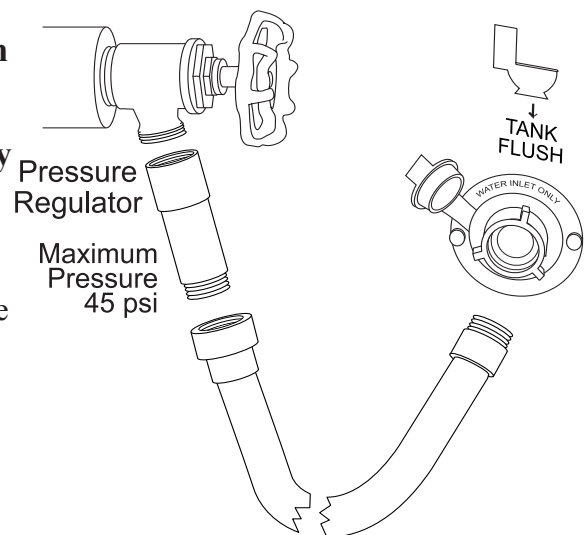

040416

**NOTE:** Dump the black tank before driving.



12. Remove the hose from shore fitting. Install hose in carrier and lock door. Secure the termination cap (required by law in some states).
13. If desired, add chemicals to the tanks to control odor. Follow the chemical manufacturer's directions.

### **Pressure Pump Dumping (Optional)**

The holding tank management system is a closed loop system using a 12 gallon per minute macerator pump. Using the pressure pump to empty the holding tanks can be accomplished in a matter of minutes. It is not necessary to empty the black tank before the grey tank unless desiring to do so. The pressure pump allows for dumping the holding tanks into a shore drain that is at any height. Use the monitor panel to observe tank fluid levels.

#### **Prepare the Pump for Use:**

- Make sure the black tank (solid waste water) and grey tank (liquid waste water) valves are closed.
- Remove the terminal outlet drain cap. Align pump inlet hose coupler tangs with the terminal tabs. Twist the coupler clockwise to lock it to the terminal outlet.
- Remove the drip cap from the outlet of the pump discharge nozzle.
- Install discharge nozzle to the shore drain. The nozzle adapters are threaded to fit most shore drain pipes.
- Turn on the chassis battery disconnect. Pump operates on 12 Volts from the chassis battery.
- If desired, the grey tank (liquid waste water) valve can be opened while the discharge nozzle is attached to the shore drain. Water used from the sinks, shower and clothes washer will drain through the bypass hose into the shore drain.

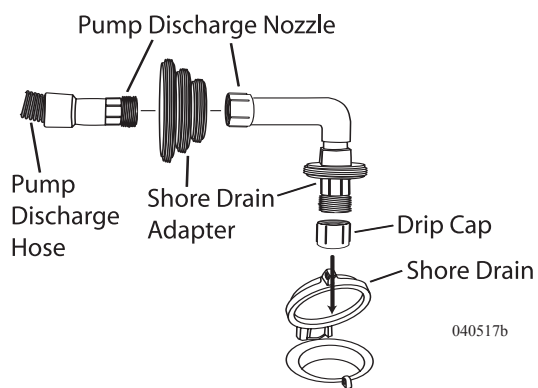
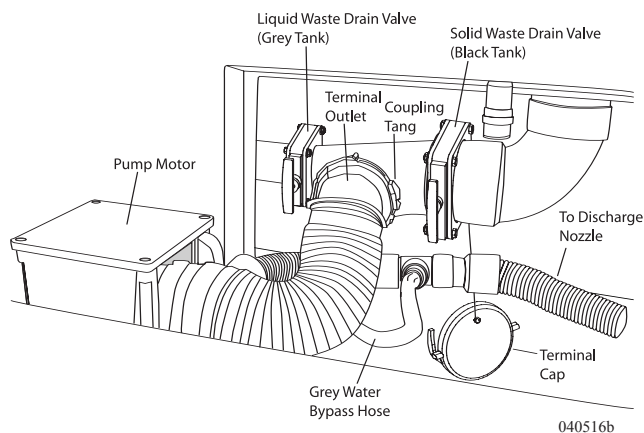

#### **Prepare the Pump for Travel:**

- Make sure the black and grey tank valves are closed.
- Turn the pump ON for a few seconds to clear any water from the pump inlet hose. Turn the pump OFF.
- Remove pump discharge nozzle from the shore drain. Install the drip cap on the nozzle (required by law in some states).
- Store nozzle and pump discharge hose.
- If desired, add chemicals to the holding tanks to control odor. Follow the chemical manufacturer's directions.

**To Empty the Grey Tank (Liquid Waste Water):**

- Prepare the pump for use if not already done.
- If applicable, close the black tank (solid waste water) valve.
- Open the grey tank drain valve.
- Turn the pump ON and allow the grey tank to empty. The pump will run faster when the tank is empty. Turn the pump OFF.
- Close the grey tank drain valve.
- If applicable, the black tank (solid waste water) can be emptied at this time.
- Prepare the pump for travel as desired.

**To Empty the Black Tank (Solid Waste Water):**

- Prepare the pump for use if not already done.
- If applicable, close the grey tank (liquid waste water) valve.
- Open the black tank drain valve.
- Turn the pump ON and allow the black tank to empty. The pump will run faster when the tank is empty. Turn the pump OFF.
- Use the black tank flush system. Connect a non-potable water hose, with pressure regulator, to the water source. Connect the other end of the water hose to the fitting located in the service center.

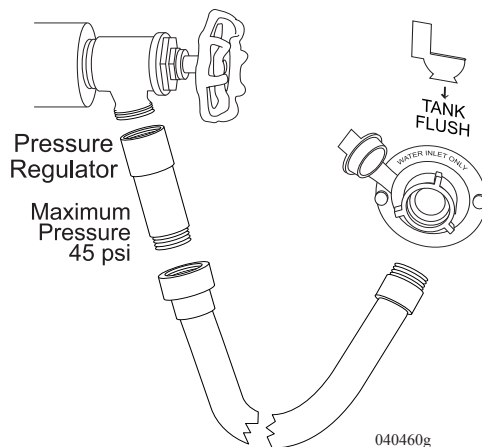

- Turn on the water source and allow the water to rinse the black tank at least three minutes.
- Turn the water off, disconnect the hose and pressure regulator. Store the hose and regulator for future use.
- Turn the pump ON and allow the black tank to empty. Turn the pump OFF and close the black tank drain valve.
- If applicable, the grey tank (liquid waste water) can be emptied at this time.
- Prepare the pump for travel as desired.

**TOILET - Operation**

The toilet operates from either the fresh water tank or city water supply. The water pump must be turned on or the city water connected. The toilet flushes directly into a sewage holding tank (black water).

**NOTE:** To prevent accumulation of solids below toilet, add several gallons of water to the holding tank before use.

**CAUTION:** Most chemical mixtures for holding tank odor control are poisonous. Follow the product manufacturer's directions and warnings when using any holding tank additive.

- Using foot, lift up the flush lever to add water to the bowl. Generally, more water is required only when flushing solids.
- To flush the toilet, push the lever all the way down until the sewage leaves the toilet.

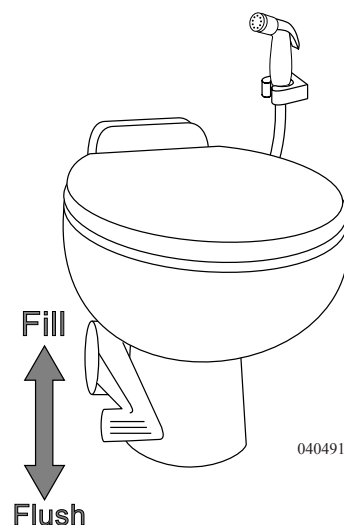

Water flow pressures vary at different locations; therefore, holding the flush lever down for several seconds may be required. Release the flush lever by allowing it to snap back, which permits positive sealing around the flush ball. A small amount of water should remain in bowl.

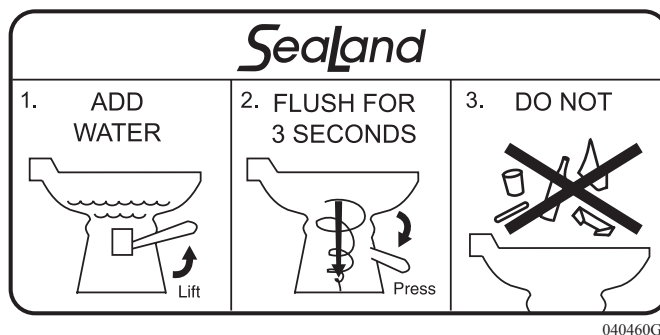

**NOTE:** Holding flush lever down longer than necessary results in excessive water usage.

- To operate the remote mounted hose sprayer, hold the flush lever up or push the flush lever down. Press the handle on the sprayer to wash trim and bowl.

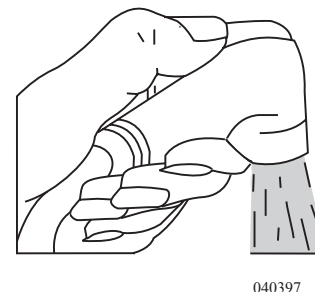

**NOTE:** Never dispose of sanitary supplies or other non-dissolving items into the toilet. Facial tissue, wet strengths issue, paper towels or an excessive amount of toilet tissue can clog the tank or termination valve.

## **Cleaning**

The toilet should be cleaned regularly for maximum sanitation and operational efficiency. Clean the toilet bowl with a mild bathroom cleaner. Do not use chlorine or caustic chemicals, such as drain opening types, as they will damage the seals.

Clean out the system by flushing several gallons of fresh water through with one cup of dry laundry detergent. Add odor control deodorant, in the amount specified for your holding tank capacity, after cleaning and every few days during use.

---

## **Maintenance**

To find leaks, check behind or under toilet. Take four or five sheets of toilet tissue and wipe all the seams and water line connections. Start at the top of the unit and work downward. When the tissue comes in contact with leaking water it will immediately change texture.

**NOTE: If the motorhome is in storage for six months it is a good idea to spray silicone on the toilet valve and work it back and forth. Perform this maintenance monthly (silicone will evaporate in about 30 days).**

---

## **TOILET - REAR BATH - Operating Instructions (Not on All Units)**

The toilet is an electric macerating toilet. To avoid damage, only flush organic material and toilet paper. Toilet requires a 12-VDC/40 amp dedicated circuit with an 8-gauge wire and 40 amp fuse between the battery and a terminal located near the toilet.

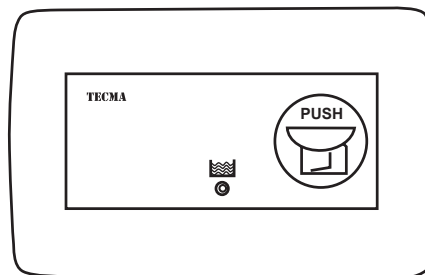

040535

**Flush Cycle:** After button is pushed bowl will begin to fill with water. Contents of the bowl will then be evacuated. A dry bowl will appear white while a short flushing of the internal mechanism occurs. Bowl refill will automatically begin after several seconds. Once refill is complete, toilet is ready to flush again as needed.

---

## **Troubleshooting**

**Wiring:** The toilet is wired to a 40 Amp Fuse in the house distribution panel.

### **Leaks:**

- Back of toilet: check water supply line connection.
- Poor flush: A good flush should be obtained within 2 to 3 seconds. If problem persists remove the water supply line and check flow rate. The flow rate should be at least ten quarts (9.5 liters) per minute.
- Bowl will not hold water: Check for foreign material in valve blade groove in the flush drain.

**NOTE: Most chemical mixtures for holding tank odor control are poisonous. Follow the product manufacturer's directions and warnings when using any holding tank additive.**

## Cleaning

The toilet should be cleaned regularly for maximum sanitation and operational efficiency. Clean the toilet bowl with a mild bathroom cleaner. Do not use chlorine or caustic chemicals, such as drain opening types, as they will damage the seals.

Clean out the system by flushing several gallons of fresh water through with one cup of dry laundry detergent. Add odor control deodorant, in the amount specified for your holding tank capacity, after cleaning and every few days during use.

## DRAIN TRAPS & AUTO VENTS

Sinks, shower and clothes washer drains incorporate a water trap or "P-trap" and auto vents to prevent waste water holding tank odor from entering the motorhome. These P-traps are usually within 54" of a vent tee. These traps must have water in them to block odors. During storage water can evaporate and allow odor into motorhome. If odor is detected run water into sinks, shower and clothes washer to fill drain traps. The auto vent by design is to assist in the flow of water in the drain lines. They enable a smooth flow of water in the drain without creating a vacuum.

If the auto vent is stuck in the open position, grey odors may enter the motorhome. Auto vents double as "clean outs" in case the line has to be "snaked" out.

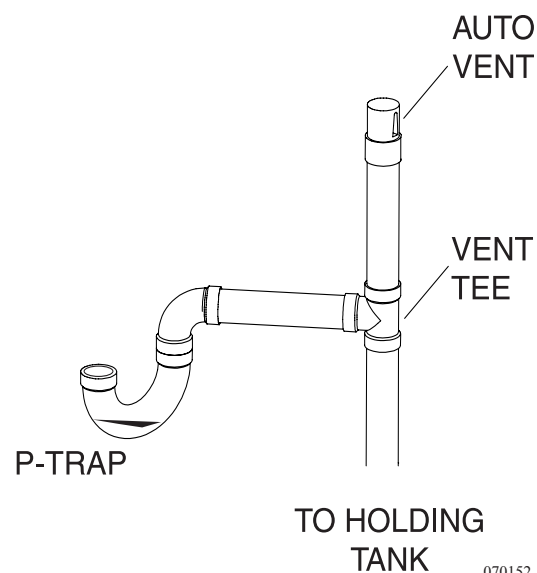

**NOTE: Most chemical mixtures for holding tank odor control are poisonous. Follow the product manufacturer's directions and warnings when using any holding tank additive.**

**NOTE: During cold weather antifreeze must be added to the drain traps.**

## COLD WEATHER USE

The motorhome is not designed for extended use in below freezing (32°F/0°C) weather. There are precautionary measures that can be taken for extended cold weather use.

Interior water lines, fixtures, and drains above the floor are normally protected from moderate freezing temperatures as long as the furnace is operating.

Cold temperatures can adversely affect water systems below the floor level because the furnace heat does not provide heat to these components.

A bay heater with a “Snap Disc” thermostat is used to heat the water control bay.

**System Operation:**

1. Systems heat switch is turned ON to applying power to the snap disc thermostat and bay heater.
2. When the bay temperature reaches 40° F +/-6° F the snap disc thermostat will close applying power to the bay heater and the systems heat active indicator light will be lit. The twelve-volt heater will continue to operate until the bay temperature reaches 55° F +/- 6° F. The indicator light will then turn OFF.

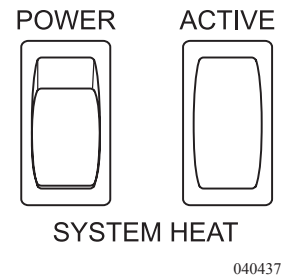

Exposed drains and water lines may freeze quickly in below freezing temperatures. If, by the way of prior experience, there is doubt as to what temperature the motorhome water system will tolerate and the water system will not be used, winterize the water system using potable antifreeze. When the tanks are dumped, additional potable antifreeze will need to be added to the storage tanks.

**WARNING:** The battery disconnect switches must be turned off if the motorhome is left for an extended period of time (2hrs). The battery cut-off switch does not control the bay heater circuitry.

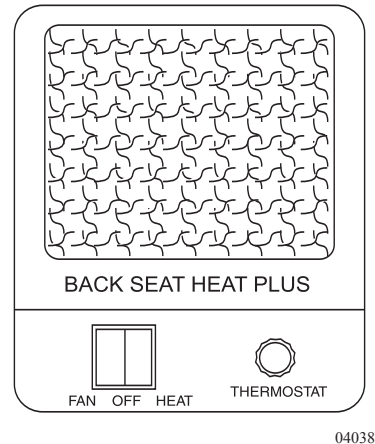

**NOTE:** The heat system will quickly drain the motorhome batteries when not connected to shore power or operating from the generator. Only use the heat functions when hooked to shore power or operating from the generator.

---

## STORAGE - COLD WEATHER

If the motorhome is stored where freezing temperatures may occur, drain the domestic fresh water loop completely of water. The method chosen to winterize the motorhome and water lines is up to the motorhome owner. The lines can be air blown to remove standing water or the lines can be filled with an approved FDA RV antifreeze. Either way, all interior and exterior faucets need to be opened and closed, one at a time, to be checked. All low point drains should be opened and the holding tanks emptied.

**NOTE:** Icemakers (if applicable), water filters, washer/dryer (if applicable) and water heaters all use domestic water and should be drained and stored in accordance with the manufacturer’s recommendation for winterization.

---

**WINTERIZING - Using Air Pressure**

To use air pressure to winterize the motorhome you will need access to an air compressor and an adapter to connect the air line to the water system. Adapters can be found at any RV supply store. When hooked to the water lines the pressure should not exceed 40 psi. Higher pressure can damage the lines.

1. Replace the faucet water filter with the diverter hose. (See "Faucet Water Filter.")
2. Drain the fresh water tank by opening the valve located at the bottom of the tank. Fresh water tank is in a roadside compartment.
3. Place the water heater by-pass valve to the by-pass position. By-pass valve is located at the back of the water heater. Open the water heater drain plug. Water heater drain plug is located at the front of water heater behind the Burner Compartment door.
4. Open the low point drains by turning knobs to open position. Low point drains are in a curbside compartment. The open low point drains will clear water out of the hot and cold water lines. Leave the low-point valves open until the motorhome is used again.
5. Let all the water drain.
6. Turn the water pump on and allow it to run so that all the water is cleared out of the pump and lines. Turn the water pump off.
7. After the water lines are drained, hook an air hose to the city/fresh water fill connection located on the water service center. Blow out the water lines until no further water can be seen coming out of the drain lines. Do not exceed 40 psi in the water lines and faucets.
8. Open all faucets (including the outside spigot), one at a time while the air is on, to clear water from the faucet supply lines. Do not forget to drain the shower.
9. If applicable, winterize the washer/dryer. (See "Winterizing the Washer/Dryer" in Section 4.)
10. While the air is on, flush the toilet repeatedly until the water stops running.
11. Unhook the air hose and close the city/fresh water fill connection.
12. Drain the holding tanks. Close valve when tanks have drained.
13. One gallon of RV antifreeze is needed to protect various water drain lines in the motorhome. Pour 1 pint into both the kitchen and bath shower drains. Pour 2 pints into the bath sink drain, with some of the antifreeze going into grey tank to protect the drain valve. Pour another 3½ pints into the toilet. Flush the toilet and allow the antifreeze to run into the black tank to protect the valve located there. Pour the last pint of antifreeze into the toilet after you have released the flush control. Use a soft cloth to wipe out the sinks and shower (after the antifreeze is poured in) to protect the surfaces from stains.
14. Leave the low-point drains open until the motorhome is used again.

**WARNING**

**When draining the low water drain lines and the water heater, ensure the water is not hot. Hot water from the lines can burn or injure skin.  
sure the water is not hot. Hot water from the lines can burn or injure skin.**



---

## Using Non Toxic Antifreeze

Ten gallons of FDA approved RV antifreeze will be required to winterize the motorhome.

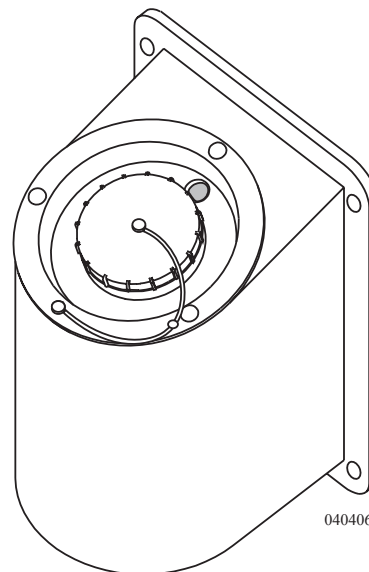

1. Empty and flush the holding tanks.
2. Replace the faucet water filter with the diverter hose (see “Faucet Water Filter”).
3. Remove the drain plug from the front of the water heater. At the back of the water heater, turn the water heater bypass valve (not on all units) to Bypass.
4. Open all faucets. In the water service compartment, open the low point drains and drain valve for the fresh water tank. Operate the water pump to clear water pump of water.
5. Close all faucets, drain valves and low point drains.
6. Pour the antifreeze into the fresh water tank using the fresh water gravity fill.
7. Turn on the water pump and operate each faucet (hot and cold valves) individually until a small amount of antifreeze is present.
8. Close off the faucets.
9. Open the shower faucets and toilet valve to allow a small amount of antifreeze to run into the holding tanks.
10. Use a soft cloth to wipe out the sinks and shower to protect surfaces from antifreeze stains.
11. Open the exterior faucet using the same procedure as the interior faucets.
12. If the motorhome is equipped with an icemaker in the refrigerator, remove the 3/4” fitting and flush antifreeze through the water line.
13. Disconnect the power supply line affecting water pump operation.

**De-winterization:** For de-winterization, drain off the fresh tank and fill the fresh tank with water. Reconnect the power supply line for the water pump. Turn water pump on and operate all faucets, one at a time, until clear water is present. If applicable, cycle icemaker several times until fresh water is present and reconnect valve outlet line. Install new water filters and fill water heater with water.

**WARNING:** Use only designed non-toxic RV antifreeze for potable water systems. Automotive antifreeze, if ingested, can cause blindness, deafness or death.

**CAUTION:** Discard the first two trays of ice from the icemaker. They may contain contaminants.

**WARNING:** It is recommended that a qualified RV service technician familiar with motorhomes, such as an authorized dealer, do this procedure.



**Using Prevent-A-Freeze System (Optional)**

Three gallons of FDA RV winterizing antifreeze is needed to fill the storage tank. Keep the storage tank full after each use.

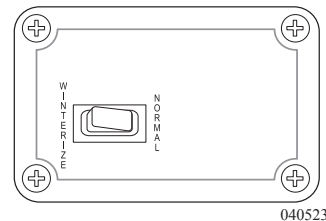

1. **Fill the storage tank with FDA RV winterizing antifreeze. Tank is located in the LP tank bay compartment.**
2. Replace the faucet water filter with the diverter hose (see "Faucet Water Filter").
3. Open all low point drains and drain valves to drain the fresh water tank, water heater tank, and fresh water lines. The fresh water tank drain is located at the bottom of the tank, water heater drain is at the back of the water heater and low point drains are next to the plumbing manifold.
4. Drain the holding tanks. Close valves when tanks have drained.
5. Close all faucets, drain valves and low point drains.
6. Turn the Prevent-A Freeze switch(s) to "WINTERIZE" position. Switch is located on the wall in the bathroom.
7. Turn ON the system water pump and operate each faucet individually until a small amount of antifreeze is present.
8. Close all faucets.
9. Open the shower faucets and toilet valves to allow a small amount of antifreeze to run into the holding tanks.
10. Use a soft cloth to wipe out the sinks and shower to protect surfaces from antifreeze stains.
11. Exterior faucet should be opened and closed using the same procedures as the interior faucets.
12. If applicable winterize the washer/dryer (see "WINTERIZE THE WASHER/DRYER").
13. If the motorhome is equipped with an icemaker, remove the  $\frac{3}{4}$  inch fitting and flush antifreeze through the water line.
14. Turn water pump off.
15. Open a hot and cold faucet to relieve line pressures then close the faucets.
16. Leave Prevent-A-Freeze switch(s) in "WINTERIZE" position until de-winterization.

**De-winterization:**

1. Drain the fresh tank.
2. Fill the fresh tank with water.
3. Turn the Prevent-A-Freeze switch(s) to "NORMAL" position.
4. Turn water pump on and operate all faucets, one at a time, until clear water is present.
5. Install new faucet water filter and fill water heater with water.
6. ICycle icemaker several times until fresh water is present and reconnect valve outlet line.
7. If applicable, operate washer/dryer to purge antifreeze from washer.

**WARNING: Use only designed non-toxic RV antifreeze for potable water systems. Automotive antifreeze, if ingested, can cause blindness, deafness or death.**

**CAUTION: Discard the first two trays of ice from the icemaker. They may contain contaminants.**

---

---

~ **NOTES** ~

---

---

---

---

---

---

---

---

---

---

---

---

---

---

---

---

---

---

---

---

---

---

---

---

---

---

# *LP-Gas System*

## *Section 7*

<b>LP-GAS SYSTEM.....</b>	<b>237</b>
<b>LP-GAS DETECTOR.....</b>	<b>238</b>
Testing .....	239
Alarm .....	239
Maintenance.....	240
<b>LP-GAS EMERGENCY PROCEDURES - CHECKLIST.....</b>	<b>241</b>
<b>LP-GAS TANK.....</b>	<b>241</b>
Measurement .....	241
Tank Filling .....	242
Tank Operation .....	243
<b>LP-GAS FUNDAMENTALS .....</b>	<b>244</b>
<b>LP-GAS REGULATOR .....</b>	<b>246</b>
<b>LP-GAS HOSE INSPECTION .....</b>	<b>249</b>
<b>LP-GAS DISTRIBUTION LINES .....</b>	<b>250</b>
<b>LP-GAS CONSUMPTION.....</b>	<b>251</b>
<b>LP-GAS SAFETY TIPS .....</b>	<b>252</b>



---

**LP-GAS SYSTEM**

The LP-Gas System section contains information and knowledge for the operation and care of the various Liquefied Petroleum (LP-Gas) system equipment found in the motorhome. The motorhome is equipped with several appliances and various equipment which are capable to operate on LP-Gas. Some items discussed may not be applicable to all motorhomes. More detailed information with **CAUTION** or **WARNING** instructions for the various equipment, other than what is found in this section, can be found in the manufacturer's manual in the owner's information box.

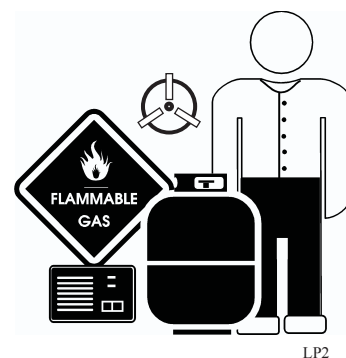

The LP-Gas tank mounted in the motorhome contains liquid petroleum gas that is under high pressure. As the fuel is used, liquid gas vaporizes and passes through the tank valve to a regulator that automatically reduces pressure. Low-pressure gas is then distributed to components through a pipe manifold system.

Component lighting problems are commonly caused by an improperly adjusted gas regulator. Do not attempt to reset the regulator. Adjustments need to be made by a dealer or an authorized service person.

In higher elevations or extreme cold weather (10° F/-21° C or lower) a shortage of LP-Gas may be experienced. Usage can be modified by running only one component at a time. For example, turn off the furnace while using the range. If LP-Gas is going to be used in higher elevations or cold climates for a long period of time, have an authorized service person adjust the LP-Gas regulator for these conditions.

Have the LP-Gas system checked by an authorized dealer at least once a year, and thereafter before every extended trip. Although the manufacturer and the dealer test the system carefully for leakage, travel vibrations can loosen fittings.

Leaks can be easily found by applying a leak detector solution on all connections. Leaks can usually be repaired by tightening the fittings. If not, shut off the main gas valve at the tank. Immediately see an authorized dealer for repairs. Hand tighten the tank valves only. Do not use a wrench or pliers as over tightening may damage valve seats and cause leaks. If a leak is suspected (which can be easily identified by the odor of rotten eggs or sulfur) never light a match, have an open flame or use any spark producing equipment or appliance.

**WARNING: LP-Gas is highly volatile and extremely explosive. DO NOT use matches or a flame to test for leaks. Use only approved LP-Gas leak testing solution for leak detection. Unapproved solutions can damage copper tubing and brass fittings. A liquid dish solution of 10 parts water may be used. Shake the solution until bubbles form and then apply the mixture to fittings and accessory control valves. All fittings tested should be thoroughly rinsed and dried after testing. Never attempt to adjust LP-Gas regulators. Only qualified personnel should perform any maintenance or repair to the LP-Gas system.**

## LP-GAS DETECTOR

The LP-Gas detector is required safety equipment in RVs. **American National Standards Institute (ANSI) A119.2 - Fire & Life Safety 3-4.8 LP Gas Detectors** states "A LP-Gas detector must be installed in any RV that contains an LP-Gas appliance and an electrical system. The LP-Gas detector must be listed as suitable for use in recreational vehicles under the requirement of UL 1484 Residential Gas Detectors, and installed according to the terms of its listing."

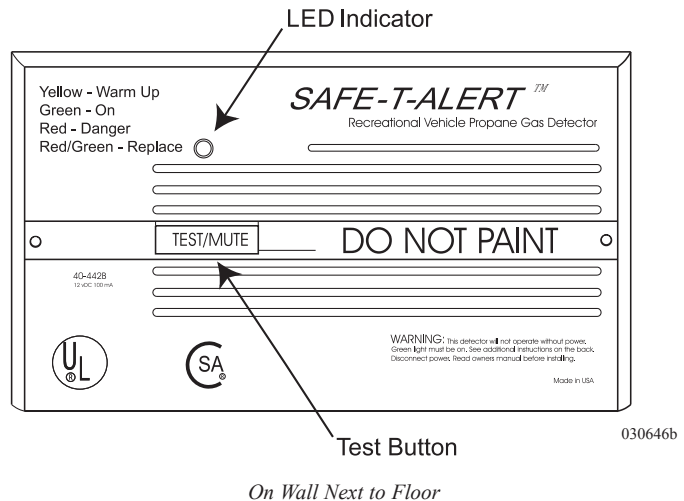

The detector senses both LP-Gas and methane gas. Liquefied Petroleum (LP) Gas is heavier than air; methane gas is lighter than air. LP-Gas will settle to the lowest point, generally the floor of the motorhome. Methane gas will rise. The gas detector is also sensitive to other fumes such as hair spray, of which most contain butane as the propellant. Butane, like propane, is heavier than air and will settle to the floor level. Sulfated batteries (rotten egg odor) will also sound the alarm. When this occurs, reset the detector to stop the alert sound.

**About the LP-Gas Detector:** It is important to be aware of the difference between a gas leak versus gas escaping from an unlit, open burner. Pure propane vapors from a leaking pipe or gas fitting are heavier than air and will build up heaviest concentration at the leak and float down to mix with air. Gas from open burners is intentionally mixed with air to induce burning and dissipate into the air. When mixed with air, gas becomes only marginally heavier and will expand outward. If a gas burner is left on, the area around the burner, range, and adjoining counter space will be combustible and can cause injury and damage if ignited. This condition will exist for an extended time period. Eventually, the gas will reach the detector's location and cause the alarm to sound.

**NOTE: The LP-Gas detector only indicates the presence of propane gas at its sensor. Combustible levels of LP-Gas may be present in other areas. This detector is intended for the detection of LP-Gas ONLY.**

The LP-Gas detector is not tested to detect other types of gas. However, other volatile gases (nuisance gases), most of them flammable in various concentrations, may cause the detector to alarm. Some products that may cause the detector to alarm are alcohol, liquor, kerosene, gasoline, deodorants, colognes, propellants used in spray cans and cleaning solvents. In some cases vapors from glues and adhesives used in the manufacturing of the motorhome may also cause the detector to alarm for several months after the date of manufacture. If it is determined that the detector has false alarmed because of the above mentioned nuisance gases, reset the detector and air out the motorhome with fresh outside air.

Take precautions to be sure one of these nuisances has not masked an actual gas alarm condition. The detector draws less current than one instrument panel lamp. The detector will operate to detect gas until the battery is drained down to 7.0 Volts. The detector must be supplied with a voltage higher than 7.0 Volts, for it to operate properly. If the power source is disconnected, or if the power is otherwise interrupted, the detector will not operate.

The LP-Gas leak detector has a self-check circuit which runs at all times while the detector is powered. In the event that the circuitry fails, a failure alarm will sound and the operating indicator will cease to light.

**LP-Gas Detector Operation:** Upon first application of power the LED will flash yellow for three minutes while the detector is stabilizing. At the end of the start cycle the LED will turn Green, indicating full operation. If the detector senses unsafe levels of gas it will immediately sound an alarm. The gas detector operates on 12 Volt DC, with a current draw less than 1/10th of one amp.

**CAUTION: The detector will not alarm during the three minute warm up cycle.**

---

### ***Testing***

Press the **TEST** switch any time during the warm up cycle or while in normal operation. The LED should flash red and the alarm should sound. Release the switch. This is the only way the detector should be tested. The test feature checks full operation of the detector.

**WARNING: Test the operation of this detector after the motorhome has been in storage, before each trip and at least once per week during use.**

---

### ***Alarm***

The **red** LED will flash and the alarm will sound whenever dangerous levels of propane or methane gas are detected. The detector will continue to alarm until the gas clears or the **Test/Mute** switch is pressed.

**Procedures to Take During an Alarm:**

1. Turn off all gas appliances, (stove, heaters, furnace), extinguish all flames and smoking material. Evacuate, leave doors and windows open.
2. Turn off the primary valve on the LP tank.
3. Determine and repair the source of the leak. Contact a qualified professional for service, if necessary.

**CAUTION: Do Not re-enter until the problem is corrected.**

**Potential Sources of LP Gas Leaks When Operating the Motorhome:**

- Cooktop Burners
- Water Heater
- Oven
- Defective Regulator
- Furnace
- Defective LP-Gas Connection
- Refrigerator
- Portable Propane Powered Equipment

**Alarm Mute:** Press the **Test-Mute** button when the detector is in alarm.

1. The **red** LED will continue flash and the alarm will beep every 30 seconds until the gas level has dropped to a safe level.
2. The LED will flash **green** until the end of the **Mute** cycle.
3. If dangerous gas levels return before the end of the **Mute** cycle, the alarm will beep four times and return to phase 1.
4. After two minutes the detector will return to normal operation (solid **green**) or resound the alarm if dangerous levels of gas remain in the area.

**Fault Alarm:** Should the microprocessor sense a fault in the gas detector, a fault alarm will sound twice every 15 seconds. The LED will alternately flash **red to green** and the **MUTE** switch will not respond to any command. The gas detector must be repaired or replaced.

---

**Maintenance**

1. Vacuum the dust off the detector cover weekly (more frequently in dusty locations) using the soft brush attachment of the vacuum.
2. Do not spray cleaning agents or waxes directly onto the front panel. This action may damage the sensor, cause an alarm or cause a detector malfunction.



## LP-GAS EMERGENCY PROCEDURES - CHECKLIST

If you smell gas (a rotten egg or sulfur smell) at any time, perform the following steps immediately:

- Shut off gas appliances.
- Manually turn off the primary shut-off valve at the LP-Gas tank.
- Do not attempt to operate any electric switch as this can produce a spark and could ignite the gas.
- Open windows and doors.
- Evacuate the motorhome. Stay clear of the surrounding area.
- Keep all sources of ignition out of the area.
- Contact a qualified service technician to find the source and repair the gas leak.

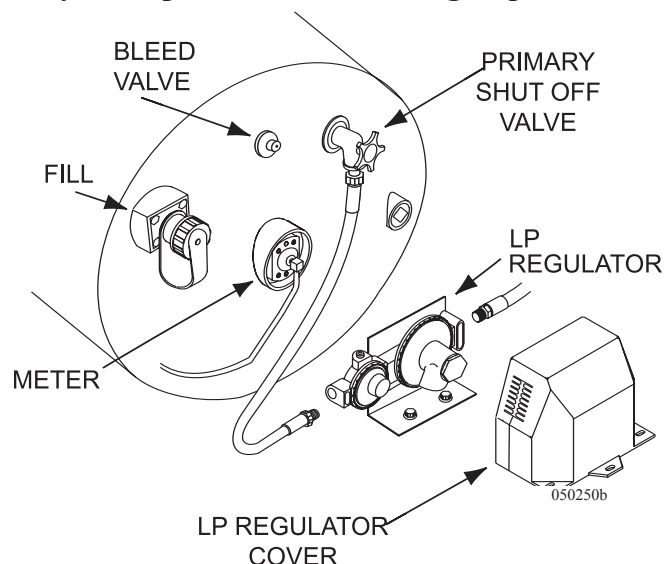

**WARNING: A fire or explosion from ignited gas or gas fumes can cause serious injury or death.**

## LP-GAS TANK - Measurement

Two methods can be used to monitor the amount of fuel in the LP-Gas tank. A small gauge is located on the LP-Gas tank. This non-adjustable gauge provides a quick view of the LP-Gas level. Push the TEST switch on the panel in the hallway and read the LPG level on the scale.

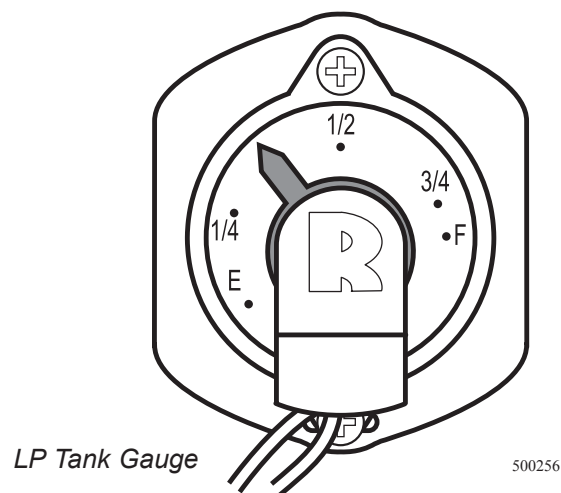
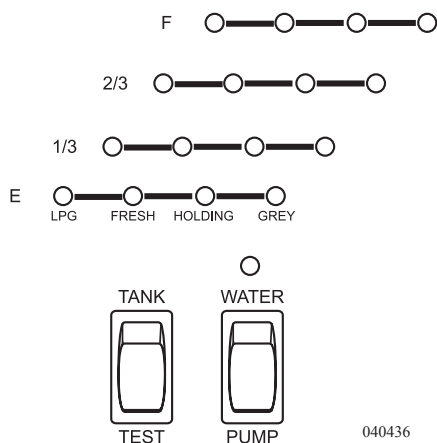

## Tank Filling

Woodall's Campground and Trailer Guide, and other similar publications, list refueling stations. Many travel parks sell LP-Gas. Before filling the LP-Gas tank, shut off the electric valve at the LP-Gas Tank fill port, pilot lights, appliances and igniters to prevent a fire or explosion. Have a trained service person fill the LP-Gas tank.

The LP-Gas tank fill is located in the curbside compartment. If the tank is new and being filled for the first time, inform the service technician to purge air from the tank before filling. When the tank is filled to the proper level, space is available for the conversion of liquid into gas. If a tank is over-filled, it may cause the safety valve to release pressure. When this happens, a strong rotten egg odor near the tank and/or a hissing noise may be detected.

A full LP-Gas tank is about 80% liquid and 20% vapor. The pressure inside the tank varies with the temperature of the liquid. All tanks are required to have a safety pressure relief device to release excess pressure. When the tank is full, the gauge on the tank will only read  $\frac{3}{4}$  full.

**NOTE:** Actual full liquid capacity is 80% of full tank capacity.

**CAUTION:** Pressure inside LP-Gas tanks can reach over 200 psi when exposed to direct sunlight. A high-pressure safety relief valve will purge excess high pressure, if necessary. LP-Gas will stop vaporizing as tank temperature approaches - 40° F. Appliances that consume large amounts of LP-Gas, such as the water heater or furnace, may need to be operated in sequence in extremely cold environments.

**WARNING:** Extinguish all sources of heat, sparks, flames and smoking materials within a 50' radius during the refueling process.

1. Turn off pilot lights, all appliances and the engine.  
Close all vents, doors and windows to prevent vapors from entering the motorhome.
2. Remove dust cover and screw nozzle to the fill valve.
3. Turn on dispensing pump, then open 80% bleed valve.
4. Open fill nozzle valve and dispense liquid into tank.
5. Close fill nozzle valve as liquid just begins to expel from 80% bleed valve. The overfill protection valve prevents filling the tank to more than 80%.
6. Close 80% valve and shut off dispensing pump.
7. Open high-pressure bleed valve on fill nozzle to remove pressure between dispensing pump and fill nozzle. Remove nozzle from the fill valve.
8. Install the dust cover.
9. LP-Gas appliances (especially the refrigerator) may have difficulty starting after a period of non-use. To speed the process of supplying fresh fuel to the appliances, light the stove first.

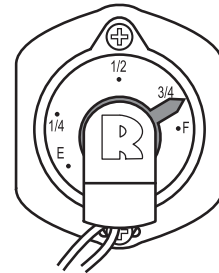

LP Tank Gauge

050256b

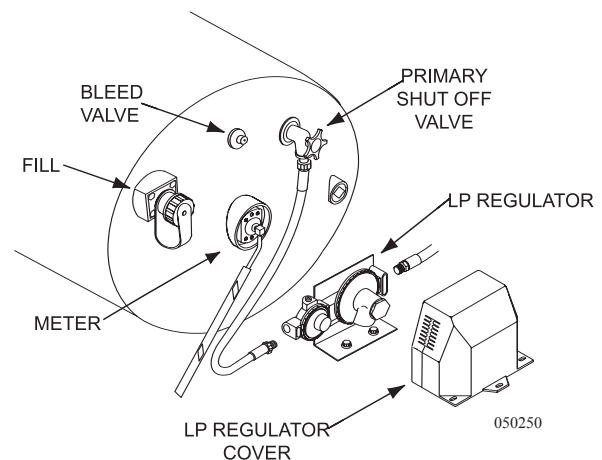

050250

**WARNING:** It is common for small amounts of liquid propane to escape and evaporate during the refueling process. Protect bare skin. Instant freezing will occur if exposed to liquid propane.

**WARNING:** When storing portable LP-Gas tanks that are not connected to an LP-Gas system, install an approved plug in the tank outlet holes to prevent leaks. Do not store or transport empty LP-Gas tanks, portable tanks, gasoline or other flammable liquids inside the motorhome. Keep open flame and spark producing materials away from the LP-Gas area. Shut off all appliances and the primary LP-Gas tank valve (located on the LP-Gas tank Roadside End) when the motorhome is in storage. If this warning is ignored, a fire or explosion could result.

**CAUTION:** Pressure inside LP-Gas tanks can reach over 200 psi when exposed to direct sunlight. A high-pressure safety relief valve will purge excess high pressure, if necessary. LP-Gas will stop vaporizing as the LP-Gas tank temperature approaches -44° F. Appliances that consume large amounts of LP-Gas, such as the water heater or furnace, may need to be operated in sequence in extremely cold environments.

## Tank Operation

### Tank Operation:

- Manually open the primary shut-off valve located on the LP-Gas tank.
- Turn off the primary valve on the LP-Gas tank when the motorhome is in between trips.
- Hand tighten the primary valve. Do not use a wrench or pliers to close the valve.
- The primary valve is designed to be closed by hand. Over-tightening the valve may permanently damage the valve seat.

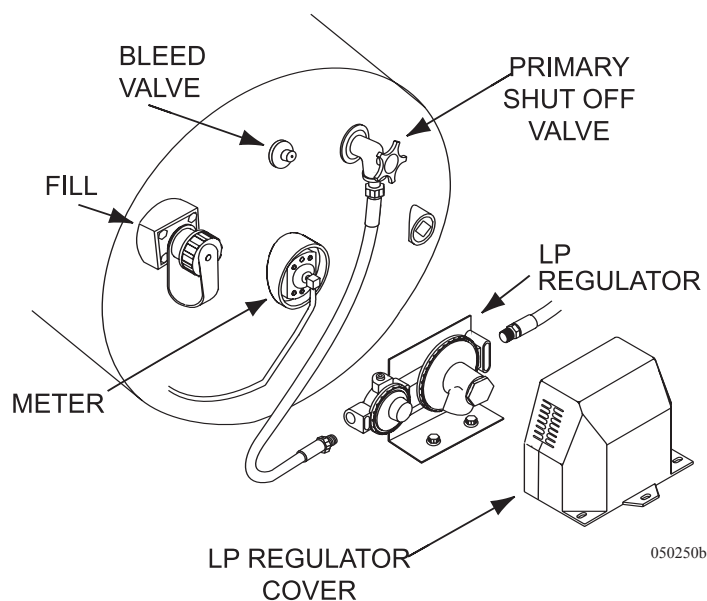

**Exterior Gas Line Hook-Up Prep:**

LP-Gas hook-up is for LP Accessories and is to be used on external components only. A LP-Gas quick disconnect fitting and flexible hose should be used to connect accessories to the line hook-up. Fitting should be installed by a qualified agency as defined in the national fuel gas code. (NFPA 54).

Every time accessory is used check for gas leaks on all connections, use a liquid dish detergent to 10 parts water. Agitate solution until bubbles form, then apply to all fittings and accessory control valve. If leak is detected, turn gas off at main LP tank and contact a qualified service center for parts.



**QUICK DISCONNECT FITTING**

**NOTE:**  
**COUPLING TO BE INSTALLED BY A QUALIFIED AGENCY AS DEFINED IN THE NATIONAL FUEL GAS CODE (NFPA 54)**

**INSTALLATION INSTRUCTIONS**

- 1) INSTALL SOCKET WITH SHUT-OFF VALVE ON THE GAS SUPPLY SIDE
- 2) INSTALL PLUG ON THE ACCESSORY SIDE
- 3) LEAK TEST USING SOAPY WATER SOLUTION

**OPERATING INSTRUCTIONS**

**TO CONNECT:**

- 1) CLOSE SHUT-OFF VALVE
- 2) PULL SOCKET SLEEVE BACK
- 3) INSERT PLUG; RELEASE SLEEVE
- 4) PUSH PLUG INTO SOCKET UNTIL SLEEVE SNAPS FORWARD
- 5) OPEN SHUT-OFF
- 6) LEAK TEST USING SOAPY WATER SOLUTION

**TO DISCONNECT:**

- 1) CLOSE SHUT-OFF VALVE
- 2) TO RELEASE PLUG, PULL SLEEVE BACK AWAY FROM PLUG; PULL OUT PLUG
- 3) INSERT PLUG; RELEASE SLEEVE
- 4) LEAK TEST USING SOAPY WATER SOLUTION

020155b

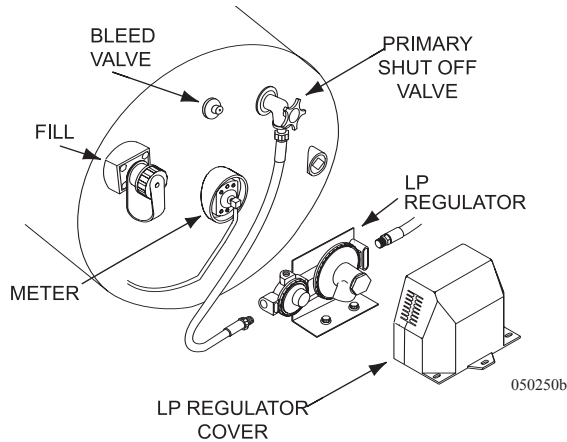

**LP-GAS FUNDAMENTALS**

# Capacity	Gallon Capacity	BTU Capacity
5	1.18	107,903
10	2.36	215,807
11	2.59	237,387
20	4.72	431,613
30	7.08	647,420
40	9.43	863,226

**CONVERSIONS**

Gallons to Liters (1 Gallon = 3.785 Liters)  
 Fahrenheit to Celsius ( $F^{\circ} - 32 \div 1.8 = C^{\circ}$ )  
 11 in. Water Column = 6 1/4 ozs. per sq. in. pressure.  
 27.7 in. Water Column = 1 lb. per sq. in. pressure.

**The above capacities allow for 20% vapor space on each cylinder.**

*Data taken from the National Fire Prevention Association (NFPA). Pamphlet #58-1998.*

**LP-Gas Statistics:**

Pounds Per Gallon	4.24
Specific Gravity of Gas	1.50
Specific Gravity of Liquid	.504
Cubic Feet Gas Per Gallon of Liquid	36.38
Cubic Feet Gas Per Pound	8.66
BTU Per Gallon	91,502
BTU Per Pound	21,548
Dew Point in Degrees Fahrenheit	- 44° F
Vapor Pressure at 0° F	31
Vapor Pressure at 70° F	127
Vapor Pressure at 100° F	196
Vapor Pressure at 110° F	230
Flash Point	842° F

**Basic Facts About LP-Gas:**

- LP-Gas detectors are a federal requirement on all LP-Gas equipped recreation vehicles.
- LP-Gas is a by-product produced by refining oil.
- Odor is added to LP-Gas after the refining process.
- Each liquid gallon of LP-Gas produces 91,502 BTU (British Thermal Units).
- Temperature affects pressure of LP-Gas.  
Internal tank pressure can exceed 200 psi.
- Tanks or valves contain pressure relief valves.  
The relief valve opens at 125% above tank rating.
- LP-Gas stops vaporizing at -44° F.
- Standard LP-Gas operating pressure is 11" of Water Column or approximately 6 ¼ ounces per square inch.
- An inch of Water Column is a measurement of applied pressure to one side of a U-Tube ½ filled with water at sea level. The amount of pressure required to raise the water level 11", represents 11" of Water Column.

**NOTE: The above information is not a complete guide for the use of LP-Gas tanks or appliances. In cold climates keep fuel levels above 50% in order to keep vaporization of LP-Gas at the highest level.**

## LP-GAS REGULATOR

LP-Gas is compressed into liquid form in the tank. Only the vapor is used during combustion by an appliance. As vapor is removed from the tank, the remaining liquid will vaporize to maintain pressure that is removed during consumption. This process will continue until there is no liquid remaining in the tank.

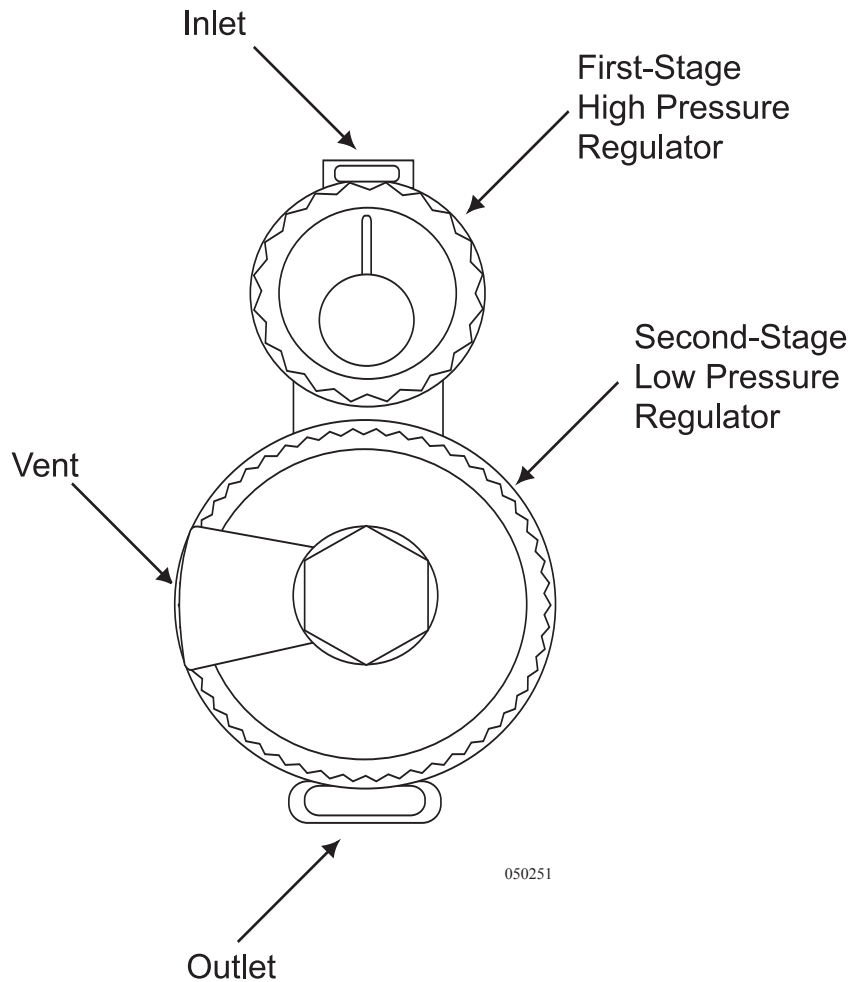

Temperature affects action of the liquid to vaporize. If temperature of the liquid is - 44° F. the liquid remains stable with tank pressure, about 0 psi. If liquid temperature is 100° F. the liquid quickly vaporizes with tank pressure, about 200 psi. Vapor pressure must remain relatively consistent regardless of temperature so that appliance heat output remains stable. Vapor pressure regulation is performed by the regulator.

The motorhome two-stage regulator reduces vapor pressure so that it is safe for use. The first stage of the regulator reduces tank pressure to a range of 10 to 13 psig (pounds per square inch gauge). The second stage further reduces pressure to a working pressure of 0.4 psig (11 Inches of Water Column or about 6¼ ounces psi.). A vent is installed to allow the internal diaphragm to move with atmospheric pressure change. It is important to keep the vent clean and clear of obstruction or corrosion. If the vent becomes clogged, pressure from LP tank may cause erratic pressure regulation. If there is any corrosion, contact a qualified LP-Gas service technician. The regulator is mounted so that the vent faces downward. If the vent becomes clogged, clean it with a toothbrush.

Under normal atmospheric conditions an LP-Gas regulator will not freeze, nor will the LP-Gas. Vapor passing through the regulator will expand and cool, condensing moisture in the gas. The moisture will freeze, build up and block the vent. The possibility of freeze up is greatly reduced with the two-stage regulator.

**To Prevent Freeze Up:**

- Ensure the LP-Gas tank is totally free of moisture prior to filling.
- Ensure the tank is not overfilled.
- Keep the valve closed when the tank is empty.

**If a Freeze Up Occurs:**

- Have an LP-Gas distributor purge the tank.
- Have the LP-Gas distributor inject methyl alcohol in the tank.

Damage to the regulator can occur when the tank is overfilled. The regulator is designed to work with vapor only. This is why the tank is filled to only 80% of its liquid capacity. The other 20% allows for vaporization of the liquid. The primary vapor valve is located in the vapor section of the tank. In an overfilled tank, liquefied petroleum can fill the regulator. As the liquid vaporizes, it can freeze the diaphragm. High tank pressure on a frozen diaphragm can cause a rupture resulting in erratic pressure regulation. This is why it is important to have the LP-Gas pressure checked for proper pressure and accurate regulation during appliance operation. Erratic pressure regulation dramatically effects refrigerator operation on LP-Gas.

**Manometers:** The manometer is the best way to accurately determine LP-Gas pressure. There are two different styles of manometers, a gauge and a U-tube. Gas pressure is measured in Inches of Water Column. This is the amount of pressure applied to one side of a U-shaped tube half filled with water. The amount of pressure needed to raise the column of water 11" represents **11 Inches of Water Column**.

**WARNING:** Do not attempt to adjust the regulator, it is preset at the factory. If adjustments need to be made it requires special equipment. Failure to follow these instructions may result in a fire or explosion and cause severe personal injury or death. Do not operate any LP-Gas appliance until the LP-Gas pressure is checked and a leak down test is performed!

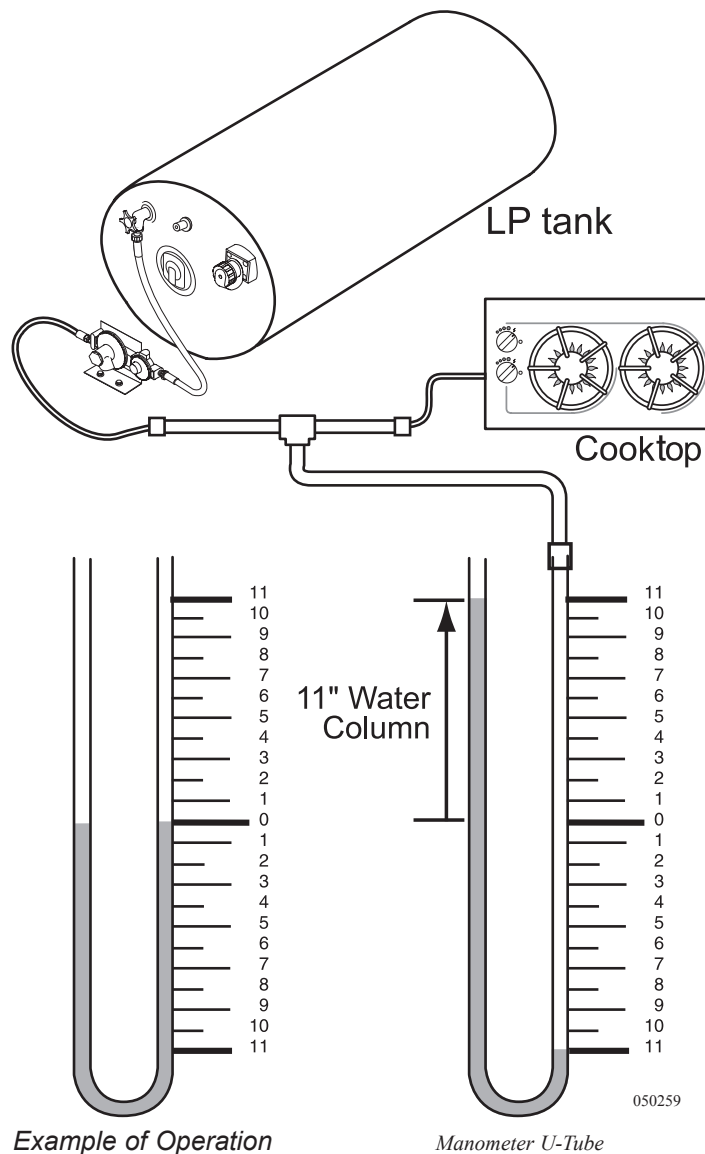
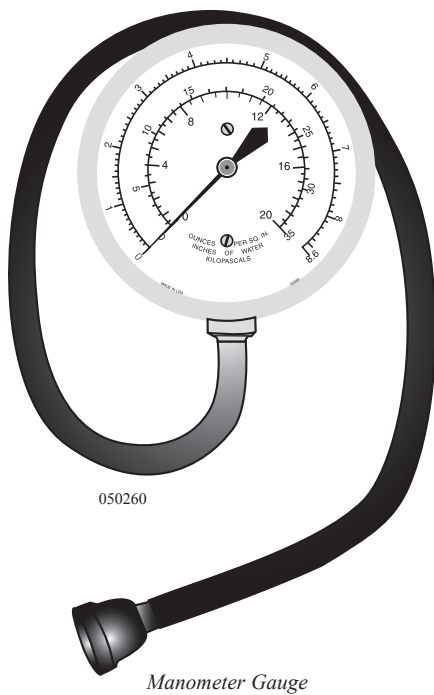



---

## LP-GAS HOSE INSPECTION

It is suggested by the hose manufacturer that the Liquid Propane Gas (LP-Gas) supply hoses, used on the motorhome, be subject to regular inspection. As a guideline, we suggest that all flexible LP lines connecting the slide-out, appliances, or tanks be inspected in the spring and fall of each year by a qualified RV technician.

According to the manufacturer, the inspections should consist of the following procedures and be performed when the hose is not under pressure:

1. **INSPECTION:** Inspect the outside cover of the hose for blistering, abrasion or cuts and coupling slippage. Cuts in the hose cover, which expose or damage the reinforcement, is cause for replacement. Hose strength is controlled by the plies of the reinforcement and damage in this area cannot be tolerated. Small cuts, nicks, or gouges in the cover that do not go completely through the cover will not be cause for replacement of the hose.

**NOTE: Pricking of the cover in the manufacture of this type of hose is common and necessary for satisfactory hose performance. Consequently, the uniformly pricked cover should not be viewed with alarm.**

2. Damage to the textile reinforcement or wire braid is cause for hose replacement. Wire braid reinforced hose, which has been kinked or flattened so as to permanently deform the wire braid in the unpressurized state, shall be removed from service.
3. Blistering or loose outer cover is cause for hose replacement.
4. Examine couplings for slippage. Slippage is evidenced by the misalignment of the hose and coupling and/or the scored or exposed area where slippage has occurred. Any evidence of slippage is cause for hose replacement.
5. It is important that if a damaged LP-Gas hose is found, the source of the damage be determined and corrected prior to the replacement of the LP-Gas hose.

**NOTE: Only a qualified RV technician should complete replacement of LP-Gas components.**

It is also suggested, that the flexible LP-Gas supply lines on your recreational vehicle be replaced every ten (10) years. The manufacturer of the LP-Gas supply lines recommended this schedule after performing extended testing and have determined that the failure rate may rise after this period of time. The motorhome manufacturer recommends following these guidelines to assure continued safety and dependable use.

## LP-GAS DISTRIBUTION LINES

A primary manifold black steel pipe running throughout the motorhome distributes LP-Gas to secondary lines. All secondary lines leading to gas appliances are made of copper tubing with flared fittings. If any lines rupture do not attempt to splice them. Always run a new line. We recommend gas distribution work be performed by an authorized dealer or an authorized service technician. When removing or servicing any gas appliance, manually close the main valve located on the side of the LP-Gas tank. This will prevent dangerous gas leakage that could result in an explosion and possible serious injury.

**INSPECTION:** Inspect the rubber flexible lines, twice a year, for abrasions, tears, kinks or other signs of damage.

If a gas leak is suspected, get the system inspected and repaired by a qualified service technician as soon as possible.

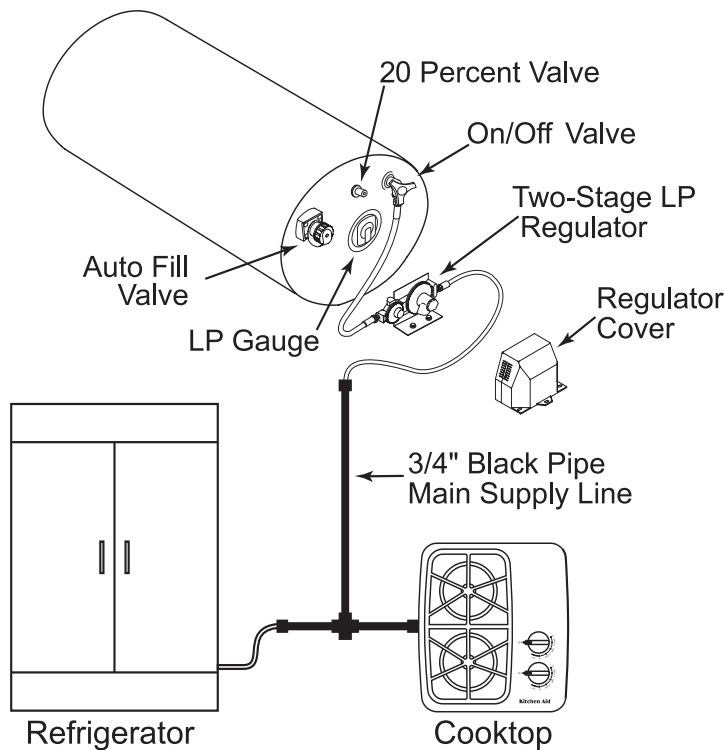

050257o

---

## LP-GAS CONSUMPTION

Each gallon of LP-Gas produces 91,502 BTUs of heat. One 27 gallon tank produces two million BTU's. Total consumption depends on the rate of usage by each appliance and the operating time. The stove typically uses the most gas.

### **Determine Fuel Consumption:**

To determine approximately how many hours an LP-Gas appliance will operate on one gallon of LP-Gas, use the following formula:

- LP-Gas appliances are rated in Input BTU (British Thermal Units). The rating is usually stamped or printed on a tag affixed to the appliance. For example: the Input rating of the appliance is 10,000 BTUs.
- One gallon of LP-Gas produces 91,502 BTUs.
- Divide the amount of BTUs of one gallon of LP-Gas (91,502) by the rating on the appliance in this example 10,000. Net continuous operation time for one gallon of LP-Gas for this appliance would be approximately 9.2 hours.

The above formula can be useful when trying to determine the approximate length of time a tank of LP-Gas will last. Generally, LP-Gas appliances do not operate continuously. An example would be the typical cycling of the refrigerator.

### **Determining how long a tank of LP-Gas will last:**

- Combine the BTU input totals of all appliances, and the approximate length of time these appliances operate per day.
- Multiply the number of liquid gallons in the LP-Gas tank by 91,502.
- Divide the total of BTUs of the LP-Gas tank by the total number of BTUs the appliances consume, equals the approximate number of hours of operation before refueling.

**WARNING: LP-Gas is highly volatile and extremely explosive. Never use matches or open flame to test for leaks. Use only approved LP-Gas leak testing solution to test for leaks. Unapproved solutions can damage copper tubing and brass fittings. Never attempt to adjust LP-Gas regulators without the use of proper equipment. Improper LP-Gas regulator adjustment will affect the performance of LP-Gas operated appliances. Incorrect flame or explosion can occur. Only qualified personnel should perform any maintenance or repair to the LP-Gas system.**

## LP-GAS SAFETY TIPS

Liquid Propane gas is one of the safest and most reliable fuels available on the market when handled properly. LP-Gas, however, does have a great explosive “potential” if handled improperly. Danger is minimized by becoming familiar with and following a few safety precautions, and by learning how to properly operate LP-Gas appliances. Use of LP-Gas requires the responsibility to enforce extra safety measures.

The motorhome is equipped with many LP-Gas operated appliances because it is a convenient and efficient source of fuel. LP-Gas appliances must be operated and maintained in accordance with the product manufacturer’s instructions.

The National Propane Gas Association (NPGA) has a special service program offered called GAS<sup>®</sup> (Gas Appliance System) Check. The GAS<sup>®</sup> Check program is aimed at educating users about the convenience of propane with safety and peace of mind. For information on the **NPGA Gas<sup>®</sup> Check program, call (202) 466-7200 or visit [www.npga.org](http://www.npga.org).**

**LP-Gas Tanks and Cylinders:** Tanks are built to American Society of Mechanical Engineers (AMSE) Code. The cylinders are built to DOT (Department of Transportation) Code. The major difference between cylinders and tanks is in required testing and inspection procedures, and in construction of the containers. Both tanks and cylinders are required to undergo pressure testing and inspection; however, the procedures for how they are tested and inspected differ.

The difference between the two codes are that the valves, fittings and brackets are located only on the ends of the DOT cylinders; however, on the ASME tanks they may be located on ends, as well as the sides. There is also a difference in how the tanks are rated. Required tank ratings are in gallons (ASME ratings) or pounds (DOT) water capacity. The Federal DOT (Department of Transportation) regulations require periodic inspections and re-qualifications of cylinders.

American Society of Mechanical Engineers (AMSE) tanks or bulk containers are generally used in motorhomes, and are permanently mounted on to the unit.

An alloy steel two-piece welded and brazed tank is used on all towable products. The marking on the collar, DOT 4BA240, identifies the DOT specifications and service pressure. Other pertinent information included on the collar is the water capacity (WC) and the tare weight (TW), both which are measured in pounds, and the manufacture date (one of the most important items). There is a required 12 year re-qualification. The final piece of information is Dip Tube (DT) length. This is part of the overfill protection and maximum liquid allowance in the cylinder.

**Maintenance and Safety Tips for the LP-Gas Refrigerator:**

- Have the refrigerator, furnace and venting **inspected** annually by an authorized service center.
- Before firing up the refrigerator, or using the propane gas furnace for the first time each season, have the venting system checked for blockage. Insects may have built nests that will obstruct flow.
- At the first indication of incomplete combustion (yellow flame instead of a blue flame or soot is present) contact a service technician immediately. Improper combustion can cause carbon monoxide buildup, which is potentially fatal!

**Maintenance and Safety Tips for the Propane Range:**

- Burner flame should be a blue color, indicating complete combustion. If not, have the unit serviced by a qualified technician.
- Do not cover the oven bottom with foil. Air circulation will be restricted.
- Never use gas ranges or ovens for heating purposes.
- Always have pot handles turned inward.
- Ensure children understand never to turn or play with the knobs on the front of the propane gas range.

**Maintenance and Safety Tips for the Propane Water Heater:**

- Keep flammable substances away from the water heater. Do not store items close as this may block the airflow the water heater needs to operate properly.
- At the first indication of incomplete combustion (yellow flame instead of a blue flame or soot is present) call a service technician immediately. Improper combustion can cause carbon monoxide buildup, which is potentially fatal!



# *Electrical Systems - House*

## *Section 8*

<b>ELECTRICAL HOUSE - INTRODUCTION</b> .....	<b>257</b>
Converter (60 Amp) .....	257
Shore Power.....	258
Generator .....	258
Inverter/Converter (Opt).....	258
<b>BATTERY DISCONNECT - HOUSE</b> .....	<b>259</b>
<b>BATTERY CUT-OFF SWITCH</b> .....	<b>259</b>
<b>SHORE POWER HOOK-UP</b> .....	<b>260</b>
Manual Cord Reel (Opt) .....	263
<b>TRANSFER SWITCH</b> .....	<b>263</b>
<b>GENERATOR - 120 AC DIESEL</b> .....	<b>264</b>
Pre-Start Checks .....	264
Starting the Generator .....	265
Stopping the Generator .....	265
Powering the Equipment .....	266
Generator Fuel .....	266
Resetting the Circuit Breaker .....	267
Generator Exercise .....	267
<b>INVERTER/CONVERTER (OPT)</b> .....	<b>268</b>
Remote Control .....	270
Troubleshooting.....	273
<b>DISTRIBUTION PANEL (50 AMP)</b> .....	<b>274</b>
Energy Management System (Opt) .....	275
Fuses .....	277
GFCI Breakers & Outlets .....	278
Tools of the Trade .....	279
Know When to Say No .....	279
<b>BATTERY</b> .....	<b>280</b>
How It Works .....	280
Battery Types .....	280
Testing the Battery .....	281
Battery Maintenance.....	282
Battery Voltage & Current .....	283
Battery Charge Time & Consumption Rate .....	284
Electrical Layout .....	285





## ELECTRICAL HOUSE - INTRODUCTION

The motorhome 120/240 Volt AC system can be operated from three different power sources: shore power, the on-board generator or the inverter/charger. Shore power is the most efficient and should be used whenever possible. The on board generator can be used when shore power is unavailable. The inverter/charger supplies silent AC power using the house batteries of the motorhome. This source has limited AC power output and should be used sparingly.

Two different sources supply the main AC circuit breaker panel with power: the 50 Amp shore power cord or the on board generator. The power source used is selected automatically by an automatic electrical switching device known as a transfer switch.

**WARNING: The electrical system is engineered and tested for complete safety. Circuit breakers and fuses protect the electrical circuits from overloading. If you plan modifications or additions to the electrical system, we strongly recommend consulting your dealer for assistance to ensure continued integrity and safety of the electrical system. Please note that any modifications may void the warranty.**

### Converter (60 Amp)

The power converter is designed to provide a filtered 12 Volt DC power to the lighting and appliance circuits. It will also recharge and maintain the unit's battery. The power converter is virtually maintenance free. There are some tests which can be performed to ensure the power converter is functioning properly.

- The output on terminals should read 13.6 Volts DC +/- .3 Volts.
- **Inspect** the fuses to ensure they are not blown.
- The power requirement for the converter is 120 Volts AC.

If the converter output is correct, but the battery is not charging, there may be a problem with an open wire between the converter and battery.

If the fuses are blown the battery was connected in reverse. It only takes one second of reverse connection to blow the fuse.

If the power requirement for the converter is met, the fuses are good, and there is no output from the converter, the converter is bad and will need to be replaced.

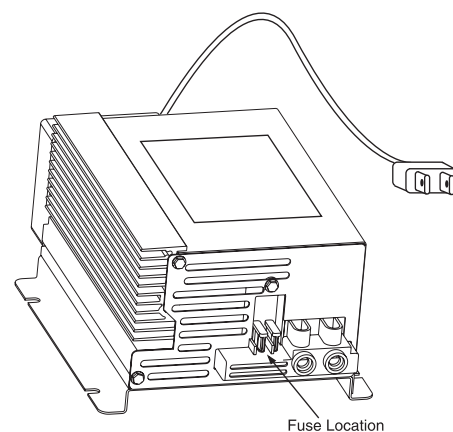

Typical View of Converter

060087

## **Shore Power**

The motorhome is equipped with a shore power cord. The electrical cord connects the motorhome to outside electrical services. Shore power service is the most efficient source of electrical power. Use this as the primary power source. The plug end of the shore power cord is 50 Amp 220 Volt. Many facilities are equipped with this power service. When this type of power service is not available electrical adapters will be required to allow a proper and safe connection to the electrical service supply.

**NOTE: In instances when 50 Amp shore service is not available, care will have to be used when operating the appliances and using the outlets so the shore power service will not be overloaded.**

---

## **Generator**

The generator can be selected for use when AC shore power is not available. The generator maximum amount of output power, measured in watts, is calculated at an elevation of 500 feet above sea level. This figure will decrease slightly with a higher altitude. Ambient temperature also effects total maximum output. The amount of AC electrical load applied to the generator determines fuel consumption.

---

## **Inverter/Converter (Optional)**

The inverter/converter can be used for silent AC power if shore power is not available, and using the generator is not going to be selected as a secondary power source. This device has limited AC power output, measured in watts. It operates only selected appliances and outlets. The inverter/converter is two components in one. First is as an auxiliary 120 Volt AC power source that uses 12 Volt DC house battery power to invert to 120 Volts AC. The second function of the inverter/ converter is to use 120 Volts AC power, supplied from either shore power or the generator, and convert it to 12 Volts DC power to recharge the batteries. When dry camping, the inverter may be used to supply power to selected outlets.

## BATTERY DISCONNECT - HOUSE

The main battery disconnects are located in the rear curbside battery compartment. In the compartment are a pair of battery disconnects: One for the chassis batteries and the other for the house batteries. Turn off the batteries any time the motorhome is going to be stored and not in use. If possible, leave the motorhome plugged into an AC source with the battery disconnects on. This will help prevent the batteries from going dead. Use of the battery cut-off switch at the entry door will not turn off all DC electrical items. There are small “parasitic” loads that are present on both the house and chassis batteries. Some are federal mandate items, such as the LP detector. If the motorhome will not be used, or will be stored for more than 48 hours, it is recommended to turn the batteries off.

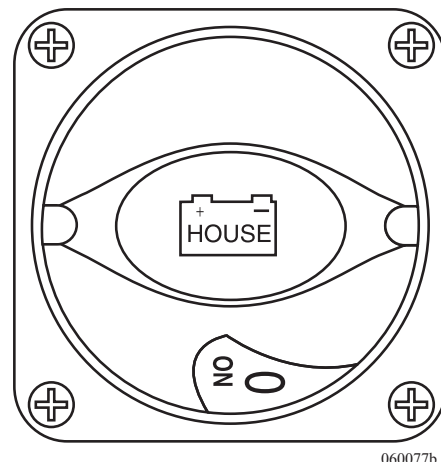

## BATTERY CUT-OFF SWITCH

The battery cut-off switch is located inside next to the entry door. This switch controls the 12 Volt DC power to the interior 12 Volt panel and select front distribution panel circuits. The switch locks into the center position preventing interior DC power from being accidentally turned on or off. When the switch is activated, power is supplied to all interior DC lighting and DC operated appliances. Some appliances will require both DC and AC power to operate, such as the roof air conditioner. This switch is helpful when dry camping and can be used to conserve house battery power. Refrigerator and inverter operation are unaffected by the operation of this switch. When the interior house power is off, there are still parasitic loads on the house batteries and therefore is not a substitute for the main battery disconnect switch.

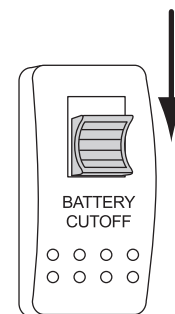

Release  
Lock

080375

**CAUTION: To avoid flash damage to electrical contacts, turn off the interior lighting before activating the battery cut-off switch.**

## SHORE POWER HOOK-UP

The power requirement for the motorhome is 50 Amp 120/240 Volt AC single phase. The shore cord is stored in the roadside compartment. If 50 Amp shore power service is available, all that is necessary is connect the supplied shore power cord. If 50 Amp service is not available, electrical adapters will be required.

**CAUTION:** Avoid flash damage to the electrical system contacts. Before hooking up to shore power, starting the generator or using the inverter make sure all the appliances are off.

**WARNING:** Keep fingers away from metal contacts of the shore plug end. Avoid standing in water when making electrical connections. Serious electrical shock and personal injury can occur. To avoid the risk of an electrical shock, turn the circuit breaker off for the power supply outlet before making the shore power connection.

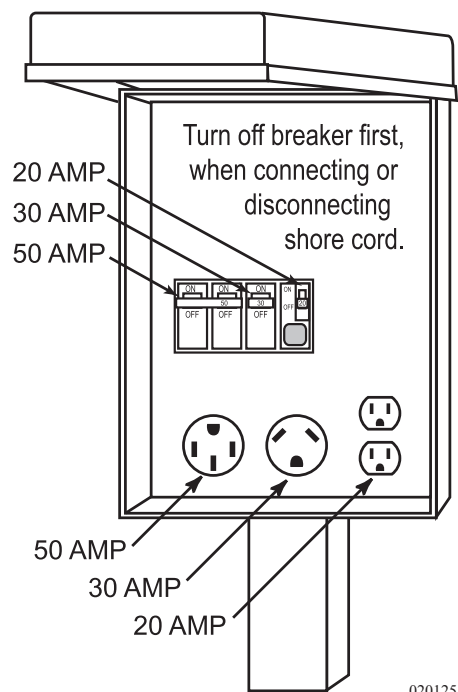

020125

**Power Supply:** Different amperage supplies vary greatly in the amount of available current.

- The continuous amount of current through a breaker or fuse is only 80% of its rated capacity.
- 50 Amp 240 Volt AC shore power service consists of two power supply conductors (120 volt AC each), a neutral and a safety ground. The 50 Amp breaker simultaneously limits each power supply conductor to no more than a short-term maximum of 50 Amps for each conductor. The 50 Amp 240 Volt service actually provides 80 continuous amps.
- Use care when hooked to anything less than 50 Amp shore service. Shore power service less than 50 Amps consists of one power supply conductor, a neutral and a safety ground. 30 Amp shore service is limited to 24 continuous amps. 20 Amp shore service is limited to 16 continuous amps.

**Plugging in the Shore Cord Power Supply:**

- Located in the roadside compartment is the shore power cord.
- Manually extend a sufficient amount of cable to reach the power supply. If 50 Amp service is not available, install the proper electrical adapter(s) to the cord.
- Always turn off the shore power breaker to the power supply before connecting or disconnecting the shore cord. This will prevent an accidental shock and flashing of electrical contacts.
- After the connection is made, turn the shore power breaker on. The transfer switch should make an audible click.
- Go inside the motorhome to verify AC power is available. The AC In light on the inverter remote panel should be lit and the microwave display should be lit.

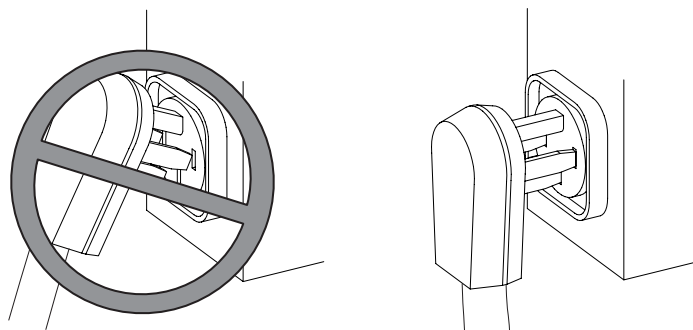

Incorrect Method

Correct Method

060212

After connecting the motorhome to shore power, wait approximately one minute for the inverter/charger or converter to "stabilize" charging of the batteries before starting air conditioners or other large AC loads. In the instance 50 Amp service is not available, use caution not to overload the supplied shore service breaker. Operate appliances and outlets in sequence rather than all at the same time.

**Disconnecting the Shore Cord:**

- Turn off all AC appliances. This will prevent accidental shock and flashing of electrical contacts when disconnecting.
- Turn off the shore power breaker.
- Grasp housing of electrical cord. Without touching electrical contacts, work cord out and away from socket.

**Electrical Adapters:** There are many different electrical adapters available to suit a variety of needs. Only UL approved adapters should be used. The most common adapter is a 50-30 Amp adapter. The type of connector adapts the 50 Amp shore cord to a 30 Amp shore power outlet. Always install the adapter to the cord prior to making the connection to the outlet.

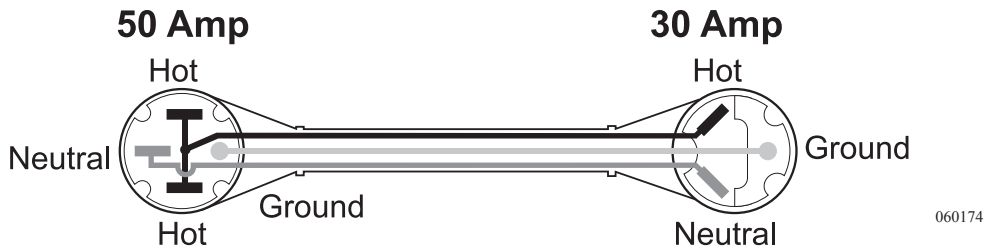

Another common adapter is a 30 to 20 Amp adapter. This type of connector adapts the 30 Amp shore cord to a 20 Amp shore power outlet.

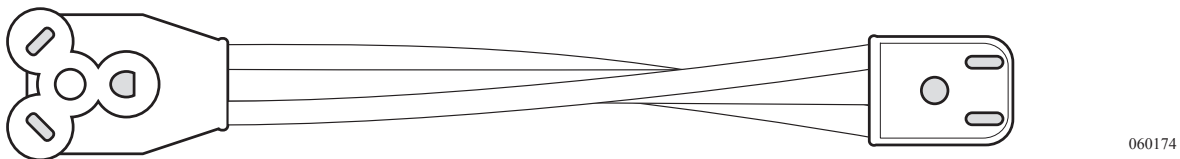

**CAUTION:** If shore power service is limited to 15 or 20 Amps, use of light duty extension cords and electrical adapters will create a voltage loss through the cord and at each electrical connection. Line voltage loss and the resistance at each electrical connection can be a hazardous combination. Damage to sensitive electronic equipment may result!

**CAUTION:** Avoid the risk of electrical shock or component damage by disconnecting from shore power during electrical storm activity. Use the inverter or start the generator if AC power is needed.

**NOTE:** Three types of shore power outlets most commonly used are shown in the illustration below.

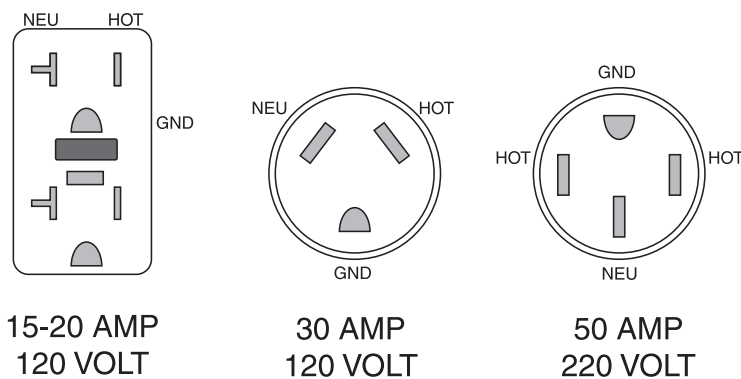

060121

**Manual Cord Reel (Optional)**

The cord reel will coil and stow the shore cord. The cord reel is located in a roadside compartment of the motorhome. The other end of the power cord is wired directly to the transfer switch. Use the hand crank to retract the power cord. To extend power cord, pull out. Extend only as much power cord as required to reach the outlet. The cord should not be taut, but slightly slack.

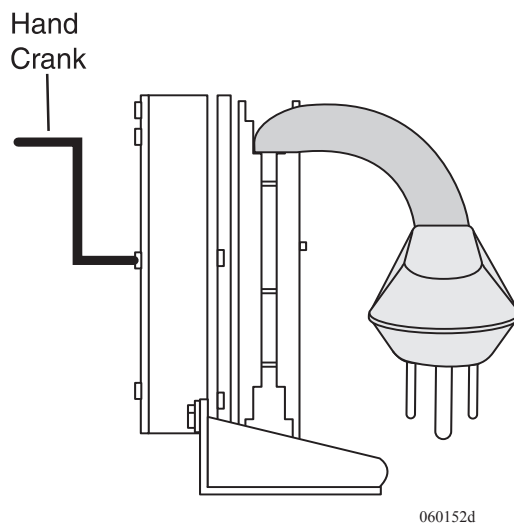
**TRANSFER SWITCH**

The transfer switch automatically transfers AC power from the shore power cord or generator through the transfer switch to the 110/220 Volt AC breaker panel. When using the generator as the power source, the transfer switch has a time delay built into it before transferring power to the AC breaker panel. This allows the generator time to warm up before applying an AC load. When operating the generator while hooked to shore power, the transfer switch automatically selects generator power as priority over shore power.

**NOTE: The shore cord is NOT electrically connected to the generator. When the generator is operating, the electrical contacts of the shore cord are not electrically energized.**

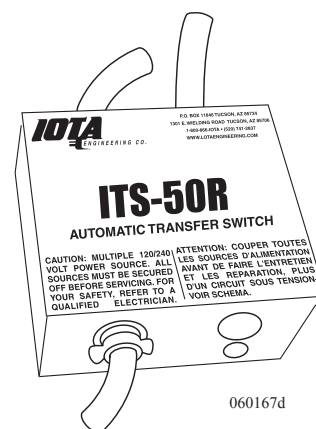

## GENERATOR - 120 AC DIESEL

The generator is located in the front compartment of the motorhome. To open the generator compartment, pull and release the manual locking mechanism handle located within the license plate access. To close the generator compartment, push the door closed until the slide mechanism latches. The generator can be started from the following locations:

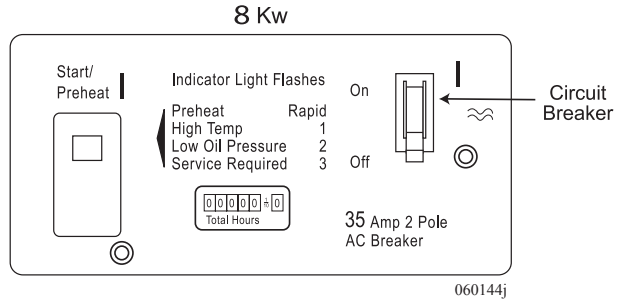

- The generator remote switch on the dash.
- The generator control panel located on the generator.
- The inverter control Auto Gen start feature.

### Pre-Start Checks

Prior to the first start of the day perform a general inspection including oil and coolant levels. Keep a maintenance log on number of hours in operation since the last service. Perform any service or maintenance that may be due.

#### Before Starting the Generator:

- People and animals must be clear of hazards of electrical shock and moving parts.
- All appliances and other large AC electrical loads must be off.

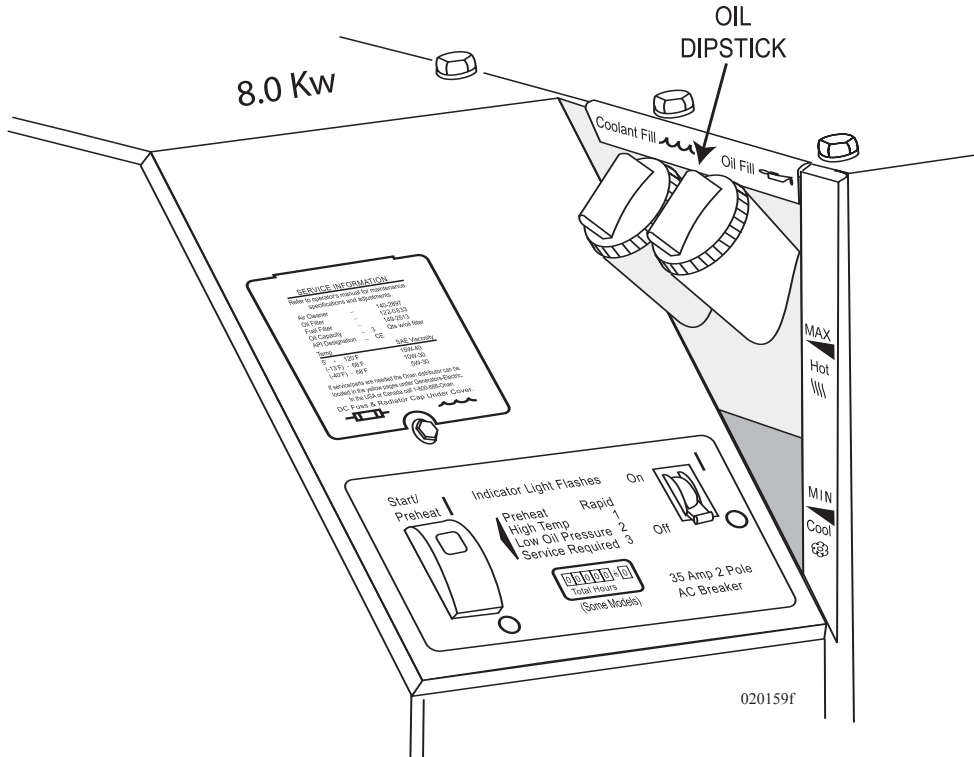



## Starting the Generator

Push and hold control switch in START position until the generator starts. Release switch. On diesel models the control switch may flash up to 15 seconds, indicating engine preheat.

**NOTE:** Diesel models may require priming. Hold control switch in the OFF position for one minute. Repeat if necessary. The diesel generator fuel pick-up tube is cut to approximately 1/4 tank so as not to run the main engine out of fuel.

**WARNING:** Excessive cranking can overheat and damage the starter motor. Do not crank the engine more than 30 seconds at any one time. Wait at least two minutes before resuming.

**NOTE:** If the generator fails to start refer to the generator manufacturer's owner's manual.

**WARNING:** When the motorhome is parked, position the dash air conditioner vent control in the OFF position to prevent exhaust gases from entering the motorhome. The engine exhaust contains carbon monoxide, which is an odorless and colorless gas. Carbon monoxide is poisonous and can cause unconsciousness and/or death. Inspect the exhaust system thoroughly before starting the generator. Do not block the exhaust pipe or situate the motorhome where the exhaust may accumulate either outside, underneath, or inside the motorhome or any nearby vehicles. Operate the generator only when safe dispersion of exhaust can be assured. Monitor the outside conditions to be sure that the exhaust continues to disperse safely.

**WARNING:** When parking near high grass, be sure that the hot exhaust does not come into contact with the grass, it could be a fire hazard. Hot exhaust pipe or hot exhaust gases can ignite the grass.

**CAUTION:** An exhaust extension adds weight and stresses the generator exhaust system. Damage to the exhaust piping or exhaust manifold can result, allowing Carbon Monoxide gases to accumulate under or leak into the motorhome.

Press Top to  
START

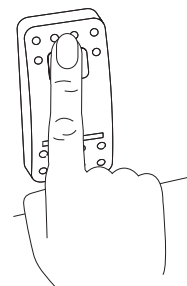

Press Bottom to  
STOP

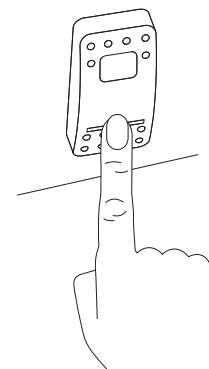

080357

## Stopping the Generator

Turn off the appliances and disconnect other AC loads being used. Allow the generator to run unloaded for at least one minute before shutdown. This will allow the engine to cool. Momentarily push the control switch in the STOP position until the generator stops. Release the switch.

## **Powering the Equipment**

The AC output of the generator powers the motorhome air conditioners, the AC inverter/converter charger, all appliances and items plugged into the electrical outlets of the motorhome. The number of electrical appliances that can be operated at any given time depends upon how much power is available from the generator. If the generator is "overloaded" or a short circuit causes "over current," the generator will shut down or the circuit breaker will trip. If power consumption, in total, exceeds the generator power output, compensation for temperature and elevation may be necessary. Operate some appliances in sequence rather than all at the same time.

**NOTE:** The generator may shut down when it is loaded nearly to full power and an air conditioner (or other large motor load) cycles on. For a brief moment during start up an electric motor can draw up to three times the rated power. For this reason, it may be necessary to operate some appliances in sequence when air conditioners or other large motor loads are on.

It is important to remember that air density decreases as altitude increases, causing the generator engine power to decrease. Power decreases at approximately 3% of the rated power each 1,000 feet (305M) of increase in elevation above sea level. It may be necessary to operate fewer appliances at the same time when the camping location is at a higher elevation. For example: 7500 watt generator at 5,000 ft. = 6375 watts net. Temperature also affects maximum output power. For example: At 120° F. a 7500 watt generator produces 6000 watts net.

**INFORMATION:** The generator may shut down for reasons beside "overloads." A blink code may appear on the control switch. Refer to the manufacturer's manual to obtain an explanation of the codes.

---

## **Generator Fuel**

When refueling there is always a possibility the fuel may be contaminated. Contamination of fuel affects the performance of the generator. Diesel fuel may contain water or a microbe growth (black slime). Propane, due to the refining process, may contain lightweight oil. Any contamination of fuel greatly reduces the total output of the generator and may cause erratic AC output.

<b>Average Fuel Consumption</b>	<b>Diesel 8,000 Watts (gal./hr.)</b>
No Load	0.13
Half Load	0.49
Full Load	1.02

**NOTE:** The motorhome manufacturer does not cover damage to the generator caused by fuel contamination, or to appliances due to erratic AC voltage.

## Resetting the Circuit Breaker

If a circuit breaker trips in the main AC breaker panel, or on the generator control panel, there may be a short circuit or too many loads.

**NOTE: The generator will continue to run after a circuit breaker trips.**

If a circuit breaker trips, disconnect or turn off as many loads as possible. To reset the circuit breaker, switch the circuit breaker to **OFF**; then switch back to **ON** to reconnect the circuit. If the circuit breaker immediately trips, the electrical distribution system has a short or the circuit breaker is faulty. Call a qualified electrician. If the circuit breaker does not trip, reconnect a combination of loads that will not overload the generator or cause the circuit breaker to trip again. Remember to compensate for elevation and temperature changes when reconnecting loads.

**NOTE: An appliance or load may have a short if it causes a circuit breaker to trip after reconnection. DO NOT continue to reset breaker. Have the problem corrected before resuming operation.**

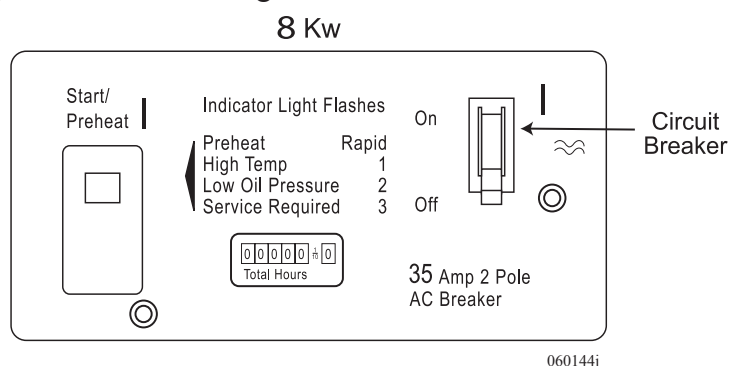

## Generator Exercise

If use of the generator is infrequent, “exercise” the generator once a month by operating it at approximately half the maximum rated output for two hours. This “exercise” will help promote better starting, more reliable operation and longer engine life. This procedure drives off moisture, relubricates the internal engine parts and replaces the old stale fuel with a fresh supply. It also promotes removing oxides from the electrical switches and contacts.

**NOTE: Avoid short run periods of the generator set. Run the generator set under a load for a minimum of one-half hour.**

## INVERTER/CONVERTER (OPTIONAL)

The inverter takes Direct Current (DC) from the batteries and turns it into Alternating Current (AC). The inverter also takes Alternating Current when the motorhome is connected to shore power and transforms that into Direct Current to recharge the batteries. There are two modes of operation associated with the inverter/charger:

- **Inverter Mode:** Direct Current (DC) from the motorhome batteries is transformed into Alternating Current (AC) for use with electrical appliances.
- **Charger Mode:** Alternating Current (AC) is taken directly from shore power (or other AC sources) and passed directly to household appliances. At the same time, incoming AC is also converted to DC to recharge the motorhome batteries.

**Search:** With search mode enabled, the inverter pulses the AC output looking for an electrical appliance (typically 5 to 100 watts, depending upon the setting you've selected). When there is no load detected, the inverter automatically goes into search mode (sleep) to minimize energy consumption. During sleep time, the inverter's green LED flashes (fast) to indicate SEARCH mode. When an appliance is switched on inside the motorhome, the inverter recognizes the need for power and automatically engages.

**Inverter Mode:** When AC Shore Power is no longer sensed, the inverter automatically transfers to battery power with no interruption to appliances. The inverter's green LED flashes once every two seconds (medium flash) to indicate it is running on battery power and providing AC to the motorhome.

**AC Shore Power Mode:** Whenever AC Shore Power is sensed, the inverter automatically transfers to the shore power with minimal interruption to appliances.

**Bulk Charge Mode:** When the inverter is running on nominal AC Shore Power, it will charge the batteries. The inverter's green LED stays ON (solid) to indicate the first stage of charging. During Bulk Charge, the maximum amount of constant current is supplied to the batteries. As battery voltage rises to a set value (typically 14.1 VDC for GEL, 14.3 VDC for AGM and 14.6 VDC for liquid lead acid), the charger will then switch to the next charging mode.

**Absorption Charge Mode:** As the inverter continues to run on nominal AC Shore Power and the batteries have been successfully bulk charged, the charger enters a second stage of charging. The inverter's green LED flashes once every second (fast flash) to indicate absorption charging for one to three hours depending upon battery bank selection (refer to the Remote Control Manual). The charger then switches to final charging mode.

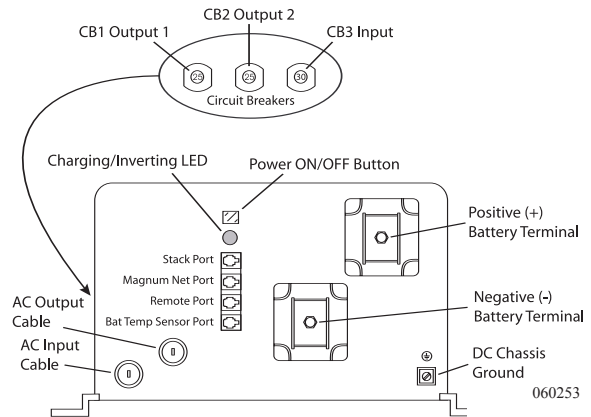

**Float Charge Mode:** As AC shore power continues, the inverter's green LED flashes once every eight seconds (slow flash) to indicate the third and final stage of charging. The batteries are held at the float voltage (typically 13.6 VDC for GEL, 13.1 VDC for AGM and 13.4 VDC for liquid lead acid) as long as AC is present at the inverter's input. Float charging reduces battery gassing, minimizes watering requirements (for flooded batteries) and ensures the batteries are maintained at optimum capacity.

**Battery Saver™ Mode:** Designed to keep batteries fully charged over long periods (storage) without drying them out. Whenever the charger is in float for four hours with no DC loads running, the charger will turn OFF. If the battery voltage drops below 12.5 VDC, the charger will automatically initiate float mode to return them to a full charge.

**Fault or Alarm Conditions:** The inverter monitors the AC Shore Power, the batteries and itself. Whenever a condition occurs that is outside the normal operating parameters, the inverter will take the necessary steps to protect your appliances, batteries and itself from damage.

**Low Battery:** When battery voltage reaches a low level, the inverter will initiate Low Battery Cutoff (LBCO) which automatically shuts the inverter down, along with all connected loads, and protects the batteries from over-discharge damage. The inverter's LED turns OFF to indicate the fault condition.

**High Battery:** As the inverter is charging, it constantly monitors the batteries. In the event battery voltage approaches excess charge, the inverter automatically turns off the battery charger to protect the batteries from damage. The inverter's LED turns OFF to indicate the fault condition.

**NOTE: High battery voltage may be caused by excessive voltage from the alternator, solar panels or other external charging sources.**

**Overload:** During inverter and AC Shore Power operation, the inverter monitors the AC and DC circuits. In the event of a short-circuit or overload condition, the inverter will shut down. The inverter's LED turns OFF to indicate the fault condition.

**Overtemperature:** During inverter operation, if the inverter becomes overheated, it will shut down to protect itself from damage. The inverter's LED turn OFF to indicate the fault condition.

## Remote Control

The remote allows you to customize the operation of the inverter/charger. The remote features Soft Keys, a Rotary Knob, LEDs and a two-line LCD readout. The automatic power saver mode turns off all LEDs as well as the LCD display five minutes after the last Soft Key has been pressed. The display will “wake up” with any keystroke or whenever a change in operational status occurs.

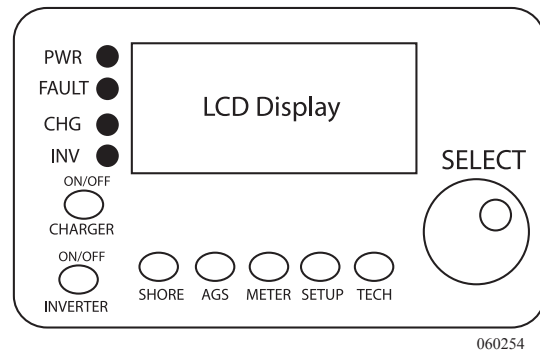

**Front Panel:** The remote control is equipped with switches and displays that allows quick set-up of the inverter/charger and determination of operational status.

**Rotary Knob:** The rotary “spin” knob is similar to a dash radio knob and used to move between menus to select program options. Turn the rotary knob clockwise to increase selections and counterclockwise to decrease selections. Push the knob to save the selection displayed in the LCD screen.

**Inverter ON/OFF Button:** Used to switch the inverter function ON and OFF. The green “INV” LED turns ON and OFF with the switch.

**Charger ON/OFF Button:** Used to to switch the charger function ON and OFF. The green “CHG” LED turns ON and OFF with the switch. Press and hold the switch down for five seconds to initiate equal voltage charge to each battery.

**Soft Key Buttons:** Press the buttons to access the required function. Then use rotary “SELECTOR” knob to scroll through the selections. Press the rotary knob to save the selection.

- 1. Shore** - Sets the appropriate breaker size for the incoming shore power and is used to control the amount of AC amps the battery charger uses. Selection options are 5, 10 , 15, 20, 30 and 50 amps.
- 2. AGS** - Turns the optional Auto Gen Start function ON and OFF. Selection options are OFF, ENABLE AND TEST.
- 3. Meters** - This function is displayed only and indicates DC volts, DC amps, AC volts and AC amps.
- 4. Setup** - Configures the inverter/charger.
  - **Search:** Used to set the search watts at which the inverter will come out of “sleep” mode. Selections are 3 - 75 watts.
  - **LBCO (Low Battery Cut Out):** Used to set the DC voltage level to shut down the inverter and protect the batteries from over-discharge damage. Selections are 9.0 VDC, 10.0 VDC and 11.0 VDC. DC volts must reach and maintain low battery cut out setting for one minute before inverter shut down is initiated.

- **Battery Size:** Used to select the approximate battery bank capacity. Selections are in 200 amp increments from 200 - 1000 amps. Battery capacity is also used to determine absorption time during battery charging.
  - **Battery Charge Rate:** Used to set the maximum charge rate during bulk, absorption or float charge. Selections are in 10 amp increments from 10% - 100%.
  - **Battery Type:** Used to select battery type for the battery charge profile. Selections are Gel, AGM (Absorbed Glass Mat), Liquid Lead Acid (Flooded) and Custom (future).
  - **Contrast:** Used to adjust the LCD contrast.
  - **AC Dropout Voltage:** Used to select the AC voltage threshold (60, 90, 100 VAC) where the inverter transfers from AC line to inverter mode.
5. **Tech** - This feature is used for troubleshooting the inverter/charger. Options include FET temperature, transfer temperature, battery temperature and resetting all settings to factory defaults. Press and hold button for five seconds, "Reset Complete" will appear in the display.

**LEDs:** The remote contains the following LEDs to indicate various modes of operation.

**1. PWR (green):**

- **OFF** - No AC power from inverter, shore or generator at inverter output terminals.
- **ON** - AC power available from inverter, shore or generator at inverter output terminals.

**2. FAULT (red):**

- **OFF** - Normal operation.
- **ON** - Inverter or Charger shutdown from Overtemperature (check tech menu for exact cause), Low Battery Voltage (battery voltage below LBCO setting or lower than 9.0 VDC, High Battery Voltage (above 15.5 VDC) and AC Overload (loads larger than inverter output capacity).

**3. CHG (green):**

- **OFF** - Charger OFF, no shore or generator AC present.
- **Fast Blink** - AC present from shore or generator, synchronizing to AC waveform before relay transfer.
- **ON** - Bulk, Absorb, Float, Equalize or Battery Full Charge mode.
- **Slow Blink** - Charger Standby (Charger off button was pressed with AC available from shore or generator), Charger Backoff (charger temperature too hot and charger automatically reduced charge rate to maintain temperature) and Low AC Input Voltage (Input voltage below 85 VAC. Charger automatically disabled to help stabilize AC line voltage).

**4. INV (green):**

- **OFF** - Inverter OFF.
- **Slow Blink** - Search Mode. AC load below the Search Watts setting.
- **ON** - Inverter ON and supplying AC to output terminals.



**NOTE:** When the INV and CHG LEDs are “ON”, the inverter is in standby mode. Shore or generator AC power is passed through the inverter to the loads. If shore or generator power is lost, the inverter automatically supplies AC power to the loads.

**LCD Display:**

**1. Inverting:**

- **OFF** - Unit is “OFF” with no shore or generator AC power applied.
- **Search** - Unit is in search mode. AC loads are less than the search watts setting.
- **Inverting** - Unit is inverting power from the batteries into 120 VAC at its output.

**2. Charging:**

- **Bulk Charge** - The battery charger is delivering maximum current to the batteries. The charger will remain in bulk charge until the bulk charge voltage is achieved.

**NOTE:** Reduce maximum current by adjusting the battery charge rate and shore power settings using the setup options.

- **Absorption** - Absorption charge is the second stage of charging and indicates the bulk voltage has been reached. The DC current will start to taper off in order to maintain bulk voltage setting. Absorption time is determined by battery bank size selection.
- **Float** - At the end of absorption time, the charger reduces the charge voltage to the float voltage setting for the battery type selected.
- **Battery Saver™ (“Battery Full”)** - Maintains batteries without “overcharging”, preventing excessive loss of water in flooded batteries or drying out of AGM batteries. After 4 hours in float mode, the charger is switched OFF and “Battery Full” is indicated. When battery voltage drops to 12.9 VDC, the charger turns on and float charges batteries to a nominal level. Once that level has been reached, the charger returns to “Battery Full” mode to monitor the batteries.
- **Equalize** - The battery charger delivers equalize voltage to the batteries for a maximum of 4 hours. Press and hold the switch down for 5 seconds to initiate EQ. The LED will blink quickly.

**NOTE:** Equalize mode will not start until the charger is in float or “Full Battery” mode.

- **Low Battery** - The unit has shut down because battery voltage is below the set point in low battery cutout. It will automatically restart when voltage rises above 12.5 VDC.
- **High Battery** - The unit has shut down because the battery voltage has exceeded 15.5 VDC and will automatically restart when the battery voltage drops below 15.5 VDC.
- **Overtemp** - The unit shut down because the temperature at the transformer or FET board exceeded the safe temperature operating range and will automatically restart after unit cools down.
- **AC Overload** - The unit shut down because the AC load connected to the inverter output exceeded maximum output rating.

**NOTE:** When this occurs, reduce the load and manually restart the unit.



**Troubleshooting**

<b>SYMPTOM</b>	<b>POSSIBLE CAUSE</b>	<b>RECOMMENDED SOLUTION</b>
No output power. Inverter LED is OFF.	Inverter is switched OFF. Battery voltage is too low.	Switch the inverter ON. Check battery voltage, fuses, breakers and cable connections.
No output power. Inverter LED is OFF.	High or low battery voltage.	Check the battery voltage at the inverter's terminals. Discharge or charge batteries. Replace the batteries.
No output power. Green LED is flashing.	Load is too small for search mode circuit detection.	Reduce the search threshold or defeat search mode.
Low output power.	Low batteries.	Check and recharge batteries.
Appliances turn OFF/ON. Green LED is flashing.	Loose or corroded battery cables. Low batteries. Loose AC output connections.	Clean and tighten all cables. Recharge or replace batteries. Tighten AC output connections.
AC output voltage seems too low when using a meter.	Wrong type of voltmeter used (displays 80 VAC to 100 VAC).	Use a "true" RMS voltmeter.
Low surge power.	Low batteries. Battery cables are the wrong length or gauge.	Check and recharge batteries. Verify recommended cable lengths and gauges from the manual. Replace cables as necessary.
Low charging rate when connected to shore power.	Charge rate set too low. Low AC voltage (<90 VAC).	Adjust charge rate from remote. Check AC input wiring.
Low charging rate when using a generator.	Generator output is too low to power both load and charger.	Reduce the load. Increase the generator's RPMs.
Charger doesn't charge.	Loose or corroded battery cables. Defective batteries. Wrong charger settings. Wrong AC input voltage.	Clean and tighten all cables. Replace the batteries. Adjust the charger settings. Verify proper AC input voltage and frequency.

## DISTRIBUTION PANEL (50 AMP)

The AC distribution panel is located in the bedroom. The main AC panel 120 Volt circuit breakers receive power from the transfer switch, which is powered by either shore power or the on board generator. Power is introduced into the panel to the 50 Amp MAIN breaker first, followed by power being fed into the individual branch circuit breakers. The panel label describes the breaker layout and the item, outlet or appliance to which they pertain.

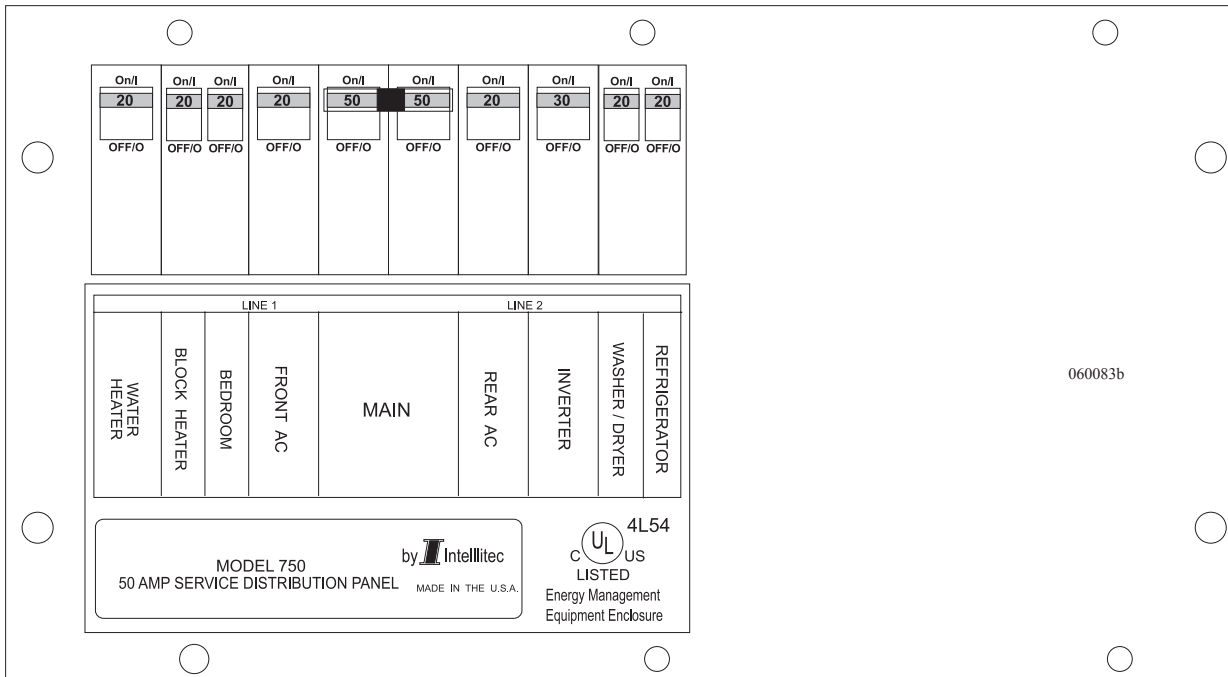

**NOTE:** This panel will change with options.

**WARNING:** The 240/120 Volt AC panels contain high voltage which can cause serious injury or death. Before beginning any work or testing procedures involving the electric panels, or any of the branch circuits, be sure the motorhome is unplugged from shore power, the generator is not running and the inverter is in the off position. Certain testing procedures may require the AC power to be on. Only qualified personnel with electrical backgrounds should attempt any testing procedures.

Branch circuit breakers supply AC power to the different items or “loads.” An electrical load is any item or device that will use current when supplied with an electromotive force. Should a breaker “trip” from over current use, or a short circuit condition, the load to which the breaker is supplying the electromotive force should be reviewed or disconnected to determine the cause of the trip. If no cause is found, or not readily apparent, reset the breaker by toggling the breaker to the OFF position, then back to ON. Should the breaker trip again after the load is reapplied it may indicate a fault with that particular load. Do not continue to reset breaker until the problem has been diagnosed and corrected.

Breaker current ratings are current set points in which the breaker is designed to operate. The internal configuration of the circuit breaker is designed to trip when excess continuous current is drawn through the breaker. The trip action of the circuit breaker can occur within milliseconds due to the speed at which electricity can travel. Breaker ratings are set to operate on a continuous load at 80% of the breaker's rated capacity and handle loads in excess of their rating for short periods of time. This designed set point is when an inductive load is applied, such as when an electric motor turns on. As the motor starts to spin, current consumption may momentarily exceed the rated capacity of the breaker. As the electric motor comes up to operating speed the electric motor's current consumption will fall. The AC current load then falls back into the breaker's rated 80% set point. This electric principle should be kept in mind when using anything other than 50 amp shore service and using appliances with electric motors. When using outlets care should be considered when applying loads such as electric motors, heaters, coffee makers, toasters, hair dryer or other large current consuming loads. If the current rating of a load is not known it is usually stated on most electrical items. The rating will either be in amps or watts.

Current ratings stated on electrical items will change slightly with voltage fluctuations. As voltage increases current consumption decreases. As voltage decreases current consumption increases. This may explain why in some instances items operated at borderline voltage to current tolerances may seem fine in one location but problematic in another.

**NOTE:** To calculate watts to amps simply divide the watt figure by the voltage of which the item operates from. For example: The electrical item is rated at 1370 watts. Divide that by the operating voltage of 115 volts which equals 11.913 amps. Use this formula to calculate load to current supply ratio.

---

### ***Energy Management System (Optional)***

The Energy Management System is easily identified by the remote display panel located inside motorhome.

The 50 Amp Smart EMS consists of two elements: the display panel and the bedroom distribution panel. The distribution panel, located in the bedroom, is a completely self-contained 120/240 Volt power distribution and energy management system intended to be used in recreational vehicles. It is housed in a sheet metal enclosure with removable front panel. It provides circuit protection for all the 120 Volt AC loads in the motorhome and a system of energy management to minimize the over-loading and tripping of circuit breakers.

**Circuit Breakers:** The distribution panel offers slots for eight single or dual, standard 120 Volt circuit breakers. Two of these breakers, located in the two center positions, must be a 50 Amp unit that act as a main input protection for each of the lines supplying the remainder of the branch breakers (up to 12).

**Energy Management:** The 50 Amp Smart EMS automatically senses the available power to the motorhome, determining whether it is connected to a 120 Volt AC - 30 Amp shore power source, 50 Amp shore power source or generator source. Depending upon available power, the EMS controls the operation of 6 possible loads as indicated on the distribution panel. These may be any type load, but are typically heavier loads; those whose use can be "postponed until a time when current is available for use. If the available power source is 120 Volt AC - 30 Amp shore power, the EMS attempts to keep the total 120 Volt current draw to less than 30 Amps.

**Operation:** If 120 Volt AC is not available at the distribution panel, L1 or L2 outputs, the system shuts itself off. This feature is intended to prevent the system from drawing current from the +12 Volt DC battery supply when not in operation.

When 120 Volt AC power is applied, the system automatically powers up and determines the nature of the power source.

If the generator is running, 120 Volt AC will be present at the distribution panel L1 and L2 inputs. In this mode the energy management feature is disabled and all control relay contacts are closed, energizing all of the controlled loads. The control module sends a signal to the display panel causing the load meter to display actual load current, the GEN SET service indicator to light and all power status indicators to light.

If 120 Volt AC is present at the distribution panel L1 and L2 inputs the system will assume that 120 Volt AC, 30 Amp shore power is available and the energy management feature will be enabled. **If only 20 Amp service is available the user must select the 20 AMP service mode by momentarily pressing the 20/30 Amp select switch on the Control Panel.** Initially, all relay contacts are closed and the total current is monitored. If the total current should exceed the service limit the system will turn off the first load in the shedding table, turning the loads off and calculating the amount of current that was removed, which is the value for that load. This value is placed in memory. If the current remains above the service limit, the system will turn off the next load in shedding table, again calculating the amount of current that was removed and placing this value, which is the value of that load, in memory. The system continues to turn off loads until the total current falls below the service limit or all of the six controlled loads have been shed. Through this process the system has “learned” the amount of current that each particular load draws. This feature compensates for the differences in current draw over a range of line voltage and ambient temperature, by re-learning the load each time it is turned off or “shed.”

The 50 Amp Smart EMS now waits until the total current is lower than the service limit and enough current is available (as compared with the amount in memory for the last load shed) before turning that load back on. This assures that there is sufficient current to operate the load.

**NOTE: There is a two minute minimum delay period after a load is shed before the load will be turned on again to prevent air conditioners from turning on with a head pressure.**

**Three Hour Averaging:** The RVIA (Recreational Vehicle Industry Association) in conjunction with the NEC (National Electrical Council) have established rules regarding the rating of electrical systems and the use of energy management systems. One of these rules requires that, if any energy management system is used, the average total load current for the system over a 3 hour period be limited to 80% of the service rating. For that reason the 50 Amp EMS calculates the average running current for the system and, if it exceeds 80% of the service rating, the EMS sheds loads to reduce the average current below that limit.

For example, if a system operating under 120 Volt AC, 30 Amp service has been running at the 30 Amp limit for three hours, the EMS will change its shedding threshold to 24 Amps and turn off loads until the 24 Amp limit is attained. If the user selects the 20 Amp service mode this limit will translate to 16 Amps. Because the EMS calculates a running 3 hour average, if the average load current drops below the limit the system will restore power to loads based on their impact on the limit. If the system is in the averaging mode the decimal point at the lower right corner of the load meter display on the display panel will illuminate.

**Display Panel:** The display panel connects to the distribution panel located in the bedroom. Six power status LED's indicate power is applied to those loads. These LED's are on when the power is applied. The load meter has a two digit display to indicate the amount of current actually being drawn by all the appliances in the motorhome.

Four service type LED's indicate the source for 120/240 Volt AC power. Three of these sources are automatically detected and indicated by the EMS, namely: Gen Set Service, 50 Amp Service and 30 Amp Service.

**The 20 Amp service mode is not automatically detected and the operator must manually select the 20 Amp mode when 20 Amp service is available.** The service select button allows the current threshold to be set to either 30 Amps or 20 Amps, to match the incoming service.

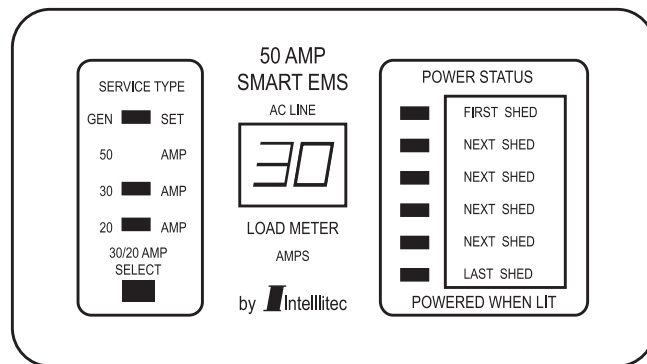

060082

## Fuses

The 12 Volt DC fuses protect the low voltage electrical circuits. These fuses are a standard automotive type. When a fuse is "blown," the wire in middle of the plastic case will be burnt. A broken, bad or "blown" fuse must be replaced with a fuse of the same rating and type. Using a fuse with a different rating or type will defeat the circuit protection provided by that fuse and could result in damage to the motorhome electrical system.

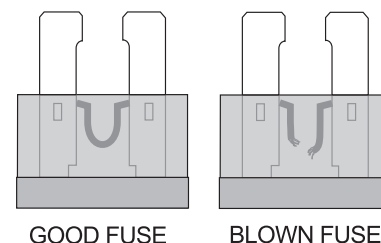

060086

The 12 Volt fuses, located in this distribution panel, service the interior house lighting, ventilation fans, monitor panel, furnace and water heater. Should a fuse blow it will be evident by the broken metal strip located in the center of the fuse. Replacement fuses should be of the same amperage. If a higher rated fuse is installed it can damage the wiring. Blade style fuses are color coded to reflect their amperage rating. See chart for details. Fuse current set points follow much of the same electrical principle as the 120 Volt AC breakers. Using 12 Volt DC as the electromotive force can make it more susceptible to outside influences, such as corrosion from weathering or oxidation.

The large variety of applications this voltage can be used in makes it a diet staple for most of the recreational vehicle and automotive industries. The danger from shocks with this voltage is minimized, but can still occur. A good example is when a magnetic field is generated, then collapses when the power supply is cut. The result is a discharge that can reach tens of thousands of volts for a short time period. Care should be used when working with this voltage as current values can be quite high, like in the case of a battery cables.

Shorting a battery cable to ground with a battery at a reasonable state of charge can result in a fire or serious personal injury from a burn.

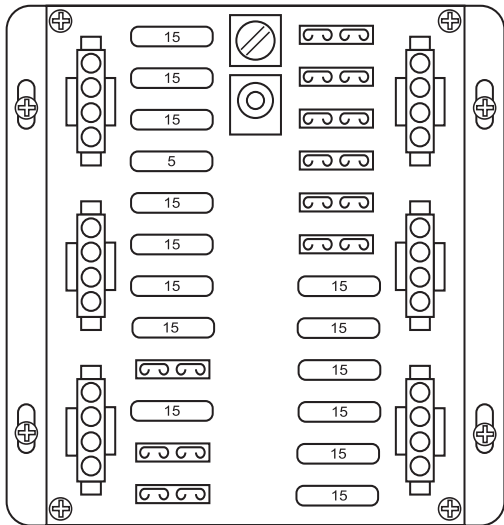

060165

FUSE	CIRCUIT	AMP	COLOR	GA.
F1	BATH ROOM—PASS SIDE	15	BLU	14
F2	PORCH, PASS SIDE NON SLIDE	15	YEL	14
F3	BEDROOM	15	GRN	14
F4	FRONT VENTS	15	VIO	14
F5	CEILING LTS, FRONT	15	RED	14
F6	REAR VENTS	15	VIO/BLK	14
F7	ACCENTS/COURTESY LIGHT (OPT)	15	BRN	14
F8	REAR RADIO (OPT)	15	GRY/BLK	14
F9	BATH DRIVER SIDE	15	ORG	14
F10	GALLEY LIGHTS	15	RED/BLK	14
F11	REAR BATH (DST- DBD)	15	BLU/BLK	14
F12	REAR OVERHEAD (PLQ)	15	GRN/BLK	14
F13	FURNACE / ROOF A/C	15	GRY	14
F14	MONITOR PANEL / WATER PUMP	10	RED	12
F15	WINTERIZATION (OPT)	15	GRN	14
F16	DASH RADIO SWITCH (OPT)	5	GRY	16
F17	AUTO GEN START (OPT)	15	ORG	14
F18	OPEN			
F19	REAR DRIVER S/O (OPT)	15	GRN	14
F20	REAR PASS S/O PDQ	15	BLK	14
F21	EXT. RADIO (OPT.)	15	VIO/BLK	14
F22	110V WTR HTR, SYSTEM PANEL	15	BLK	14
F23	KITCHEN FURNACE (OPT.)	15	GRY/BLK	14
F24	OPEN			

#03213170 C

060286

### GFCI Breakers & Outlets

A ground fault circuit interrupter “GFCI” can be found in two different types of applications. One type is incorporated in a breaker used in 120 Volt AC breaker panels, the other is incorporated in an outlet. The GFCI, whether it is a breaker or an outlet, offer two types of protection. One type of protection is from over-current or shorts. It also provides protection for persons against hazardous ground fault currents which can result in injury or death. Ground fault currents are currents that flow from the “HOT” or power terminal through a person to the ground. For example, touching a faulty appliance while standing on or making contact with an electrical ground such as a water fixture, bath tub or the earth. If the device has been properly installed it will offer protection against the type of shock that can result from faulty insulation, wet wiring from inside an appliance, or any device or equipment plugged in or wired to that circuit. The “ground fault” portion of the outlet or breaker uses sensitive electronics inside the outlet or breaker to detect a ground fault problem. The electronics monitor the normal current of power, flowing to the “hot” or black wire through the load (eg. a light bulb or appliance) and coming back on the “neutral” or white wire. If just a small amount of the current comes back on the safety ground wire the electronics will “trip” the breaker or outlet, stopping the flow of electricity. The amount of current it takes to trip the device from a ground fault varies slightly from the different outlet or breaker manufacturers (about 30 mils or less). Electrical shocks resulting from ground faults can be felt, but such a shock is considerably less than one without ground fault protection. People with heart conditions, or other conditions that make them susceptible to shock, can still be seriously injured.

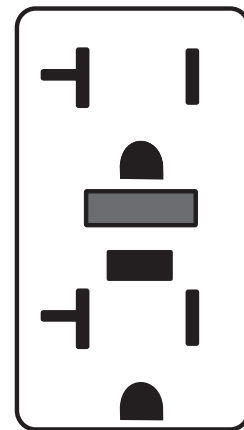

GFCI Outlet

060072



A GFCI outlet or breaker will not protect against shock from a normal current flow. For example, a shock from touching both metal prongs of an electrical cord or appliance while plugging it in.

**WARNING: If a breaker or outlet trips continually DO NOT continue to reset breaker or outlet until the problem has been identified and corrected.**

**NOTE: The ground fault outlet or breaker should be tested once a month to insure it is working properly. Use the “TEST” button on the outlet or breaker. It should trip with an audible “click.” The breaker or outlet will not trip if no AC power is present to the device. If power is present and the device will not “trip,” replace it before using that circuit.**

**NOTE: One mil is 1/1000 of one amp.**

---

### ***Tools of the Trade***

One of the most widely used tools for testing a 12 Volt problem is the test light. Test lights come in a host of varieties, such as a light bulb with a probe and ground clip, to the more elaborate electronic ones that measure a wide scale of voltages and perform a variety of functions. A VOM or Volt Ohm Meter is used to perform a multitude of tests. It is generally used when exact values are needed for evaluation. These meters come in an analog or digital format. Either of these two testing tools may be used, depending upon personal preference. If a 12 Volt light is not working, the test light may be better suited for this. In the case of a charging system problem the meter may be the tool of choice. In any situation the testing tool is an invaluable piece of equipment when it comes to determining an electrical problem.

---

### ***Know When to Say No***

If it is necessary to use testing tools, use precautions and consider three things. First, recognize when the problem is beyond your skill level. Nothing will create more problems than being armed with tools and going in an unknown direction. Good intentions can lead to major problems. The second item to consider is if something will cause more grief by being dealt with now than if it were left alone and repaired by a professional at a more convenient time. Items that seem as if they should only take a few minutes, may end up taking an entire day. The third item to consider is whether or not the current situation may be potentially dangerous if left to be repaired at a more convenient time.

**NOTE: Check all related fuses before assuming you have encountered an electrical problem or situation. Spare fuses should be kept on hand and can be purchased from auto parts stores. A fuse description label is on the distribution panel cover.**

**WARNING: If a fuse blows replace the fuse with same amperage rating and type. Installing higher amperage fuses can damage the wiring or the item the fuse is protecting, or may cause a fire. If the fuse repeatedly blows after replacing it do not continue to replace it. Have the problem diagnosed and corrected by a qualified technician.**

## **BATTERY - How it Works**

Batteries come in different sizes, types, amp hours, voltages and chemistries. Although it is not possible to cover batteries in their entirety, there are guidelines to be followed to ensure that the batteries are well maintained.

The operation of the battery is based on a chemical reaction. The battery contains of lead plates, insulators and a solution of distilled water and sulfuric acid. The solution is known as “electrolyte.”

The 12 Volt battery is actually six batteries in one case. When charged, each cell has a voltage of 2.1 Volts. When six cells are hooked together this makes a 12.6 Volt battery (fully charged).

Electrons are stored on the negative plates. When a load (eg. a light bulb) is put between the positive and negative terminals, the electrons move from the negative plate to the positive plate through the “load” and then back to the ground terminal. At this time the sulfuric acid leaves the water and adheres onto the plates of the battery. The electrolyte solution keeps the electrons from flowing while the battery is at rest.

Charging the battery moves the sulfuric acid back into solution with the distilled water. A battery left in a low or discharged state will cause the acid to sulfate. When trying to recharge the battery, the acid hardens and will not leave the plates and enter into the liquid solution. The lowered ratio has a direct affect on the battery ability to release the stored electrons (power output) and the length of time it can perform (reserve capacity). Batteries left discharged will readily freeze, which can crack the case allowing the solution to spill or warp the plates. The acid acts like antifreeze for the battery, which is why batteries should not be left or stored discharged.

---

### **Battery Types**

**Starting Batteries:** Starting batteries are designed for high output cranking power, not deep cycling like the house batteries are designed to do. Starting batteries will not last long in deep cycle application. The way they are rated should give a good indication of their intended use. “Cold Cranking Ampere” is a measurement of amperage output that can be sustained for 30 seconds. Starting batteries use thin plates to maximize the battery surface area, allowing a very high starting current, while allowing the plates to warp when the battery is deep cycled (discharged).

**Deep Cycle Batteries:** Deep cycle batteries are best suited for use with 12 Volt operated lights, appliances and inverters. The most common type is a non-sealed, liquid electrolyte battery. The non-sealed types have battery caps. The caps should be removed periodically to check the level of electrolyte. When a cell is low, only distilled water should be added. Water consumption will vary depending on many factors: how far the batteries are depleted, how long the voltage is being applied to charge the batteries, how much voltage is used and how often this occurs. Generally, the batteries should be checked every two or three weeks when continuously hooked to shore power.

**NOTE: Tap water contains minerals which can alter battery chemistry and ruin the battery. Use only distilled water when refilling the battery.**

**NOTE: Batteries should not be drained past 50% of their capacity often, the life of the batteries may be shortened.**



## Testing the Battery

There are several ways that a battery can be tested and monitored. The motorhome uses a monitor panel that shows the status of the batteries at a quick glance. Press and hold the test switch to display the desired battery bank voltage.

**Checking Electrolyte Solution:** A more efficient way of testing the batteries is to check the electrolyte solution. The only way to test a battery's electrolyte solution is with a hydrometer. Hydrometers can be purchased from most auto parts stores.

Many styles are available, from types with cylinder graduation (shown here) to types with floating balls. The hydrometer tests the battery's electrolyte solution which is measured in specific gravity. Distilled water has a specific gravity of 1,000. The hydrometer is calibrated to this mark. Pure sulfuric acid has a specific gravity reading of 1,840. The acid is 1.84 times heavier than water. The electrolyte solution is about 64% water to 36% acid (fully charged battery). Hydrometers with cylinder graduation are graphed and the exact state of specific gravity can be determined. Temperature and recent battery activity (charging or discharging) affect the hydrometer readings. It is best to check the battery when it has been "at rest" for at least three hours, although readings taken at other times will give a "ballpark" figure. When using the hydrometer, draw the electrolyte solution up into the tube. Allow the hydrometer to attain the same temperature as the electrolyte solution. Note the reading for that cell. Complete the same test for the rest of the cells on that battery bank.

The hydrometer is calibrated at 80° F. Temperature affects the hydrometer readings. The higher the electrolyte temperature, the higher the specific gravity reading. The lower the temperature, the lower the specific gravity reading. Add or subtract four points for each 10° variance from the 80° F chart. Readings between cells should not vary more than 50 points.

If one cell in a particular battery bank being tested is at a 50% state of charge while the others are indicating a full charge, charge only that battery to see if the low cell will come up. At the same time, do not over charge the "healthy" cells.

If the low cell does not come up after charging, this battery can damage the rest of the battery bank and should be replaced. An accurate digital volt meter + - .5% will also give an indicator of the battery's state of charge.

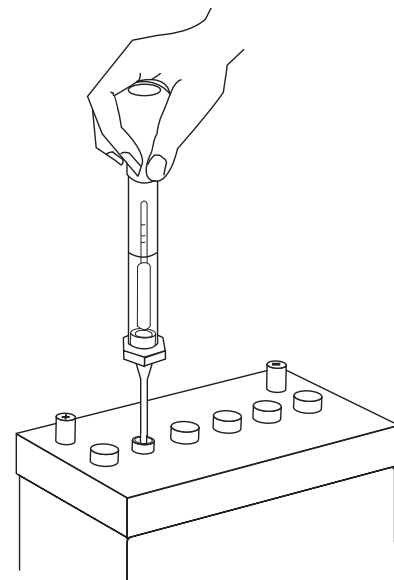

030816

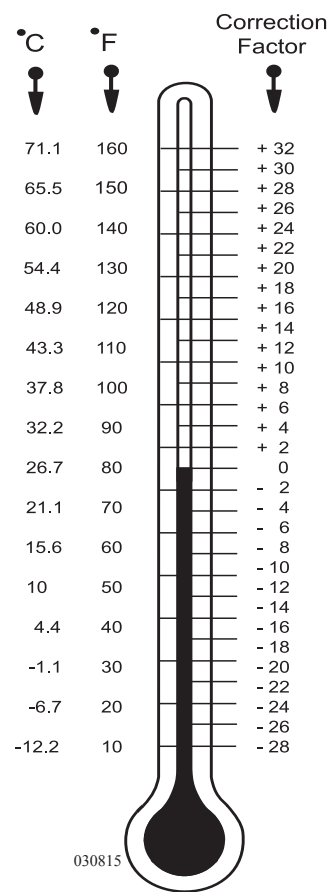

030815

Temperature  
Compensation Chart

**Placing Load on Batteries:** Another test that can be performed is to place a specific load on the battery for a predetermined length of time equal to that particular battery's rating. This machine is usually an adjustable carbon pile that can vary the load being applied to the battery(s) while monitoring voltage to see if they will perform to their specific rated capacities.

**NOTE:** See the Temperature Compensation Chart. Liquid levels should be even between the cells of the battery being tested as it will affect the accuracy of the test.

**WARNING:** Sulfuric acid in the batteries can cause severe injury or death. Sulfuric acid can cause permanent damage to eyes, burn skin and eat holes in clothing. Always wear splash-proof safety goggles when working around the battery. If the battery electrolyte is splashed in the eyes, or on skin, immediately flush the affected area for 15 minutes with large quantities of clean water. In case of eye contact, seek immediate medical aid. Never add acid to a battery once the battery has been placed in service. Doing so may result in hazardous splattering of electrolyte.

---

## Battery Maintenance

At a minimum, the battery electrolyte level should be checked at least once a month. Check the level sooner if the battery is frequently used. The level should be above the top of the plates, but not overfull. Most batteries have a plastic cup or well. The electrolyte level should be about 3/8" below the well to allow room for expansion while the battery is being charged. Over-filling the battery will allow the electrolyte solution to boil or gas out of the battery cap. Remember to use only distilled water to refill the battery. A battery with a low electrolyte level will boil the water out rapidly once the plates have been exposed to air. This process may take only a matter of hours. If this has happened the battery is more than likely damaged.

After checking the battery's electrolyte levels it is also a good idea to check the battery connections for tightness and corrosion. If any corrosion is found disconnect the cables (make sure to mark their locations) and carefully clean them with a mild solution of baking soda and water. There are also aerosol products available that will work. This will neutralize any acid that may be present. Do not allow the solution to enter the battery as this will damage the electrolyte balance. Use water to rinse the top of the battery and surrounding area when done. Carefully hook the cables back to the battery. Coat the terminals with petroleum jelly or an anti-corrosion grease.

The battery cable to battery terminal connections should be metal to metal. Periodically check the batteries for corrosion. Look for cracks and check the vent plugs. Replace them if they are cracked or missing. Keep the top of the batteries clean. The accumulation of electrolyte and dirt may permit small amounts of current to flow between the terminals, which can drain the battery.

**WARNING:** Liquid lead acid batteries produce highly explosive hydrogen gas when charging. Do not smoke around batteries. Extinguish all flames in the area. The hydrogen gas may explode resulting in fire, personal injury, property damage or death.



*Wear safety glasses when servicing the battery.*

---

**Battery Voltage & Current**

Why does the voltage on a discharged battery measure the same as a fully charged battery until the loads are applied? The simple answer to this might go as follows: A battery creates electrical power by converting energy from a chemical reaction into electrical energy. As this reaction slows down the battery voltage will drop. In a lead acid battery the electrolyte conductivity (how well electrical current can flow through it) changes. The same current may be available but the rate of the reaction decreases, causing a voltage drop.

Another way of looking at this is to use the analogy of a water pump (a battery is an electric pump). The pressure in psi (pounds per square inch) that a pump delivers is like a battery's voltage. The volume of water in GPM (gallons per minute) is like the electrical current. Look at a 12 psi pump with no loads (the pump is running but the outflow valve is turned off). The pump will run and the internal pressure of the pump will build up to some point higher than 12 psi. When the valve is opened, and the water is free to flow into the loads, the pressure will drop to the rated output pressure of 12 psi, but only if the load is not too big. If the pump is designed to maintain 12 psi at 15 GPM, and a load demanding 20 GPM is connected, the pump will not be able to keep up and the pressure will get sucked down to a lower psi. If the load is reduced or removed the pump will catch up and return to its rated 12 psi pressure. If the pump has an infinite source of water, such as a lake or the water utility (this is like the grid, no battery), the pump will never run out of pressure. If the pump never runs out of pressure, and is operated at or below its 15 GPM level, it will hold 12 psi. However, a pump that is connected to a water tank with a finite capacity will start to lose the ability to hold pressure as the level of water in the tank drops. Think of siphoning water from a bucket. As the level of the water drops, the volume of water exiting the siphon slows down.

When the tank is full it is capable of feeding more "pressure" to the pump inlet due to gravity, and the pump always has enough water available to maintain its rated pressure and volume. However, if the water tank gets low the pump will not have enough water volume coming in to maintain 12 psi at 15 GPM. If the loads are removed from the pump by closing the valve on the outflow, even with low pressure in the tank the pump will eventually pressure up to 12 psi. It will just take it longer to get there. When the valve is opened the pump will sustain 12 psi for a brief period, but since the tank is no longer feeding the pump as fast as needed the pressure will eventually drop. This analogy can be restated by replacing the pump with a battery, pressure with voltage, volume with amps, outflow valve with a switch, water with electricity and the water tank with the battery electrolyte.

The level of the tank could be thought of as the rate of the reaction occurring in the electrolyte. When the battery is fully charged the electrolyte has an excess of reactions taking place to feed the battery terminals. This tapers off with time as the electrolyte is spent, so maintaining voltage becomes possible. With no loads, the discharged electrolyte is capable of producing close to the rated voltage, but only after a period of time has elapsed for enough of a reaction to take place to bring the voltage back up. This explains why a battery measured at rest can indicate close to its rated voltage, but will not run a load.

## **Battery Charge Time & Consumption Rate**

**Calculating Run Times:** Calculating run time figures when operating 120 Volt AC electrical items with an inverter/converter can be exponential because of battery characteristics. Flow characteristics of electrons vary with different battery types and chemical compositions. Deep cycle batteries are generally designed to slowly release a majority of their charge capacity. Deep cycle batteries are rated in amp hours (Ahrs) with the discharge occurring over an extended period of time before the battery is charged. Engine starting batteries are designed to quickly release large amounts of current for short durations, without depleting battery reserves. Commercial type batteries bridge the gap between deep cycle and engine batteries. Commercial batteries release medium amounts of current over a longer period of time but they are not designed to cycle their charge capacity.

The working range of a deep cycle battery is between 50 and 100% state of charge (SOC). Deep cycle batteries should not be cycled below 50% state of charge. Discharging a deep cycle battery below 50% state of charge shortens the life of the battery. Deep cycle batteries use an amp hour rating which is usually calculated over a 20 hour discharge interval. For example: A deep cycle battery with a rated capacity of 100 Ahrs is designed to release current at the rate of 5 Amps per hour. When multiplying a 5 Amp load by a 20 hour discharge period, the sum equals the rated 100 Ahr. capacity. These discharge figures are calculated with the battery starting at 100% state of charge with the battery at 80° F when the discharge cycle begins. However, increasing the discharge load applied to the battery from 5 Amps to 10 Amps on a 100 Ahr battery does not yield 10 hours of discharge time. This is due to the internal reactions which occur when a battery is discharging. Actual discharge time for a 10 Amp load may be closer to eight hours of discharge time. Increasing the load applied to the battery to 20 Amps will not yield 5 hours discharge time but may be less than 3 hours. It might be understood as a point of diminishing return.

Calculating applied loads to an inverter/converter to approximate run time from the battery amp hours available is not an equal trade up when voltage is inverted and amperage is calculated. When the inverter/converter is used to operate an AC load it uses about ten times the DC current needed from the battery when inverting 12 Volts to operate the 120 Volt item. A small efficiency loss of about 10% occurs when inverting. For example: When using the inverter/converter to operate an AC electrical item, which has a current draw rating of 2 Amps, the inverter/converter will use over 20 Amps DC power from the batteries.

**Determining Current Consumption:** Determine the amount of current used by an AC item. For example: The television is rated at 200 watts at 120 Volts. Calculate watts to amps. Divide 200 watts by the operating voltage of 120, this equals 1.6 Amps. Multiply 1.6 Amps AC current by a factor of ten the inverter/converter will use, this equals 16 Amps DC battery current. Add the revised 10% efficiency loss figure with a sum of 17.6 Amps DC. If the battery bank capacity is rated at 500 Ahrs., actual elapsed time to the suggested 50% state of charge would net viewing time for the television at about 13 hours in ideal conditions.

The run time figure will vary greatly with the actual state of charge of the battery bank when the discharge process begins. Ambient temperature, combined with other working loads (lights and parasitic loads applied to batteries) affect run times. Calculating the run time is not precise due to the variables and equations involved; however, an approximate time figure can be obtained. Proper battery maintenance and charge cycles affect battery performance.

Observe the battery condition with hydrometer and voltage readings. Use only distilled water when filling batteries. To achieve the highest quality of battery performance and longevity keep batteries in their proper operating range.

**Electrical Layout**

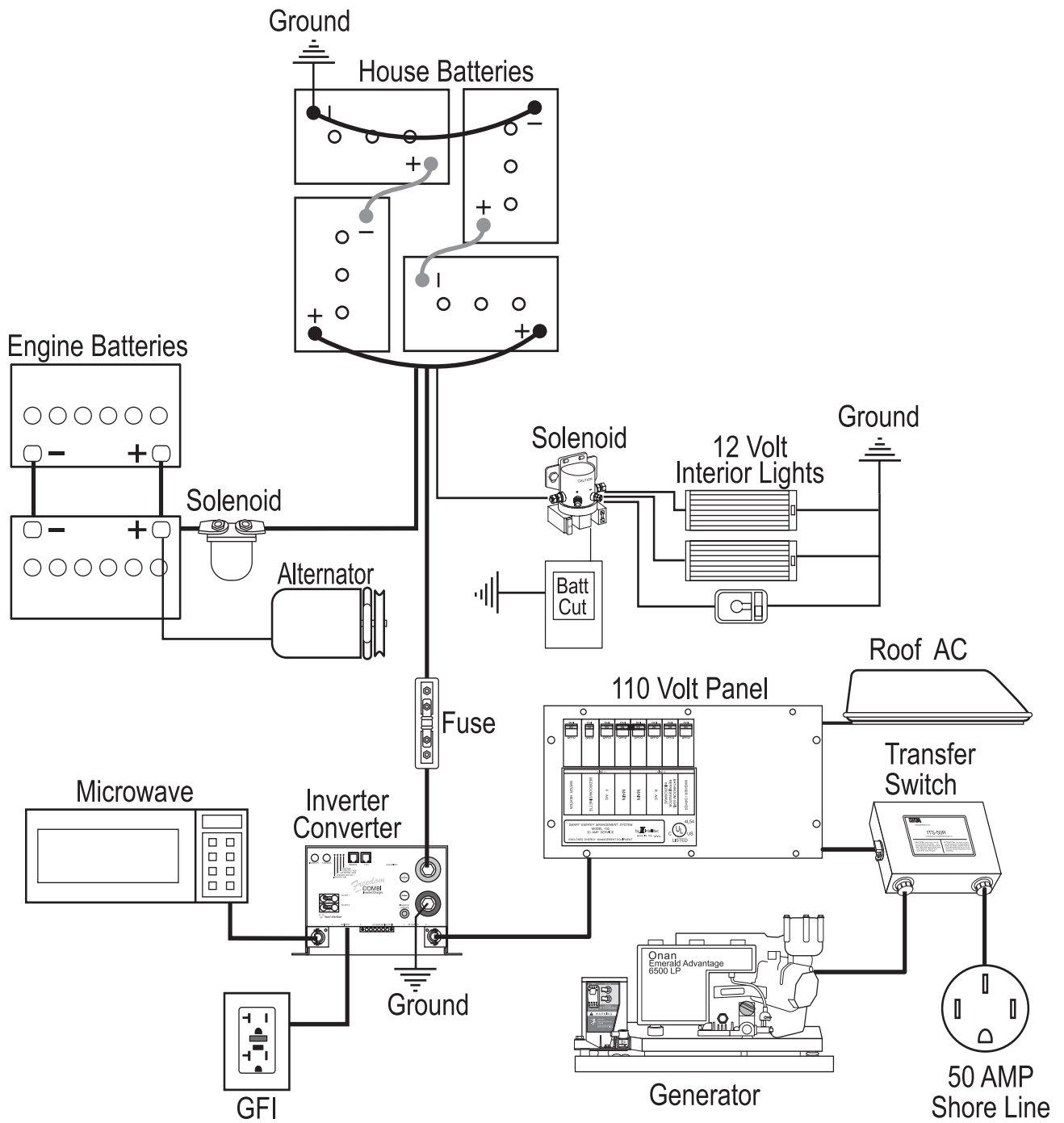

0600191e



# *Electrical Systems - Chassis*

## *Section 9*

<b>ELECTRICAL CHASSIS - INTRODUCTION</b> .....	<b>289</b>
<b>BATTERY DISCONNECT - CHASSIS</b> .....	<b>289</b>
<b>BATTERY - CHASSIS</b> .....	<b>290</b>
<b>DASH</b> .....	<b>291</b>
Indicator Lamps .....	291
Gauges.....	292
Parking Brake .....	294
Switches .....	294
Controls .....	297
<b>AIR CONDITION &amp; HEATER CONTROLS</b> .....	<b>298</b>
About Refrigerants.....	303
<b>STEERING COLUMN</b> .....	<b>306</b>
Tilt & Telescope .....	306
<b>FUSE &amp; CIRCUITS</b> .....	<b>307</b>
Front Distribution Panel.....	307
<b>ALTERNATOR</b> .....	<b>309</b>
Check Out Procedure.....	309





## ELECTRICAL CHASSIS - INTRODUCTION

A majority of the lighting and appliances are designed to operate from 12 Volt DC (direct current) power. This is why batteries play such an important role in the function of the motorhome. There are exceptions with appliances such as the microwave or television; however, indirectly they still operate from 12 Volt DC power, as they can be operated from the inverter. The chassis functions (engine, transmission, dash air, etc.) are also 12 Volt DC.

With the all technological advancements taking place in the past several years manufacturers have now incorporated electronics into these systems. It is important to keep the 12 Volt system(s) in good working order. These systems, with their incorporated electronics, are voltage sensitive. Some items can be damaged if the DC voltage is not maintained within the designed specifications.

There are two separate 12 Volt systems. One is the chassis system; the other is the house system. These two systems, for the most part, are separate from one another. The house system does not operate engine functions; as the engine system does not operate house functions. However, within the two systems there are some inner connections. For example: While the motorhome is driven the alternator on the engine will surface charge the house batteries. Each system will supply 12 Volt DC power to the 12 Volt distribution panels.

The two different systems, engine and house, have their own set(s) of battery(s). The engine battery supplies 12 Volt DC power to the front distribution panel located in an outside compartment by the driver's side front wheel. This panel contains mostly engine system fuses and wiring such as headlights, taillight, dashboard functions, gauges, etc. The house battery(s) supplies 12 Volt DC power to the distribution panel located in the bedroom. This panel contains fuses for the house, interior lighting and appliances, such as the furnace and water heater.

## BATTERY DISCONNECT - CHASSIS

The main battery disconnect for the chassis battery turns the DC power on or off to the front electrical bay. Chassis and engine functions are interrupted when the battery disconnect is turned off. Some electronic items require a constant power source for memory retention such as the dash and CB radios. Some electronic components of the engine and transmission require a constant power source. Turn the main battery disconnect switch off when the motorhome is going to be stored, or when performing electrical maintenance.

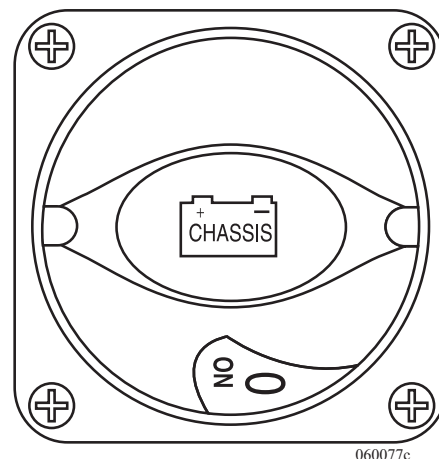

060077c

**NOTE:** The solar panel (optional) will charge the batteries with the disconnect switch off.

**WARNING:** When welding is involved for motorhome repair or modification, only qualified, experienced technicians should weld on the chassis. Improper welding procedures and materials may weaken the assembly or result in damage that is not obvious and may not cause an immediate problem or failure. Unauthorized modifications or repairs to the chassis could result in a forfeiture of warranty coverage.

**DANGER:** Due to the sensitive nature of the electronics on the chassis, the following precautions are required to protect electrical components in the motorhome chassis:

1. Disconnect the (+) positive and (-) negative battery connection.
2. Cover electronic control components and wiring to protect from hot sparks.
3. Disconnect the terminal plugs from the engine Electronic Control Unit, located on the passenger side of the engine block.
4. Disconnect all the plugs from the transmission Electronic Control Unit, located in the storage bay between the frame rails.
5. Disconnect the wiring from the alternator.
6. Do not connect welding cables to electronic control components.
7. Attach the welding ground cable no more than two feet from the part to be welded.

---

## **BATTERY - CHASSIS**

The chassis battery operates only chassis and engine functions. The chassis battery is a crank type battery, producing the high amperage needed to start the engine. Engine starters initially require a large amount of current to crank an engine. Initial starter amperage draw exceeds 1200 amps. The type of application in which the engine battery is used differs from the house battery application. The engine battery state of charge remains consistent. Maintenance is still required with an engine battery. Regular electrolyte level checks and hydrometer readings should be performed. High electrolyte consumption, or inconsistent hydrometer cell readings, may indicate a charging system problem. Perform a charging system and current draw check if the battery is exhibiting abnormal hydrometer readings.

**NOTE:** Replacement batteries should have the same cold cranking amp (CCA) rating.

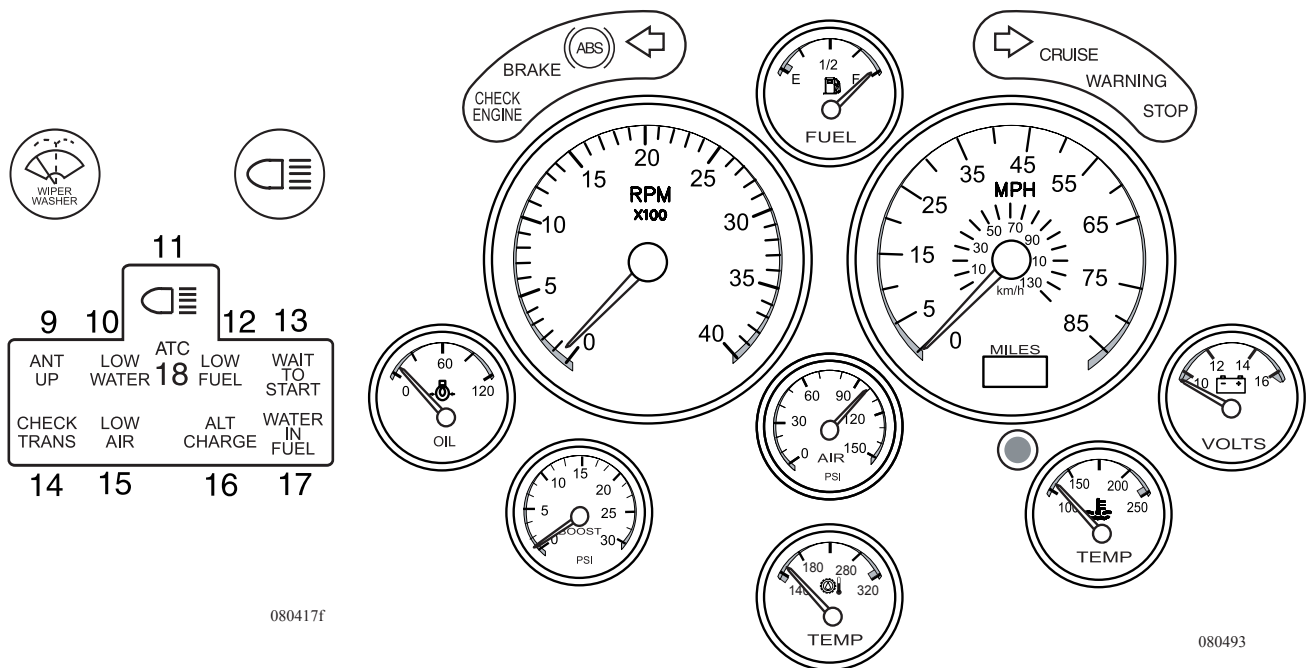
**DASH - Indicator Lamps**

080417f

080493

1. **CHECK ENGINE:** Problem with the engine.
2. **PARK BRAKE:** Parking/emergency brake is applied.
3. **ABS:** Possible fault in the ABS Brake system. Also indicates fault codes for service technicians.
4. **LEFT TURN** - Indicates when turn signal is activated..
5. **RIGHT TURN** - Indicates when turn signal is activated.
6. **CRUISE:** Indicates when cruise control is activated.
7. **WARNING:** Out of range conditions exist within the engine protection circuits. Stop coach, check all fluid levels.
8. **STOP ENGINE:** Alerts driver of severe out of range condition within the engine protection circuits. Pull over and stop as soon as possible. Shut-off engine to avoid engine damage.
9. **ANT UP:** TV antenna is raised. Lower antenna before moving coach.
10. **LOW WATER:** Coolant level in the overflow tank is below acceptable level.
11. **LOW FUEL:** Fuel level is becoming low.

12. **HEADLIGHT BEAM:** High beams when illuminated.
13. **WAIT TO START:** Monitors the air intake heater at engine start up.
14. **CHECK TRANS:** Alerts driver of Allison Transmission problems. The light should momentarily illuminate when the ignition is switched ON and extinguish to indicate the properly working circuits. If the lamp fails to illuminate or remains on, the transmission needs to be checked by the nearest Allison dealer.
15. **LOW AIR:** Air tank pressures are out of operating range. Check air pressure.
16. **ALT CHARGE:** Failure within the alternator charging system.
17. **WATER IN FUEL:** Water has been detected in fuel.
18. **ATC:** The ATC indicator light will illuminate steady when the ignition key is turned ON. The light remains illuminated until the first brake application. The indicator flashes slowly when the switch is pressed to indicate the ATC is activated. The indicator light will flash quickly when an ATC event occurs.

## Gauges

1. **TURBO BOOST:** Boost pressure produced by engine turbocharger.
2. **WATER TEMP:** Under average conditions the gauge reads between 180° F and 205° F. Monitor this gauge frequently when CLIMBING HILLS, TOWING or in HIGH AMBIENT TEMPERATURES. If the gauge shows that over-heating exists (the needle moving above the 212° F area) IMMEDIATE ACTION should be taken.

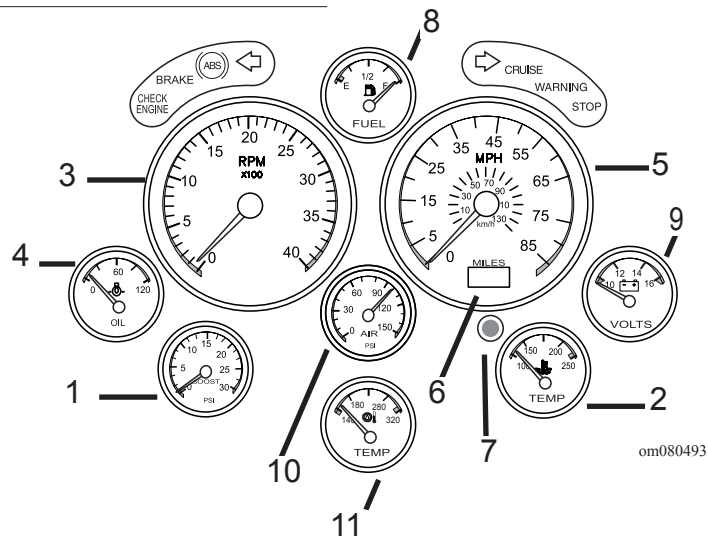

### Overheating may be a Result of any of the Following Conditions:

- Low coolant level.
  - Mechanical failure of hoses or belts.
  - Blocking of charge air cooler fins.
  - Climbing a long hill on a hot day.
  - Towing a heavy trailer.
  - Idling for long periods of time.
3. **TACHOMETER:** Displays engine speed in revolutions per minute (RPM).
  4. **OIL PRESSURE:** Indicates oil pressure oil, not the amount of oil in the engine.

---

Please refer to manufacturer's instructions for specific pressure recommendations.

**NOTE:** When operating the engine cold, the pressure will be considerably higher due to increased viscosity (thickness) of the oil.

**WARNING:** If the oil pressure drops significantly below 35 psi while driving or 10 psi while idling, stop the engine and check the oil level.

5. **SPEEDOMETER:** Indicates the speed of the motorhome. The gauge indicates MPH and KPH.
6. **ODOMETER/TRIP METER:** Used to toggle between the odometer and trip meter. Holding the button down for two seconds will reset the trip meter.
7. **MILEAGE/TRIP RESET BUTTON:** Operates the trip meter, changes the odometer mileage reading to the trip mileage reading. Press and hold to reset the trip meter.
8. **FUEL:** Fuel gauge will register approximate fuel level in the tank when ignition switch is in the run position.

**NOTE:** Fuel mileage varies with driving style and road conditions. Always average more than one tankful to obtain a more accurate figure. The diesel Generator uses fuel from main tank and will affect fuel mileage figures. Diesel Generators will not operate below 1/4 tank to ensure there is enough fuel to run main engine.

9. **VOLTMETER:** Shows the charge condition in the chassis battery. The normal voltage with the ignition switch ON and the engine OFF varies between 12.0 and 13.0 Volts. With the engine operating without a heavy load the battery charging voltage is about 14.0 Volts. Battery readings of less than 10.5, or more than 15.0 Volts, usually indicates a battery or electrical system problem.
10. **AIR PRESSURE GAUGE:** Uses two needles to indicate air system pressures. One needle indicates air pressure of the front air tank. The other needle indicates air pressure of the rear air tank. The normal air system operating pressures are 105 to 120 psi. These air pressures are preset at the factory. If a problem occurs with either system not maintaining normal operating pressure, it is an indication of a malfunction in the air system. Use caution and stop the motorhome in a safe area. Contact a qualified technician immediately.

**NOTE:** It is not safe to drive the motorhome with low air pressure. Damage can occur to the suspension and drive shaft and can also affect operation of the air brake system.

11. **TRANSMISSION TEMPERATURE:** Indicates temperature of transmission fluid. Running temperature is about 170 to 175° F

## Parking Brake

The parking brake system is activated when the push-pull control knob (located on the driver's left console panel) is pulled. When the knob is pushed, the brake is released. Prior to driving, allow time for the air compressor to build up sufficient air to shut off the air warning lamp.

**WARNING:** If the air tank is not dumped, there is the possibility of an accidental release of the parking brake. Traveling with small children and/or pets may require a small block to be fabricated to prevent accidental release. The block should be placed under the knob and rested on the dash panel. A wooden clothes pin clasped at the base of the shaft will work and is not shipped with the unit.

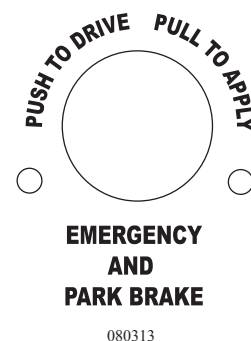

## Switches

There are two types of switches used, both lighted, but one utilizes a function "ON" indicator. Each switch has the function it controls printed on the switch. Press the top of the switch to start the function and press the bottom to stop the function. Following is a list of switches used and their functions.

**PEDAL IN/OUT:** After sitting in the driver's seat and making adjustments to the mirrors and steering wheel, use the Pedal In/Out switch to adjust the brake and throttle pedals to be either closer or farther away. Locate the switch on the driver's console panel marked Pedal IN/OUT. The switch moves the pedals inward or outward approximately three inches. If you need to move the pedals inward, just push the switch. When the pedals reach the end of their traveling distance, the pedals will automatically stop. Release the switch.

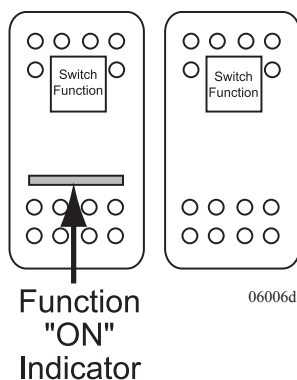

**BATT BOOST:** In the event the motorhome chassis battery has been drained and cannot start the engine, this switch momentarily "jumps" the domestic battery to the motorhome chassis battery to assist in starting the engine.

**FOG LIGHTS:** Turn fog lights ON and OFF for better visibility. The fog lights will operate with the Low Beam of the headlights.

**ATC SYSTEM:** The ATC system improves traction on slippery or unstable surfaces by preventing excessive wheel slip (see Section 10 for detailed information).

**EXHAUST BRAKE:** Auxiliary braking device for slowing down the motorhome. For flat dry road conditions apply the exhaust brake until speed is reduced. The exhaust brake is effective for speed control in town and on local routes. Use the exhaust brake to slow down when preparing to exit onto an off-ramp, when approaching traffic lights or when approaching slowed or stopped traffic. The exhaust brake is not a substitute for the service brakes. Do not neglect service brake maintenance.

**NOTE:** Some municipalities have ordinances banning the use of the exhaust brake. Be sure to check road signs in densely populated areas.

**MIRROR HEAT:** The switch turns on the heaters in outside rearview mirrors. The mirror heaters should be used when defogging or deicing as needed. To use the mirror heat, press the switch to the ON position.

**NOTE:** Mirror heat should not be left ON unless continuous fogging conditions occur.

**AIR DUMP:** Will manually dump air from the air bags. May be an aid in leveling the motorhome. Releasing the air from air bags will give the leveler more range of travel for leveling. Ignition must be in accessory or run position.

**NOTE:** Never drive the motorhome with the air bags deflated. This may damage the motorhome.

**GEN START:** The generator automatically initiates a preheat cycle when the switch is pressed to START. The preheat cycle cycle is indicated by the light on the switch flashing rapidly. Depending on ambient temperature the preheat cycle may last up to 15 seconds.

**To Start the Generator:** Press and hold the switch to START. The light will flash rapidly indicating the preheat cycle. At the end of the preheat cycle the engine will crank and start. Release the switch after the generator has started and is operating smoothly.

**To Stop the Generator:** Momentarily press the switch to STOP. It is not necessary to hold the switch until the generator has stopped.

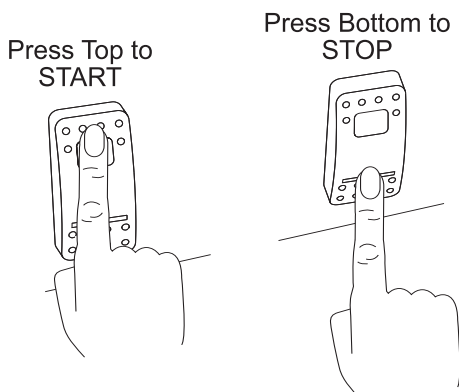

080357



**ENTRY STEP:** Provides power to operate the Entry Step.

**STEP COVER:** Extends and retracts the step cover.

**PORCH LIGHT:** Turns ON and OFF the outside Porch Light.

**RADIO:** Applies power to the dash radio. This will allow the radio to be turned ON and OFF, independent of the main radio switch.

**DRVR SHADE:** Operates the power sun visor located on driver's side.

**PASS SHADE:** Operates the power sun visor located on passenger side.

**CEILING LIGHT:** Illuminates the front ceiling light from the Entry Area.

**BATTERY CUTOFF:** Controls the 12Volt DC power to the domestic fuse panels.

**CRUISE ON/OFF:** Turns cruise ON or OFF.

**CRUISE CANCEL:** Signals the cruise system to disengage without losing the current speed memory.

**RESUME/SET:**

- Cruise SET - Actuates the Cruise Set function of the engine controller.
- Cruise RES - Actuates the Cruise Resume function of the engine controller.

**NOTE:** The cruise control system will not operate with the exhaust brake engaged.

**WARNING:** To take control of the motorhome do not use cruise control in heavy traffic or on roads that are winding, slippery or unpaved. Do not shift the transmission into "N" (Neutral) with the cruise control on as high engine RPM run up will occur until the cruise control is turned off.

**STORAGE LIGHT:** Operates lights within the compartment bays.

**STEP LIGHT:** Provides power to the exterior amber step light.

**ICC FLASH:** Flashes all exterior lights at once.



**MIRROR ADJUST:** To adjust the rear view mirror the small selector in the middle of the switch must be placed in the desired side. The middle position is to prevent accidental bumping of the switch and changing the mirror position. The outside mirrors have been placed so that they can be easily adjusted with the Allen wrench. After taking delivery of the new motorhome it will be necessary to sit in the driver's seat and adjust the mirrors to driver's needs. Both the driver and the passenger mirrors should be adjusted.

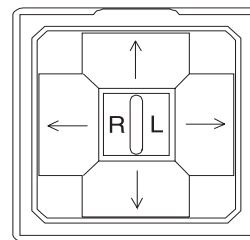

060097

**HEADLIGHT:** Pull one click to operate the parking lights. Pull two clicks to operate the headlights. Rotating the headlight switch clockwise will dim the dash lights. Counterclockwise rotation will illuminate the map light in the overhead compartment.

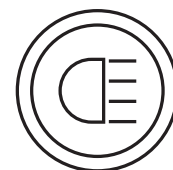

080332

Headlight Control

**WIPER/WASHER:** Wiper operations are controlled when rotating the knob to the right. When the knob is rotated from OFF to DELAY, the wiper will turn on and time delay between wipes (ranging from 45 seconds to two seconds) will occur. The amount of delay time changes as knob is rotated. A continuous low or high speed can be obtained by rotating the knob to the appropriate position. The wipers will be turned OFF with the switch in the OFF position. When the end of the knob is pushed in, water fluid will be dispensed from the system and the wipers will turn on momentarily.

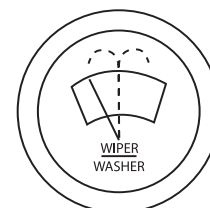

080339

Wiper/Washer Control

**BACKUP MONITOR:** Used with the back up camera and will display the rear view of the motorhome.

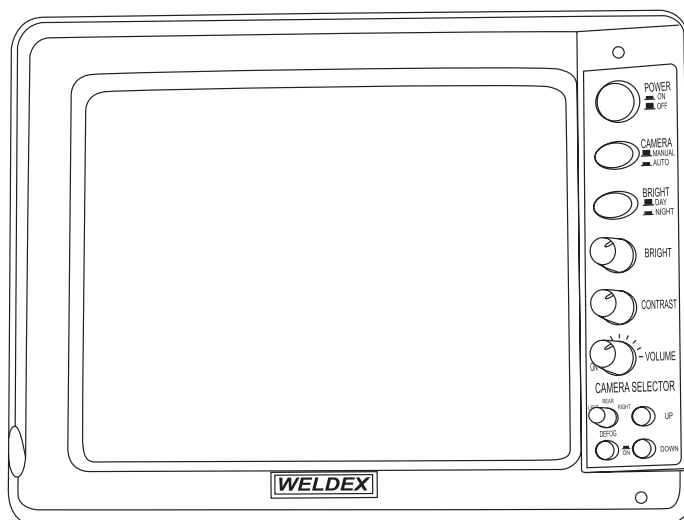

031156

## AIR CONDITIONER & HEATER CONTROLS

The system is designed to only provide heating, cooling and defrost for the pilot and co-pilot area. The system is not capable of heating or cooling the entire motorhome.

**Blower Control Switch:** This switch controls the four speeds of the blower motor. This is one of the best and most effective ways of controlling temperature. The blower will not activate until the Mode Control Switch is set to any position other than Off.

**Temperature Control Switch:** Setting the switch to the Red zone controls an electric water valve regulating the amount of engine coolant passing through the heating coils in the system. Rotating to the blue zone sets the cut-in/cut-out temperature of the air conditioning compressor on the engine.

**Mode Control Switch:** This switch directs air flow by opening or closing damper doors. Use the Mode Control Switch to direct airflow where it is needed to maximize comfort in the cockpit area.

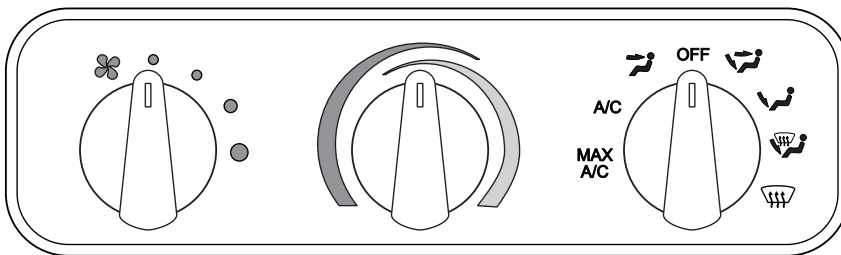

080221

Blower Speed Control    Temperature Control    Mode Control Switch

**MAX A/C** - Recirculated air is drawn from the passenger area and discharged through the dash louvers.

**A/C** - Fresh Air is drawn from outside into the system and discharged through the dash louvers.

**VENT** - Fresh air is drawn in and discharged throughout the dash louvers.

**OFF** - The blower motor does not operate. The fresh air inlet door will close, minimizing outside air infiltration into the motorhome.

**BI-LEVEL** - Fresh air is drawn in and discharged through the dash and the floor louvers.

**FLOOR** - Fresh air is drawn in and discharged through the floor louvers. A small amount of air discharges through the defrost vents.



090277B

**MIX** - Fresh air is drawn in and discharged through the floor and defrost louvers. The A/C system operates to dehumidify the discharged air.



**DEFROST** - Fresh air is drawn in and discharged through the defrost louvers. The A/C compressor operates to dehumidify the discharged air.

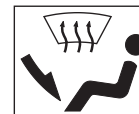

**Heat and Defrost Operation:** The air conditioning compressor operates in all modes except **VENT**, **FLOOR** and **OFF** to dehumidify the air. Rotate the temperature control switch to set discharge air temperature.

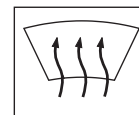

090277B

- Set the Mode Control Switch to the desired position.
- Set the Temperature Control Switch to the red zone.

**A/C Operation:** The air conditioning compressor operates in all modes, except vent, floor and off, to dehumidify the air. Rotate the temperature control switch to set discharge air temperature.

- Setting the Mode Control Switch to **A/C** will allow outside air into the system.
- Setting the Mode Control Switch to **MAX A/C** will recirculate inside air. When maximum cold air is desired, select this position.
- Set the Temperature Control Switch to the blue zone.

**NOTE:** The temperature control switch must be set to the blue zone for cool air.

**NOTE:** Activate the A/C system monthly to keep internal components of the compressor lubricated.

#### Winter Use:

- De-ice the windshield using the DEFROST mode.
- The system will heat up faster with a slower blower speed until normal engine operating temperature is obtained.

#### Summer Use:

- Close all windows and vents preventing hot and humid outside air from entering the motorhome.
- MAX A/C and HI blower will provide quick cool down.
- Using a lower blower speed will produce cooler air.

**Operating Tips and Hints:**

- Air intake and discharge temperatures are greatly effected by ambient temperature and relative humidity.
- A large amount of cooling capacity is used to dehumidify air as well as cool it. After three to five minutes of A/C compressor operation, the discharged air temperature should be approximately 30° F cooler than the fresh or recirculated air entering the A/C system.
- The air system on the motorhome must have adequate pressure to operate the vacuum generator or damper doors will not function.
- At the beginning of the day, activate the compressor with the engine at idle. This will avoid sudden high speed activation resulting in damage from lack of internal compressor lubrication.
- The dash A/C and heater system should be used monthly to keep the compressor lubricated.

**Trouble Shooting:** The dash A/C/Heat system uses a combination of compressed air (developed by the chassis system), vacuum air (developed by the vacuum generator) and electric relays and vacuum switches. Therefore, any repair can be classified in one of five categories:

- **Electrical** • **Vacuum** • **Air Conditioner** • **Heater** • **Defroster**

The following information is provided to assist in troubleshooting common operational problems which may occur.

**No Heating:**

1. A/C switch is turned off.
2. Blower switch is turned off.
3. Verify the proper engine coolant level.
4. Verify that the engine is reaching operating temperature.
5. Verify engine coolant is reaching water valve attached to unit.
6. Verify operation of water valve to permit engine coolant to pass through valve to heater core.
7. Check unit fuses.
8. Check power supply to water valve and grounding.
9. Check wiring.
10. Engine thermostat faulty.

**No Cooling:**

1. Check blower is operating, A/C switch is in **A/C** or **Max** position, temperature control is turned to Max cooling (blue area).
2. System fuses are not blown.
3. Condenser fan is operating.
4. Check power supply to unit and grounding of system.
5. Check wiring.
6. Coolant valve is leaking.
7. Drive belt is loose or broken.
8. Compressor Clutch is inoperative, will not engage.
9. Expansion Valve is faulty or frozen.
10. Thermostat control is faulty.
11. Mode control switch is faulty.
12. Compressor is faulty.
13. Loss of refrigerant.

**Reduced Cooling:**

1. Coolant valve not operating correctly.
2. Air passages are obstructed.
3. Loose or worn drive belt.
4. Check blower and select switch.
5. Thermostat control valve is faulty.
6. Expansion valve is faulty.
7. Compressor is faulty.
8. Low refrigerant charge.

**Blower Does Not Operate or Runs Slow:**

1. Check fuses.
2. Check for loose or corroded connection.
3. Check wiring.
4. Check to ensure ignition switch is “ON.”
5. Check blower and select switch.
6. Motor shaft has seized.
7. Blower wheel is out of alignment.

**Damper Doors Do Not Operate:**

1. Does the motorhome air tank have pressure?
2. Is the vacuum generator being powered and producing a vacuum?
3. Check the vacuum line entering the unit for vacuum.
4. Check that the vacuum solenoid mounted on unit is receiving power from the mode switch. If operating properly, the vacuum solenoid will feel hot if current is engaging the solenoid.
5. Check the mode switch.
6. Check wiring.
7. Check for a pinch in the vacuum line leading to the vacuum motor that operates the damper door in question.

**Air Conditioner Refrigeration Components:**

**Compressor** - The compressor is belt driven from the engine through the compressor and electronic clutch pulley. The compressor will pump freon from a low pressure gas into a high pressure, high temperature gas. This is the start of the refrigeration process.

**Condenser** - The condenser in front of the radiator is made of coils and fins which provide rapid transfer of heat from the refrigerant as external air passes over the coils. The high pressure gas is changed to a high pressure liquid.

**Condenser Fan** - A steady flow of cooling air is maintained across the condenser during system operations. The fan is part of the hydraulic system.

**Receiver-Drier** - Freon leaves the condenser, enters the dehydrator and is stored until needed. The drier filters out moisture in the system. It only takes one drop of moisture to cause a malfunction in the cooling unit.

**Expansion Valve** - The expansion valve suppresses the refrigerant into the evaporator according to the cooling requirements. The pressure is reduced in the restrictive effort of the expansion valve. A part of the valve is the capillary tube assembly. The capillary tube is the sensing bulb at the outlet of the evaporator.

**Evaporator** - A tube core and fins are used in the evaporator similar to the condenser. Air is blown through the fins to allow the evaporator to cool and reduce the pressure.

**Blower and Motor** - Just as the condenser has a fan, the evaporator has a fan called the blower. The blower will draw air from the cab area and force the air over the evaporator coils and fins. This forced air will ensure continuous vaporizing of the R134a.

**Relays and Switches** - Both electronic and vacuum switches are used in the control and operations of the system.

---

**About Refrigerants**

**Chemical Stability:** The air conditioning system life and efficient operations depends upon the chemical stability of the refrigeration system. The refrigeration system is made of Refrigerant-R134a and Polyakylene Gycol (PAG) synthetic lubricant. It is very important that all materials contained within the refrigerant system be chemically compatible.

The only suitable compound for use with R134a is PAG. The total amount of PAG within the refrigerant system is approximately 18% of the total refrigerant in the system.

How much refrigerant is in the system? How much should be used when charging? You will need 1 oz. of PAG for each 7 feet of hose after the first 15 feet of hose. Roughly, a 40 foot motorhome will use 92 feet of refrigerant hose. Take 15 feet off the measurement and the result would be 77 feet. This 77 feet is then divided by 7 for total of 11. This represents the number of ounces of PAG oil needed for the A/C system (11 oz.).

Carrying the formula one step further, the 11 oz. equal approximately 18% of the entire system. The total will equate to approximately 61 oz. or 3.8 lbs. of R134a.

High pressure readings are another way to determine the amount of charge. The ambient temperature reading is measured one inch away from the condenser. The ambient temperature reading, plus 40° F, will equate to a value from the pressure table.

**EXAMPLE:**

**90° F. 1 inch from condenser + 40° F = 130° F ----- 198.90 PSIG -**

On fully charged system the expected pressure that should be seen on the HIGH-SIDE gauge will be around 200 PSIG.

**NOTE: All systems are charged at the factory with 4.0 lbs of R134A.**

TEMPERATURE	PSI GAUGE	TEMPERATURE	PSI GAUGE	TEMPERATURE	PSI GAUGE
16° F	15.69	60° F	57.47	112° F	151.30
18° F	17.04	65° F	64.10	114° F	156.10
20° F	18.43	70° F	71.19	116° F	161.10
22° F	19.73	75° F	78.75	118° F	166.10
24° F	21.35	80° F	86.80	120° F	171.30
26° F	22.88	85° F	95.40	122° F	176.60
28° F	24.47	90° F	104.40	124° F	182.00
30° F	26.10	91° F	106.30	126° F	187.50
32° F	27.79	92° F	108.20	128° F	193.10
34° F	29.52	93° F	110.20	130° F	198.90
36° F	31.32	94° F	112.10	135° F	213.70
38° F	33.17	95° F	114.10	140° F	229.40
40° F	35.07	100° F	124.30	145° F	245.80
42° F	37.03	102° F	128.50	150° F	263.00
44° F	39.05	104° F	132.90	155° F	281.00
45° F	40.09	106° F	137.30	160° F	300.10
50° F	45.48	108° F	141.90	165° F	320.00
55° F	51.27	110° F	146.50	170° F	340.80

psi gauge\_temp

**R-134a Refrigerant:** R-134a is classified non-explosive, non-flammable and non-corrosive.

There is hardly any odor and it is much heavier than air. R134a is ozone friendly; however, it is not technician friendly. Proper care in handling and adequate ventilation must be observed. Under normal atmospheric pressures and temperatures R134a will evaporate so quickly it will freeze anything it comes in contact with. The open container boiling point for R134a is minus 21.7° F. This low boiling point makes for an ideal refrigerant. The tremendous amount heat transfer which occurs when a liquid boils, or vapors condense, forms the basic principles of all A/C systems. The amount of heat required to raise or lower the temperature of one pound of water by 1° F equals one British Thermal Unit (BTU). The BTU is the standard measurement of an air conditioner system.

**Safety and Handling of 134A and Pag Oil:**

- When working with any refrigerant system wear eye protection and hand protection.
- Pag Oil irritates the skin. Flush with water immediately if in contact with any body part.
- Ensure any service work performed on the A/C system is in a well ventilated work area.
- Keep open flame away from service area. The discharge of a refrigerant gas near an open flame can produce a very poisonous gas.

**NOTE: O-rings used in a 134A system are Hydrogenated Nitrile Butadiene Rubber (HNBR). These are green in color and required for the 134A system.**



**A/C Heater:** The A/C system will also produce heat to warm the air in the dash area. Much like the refrigeration side of the system, a liquid will be used in the process. This liquid is the engine coolant. The coolant is passed from the radiator to an electronic water valve. The water valve, when open, will allow the coolant to flow through the heater core. The heater core is tubing and fins. Air is drawn into the system by a blower motor through the outside recirculation door opening. Air is blown through the A/C evaporator core and then through the heater core. When the temperature control is in the **WARM** position coolant flows through the heater core. When the temperature is in the **COOL** position coolant flow bypasses the heater core. In either position the air flow is felt at the discharge vents.

**Diagnosis of Electric Water Valve:** Theory of Operation: The thermostat is a potentiometer. The water valve, which controls the water flow to the heater core, is opened and closed by a stepper motor mounted on the water valve. A control module compares the output voltage from the potentiometer to the feedback for the stepper motor of the water valve. The control module then drives the motor to within one-half volt of the control potentiometer voltage.

**Functional Test:**

- Start and operate the engine until the water reaches normal operating temperature.
- Set the HVAC temperature control to the full hot position.
- The discharge air outlets should have hot air.
- Rotate the temperature control to full cold position.
- Allow 10 minutes for the temperature to stabilize.
- The discharge air outlets should have cold air.

**No Heat:**

- Check the blower and air mode operations. Repair prior to proceeding.
- Verify the engine is reaching normal operating temperature. (Check with engine manufacturer for proper procedure.)
- Check the inlet hose at the water valve. The hose has hot water at the valve inlet. The inlet water temperature should be the same as the engine water temp.
- With the temp control on full hot position, check the outlet hose of the water valve. The hose should be at engine water temperature.

**Vacuum Generator:** The vacuum generator is important to the operation of the dash heating and A/C systems. This provides the vacuum to open and close the vacuum switches. When the vacuum generator is operating it creates 15 inches of vacuum and is passed to a reservoir ball. Most dash heater and A/C systems will only require 10 inches of vacuum to operate the switches. The output from the reservoir is sent to the vent control knob. The control knob will then direct the vacuum operation to the appropriate vacuum switch to open or close vents and switches. The vacuum generator uses the air from the front air storage tank through a 1/4 inch red air line. Whenever the ignition is ON, and the A/C is operating, the vacuum generator will operate.

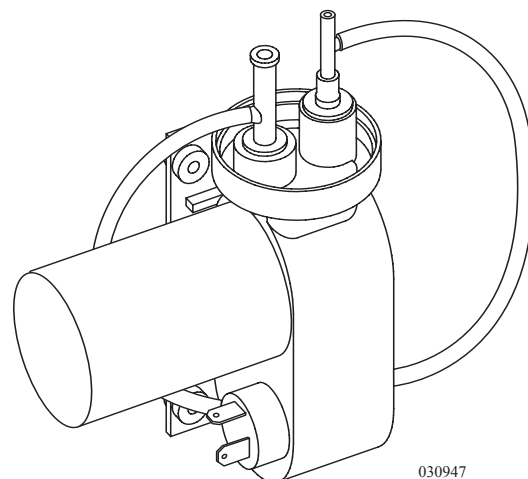

030947

---

---

## STEERING COLUMN - *Tilt & Telescope*

### **Tilt and Telescope Steering Wheel Control Lever: Located on the Steering Column.**

- To tilt the steering wheel pull the lever up. Tilt the steering wheel where desired. Releasing the lever will lock the steering wheel in the new position.
- To telescope the steering wheel push and hold the lever down. Push down or pull up on the steering wheel until the wheel is in place. Release the lever and the steering wheel will lock in the new position.

### **Turn Indicator and Headlight High/Low Dimmer Control Lever: Located on the Steering Column.**

- Pushing the lever forward will activate the right turn indicator circuits when the ignition is on.
- Pulling the lever down will activate the left turn indicator circuits when the ignition is on.
- Pulling the lever up will select high/low beam circuits when the headlights are ON.

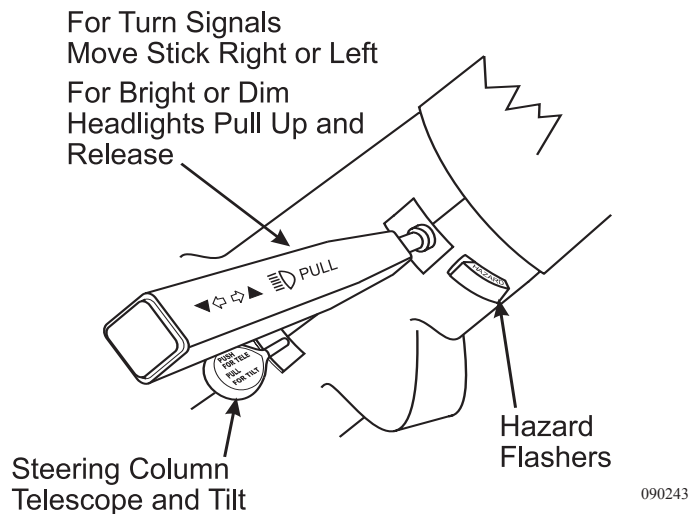

### **Hazard Flasher Button: Located on the Steering Column.**

- Pull out on flasher button to turn four way flasher on.
- Push button inward to shut off flasher.

## FUSE & CIRCUITS - Front Distribution Panel

The front electrical panel is located in the outside roadside front compartment and contains the fuses, self resetting manual reset supply circuit breakers, solenoid and relays.

The automotive fuses are located in the front electrical panel. The fuses are the standard plug-in type (ATM). When a fuse “BLOWS,” the wire in middle of the plastic case will be broken. A bad or blown fuse must be replaced with a fuse of the same rating and type. Using a fuse of a different type rating will defeat the circuit protection provided by the fuse, which could result in damage to the motorhome’s electrical system. If a fuse has been replaced and it “BLOWS” repeatedly, that may be an indication that a fault exists or an electronic component has failed. It is recommended that the motorhome be taken to a qualified RV technician before any future use to diagnose and repair the problem. Circuits are identified on the fuse label located on the inside of the electrical door. Remove 3 wing nuts, turn cover over to view.

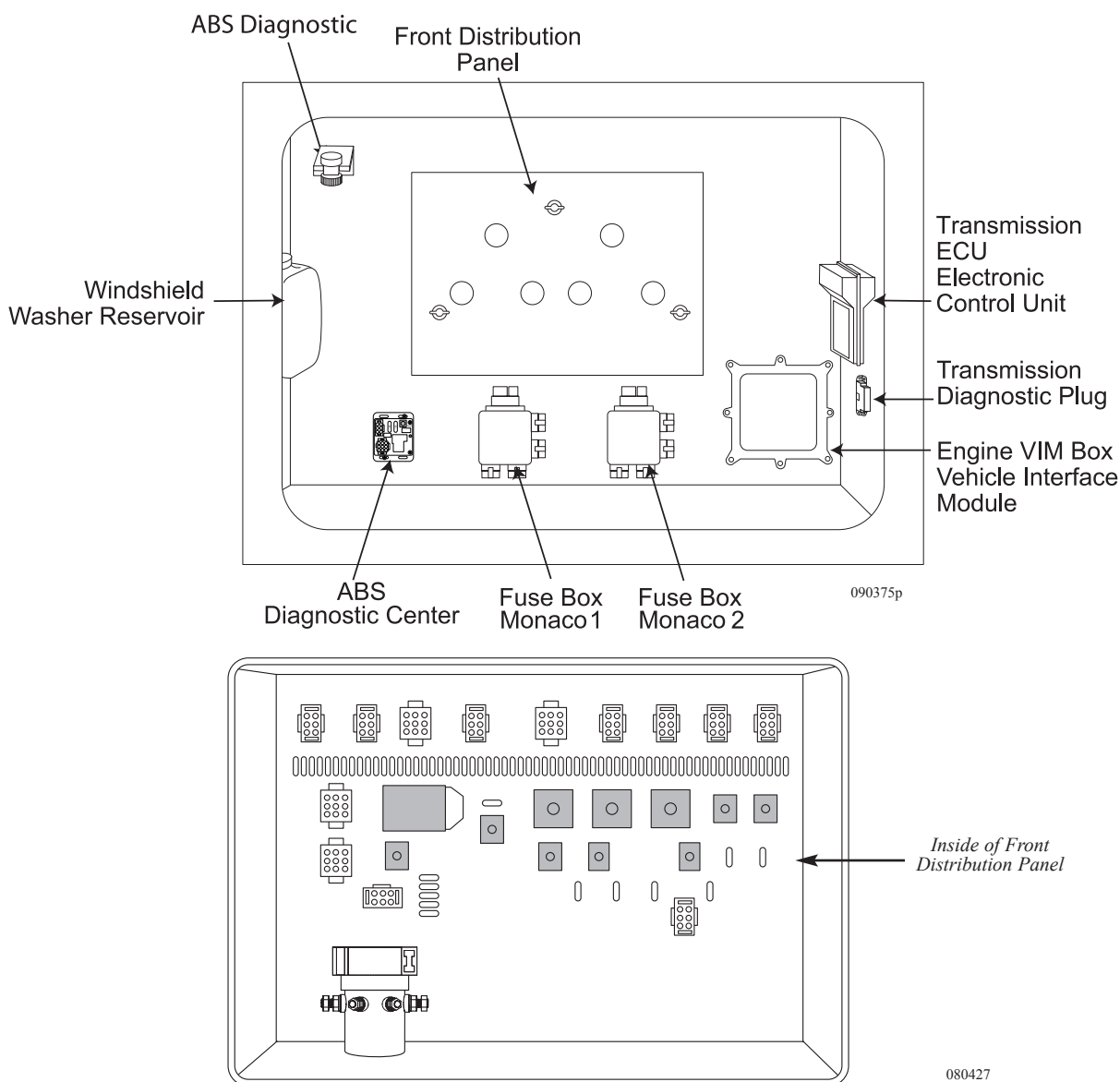

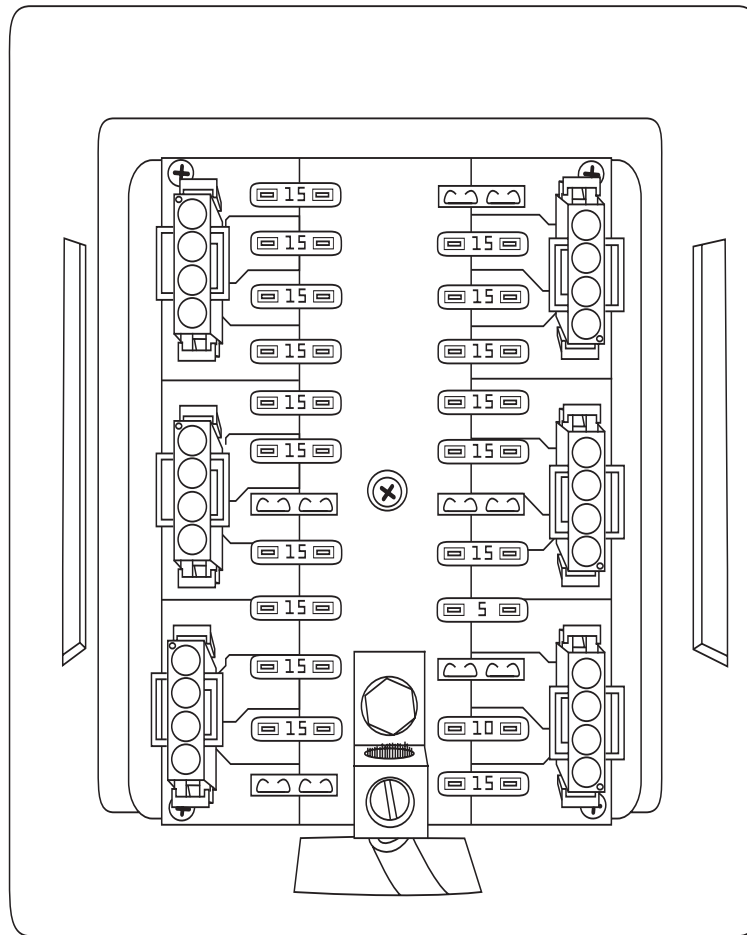
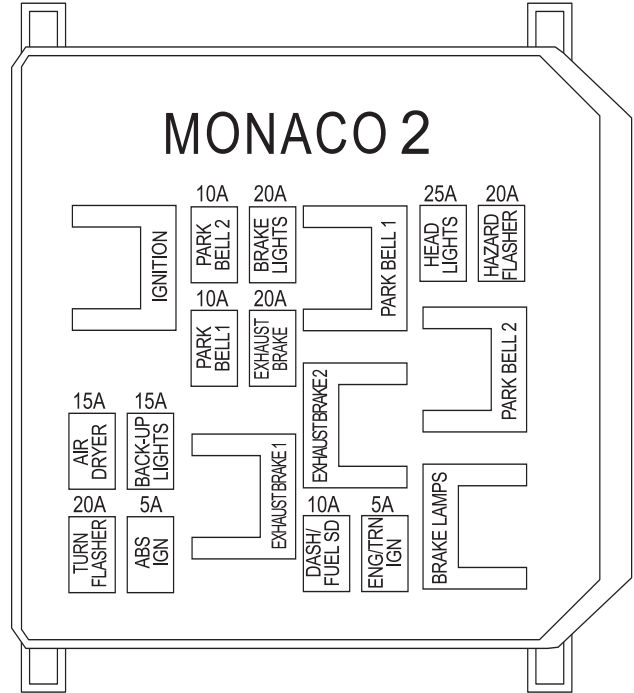
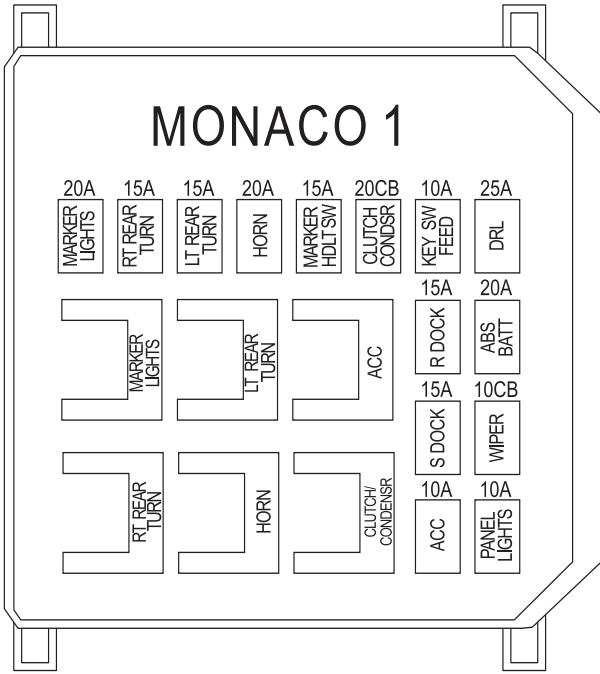

060284

Fuse label chart inside cover of distribution panel.

**ALTERNATOR**

The Leece-Neville alternator with integral rectifier, regulator and remote voltage sensor is designed for reliable output throughout the engine operating range. When traveling, keep an eye on the voltmeter in the dash area. Normal readings should be between 13 to 14.5 Volts. Voltage indications higher or lower indicate a problem with the charging system. If the alternator output drops below an acceptable level, a charge indication warning lamp will illuminate.

The alternator charges or maintains the chassis battery used to start the engine. The amount of charge to the batteries is dependent on the amount of time the engine is operated. Repeatedly starting the engine and driving the motorhome for a short distance, or short periods, may not be enough operating time to adequately recharge the battery used to start the engine.

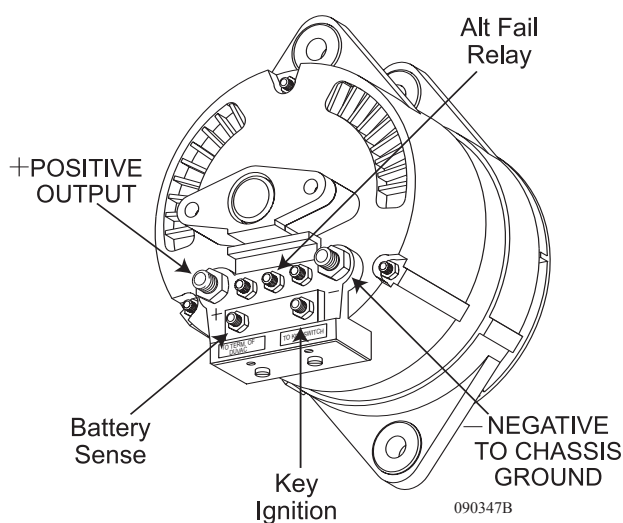
**Check Out Procedure**

The alternator also maintains a charge to the house batteries. The function of the alternator is an electrical system voltage maintainer, not a battery charger. When traveling, the alternator maintains electrical system voltage relative to any loads, such as headlights and windshield wipers. When a heavy load is placed on the alternator, such as trying to charge dead batteries, the operating temperature of the alternator increases dramatically. Excess operating temperature of the alternator for extended periods of operation can lead to premature failure of the alternator.

If the house batteries are in a low state of charge, or dead, before traveling it is recommended to charge the house batteries with the inverter/charger or an auxiliary battery charger.

**NOTE: Excessive loads applied to the inverter can actually drain both the chassis and house batteries during operation.**

**Specifications:**

- 160 Amp standard
- The integral rectifier system utilizes 12:50 Amp diodes mounted in multiple aluminum heat sinks for efficient heat dissipation during high-output operation.
- Aluminum housings
- Bi-directional fan
- Front bearing: 305 cartridge type
- Enclosed brush system
- Operation Ambient Temperature Range (-40° to 200° F.)
- Negative Ground Configuration
- Regulator Adjustment Range 13.6 to 15.4 Volts
- Batteries may start to gas at 14.3 Volts
- Max. Operating RPM 8000

**Alternator Testing Procedure:**

- Check all wiring for burnt or loose electrical connections. Repair as needed.
- Check all grounds and electrical connections to be sure they are clean and tight.
  - a. Alternator ground to chassis frame.
  - b. Motor block ground to chassis frame.
  - c. Chassis battery ground to chassis frame.

**NOTE: Inspect the alternator for damage. A broken fan blade can damage an alternator or make it out of balance.**

- Check belt, pulley and fan for wear. Replace as needed.
- Never attempt to disconnect the battery or battery wire from the alternator with the engine running. This can cause damage to the alternator or the regulator.
- The pulley for the alternator should be torqued to 80 foot pounds.
- Chassis battery voltage, with the engine OFF, should range from 12.2 to 12.7 Volts DC.
- Chassis battery voltage with the engine at idle, should range 13.5 to 14.2 Volts DC.
- The output of the alternator range is 13.6 to 15.4 Volts DC. Connect a voltmeter to the (B+) terminal of the alternator and chassis ground. Idle the engine up to 1200 RPM.
- Connect a clamp-on amp-meter, if available, to the positive battery cable to verify the battery state/rate of charge.

**NOTE: Remember the alternator is not a battery charger, but designed to maintain proper electrical system voltage. A battery with a low state of charge, or a dead battery, may overheat and damage the alternator.**







# Chassis Information

## Section 10

<b>CHASSIS - INTRODUCTION</b> .....	<b>315</b>
<b>AIR SUPPLY SYSTEM</b> .....	<b>316</b>
Air Governor.....	317
Air Storage Tanks .....	317
<b>AIR SYSTEM CHARGING(EXTERNAL)</b> .....	<b>318</b>
Air Coupler .....	318
<b>BRAKE SYSTEMS</b> .....	<b>319</b>
Air Brakes .....	319
Park & Emergency Brake Systems.....	320
Brake Adjustment/Slack Adjuster .....	320
Brake Systems - Back-Up .....	321
<b>EXHAUST BRAKE</b> .....	<b>321</b>
Maintenance.....	322
<b>AIR DRYER</b> .....	<b>323</b>
Desiccant Cartridge.....	325
Desiccant-Type Air Dryer .....	326
Air Dryer Cycle.....	326
Air Spring Inspections .....	326
<b>RIDE HEIGHT VALVES</b> .....	<b>327</b>
Adjusting.....	328
<b>ABS/ATC SYSTEM (ANTI-LOCK BRAKES)</b> .....	<b>329</b>
Automatic Traction Control System.....	332
<b>FRONT AXLE</b> .....	<b>333</b>
Alignment Specifications .....	334
Lubrication Maintenance Safety .....	336
Steering Components .....	337
Intermediate Steering Shaft.....	338
Drag Link .....	338
Center Link.....	339
Steering Spindle .....	339
Control Arm Bushings .....	339
Front Brakes .....	340
<b>DRIVE AXLE &amp; DRIVE SHAFT</b> .....	<b>340</b>
Lubrication Maintenance.....	342
U-Joint Angles, Phasing & Driveline Balance.....	344
<b>SHOCK ABSORBER</b> .....	<b>345</b>
<b>LEVELING SYSTEM</b> .....	<b>345</b>
Hydraulic Leveling RVA.....	345
Manual Leveling System.....	346
Retracting Leveling Jacks .....	346
Manual Override Retract Valves .....	347
<b>ENGINE - GENERAL INFORMATION</b> .....	<b>348</b>
<b>STARTING PROCEDURE</b> .....	<b>350</b>
Normal Starting.....	350
Cold Weather Starting.....	350
<b>OIL RECOMMENDATIONS</b> .....	<b>351</b>
Routine Oil Maintenance .....	353
Cold Weather Engine Operation.....	353
<b>ENGINE SHUTDOWN</b> .....	<b>354</b>
Extended Engine Shutdown.....	354
<b>TRANSMISSION</b> .....	<b>355</b>
Shift Selector.....	355
Transmission Check Light.....	357
Periodic Inspections .....	358
<b>TRANSMISSION LUBRICATING FLUID</b> .....	<b>360</b>
Fluid Levels - Cold Check .....	360
<b>COOLANT SYSTEM</b> .....	<b>361</b>
Coolant .....	363
Coolant Additive (SCA) .....	364
Maintenance Procedures .....	364
<b>CHARGE AIR COOLER</b> .....	<b>366</b>
<b>FUEL SYSTEM</b> .....	<b>367</b>
Fuel Sender .....	368
Fuel Filters.....	370
Fuel Line & Hoses .....	370
<b>HYDRAULIC SYSTEM</b> .....	<b>371</b>
Hydraulic Reservoir .....	371
Hydraulic Pump.....	371
Hydraulic Filter .....	372
<b>AIR INTAKE &amp; CHARGE AIR SYSTEM</b> .....	<b>372</b>
Air Filter Minder.....	373
Changing Air Filter .....	373
<b>LUBRICATION CHARTS</b> .....	<b>374</b>
<b>SPECIFICATIONS - DIMENSIONS CHART</b> .....	<b>376</b>
<b>CHART - FILTER &amp; BELTS</b> .....	<b>377</b>
<b>BATTERY SPECIFICATION CHART</b> .....	<b>378</b>
<b>METRIC/U.S. CONVERSION CHART</b> .....	<b>379</b>
<b>MAINTENANCE RECORD</b> .....	<b>380</b>



## CHASSIS - INTRODUCTION

This section contains knowledge and information on various components of the motorhome chassis. Following the guidelines and procedures will help you to understand and operate your motorhome. Complete instructions for engine and transmission are located in their respective operators manual included in the Owner's Information File box.

**WARNING: When welding is involved for motorhome repair or modification, only qualified, experienced technicians should weld on the chassis. Improper welding procedures and materials may weaken the assembly or result in damage that is not obvious and may not cause an immediate problem or failure. Unauthorized modifications or repairs to the chassis could result in a forfeiture of warranty coverage.**

**DANGER: Due to the sensitive nature of the electronics on the chassis, the following precautions are required to protect electrical components in the motorhome chassis:**

1. Disconnect the (+) positive and (-) negative battery connection.
2. Cover electronic control components and wiring to protect from hot sparks.
3. Disconnect the terminal plugs from the engine Electronic Control Unit, located on the passenger side of the engine block.
4. Disconnect all the plugs from the transmission Electronic Control Unit, located in the storage bay between the frame rails.
5. Disconnect the wiring from the alternator.
6. Do not connect welding cables to electronic control components.
7. Attach the welding ground cable no more than two feet from the part to be welded.

The Roadmaster chassis design provides exceptional balance, handling and braking characteristics. The Roadmaster chassis is an engine and frame unit featuring an all steel frame design, providing greater structural integrity and uniform stress distribution. Incorporated in the Roadmaster chassis is the air suspension system using eight air bags and gas shock absorbers. Design and set up provides the smoothest ride, best handling and trouble free service while delivering excellent drivability. The chassis has a three-point hydraulic leveling system and offers unsurpassed ease of maintenance and service.

The towing system rating incorporated in the construction of the frame is 10,000 lbs. towing and 1,000 lbs. tongue weight.

The Roadmaster's exclusive stacked-rail chassis with air suspension consists of front and rear axles, with trailing links. A panhard bar on each axle controls side motion. Each axle mounts to the trailing links that are connected to the chassis. Stacked rail design of the main chassis offers increased bay storage space. Suspension control arms attach to the frame through bushings, which require no lubrication. The preset suspension ride height automatically maintains proper suspension height throughout the load range.



*Located on frame behind right front tire.*

100168c

## AIR SUPPLY SYSTEM

The air compressing system on the motorhome is comprised of several items: air compressor, air governor, air dryer, a front air tank and a rear air tank. The compressed air system operates several items, some of which include brakes, suspension, air horns, air gauge. The air system is charged by a gear driven air compressor mounted on the engine. As engine speed increases, compressed air output increases. When air is compressed, heat is generated. Heat dissipates as air is discharged from the compressor. Moisture condenses in the compressed air as it cools. The moisture laden air then enters an air dryer where the air is filtered. The filtered air charges the front air tank. The front air tank is divided in two halves: a wet side and a dry side. The compressed air enters the wet side before entering the dry side. A discharge line from the dry side of the front air tank charges the rear air tank. Discharge lines use inline check valves to prevent back flow of compressed air.

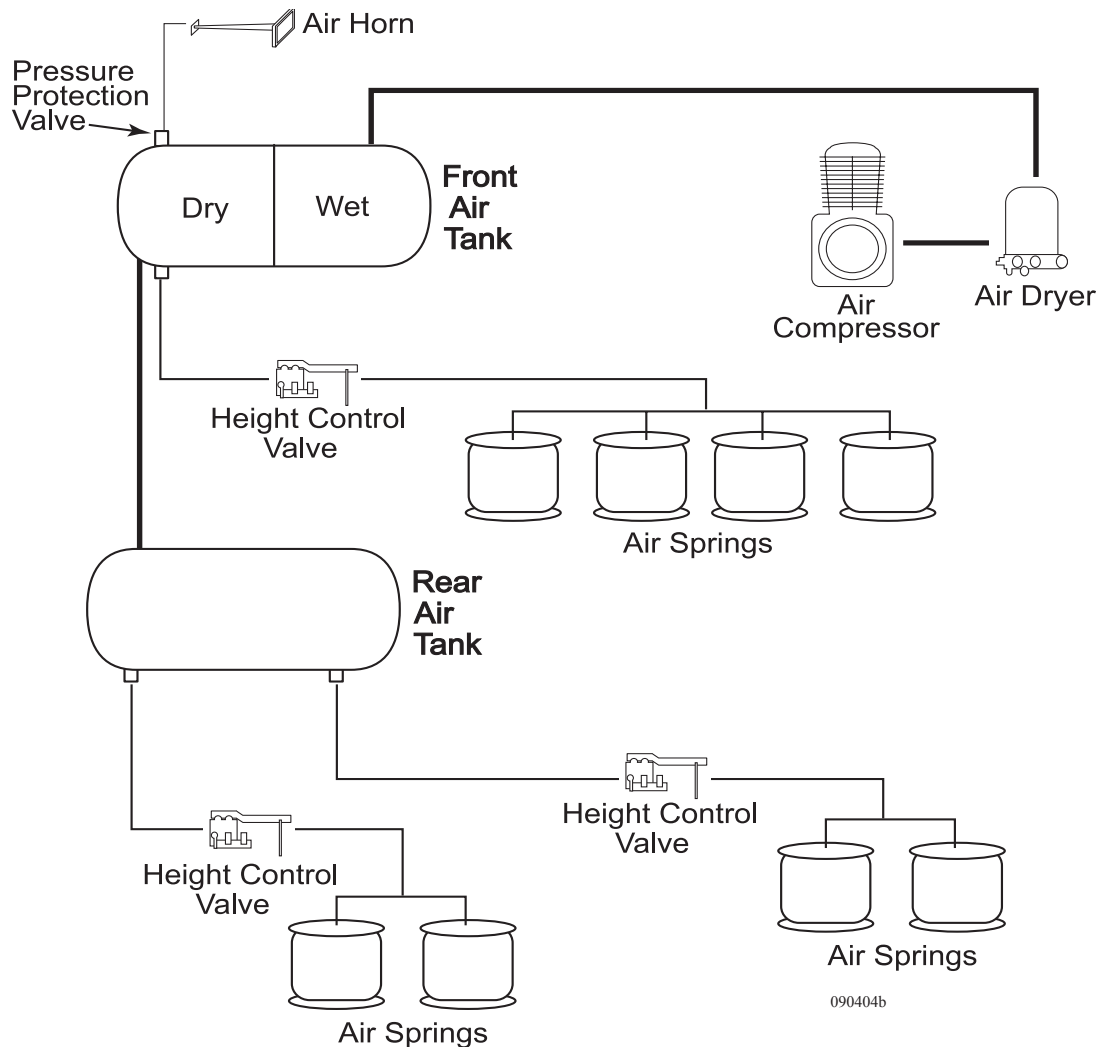

The pneumatically operated items are divided into two categories: brakes and accessory air. Brakes have full use of supplied air pressure. Accessory air items, such as air horns, receive air through pressure protection valves (PPV). The PPV will not allow compressed air flow until about 60 psi. In the event of an air system problem, the pressure protection valve will leave a reserve air charge for braking. Pressure protection valves are installed for safety.

The air governor, located in the engine compartment, regulates the air compressor to cut-in and cut-out, keeping the air system in the specified operating range of 105 to 120 psi, then sends an air "purge" signal to the Air Dryer.

Cut-in pressure of about 105 psi is factory preset from the governor manufacturer and is not adjustable. Cut-out pressure is calibrated to 120 psi. When cut-out pressure is reached, the governor will send an air purge signal to the Air Dryer. This opens the purge port of the Air Dryer, expelling moisture. The purge action of the Air Dryer is identified by the short release of air at the rear of the motorhome.

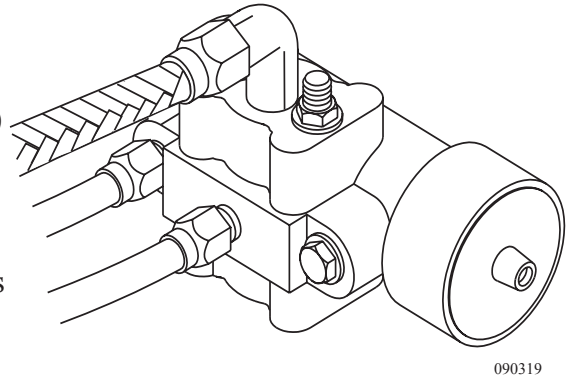

## **Air Storage Tanks**

The front and rear air tanks should be manually drained once a month, or more, depending on operating conditions where humidity is high.

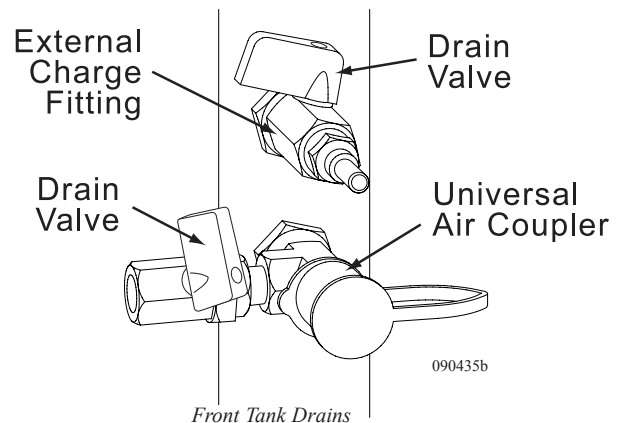
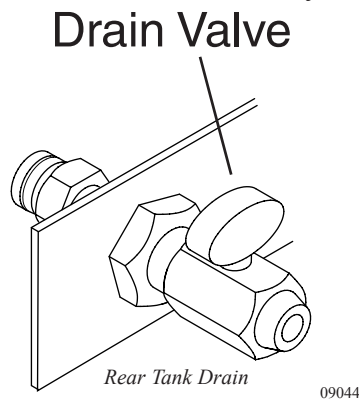

### **Air Drains:**

Air system tank drains are located in the generator compartment and in the rear engine compartment. The air tanks should be drained at least once a month or more often in areas of high humidity and where temperature fluctuates 40° F. or more daily.

### **To Drain the Tanks:**

- Slowly open the drain valves as moisture will be expelled under pressure. After all moisture and air is purged from the tanks, the valves should remain open an additional five minutes to allow any moisture remaining a chance to drain.
- Close valves and start engine. Check valves for leaks.

**WARNING: Wear safety glasses to prevent eye injury from expelled moisture. Open drain valves slowly as moisture will be expelled under high-pressure.**

**NOTE: Both air tanks have a pressure relief valve set to release at about 130 psi.**

## AIR SYSTEM CHARGING (EXTERNAL)

The air system on the motorhome can be charged from an external air supply source. Located in the front generator compartment is a type C automotive male fitting. Caution should be used when charging the air system from this fitting. The air supplied from an external source may contain moisture. Compressed air introduced into the air system from this fitting is not filtered by the air dryer. The auxiliary air charge fitting will charge the front and rear air tanks. A shut-off valve is installed to prevent air from escaping.

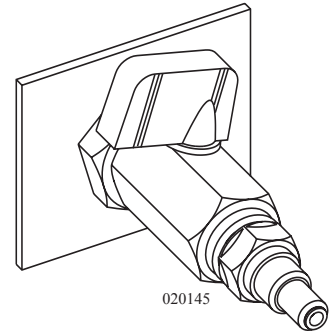

**CAUTION:** The external air supply source should be regulated to charge the air system on the motorhome no higher than 120 psi. Damage to the air system or pneumatically operated items may occur.

### Air Coupler

Provided for convenience is a remote air supply coupler located in the generator compartment. This female fitting will accept type C automotive connectors. This auxiliary air fitting may be used to inflate tires, air mattresses or other pneumatic items. This fitting is not designed to charge the air system on the motorhome. The air supply for the auxiliary air fitting is charged from the front air tank through a pressure protection valve.

#### To use this feature:

- Slide the locking collar back. Using a firm grip, fully insert the air fitting into the auxiliary air supply. Release the locking collar to retain the air fitting after the fitting is properly inserted.

#### To remove fitting:

- Firmly grip the air hose near the fitting to prevent recoil.
- Slide the locking collar back to release fitting.

**NOTE:** There are small air pressure restrictions in the pressure protection valve and tire stem valve. Due to this restriction, the maximum amount of tire pressure achieved when the system is used to fill a tire is about 95-105 psi with air system on the motorhome charged to 120 psi. Maximum outlet air pressure is achieved when the air system completes the fill cycle indicated by the purge cycle of the air dryer.

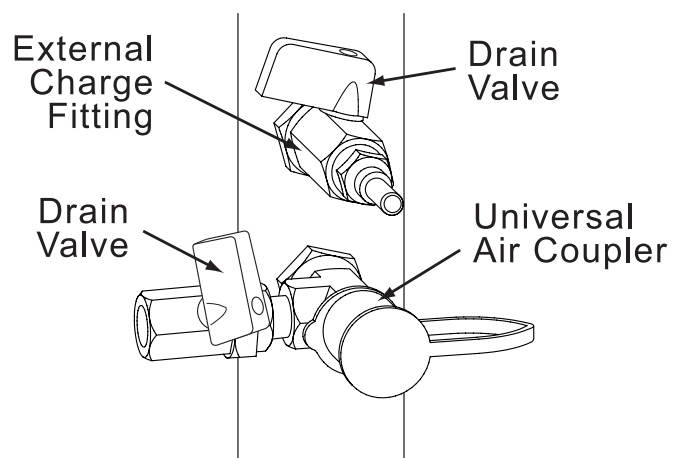

090435b

---

**BRAKE SYSTEMS - Air Brakes**

The motorhome is equipped with air brakes using the same efficient system as over the road trucks. Proper maintenance and lubrication is the key to keeping the brake system in proper working order. The brake system on the motorhome is designed to accommodate the weight of the vehicle and towing loads. This system differs from a conventional automotive hydraulic braking system and should be treated differently.

When operating a vehicle equipped with air brakes consideration needs to be given to stopping distances and air system pressures. The heavier the vehicle, the greater the kinetic energy. The motorhome requires longer stopping distances. Each brake application uses air from the air system. Give attention to the air gauge as well as the surroundings. Engine speed is directly proportional to how fast the air system is replenished. Prepare for downhill grades. Grades are generally posted in percentages. It may be necessary to select a lower gear. Make use of the engine exhaust brake. When making brake applications use individual short applications down long hills rather than “riding” the brakes. This will extend the life of the brake lining. Avoid overheating the brakes. Hot brakes have less stopping power. When maneuvering the motorhome around in small areas, or backing into spaces, several individual brake applications might be made. Watch the air gauge. Plan ahead when parking to make it easier on yourself. When preparing to back into a space swing the motorhome so it is aligned with the parking slot before backing up.

The air braking system on the motorhome is equipped with several safety features unlike that of automotive hydraulic braking systems. One safety feature is a low air pressure warning system. Should a low air condition arise while the vehicle is under operation a warning buzzer will sound and a dash warning light will illuminate alerting the operator of the situation. This warning occurs at about 60 to 65 psi (pounds per square inch).

A simple mechanical explanation of what occurs when a brake application is made as follows: The air system supplies air to the foot brake, this is called a treadle valve. Pushing down on the treadle valve supplies an air charge signal to a brake chamber. This sealed chamber consists of a spring and air bladder. The air charge signal pushes on the bladder which extends a threaded rod connected to the automatic slack adjuster. The slack adjuster rotates the S-cam expanding the shoes against the drum. Air disc brakes follow much the same principle, with the exception of the S-cams.



## **Park & Emergency Brake Systems**

The park and emergency brake systems combined apply to the rear drive axle only, and are called spring brakes. When the park brake is applied, air is released from the rear brake chambers, allowing the large spring in each rear brake chamber to manually push the brake shoes against the drum. The air system must be charged above 35 psi for the park brake to remain released. Pushing down on the park brake handle charges the rear brake chambers with air pressure, overriding the emergency brake springs and releasing the brakes. In the event of air loss while the vehicle is under operation, the park brake will automatically apply (this occurs at about 30 psi) acting as an automatic emergency brake system.

When preparing to depart, allow the air system to achieve full air pressure, as indicated by the dash air gauge needles. Listen for the air dryer to purge, indicating full air pressure has been obtained and the air dryer is functioning. Look and listen for abnormalities. Abnormal air pressure readings by either needle of the air gauge should alert the operator. Have the air system checked to avoid an untimely failure.

Should a failure occur in the air system, preventing the air pressure from building, it may become necessary to “cage” the spring brakes. This is an emergency procedure only. Caging the rear air brake chambers manually overrides the spring brakes and allows the vehicle to move. This procedure does not affect normal service braking. (See Section 2 for details.)

**NOTE: When the park brake is released the Park illumination lamp will remain lit until air system pressure is above 65 psi.**

**WARNING: When parked, if the air tank is not depleted there is the possibility of an accidental release of the parking brake. Traveling with small children and/or pets may require a small block to be fabricated to prevent accidental release. The block should be placed under the knob on the dash panel. A wooden clothes pin, clasped at the base of the shaft, will work.**

---

## **Brake Adjustment/Slack Adjuster**

The motorhome is equipped with automatic slack adjusters. As brake lining wears, the slack adjusters will automatically ratchet on the return stroke as needed. This ratchet action will keep the brake lining at proper adjustment. Brake adjustment should not be necessary. Indications of a vehicle needing possible brake adjustment may be noticed by the park brake not holding on a hill, or gradual loss of braking power. Automatic slack adjusters and the connecting S-camshaft require periodic lubrication.

**NOTE: Replacement parts should be of the same original equipment size and type. Mixing brake components may result in unequal braking action. Brake adjustments are part of normal maintenance of the motorhome. Brake adjustments are not covered by the manufacturer warranty.**

**WARNING: Brake lining may contain asbestos material and should only be serviced by qualified service technicians who are trained in the appropriate precautionary procedures. If any loss of braking effectiveness or abnormal braking indications are noticed, the brakes and slack adjusters should be inspected by a qualified brake technician.**



## Brake Systems - Back-up

The motorhome air braking system is equipped with back-up safety systems and warning alarms in case of an air system failure. Refinements to air braking systems have been instituted with safety as top priority.

One back up safety is the air system separation of the front and rear brakes, implemented by using two air tanks. One tank is located in the front and the other is located in the rear. This separation allows the front air tank to operate the front brakes; the rear tank operates the rear drive axle brakes. This tank division gives reassurance in case one tank experiences a failure of an accessory air item allowing the compressed air to escape.

In another situation, whereby all compressed air has escaped from the rear air tank, a pneumatic back-up safety valve is installed. This is the safety inversion valve. The inversion valve senses the absence of rear air tank pressure. In this case the inversion valve will allow the operator to make a modulated spring brake application, made in conjunction with the emergency spring brake relay valve. The inversion valve allows the front air tank pressure to recharge the rear brake chambers after the modulated spring brake application has been made. This back-up system implements use of all the brakes, allowing the operator to bring the vehicle to a safe stop. In case of all compressed air charge escaping from the front air tank, the operator will still have full use of the rear brakes.

## EXHAUST BRAKE

The Pac Brake exhaust retard system is an auxiliary braking device that is attached directly to the engine turbocharger. The exhaust brake operates by using a dash switch. The dash mounted switch will operate the exhaust brake when dash switch is **ON** and throttle is **RELEASED**.

When the exhaust brake is activated, a flapper inside the exhaust brake moves and restricts the flow of exhaust gas, to increase exhaust pressure within the engine. Increased exhaust back pressure quickly slows engine speed, resulting in a powerful engine braking action. When the exhaust brake is activated, the amount of engine braking power developed is related to engine speed (RPM). When an exhaust brake application is made, the engine braking affect increases with higher engine RPM. The exhaust brake is wired to the electronically controlled transmission. When the exhaust brake is activated going down a hill, it will help control road speed, or sufficiently slow road speed, until the Allison Transmission can automatically downshift to the next lower gear. Downshifting automatically occurs from high gear down to second gear. Certain road conditions and engine speeds may require the transmission be manually shifted down in order to generate adequate engine RPM and increase the engine brake effect.

**NOTE: The brake lights will illuminate while the PAC Brake is applied.**

**NOTE: Cruise Control will not engage with the exhaust brake switch in the ON position.**

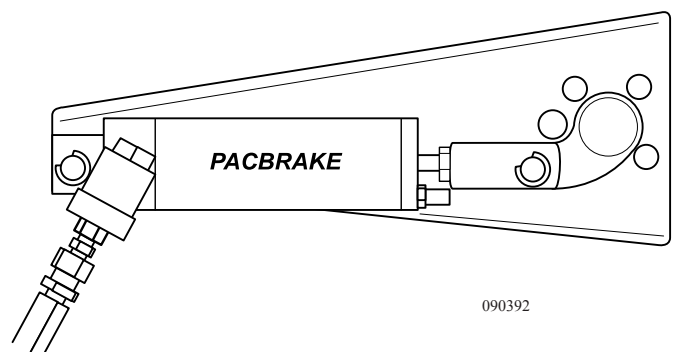

090392

## Maintenance

The exhaust brake system, used routinely at normal exhaust operating temperatures, is virtually maintenance free. There are contributing causes which can result in failures with the exhaust brake, including moisture, dirt, carbon, and improper usage.

Starting the engine and idling for short periods of time is not recommended, because moisture is created within the engine and exhaust system during cold startups. When normal operating temperatures are not obtained, moisture may get trapped in the valve housing to result in rust and insufficient operation of the exhaust brake.

To help prevent exhaust brake freeze-up, caused by periods of non-use, it is recommended to use silicone spray at the points shown. Apply liberal amounts of silicone spray to the moving joints whenever the motorhome is parked for storage. Use a pair of pliers to manually operate the valve several times to work the lubricant into moving parts.

**NOTE: Do not use petroleum-based lubricants as these will burn off and possibly create a fire hazard.**

Some problems that may be encountered with the exhaust brake include, but are not limited to, will not activate or deactivate, intermittent on/off operations or actuates with the switch off, commonly related to electrical symptoms. Other problems such as slow operation, delay in operations, and limited performance are mechanical symptoms. Refer these problems to the dealer for diagnosis.

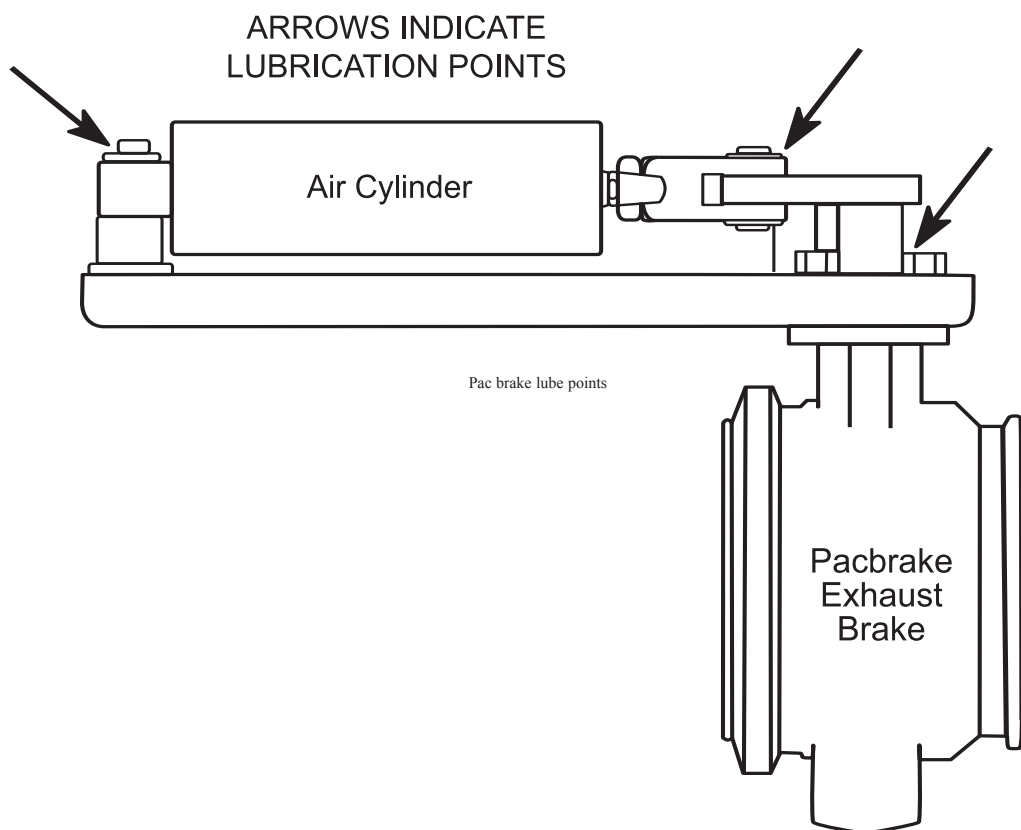

The air dryer is located on the frame behind the roadside air conditioner cooler. The air dryer removes moisture from the compressed air system. This is important because if air contains moisture it can freeze and prevent operation of brakes or other pneumatic operated items.

The air dryer has three functions: cooling, filtering and drying the air going through the motorhome's air system. If an excessive amount of water is present when performing the monthly air tank drain service, it may be an indication that the filter for the air dryer needs to be changed.

**Operation:** During system pressure build-up, compressed air passes into the air dryer where the filter system removes contaminants and passes the air into the drying stage. When the compressor unloads, water is expelled and the dry air flows back through the dryer, drying the desiccant for the next cycle. Initially, moisture condenses in the base of the dryer. Moisture-laden air passes through the desiccant bed in the air dryer cartridge and is dried.

- The compressor intakes water vapor with the air. The water vapor condenses as it cools.
- The air dryer prevents water accumulation in air lines that could damage seals and valves and wash away lubricants.
- The air dryer also prevents water in the air lines that can freeze and damage air system components.

**Air Dryer Components:**

- 1. Purge Valve:** A valve located on the bottom of the air dryer base that remains open during a compressor unload cycle. The purge valve allows collected moisture, condensation and contamination to be expelled from the air dryer during the purge cycle.
- 2. Pressure Relief Valve:** Protects the air dryer from over-pressurization.
- 3. Regeneration Valve:** Controls regeneration of the desiccant. The regeneration valve allows air from the supply and secondary tanks to bypass the outlet check valve. The air expands and back flushes moisture off the desiccant through the dryer's purge valve.
- 4. Heater Power Harness:** Twelve-inch cable with Metri-Pack plug provides electrical connection to air dryer heating unit.

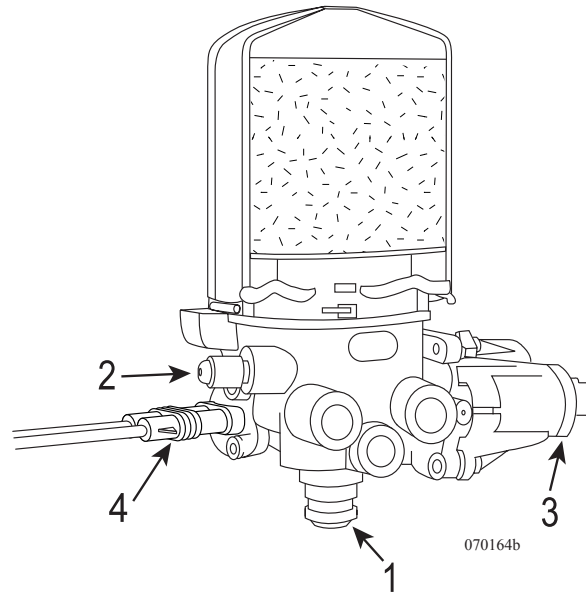

In extreme cold, verify that the air dryer heater is in good working order. The heater in the air dryer is a 100-watt heater controlled by ignition power and turned off when the ignition is switched off. The heater turns on below 45° F and off when the air dryer temperature is above 86° F. The fuse is located in the front electric bay, roadside.

**WARNING: Remove all pressure from the air system before disconnecting any component, including the desiccant cartridge. Pressurized air can cause serious personal injury.**

**Desiccant Cartridge**

1. The replacement kit contains one cartridge and one O-ring.
2. Place wheel chocks firmly against wheel before removing cartridge.
3. Remove all air pressure from the air system.
4. Loosen and remove the old cartridge. Use a strap wrench, if necessary.
5. Remove and discard the O-ring from the dryer base.
6. Inspect and clean the seal seat. Repair any minor damage.



070165

**NOTE:** If the seats are damaged so badly that a tight seal cannot be maintained, replace the air dryer.

7. Lubricate the O-Ring on the stem with a thin layer of grease.
8. Lubricate the cartridge seal with a thin layer of grease.
9. Thread the replacement cartridge onto the base until the seal touches the base. Tighten the cartridge ONE additional turn. **DO NOT OVERTIGHTEN.**

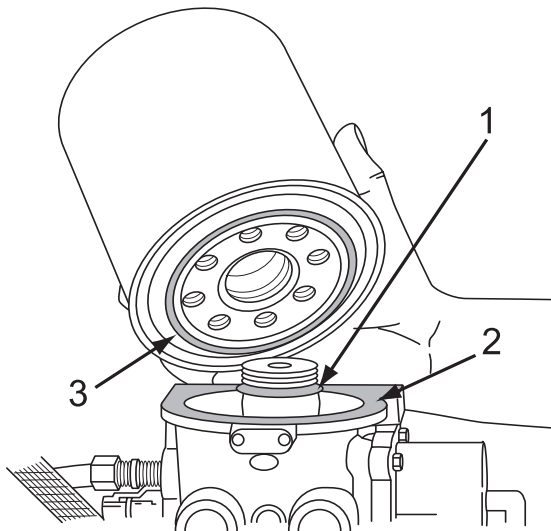

1. O-Ring
2. Seal Seat
3. Seal

080223

REPLACEMENT REQUIREMENTS		
Components	When to replace	Why
Desiccant Cartridge	Every two to three years. When compressor is replaced. Water in supply tank.	Preventive maintenance. Contaminated cartridge. Saturated or contaminated cartridge, high duty cycle (wrong application of air dryer).

## **Desiccant-Type - Air Dryer**

1. Warm, humid air from the compressor condenses into either water or water vapor before entering the air dryer.
2. A desiccant-type air dryer protects the motorhome air brake system by drying moisture-laden air before it passes through the air reservoirs and into the brake system.
3. Water collects in the base of the dryer when warm air condenses the water before it enters the dryer, or inside of the dryer before the water reaches the desiccant.
4. The desiccant material then removes additional water vapor, further drying the air.
5. During regeneration phase, the regeneration valve and pressure-controlled check valve remove water from the desiccant bed with a backflow of dried, expanded system air.

---

## **Air Dryer Cycle**

The governor turns the compressor on when the supply tank pressure drops below cut-in pressure. Compressed air passes into the air dryer at the inlet port:

1. Moisture-laden air and contaminants pass through the desiccant.
2. Moisture is retained by the desiccant. Moisture also collects in the base of the dryer.
3. When the compressor unloads the purge valve opens. The governor turns the compressor off when the system reaches cutout pressure (about 120 psi).
4. The dryer purges and expels water collected in the dryer base.
5. When the regeneration valve opens, the dry system air flows back through the dryer. A small charge of air from the front tank back flows through the filter. The backflow dries the desiccant, preparing it for the next cycle.

---

## **Air Spring Inspection**

Listed below are items that can be checked when the motorhome is in for periodic maintenance.

**NOTE:** Never attempt to service the air suspension on a motorhome with the air bags inflated.

- **Inspect** the OD (outside diameter) of the air springs. Check for signs of irregular wear or heat cracking.
- **Inspect** the air lines to make sure contact does not exist between the air line and the OD of the air springs. Air lines can rub a hole in an air spring very quickly.
- Check to see that there is sufficient clearance around the complete circumference of the air spring while at maximum diameter.
- **Inspect** the OD of piston for buildup of foreign materials. On a reversible sleeve style air spring, the piston is the bottom component of the air spring.
- The correct ride height should be maintained. All motorhomes with air springs have a specified ride height established by the manufacturer.

- The leveling valves (or height control valves) play a large part in ensuring that the total air spring system works as required. Clean, **inspect** and replace if necessary.
- Make sure to check shock absorbers for leaking hydraulic oil and worn or broken end connectors. If a broken shock is found, replace it immediately. The shock absorber will normally limit the rebound of an air spring and keep it from over extending.
- Check the tightness of all mounting hardware (nuts and bolts). If loose, tighten. Do not over-tighten.

**Cleaning:** The approved cleaning method is to use soap and water, methyl alcohol, ethyl alcohol and isopropyl alcohol. Unapproved cleaning methods include all organic solvents, open flames, abrasives and direct pressurized steam cleaning.

## RIDE HEIGHT VALVES

Height control valves (HCV) inflate or deflate the air springs maintaining the proper suspension height throughout the load range. Two valves are used at the drive axle. These valves control rear suspension height and left or right tilt of the motorhome. One valve controls the front suspension height. The height control valves mount to the main frame of the motorhome above the axles with a linkage rod connecting the valve to the axle.

The actuating components inside the valves are oil damped to reduce valve reaction to momentary suspension bounce and rebound. When a constant suspension change occurs, such as a load change or weight transfer through a sustained corner, the valve reacts, adding or purging air from the air springs as needed.

The air springs mount between the main frame rails and the trailing links. The air spring must maintain a specified distance between the mounting plates. Other than specified distance between the plates not only compromises ride quality and handling, but adversely affects shock absorber travel, drive shaft angle and various other running gear components.

Should it become necessary to check the suspension ride height, start with the motorhome on a flat level surface. The air system must be fully charged with the suspension normalized at ride height. Specified distances may vary plus or minus ¼". Ride height values require special equipment for adjustment. Adjustment should be performed by a qualified technician.

**NOTE: Drive shaft angle is affected by the suspension ride height. Improper drive shaft angle can damage suspension or shorten the life of universal joints. Shock absorbers and air springs are in travel centers at proper ride height.**

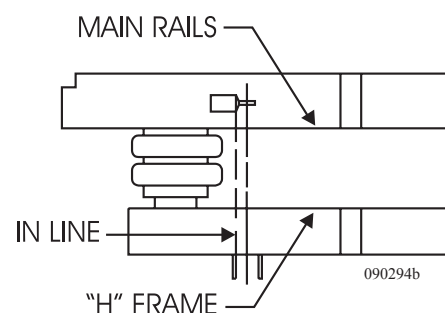

## Adjusting

### To adjust the suspension ride height begin with:

- The motorhome on flat level surface.
- Air system fully charged.
- Suspension at normal ride height.
- Air Level System in travel mode.

### Start by checking the distance in the front.

1. Measure the distance between the lower air bag mounting plate and the upper air bag mounting plate of the air springs.
2. If the measurement is off, loosen the adjusting lock nut at the eccentric slot on the valve.
3. Move the plastic arm up to raise suspension height, this will inflate the front air springs. Move the plastic arm down to lower suspension height, this will deflate the air springs. Make adjustments in small increments.
4. After obtaining the specified distance, insert a 1/8" or 7/64" inch twist drill bit into the plastic arm and valve body. This will center the travel of internal piston. Tighten adjusting lock nut between 60-80 in/lbs.
5. Check adjustments made by using the Air Dump switch to deflate air springs. Start the engine and allow the air system to become fully charged. Allow the suspension to reach a neutral setting.
6. Re-check the suspension height measurement. Follow the same procedure for each rear control valve.
7. Re-check the front suspension height after adjusting the rear height control valves.

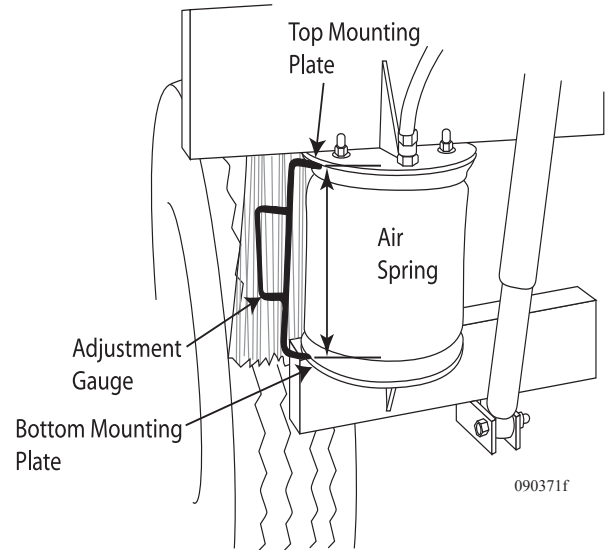

Adjustment Gauge Measurement: Front = 8-5/16"  
Rear = 8-13/16"

**NOTE: Do not modify length of the linkage rods. Make any necessary adjustments using eccentric slot on the ride height control valve.**

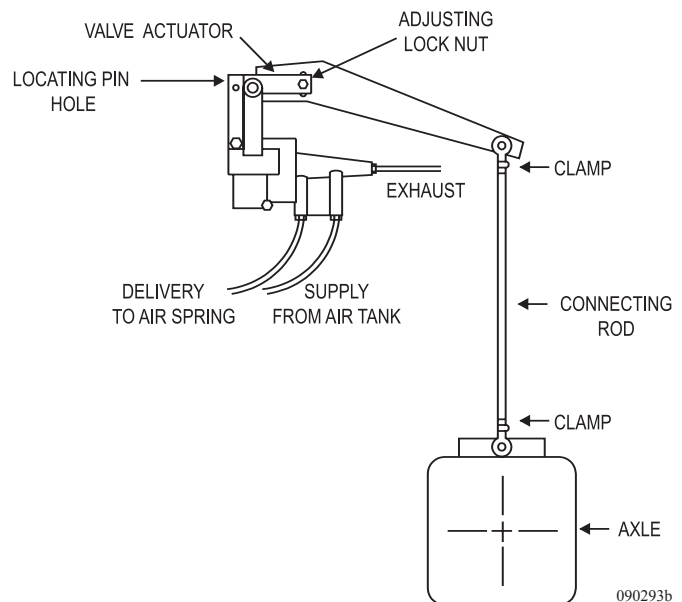



## ABS/ATC SYSTEM (Anti-lock Brakes)

The motorhome is equipped with an anti-lock braking system (ABS) and automatic traction control system (ATC). The ABS system monitors wheel rotation speeds by using a 100-tooth magnetic tone ring mounted to the hub. Revolving with the wheel, the magnetic tone ring is polarized giving positive and negative pulsations. A stationary sensor is mounted adjacent to the tone ring monitoring the magnetic pulses. The pulses are monitored by the ABS electronic control unit (ECU).

The ECU monitors all available wheel sensors at the rate of 100 times per second. The ECU controls Pressure Modulator Valves. Pressure Modulator Valves have two electric over air solenoids, a hold solenoid and a release solenoid. The modulator valves are open under normal braking, allowing a straight through air signal from the treadle valve to the brake chamber. Should a wheel lose traction under a braking application, the ECU will energize the hold solenoid of the Pressure Modulator Valve to interrupt the air signal from the treadle valve to the brake chamber. The release solenoid vents the existing air signal, at the brake chamber to the atmosphere, allowing the skidding tire to regain traction. Skidding tires have less tractive efficiency. It is possible, under certain conditions, to have the wheel(s) skid with a normal functioning ABS system.

The ABS itself does not apply additional braking power. The purpose of the ABS is limiting brake torque to prevent wheel locking that results in the loss of lateral stability, and increased stopping distances. Cautious driving practices and maintaining adequate safe distances when following vehicles is the key to safe vehicle operation.

**WARNING: The ABS/ATC system is designed to increase tire to road surface traction. The system cannot overcome naturally occurring laws of physics. The ABS/ATC system combined with safe driving practices reduce the possibility of wheel skid and loss of lateral stability.**

### ABS Component Function:

- Speed sensors and tone rings on each wheel monitor wheel rotation.
- Each speed sensor communicates wheel rotation pulses to the Electronic Control Unit.
- ECU receives the speed sensor inputs, interprets the signal pulses, calculates speed and acceleration rates of each wheel.
- Based on the speed sensor input, the ECU detects impending wheel lock and operates the ABS Modulator Valves required for proper control. The Modulator Valves can be operated in the air, release or hold modes to regulate air pressure to the brake chambers.
- The braking force is applied at a level which minimizes the stopping distances while maintaining as much lateral stability as possible.

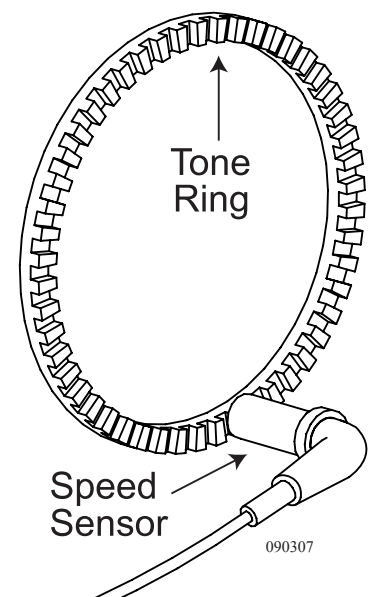

**ABS Warning Lights:** The ABS will perform a dash indicator lamp check and self-diagnostic test each time the ignition is switched to the on position.

- When the ignition is turned on, the ABS indicator illuminates momentarily (2.2 seconds), verifying the self-diagnostic test. If the ABS light illuminates while the motorhome is being operated, there is a fault in the anti-lock brake system on the drive axle or steer axle. This fault will not affect normal service braking. The motorhome will need to go to a service center to repair the problem.

**ABS Diagnostic Button:** By properly actuating the test button on the ABS diagnostic center, system configuration codes and fault codes can be retrieved as blinked sequences on the fault lamp. System configuration codes are sequences of four blinked digits while fault codes are sequences of two blinked digits. Refer to an authorized Eaton/Roadranger for a list of blink code sequences. If the test button is not pressed correctly for a specific readout, stop and start over at the beginning of the procedure. All blink codes are displayed by the ABS warning light only. The ATC light does not display blink codes.

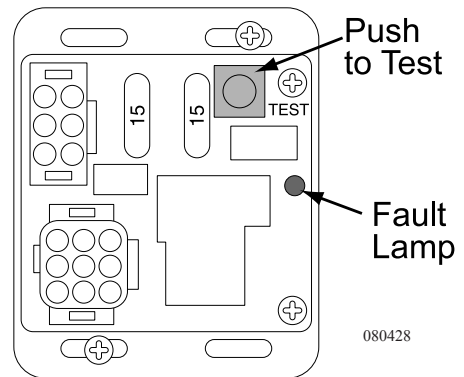

Located in the Front Electrical Panel.

**NOTE:** All blink codes are displayed by the ABS warning light only. The ATC light does not display blink codes.

**NOTE:** Contact a certified Eaton service repair center at (800-826-4357) for more information.

1. Write down system configuration codes and fault codes.
2. If the system configuration is correct, clear the fault codes. The process for clearing the fault codes and reconfiguring the ECU is the same when using the diagnostic button.
3. After clearing fault codes, retrieve the fault codes once again to make sure inactive fault codes were cleared. Only active codes will now be displayed.

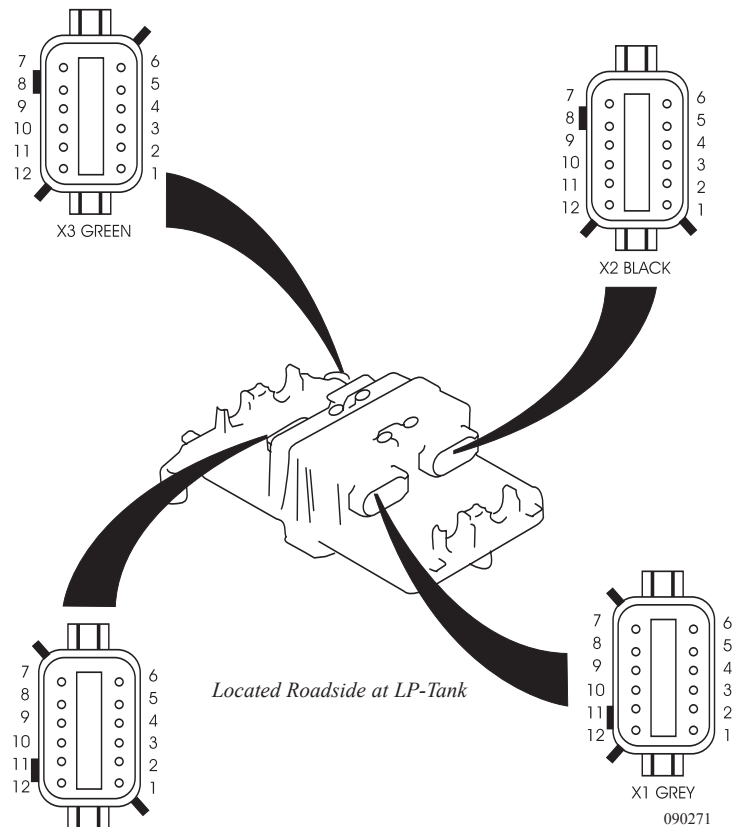

**Reading Configuration Codes:**

1. Turn the ignition key to ON.
2. Apply and release brakes once before proceeding.
3. Press and hold the diagnostic button for two seconds and release, immediately press the diagnostic button a second time for two seconds and release.
4. The four-digit configuration code is retrieved and displayed. It should read 1-2 pause 4-5.

**Retrieving Fault Codes:**

1. Turn the ignition key to ON.
2. Apply and release brakes once before proceeding.
3. Press and hold the diagnostic button for two seconds and release.
4. Two-number blink codes are retrieved and displayed. A two-digit display of 1-1 indicates no faults; the ABS system is functioning properly.

**Clearing Fault Codes and/or System Configuration:**

1. With the ignition OFF, press and hold the diagnostic button.
2. Turn the ignition key to ON while pressing the diagnostic button.
3. Wait two seconds and release the diagnostic button.
4. Press and release the brake pedal.
5. The ECU is reconfigured to match connected components and fault codes are cleared.
6. Repeat the "Retrieving Fault Codes" procedure to verify that fault codes are cleared.

**Disabling ATC for Dynamometer Testing:**

1. Turn the ignition key to ON.
2. Press and hold the diagnostic button for at least 3 seconds and release.
3. The ATC light turns ON and the fault lamp blinks 17-8, indicating the ATC system is disabled. All subsequent flashes are active ABS fault codes.
4. The ATC system will be enabled when the ignition is switched off then back to on.

## Automatic Traction Control System

The ATC (Automatic Traction Control) system improves traction on slippery or unstable road surfaces by limiting excessive drive wheel slip. This is accomplished by limiting engine torque to the drive wheel or engaging a brake to the spinning drive wheel. During normal operation engine torque is not affected. The ATC system works in conjunction with the ABS Electronic Control Unit. The ECU monitors tone ring speed of the drive wheel in relation to the other wheels. If a speed differential occurs in the drive wheel, the ECU enters Automatic Traction Control mode.

During an ATC event, the ECU will automatically react to optimize traction and safety if the motorhome encounters a slippery road surface. Engine torque is normally reduced to limit drive wheel slip.

**NOTE: The ATC system is always active.**

### ATC reacts to drive wheel slip by:

- Reducing engine torque to the drive wheel if road speed is above 25 mph.
- Reducing engine torque and activating drive axle brake controls if road speed is below 25 mph. If the brake control activates, it remains active regardless of road speed.

## How Automatic Traction Control (ATC) Works

If this wheel is spinning due to a slippery surface or because the wheel is off the ground, the ABS system with ATC applies the brake to this wheel.

This wheel then delivers torque to the ground.

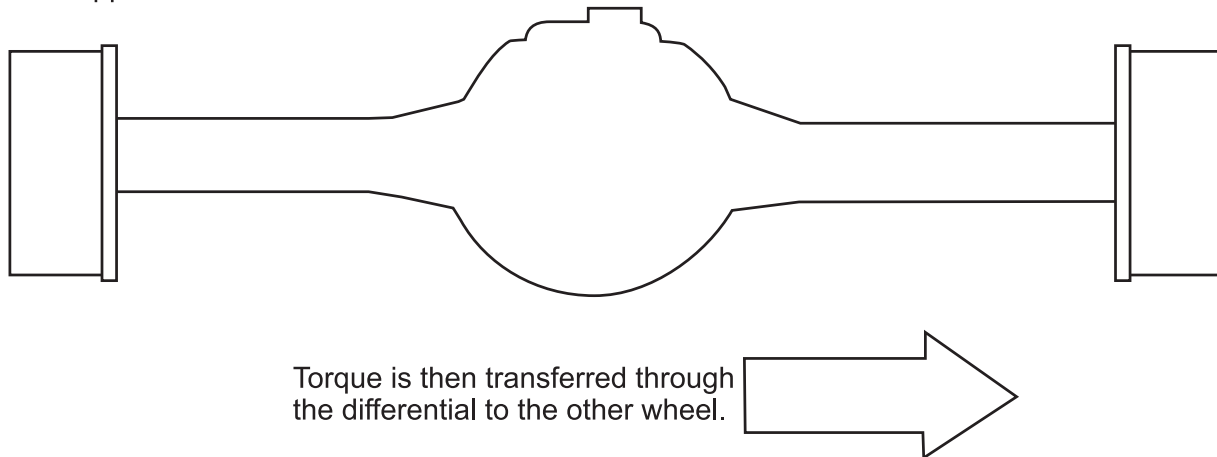

Torque is then transferred through the differential to the other wheel.

090372

**ATC Switch:** Activating the ATC switch reduces ECU control over engine torque. Momentarily pressing the ATC switch allows the ECU to increase the amount of engine torque applied to the drive wheel in an ATC event. The amount of engine torque applied to the drive wheel will vary with the amount of drive wheel slip versus road speed. In an ATC event, the ECU remains active regardless of road speed or switch position. The indicator light flashes slowly when the ATC switch is activated.

**ATC Indicator Light:** During normal operation, the ATC indicator light will illuminate steady when the ignition key is turned ON. The light remains illuminated until the first brake application. If an ATC event occurs, the indicator light will flash quickly. The indicator light will flash slowly if the ATC switch is activated.

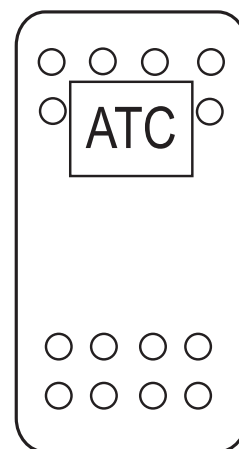

080331

**CAUTION:** Normally the switch should remain inactive. During an ATC event (drive wheel slip) the ECU will automatically optimize drive wheel traction in most situations. Activating the switch during periods of wheel slip can increase torque to the spinning drive wheel. Drive train damage can occur if the spinning drive wheel should suddenly regain traction. If the motorhome is stuck it is advised to call a professional towing company to limit the possibility of body and drive train damage.

## FRONT AXLE

While driving the motorhome, be aware of any changes in the feel of steering and have the system checked if there are any apparent differences. It is normal to hear some hydraulic noise from the steering, especially when the steering is at maximum or while turning the wheel when the motorhome isn't moving. Investigate any unusual or loud noises that occur. Begin by checking the level of the hydraulic fluid level. Traveling at slow speeds over rough surfaces may cause a "clunking" noise to emanate from the steering column, but if noise is heard on smooth surfaces while turning back and forth sharply, the noise should be inspected and a cause determined.

Shimmy and looseness should be checked and corrected as soon as possible. If any looseness is felt in the steering, the steering linkages can be observed while someone turns the steering wheel left and right. Watch the linkages for any evident play or uneven interaction between components to help pinpoint a problem. Have the steering system checked for damage after a severe impact, such as striking large potholes or curbs, and front-end collisions. Observe the alignment of the steering wheel spokes; a change in the alignment may indicate damage to the steering components or suspension.

Maintenance for the system entails adequate lubrication of the system. Use only a hand operated grease gun on the fittings. Grease fittings for the steering system are found on the both ends of the drag link (the bar connecting the steering gear to the axle), and on the steering drive shaft located between the steering wheel and steering gear. The correct wheel alignment promotes longer tire wear and ease of handling while minimizing the strain on the steering system and the axle components. Use NLGI #2 Lithium soap base lubricant for all steering linkage and brake components.

## Alignment Specifications

**Camber:** Camber, as shown, is vertical tilt of wheel as viewed from the front of the vehicle. This is machined into the axle when manufactured and is not adjustable.

- “Positive” camber is an outward tilt of the wheel at the top.
- “Negative” camber is an inward tilt of the wheel at the top.

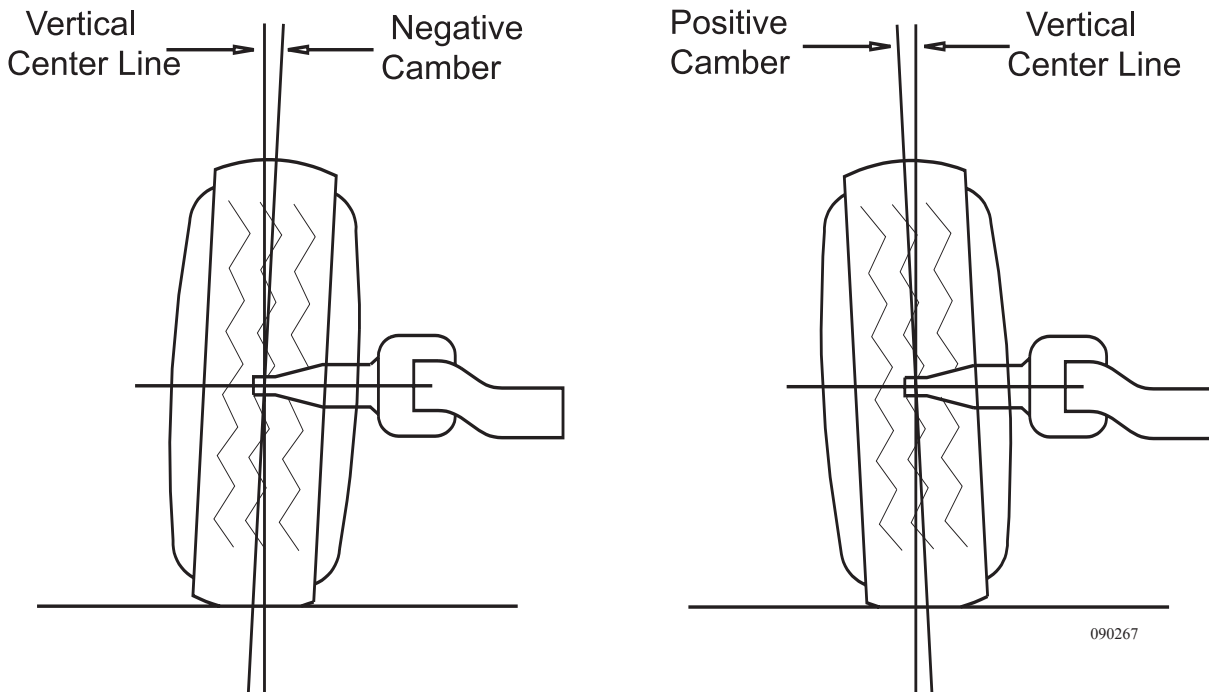

**Toe Setting:** The toe setting represents different distances between the front and rear of the tires (measured at the vertical center line of the tires).

**Toe-in:** Occurs when the tire front distance is less than the tire rear distance.

**Toe-out:** Occurs when the tire front distance is greater than the tire rear distance.

Wheels are generally set with initial toe-in. As the vehicle operates tires tend toward a toe-out condition. By starting with an initial toe-in setting, a desirable “near zero toe-in” can be achieved when the vehicle is in motion.

Incorrect toe settings, where toed-in or toed-out, can have a significant affect on tire wear. The toe setting is adjusted by lengthening or shortening the cross tube.

### FRONT OF MOTORHOME (Top View of Axle)

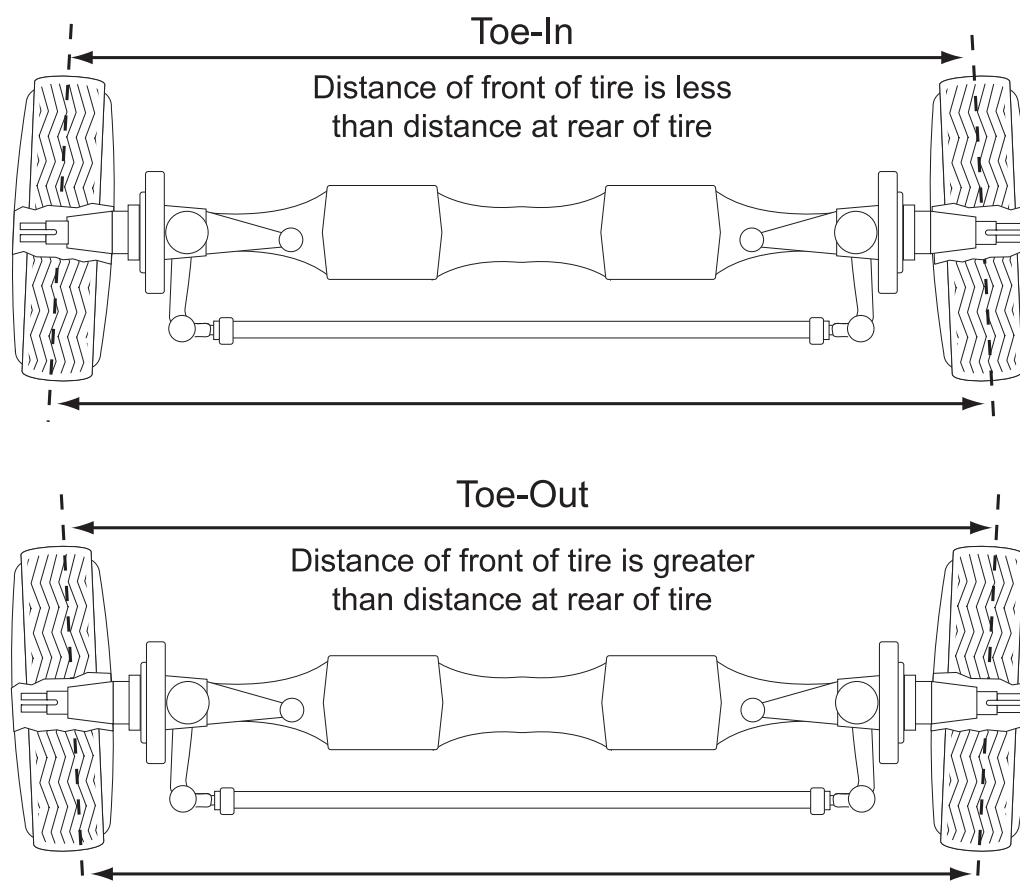

090265

**Caster Adjustments:** Caster is the fore and aft tilt (toward the front or rear of the motorhome) of the steering kingpin as viewed from the side of the motorhome.

“**Positive**” caster is the tilt of the top end of the kingpin toward the rear of the motorhome.

“**Negative**” caster is the tilt of the top end of the kingpin toward the front of the motorhome.

Setting the caster angle more positive than specified may result in excess steering effort and/or shimmy. Decreasing the angle may result in vehicle wander or poor steering return to center. The caster angle is determined by the installed position of the steer axle.

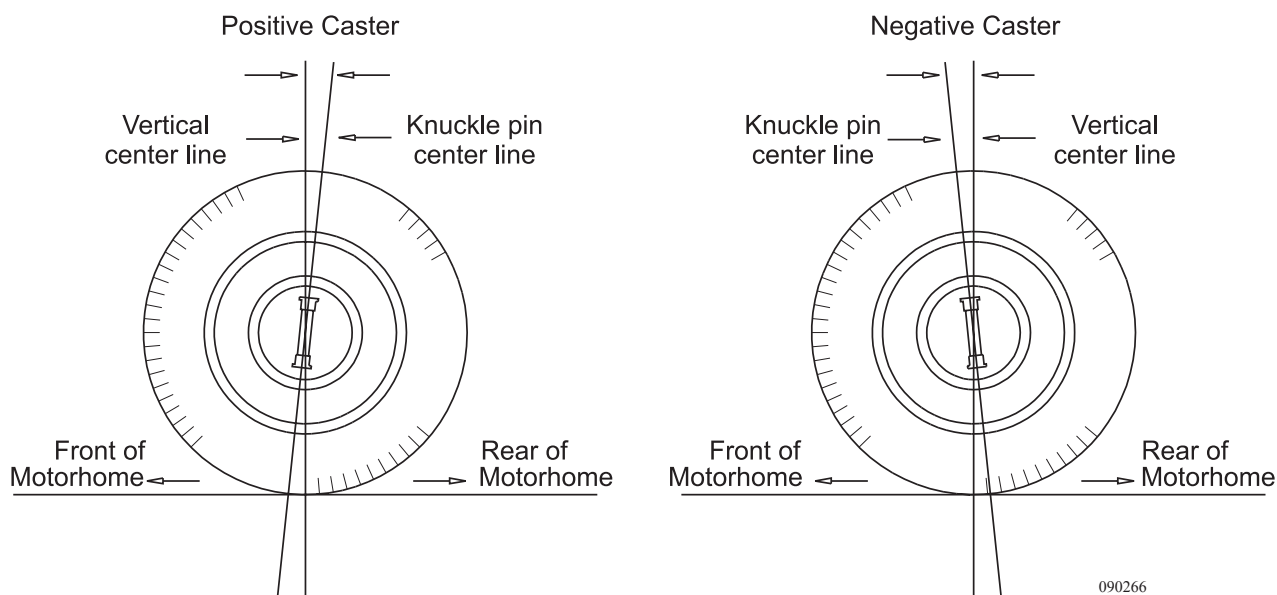

090266

		SPEC	TOL
<b>LEFT FRONT</b>	<b>CAMBER</b>	0.00°	0.40°
	<b>CASTER</b>	6.00°	0.50°
	<b>TOE</b>	0.03°	0.12°
<b>RIGHT FRONT</b>	<b>CAMBER</b>	-0.25°	0.40°
	<b>CASTER</b>	6.00°	0.50°
	<b>TOE</b>	0.03°	0.12°

### Lubrication Maintenance Safety

The front axle components require periodic lubrication maintenance. Chock the wheels for safety prior to accessing components underneath the motorhome.

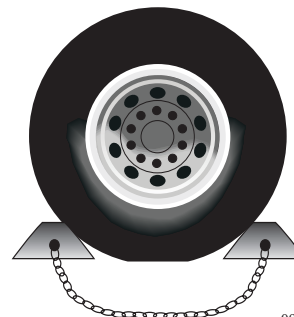

090368b



**Steering Components**

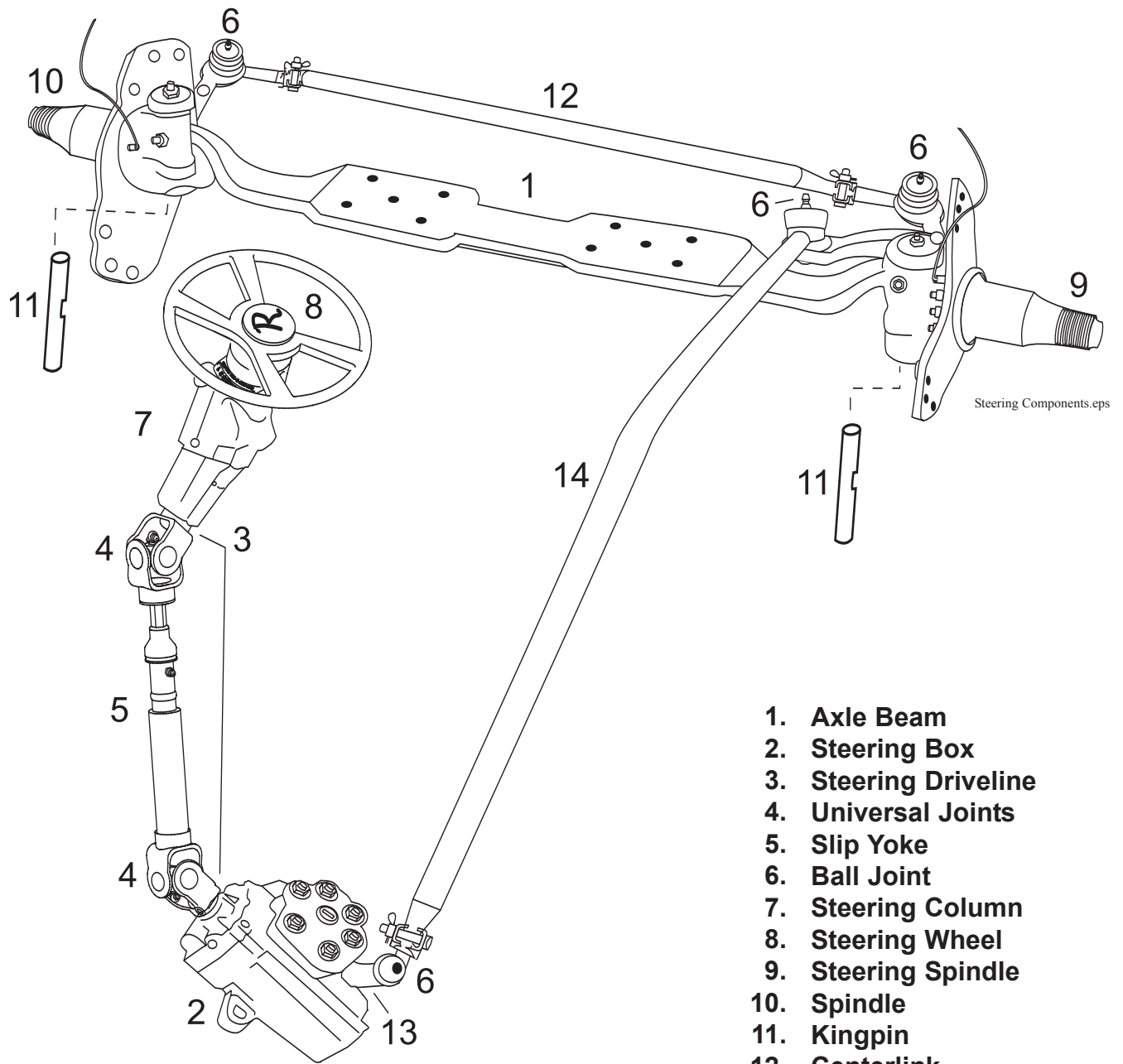

Steering Components.eps

- 1. Axle Beam
- 2. Steering Box
- 3. Steering Driveline
- 4. Universal Joints
- 5. Slip Yoke
- 6. Ball Joint
- 7. Steering Column
- 8. Steering Wheel
- 9. Steering Spindle
- 10. Spindle
- 11. Kingpin
- 12. Centerlink
- 13. Pitman Arm
- 14. Drag Link

TYPICAL

## Intermediate Steering Shaft

The steering wheel connects to the steering box using a driveline. Service the steering drive shaft universal joints and slip yoke every 30,000 miles or annually. Remove the steering column cover to access the upper universal joint and slip yoke. The lower universal joint is accessed from underneath in the generator compartment behind the front electrical box.

### Greasing the Steering Shaft Universal Joints:

1. Check the steering shaft for looseness. If loose or worn, repair the drive shaft as necessary.
2. Apply the specified grease at the grease fitting on the universal joint.  
Apply new grease until the new grease purges from all the seals.
3. If the new grease does not purge from the seals, disassemble and clean the joint or replace the universal joint. Do not lose any of the needle bearings.

### Greasing the Steering Shaft Slip Yoke and Splines:

1. Check the steering shaft for looseness. If loose or worn, repair the drive shaft as necessary.
2. With finger, cover the rear air hole so grease flows to the front seal. Apply the specified grease at the grease fitting on the slip yoke. Apply grease until new grease purges and forces finger away from the air hole in the end of the slip yoke. Greasing interval is yearly or every 30,000 miles.

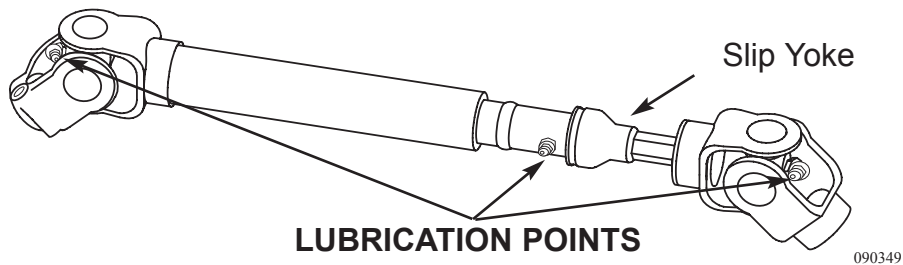

## Drag Link

The drag link connects the steering box pitman arm to the steer axle. The movable joint (ball joint) uses sealed boots to prevent water intrusion. Do not rupture the boot when applying grease. Grease interval is six months or every 5,000 miles.

**NOTE: It will be necessary to start the motorhome and turn the steering wheel to access fitting(s).**

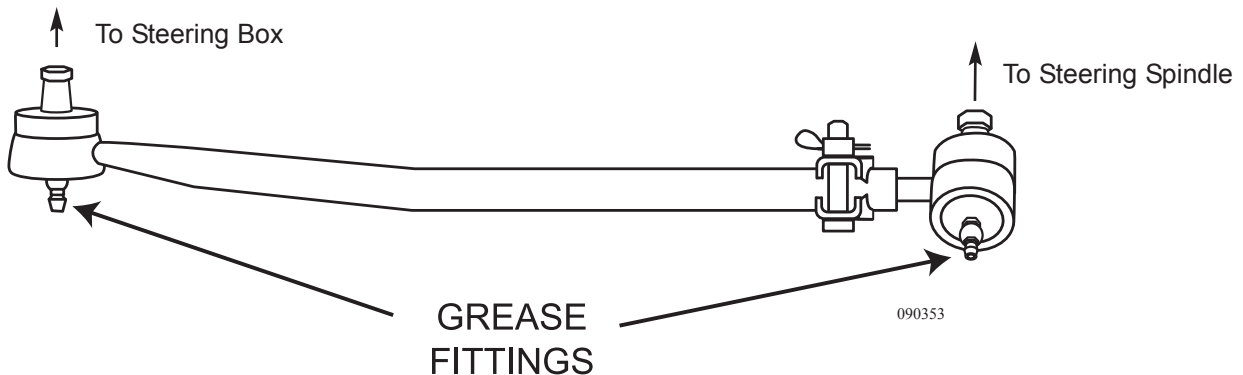

The center link is located on the backsides of the steer axle. The center link attaches the two wheels together causing the right front to track with the left front. Greasing interval is every six months or 5,000 miles.

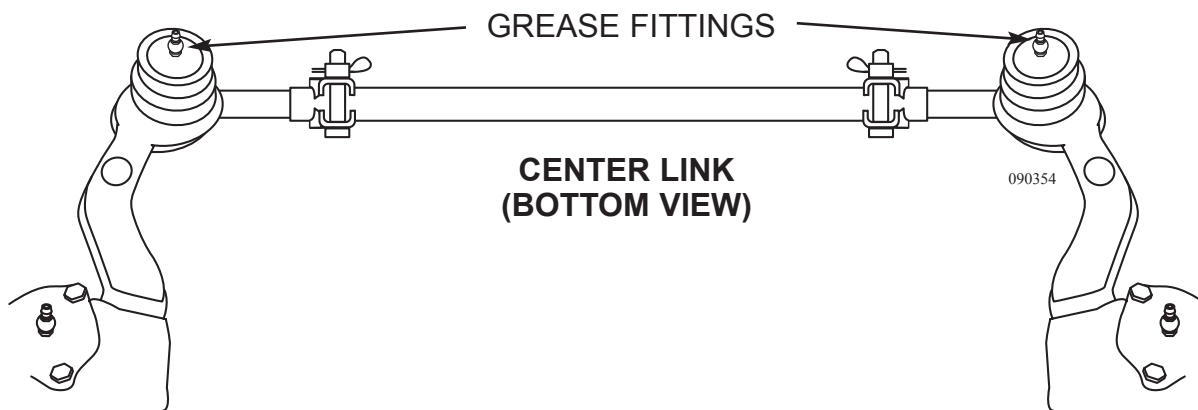

### **Steering Spindle**

The steering spindles attach to the front axle and pivot on the kingpin. The wheel end assembly and brake system attach to the spindle. There are upper and lower lubrication points for the kingpin. The drag link attaches to the roadside spindle. After initially lubricating the roadside and curbside kingpins, rotate the steering assembly lock to lock (full left to right) then move assembly back to center. This purges any remaining air pockets. Continue lubricating the kingpins until new grease purges with no air pockets. Greasing interval is every six months or 5,000 miles.

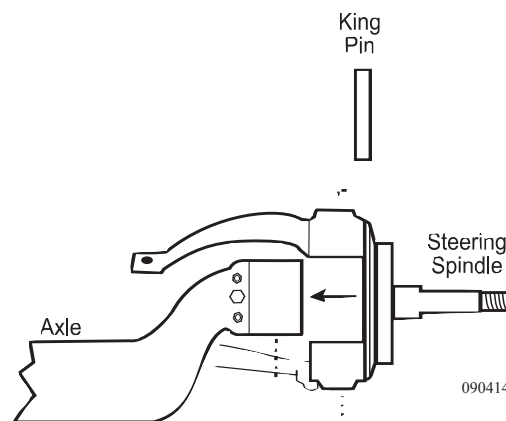

### **Control Arm Bushings**

Control arms align the axles perpendicular with the frame. The panhard bar controls side to side motion of the axles in the frame. Control arm bushings and panhard bar bushings do not require lubrication.

## Front Brakes

The slack adjuster and camshaft need to be lubed periodically to ensure proper brake operation. Lubricate every 10,000 miles or annually.

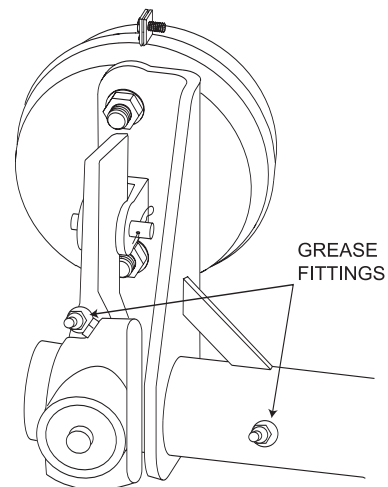

**Typical Air Drum Brakes -**  
*Lubricate until new grease appears at exit points.*

## DRIVE AXLE & DRIVE SHAFT

**Drive Axle:** The chassis drive axle is a single reduction axle, with a gear ratio of 4.30:1. The differential gears consist of a hypoid pinion and ring gear set and bevel differential gears. The differential carrier can be removed from the axle housing as a unit in order to perform repairs.

All power from the engine to the rear tires is transferred through the rear axle. For this reason, it is important that maintenance be performed on the axle as required to avoid premature wear of the gears and bearings in the axle.

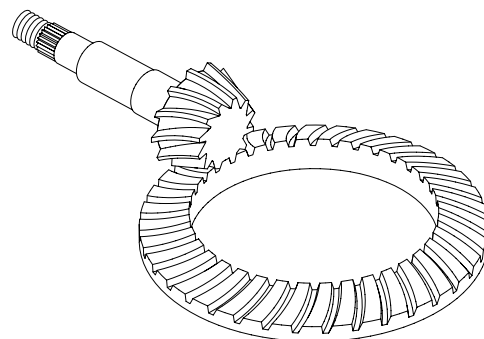

**Drive Axle Lubricant:** The rear axle is filled with synthetic gear oil meeting MIL-L-2105D specifications. Change interval is every 250,000 miles, or 36 months, whichever occurs first.

During lubricant change, fine metal particles will be observed clinging to the magnetic fill and drain plugs of the axle. These particles are normal wear particles from the axle components, but will cause faster than normal wear of the axle components if allowed to circulate through the lubricant. It is recommended that the magnetic plugs be tested, if not replaced, at each lubricant change when petroleum-based lubricants are used, or every 100,000 miles when synthetic lubricant is used. These plugs should have sufficient magnetic strength to pick up a 1.5-pound weight of low carbon steel. Never replace a magnetic plug with a non-magnetic "pipe plug" as they will not keep the lubricant clear of metal particles or seal properly.

The level of lubricant in the rear axle should be checked every 30,000 miles or annually, whichever comes first. This will ensure adequate lubricant in the axle for proper operation.

#### **Proper Drive Axle Lubricant Level:**

- Regular inspection of the drive axle lube levels is an essential maintenance procedure.
- Clean the area around the fill plug, which is located about halfway up the axle housing bowl.
- Remove the fill plug and observe the lubricant level.
- The lubricant should be level with bottom of the hole.
- Important: The lube level close enough to the hole to be seen or touched is not sufficient. The lube must be level with the hole.
- Correct the level as necessary.
- Re-install the fill plug and tighten to 35-50 ft-lbs.

**NOTE: When checking the lube level also check the housing breathers. Clean the breathers if dirty or replace them if damaged.**

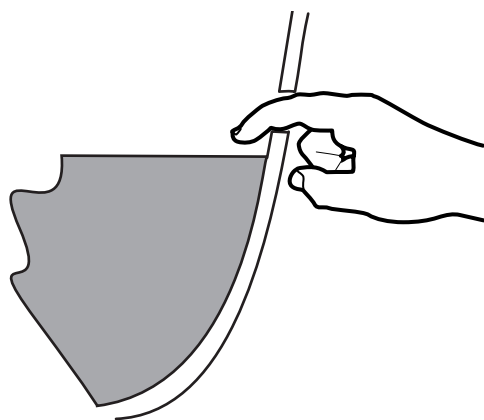

Incorrect Oil Level

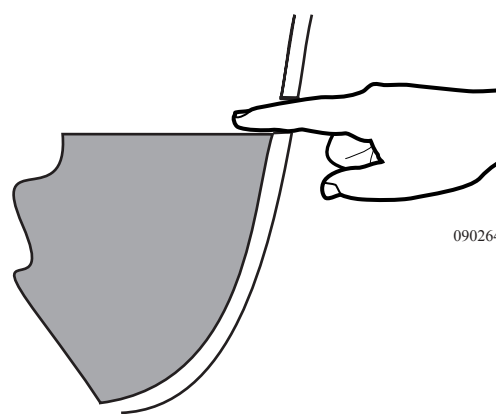

Correct Oil Level

090264

**To Drain and Replace Lubricant:** With vehicle parked on a level surface and rear axle warm, place a large container under axle.

1. Remove drain plug and allow axle to completely drain.
2. Properly dispose of oil.
3. Clean the drain plug and test (replace the drain plug if needed).
4. Install and tighten drain plug to 35-50 ft-lbs.
5. Clean the area around the fill plug from the axle-housing bowl.
6. Fill the axle with approved lubricant until the level is even with the bottom of the fill plug hole.

**WARNING:** When checking or changing the lubricant, always ensure that the axle is not "hot." Oil temperature 90° or hotter can easily cause severe burns.

---

## Lubrication Maintenance

The slack adjuster and camshaft need to be lubed periodically to ensure proper brake operation. Lubricate every 10,000 miles or annually.

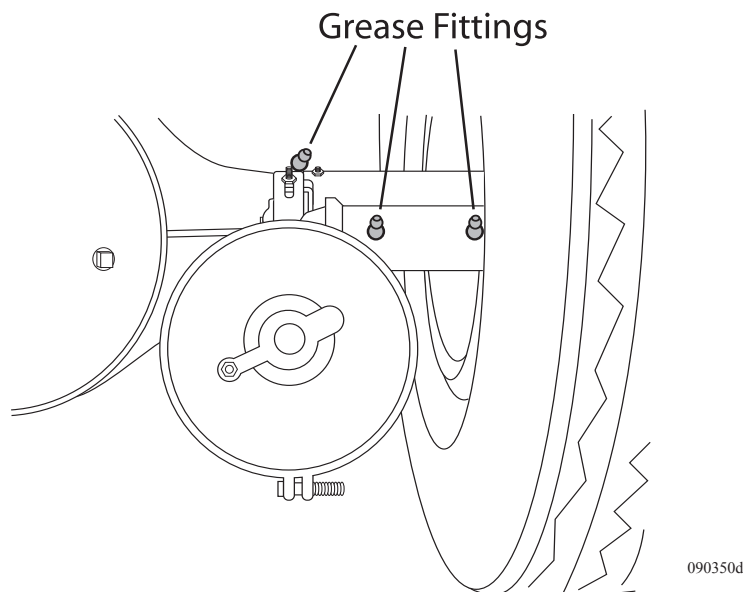

**Rear Drum Brake -**  
*Lubricate until new grease appears at exit points.  
Use NLGI #2 Lithium Soap base grease.*

**Drive Shaft:** The drive shaft transfers power produced by the engine to the drive axle. A worn or out of balance driveline causes chassis vibration that generally increases in intensity with road speed.

**NOTE:** It will be necessary to move the motorhome forward or backward to access all fittings on the drive shaft.

#### Greasing the Drive Shaft Universal Joints:

1. Check the drive shaft for looseness. If loose or worn, repair the drive shaft as necessary.
2. Apply the specified grease at both grease fittings on the universal joints. Apply new grease until new grease purges from all the seals.
3. If new grease does not purge at the seals, loosen (Do Not Remove) the bearing cap bolts and re-grease until all four caps purge. If new grease still does not purge, disassemble and clean or replace the universal joint.

#### Greasing the Drive Shaft Slip Yoke and Splines:

1. Check the drive shaft for looseness. If loose or worn, repair the drive shaft as necessary.
2. With finger, cover the rear air hole so grease flows to the front seal. Apply the specified grease at the grease fitting on the slip yoke. Apply grease until new grease purges and forces finger away from the air hole in the end of the slip yoke. Greasing interval is 10,000 miles or annually.

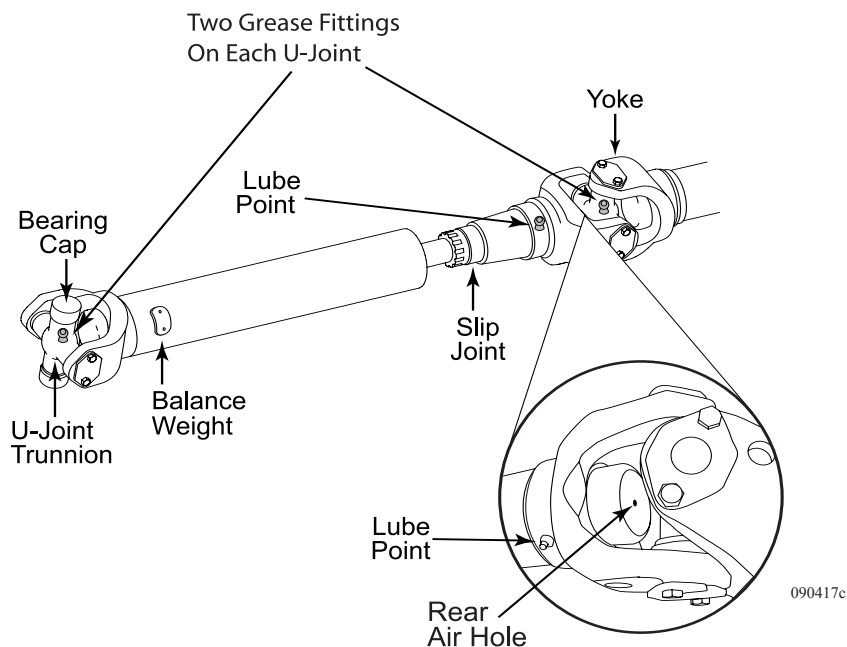

**WARNING:** Rotating shafts can be dangerous. Rotating shafts can snag clothes, skin, hair, hands, etc. causing serious injury or death. Do not work on or near a shaft “with or without a guard” when the engine is running.

## U-Joint Angles Phasing & Driveline Balance

Correct U-joint working angles U-joint phasing, and driveline balance is vital to maintaining a quiet-running drivetrain and long life of drivetrain components (including driveline components).

When in phase, the slip yoke lugs (ears) and tube yoke lugs (ears) are in line. Normally this is the ideal condition and gives the smoothest running shaft. There may be an alignment arrow stamped on the slip yoke and on the tube shaft to assure proper phasing when assembling these components. If there are no alignment marks, they should be added before disassembly of the shaft to assure proper reassembly.

Phasing is relatively simple on a two-joint set, be sure that the slip yoke lugs and the tube yoke lugs are in line.

The U-Joint working angle is the angle formed by the intersection of the driveshaft centerline and the extended centerline of the shaft of any component to which the U-joint connects. Because the double oscillating motion of a U-joint that connects angled shafts causes a fluctuating speed difference between the shafts, the effect created by the U-joint at one end of the shaft must cancel the effect created by the U-joint at the other end. This is done by making U-joint working angles at both ends of the driveshaft about equal, with the U-joints in phase. If the yoke lugs at both ends of the shaft are lying in the same plane (a plane which bisects the shaft lengthwise), the U-joints will be in phase.

Any condition which allows excessive movement of a driveshaft will cause driveline imbalance: loose end yoke nuts, loose U-joint bearing cap retaining capscrews, worn U-joint trunnions, bearings and worn slip-joint splines.

Among the most common causes of U-joint and slip joint damage is lack of lubrication. To keep the motorhome operating smoothly and economically, the driveline must be carefully checked and lubricated at regular intervals.

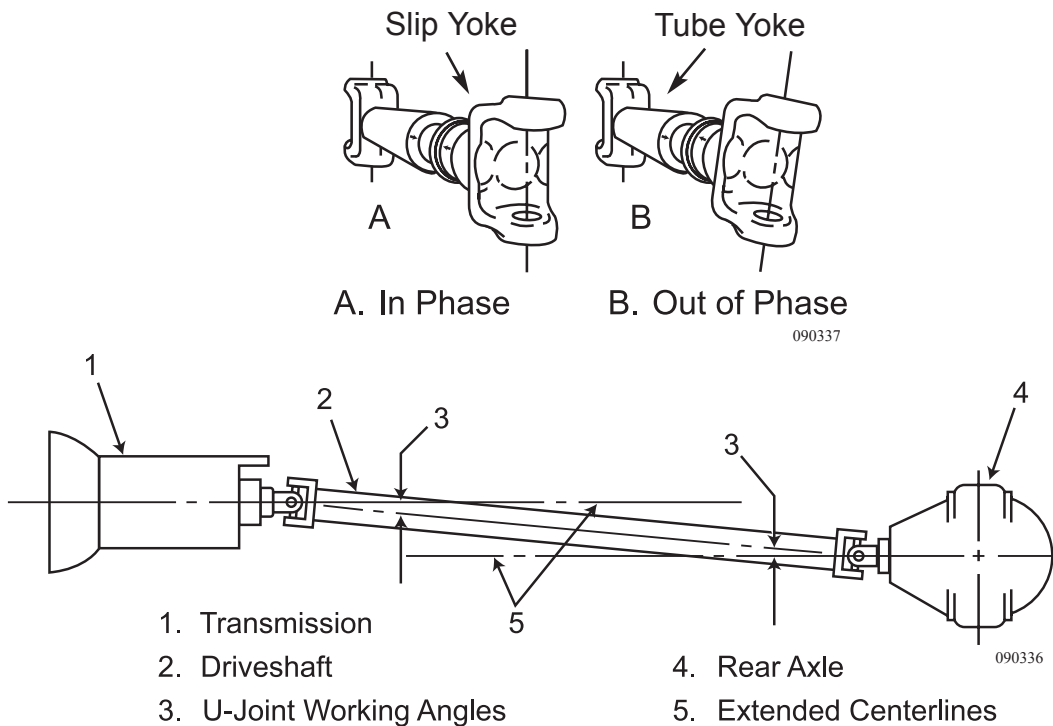



## SHOCK ABSORBER

The shock absorber by definition is a hydraulic device used to dampen suspension/body movement. Road surface irregularities are compensated for by the shock absorber. The roadmaster chassis incorporates the shock absorber in the design of the exclusive air glide suspension system. This shock absorber is a telescopic, mono tube unit filled with nitrogen gas and hydraulic oil. The result of the mixture is uninterrupted damping for the smallest of wheel deflection.

By design, a self lubricating seal is used which will allow about 10% of the total oil capacity to pass onto the piston rod. The gradual process of oil loss does not affect the performance of the shock absorber during the service life. This process will be evident after a long period of service by an oil film on the body of the shock absorber. The appearance of a coating or film on the body or rod is completely normal, it is an indication the shock is functioning normally.

Road holding, handling, balance and braking characteristics all can be contributed to the shock absorber. The operating conditions for which the shock absorber must endure will determine the life span. However, since the only moving part is the piston rod, there are no springs, hinges or pins to wear out, get weak or deteriorate.



090315

## LEVELING SYSTEM - *Hydraulic Leveling RVA*

The three point leveling system features a multiple warning system with flashing lights and a bong alarm to alert you of the jack position. The system also features a remote control location from the driver seat.

The model J-II leveling system pump is located in the roadside compartment behind the rear wheel. The valve assembly manifold is mounted on the pump motor, providing easy access to the manual retract valves. The system is designed to be self bleeding in the event any component of the hydraulics has been removed or repaired. Fully extend and retract each jack twice. The remote rocker switches will operate with a minimum of 7.5 Volt DC. Optimum requirements for operating the system are voltages above 9.6 Volt DC.

**CAUTION: Hot asphalt may not support the weight that is placed on the hydraulic jack pads. Place thick plywood under the jack pads to help disperse the weight. Never use the leveling system to support the entire weight of the motorhome. Damage from excessive torsional twists can result.**

**CAUTION: If blocking up a rear jack pad to gain added clearance while the motorhome is on a slope, chock the opposite side rear wheels to prevent the motorhome from rolling.**

**WARNING: Using an improper leveling process can result in applying excess torsional stress to the chassis and body resulting in damage to the windshield or entry door malfunction. The leveling system jacks are not designed for changing tires. This can cause problems with the suspension system, frame alignment and damage to the windshields. Never use the jacks to elevate any wheel position off the ground.**

## Manual Leveling System

When manually operating the leveling system, always lower the front jack first. The front jack acts as a pivot point for the chassis and reduces torsion stress on the body of the motorhome.

**NOTE: If the front of the motorhome is high and does not require elevating, raise front of motorhome a minimum of ½ inch to allow jacks to act as a pivot point.**

The leveling system was designed to reduce site selection problems. If possible, park the motorhome with the front facing downhill. If the ground is soft, place a wooden 2 x 8 board under the foot of each jack pad to prevent sinking.

The front jack is the pivot point for the chassis and always lowered first to reduce torsion stress on the body of the motorhome. The Bong alarm will activate when any jack is extended more than 2" to 6" from fully retracted position and indicate low fluid level in the pump motor. The Bong alarm may momentarily activate when driving over rough roads, or negotiating curves and corners, to indicate low fluid level.

- Place the gear selector in PARK.
- Apply the parking brake.
- Turn the ignition switch to the ON position.
- Switch the main jack control power switch ON.
- To extend a particular jack, push the appropriate rocker switch to extend position and hold it until the desired extension is reached.
- To retract a particular jack, push the rocker switch to the retract position and hold until the desired retraction is reached.
- Turn OFF the switch labeled POWER on the jack control panel.
- Turn OFF the ignition switch.

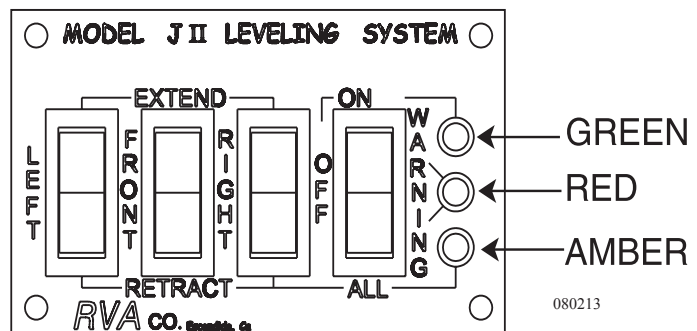

## Retracting Leveling Jacks

- Ensure the gear selector is in PARK.
- Ensure the parking brake is applied.
- Turn the ignition switch to the ON position.
- For manual control of the system, switch the control panel power switch ON.
- To retract a particular jack, push the rocker switch to the retract position.
- All jacks may be retracted by selecting the ALL position on the power switch.

**CAUTION: Damage to the mud flap may occur if the mud flap is located over a raised area when the suspension is lowered.**

**NOTE: Do not move the motorhome until the jacks are fully retracted. Visually check the jacks to ensure full retraction. Do not rely solely on the lights and alarms.**

**Manual Override Retract Valves**

In the event of mechanical or electrical failure that would prevent the leveling jacks from being automatically retracted, the motorhome is equipped with manual emergency retract valves. These valves are located inside the roadside compartment behind the rear wheel. The manual system will release fluid under pressure in each jack and allow fluid to return to the reservoir. The jacks will then retract.

To operate the manual system, turn all three valves counterclockwise until they stop. Once the jacks are fully retracted, rotate all the valves fully clockwise. In the event one of the jacks is not holding pressure, check to make sure all valves are fully closed.

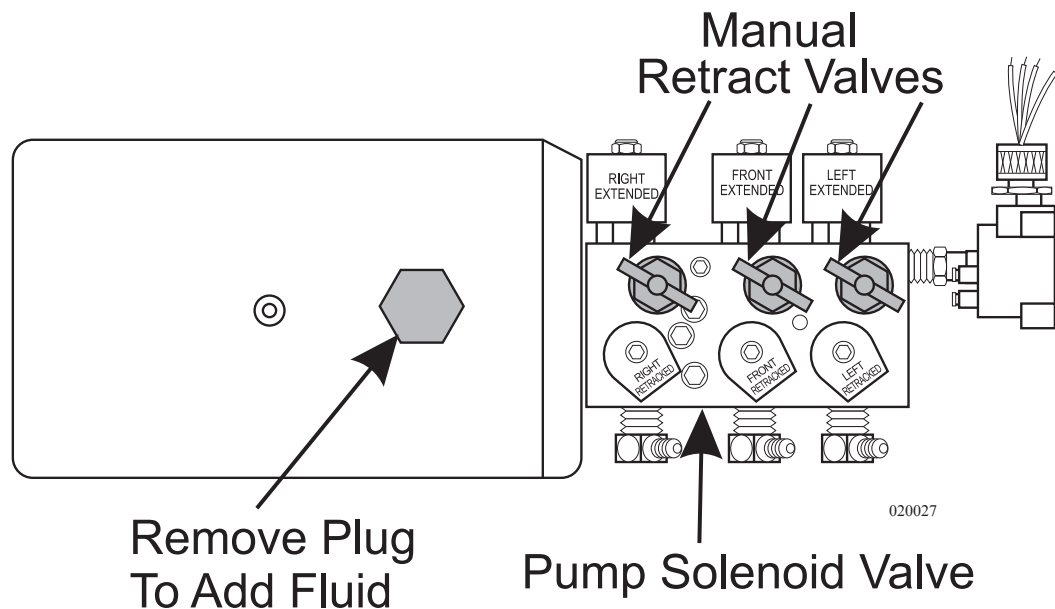

Occasionally, while the jacks are fully extended, wipe dirt from the jack rod. This will help lengthen the life of the jacks. This can vary from the amount and type of usage of the jacks. Dexron III will serve as a solvent as well as a lubricant. Occasional oil or grease on the extended jack ram is normal and aids in the lubrication of the ram. It helps to learn the sound of the normal pumping and gurgling sounds of the pump when it is low on fluid.

**Adding Fluid:**

1. Use Dexron III automatic transmission fluid.
2. Extend any jack six inches from the full retracted position. All other jacks should be fully retracted.
3. Unscrew the reservoir cap from the top of the pump.
4. Turn the ignition switch to the ON position. Turn the rocker switch to ON. Open the window so the bong alarm is audible from outside the motorhome. Slowly fill the reservoir with fluid until the bong alarm stops sounding.
5. Replace the reservoir cap.
6. Turn the ignition switch and the remote panel OFF.

## ENGINE - GENERAL INFORMATION

The diesel engine operates differently from the conventional gasoline engine. Gasoline engines control engine speed using a butterfly throttle plate controlling air/fuel mixture inlet flow. As the throttle plate opens, vacuum created by the piston velocity draws the metered fuel/air charge into the combustion chamber, then ignites from a controlled electric ignition source. Closing the throttle plate limits the fuel/air supply, slowing engine speed, increasing intake manifold vacuum.

The diesel engine in the motorhome controls engine speed by varying fuel supply only. No throttle plates are used. An exhaust driven turbine system (turbocharger) compresses the fresh air supply into the engine. The fuel is injected under pressure into the combustion chamber. Ignition of fuel/air charge occurs from heat generated by rapid high compression. The turbo boost gauge registers amount of intake manifold pressure measured in lbs./in<sup>2</sup>. Therefore, no intake manifold vacuum exists.

Diesel engine RPM (revolutions per minute) operating speeds are generally much lower than that of the gasoline engine. Peak torque and horsepower output values occur at much lower engine speeds. Idle speeds between the two engine types are similar, however maximum engine speeds are quite different. The gasoline engine generally is not regulated to a maximum engine speed. The maximum engine speed on a diesel engine is controlled by an engine speed governor set by the engine manufacturer.

**WARNING: Do not operate a diesel engine where there are or can be combustible vapors. Vapors can be drawn through the air intake system and cause engine acceleration and over-speeding, resulting in fire, explosion and extensive property damage. Numerous safety devices are available, such as air intake shutoff devices, to minimize risk of an engine over-speeding where an engine (due to its application) might operate in a combustible environment, such as fuel spills or gas leaks.**

**INFORMATION: The equipment owner and operator is responsible for safe operation of engine. Consult your engine manufacturers owners manual or authorized repair location for more information.**

The Cummins diesel engine is a 6-cylinder in-line engine, utilizing an electronic fuel control system to supply fuel to the cylinders for precise fuel delivery, as well as built-in diagnostics to monitor engine operation.

Engine electronics also enable the use of programmable monitoring features that may cause limited engine power/vehicle speed when certain conditions arise. These features limit the operation of the engine when conditions that may damage the engine are encountered. These conditions may include such events as low oil pressure and high coolant temperature. When the engine electronics encounter such a condition, it limits the amount of power produced by the engine to help prevent or limit damage. It is possible however, for the engine to be damaged if corrective action is not taken immediately when such a condition exists.

---

Operation of the vehicle while in the limited operation mode may result in serious engine damage. If a sudden loss of power is noticed in conjunction with the engine warning light illuminating **STOP ENGINE**, pull to the side of the road as soon as it is safely possible. Evaluate the situation.

Refer to the engine manufactures OEM for additional information concerning the operation, description, maintenance, and warranty information for the engine.

**Diagnostic Fault Codes:** The engine ECM will record three types of fault codes; Electronic Control System Faults, Protection System Faults and Maintenance Indicators. All faults recorded will be **ACTIVE** or **INACTIVE**. Not all faults will light an indicator when they are **ACTIVE**.

### **Three Lamps that Can Illuminate Are:**

**Engine Warning** - Indicates a need to repair the fault at the first opportunity.

**Stop Engine** - Indicates a need to shut down and remain shut down until the fault can be repaired.

**Maint Reminder** - Indicates a maintenance function needs to be performed.

### **Eng Diagnostic:**

Uses the Engine Warning and Stop Engine dash warning lamps to emit engine diagnostic codes.

**NOTE:** To retrieve engine diagnostic codes requires an Insight Diagnostic Display or a Shorting Plug hooked to the engine diagnostic harness.

### **To Retrieve Active Fault Codes:**

1. Turn the ignition key **OFF**.
2. Hook up an Insight diagnostic display or Shorting Plug to the engine diagnostic harness.
3. Turn the ignition key **ON**; observe **Engine Warning** and **Stop Engine** lamps.
  - a. If no active codes are recorded, both lamps will remain illuminated.
  - b. If an active code is recorded, both the **Engine Warning** and **Stop Engine** dash warning lamps will illuminate briefly then go out followed by the **Engine Warning** lamp illuminating briefly. This is an indication one or more fault codes will be displayed by the **Stop Engine** lamp. A three-digit code group will display as a series of blinks-pause-blinks-pause-blinks-pause. Record the code(s) as a three-digit number. Codes are separated or ended by the **Engine Warning** lamp flashing once.
  - c. Use the **Fast Idle** switch to scroll through all **ACTIVE** faults.
  - d. When codes are retrieved, turn **OFF** the **Engine Diagnostic** switch.
  - e. Contact *Cummins* help line, **1-800-DIESELS**, or an authorized distributor.

---

## STARTING PROCEDURE - Normal Starting

The engine is equipped with an intake manifold grid heater. The grid heater helps engine starting in cold weather. Intake manifold air temperature is monitored by the Electronic Control Module (ECM) on the engine. If intake manifold temperature is below specified level (about 40° F) manifold grid heater will be activated. Grid heater activation is indicated by the **WAIT TO START** indicator lamp.

**WARNING: Use of ether starting fluids may cause an explosion upon grid heater activation.**

With the throttle at idle position, turn the ignition key to the **ON** position allowing the **WAIT TO START** lamp to extinguish. Turn the key to the **START** position. When the engine is started, the grid heater will again energize for a time period determined by the intake air temperature and fuel temperature. Allow the engine to idle with no load for three to five minutes. The engine coolant temperature should be up to normal operating range (140°F/60°C to 212°F/100°C) before operating the engine under full throttle.

---

### Cold Weather Starting

Starting and operating the motorhome during cold weather requires extra care and consideration. Use the following guidelines and refer to the *OEM Engine Manual* to help ensure safe, trouble-free operation of the motorhome:

The Block Heater requires 120 Volt AC to operate. Hook to shore power, as this is more efficient. The generator may be difficult to start and the time required to pre-heat the engine may be lengthy. The block heater receptacle is located inside the rear engine access doors along the left side. The block heater is rated at 1000 watts.

An extension cord may be used, however, the power cord should be rated at 15 Amps and the outlet used is GFCI protected rated at 20 Amps. The engine may require several hours of pre-heating prior to starting. It is recommended to start pre-heating the engine the night before departure. Remember to unplug the block heater before departure.

**To Use the Block Heater:** Hook to a shore power receptacle and plug in block heater cord.

**WARNING: All extension cords require a UL rating. Used only a 15 Amp, 120 Volt AC extension cord.**

**NOTE: The inverter should never be used for the power source. Rapid battery drain and inverter shut down will occur.**

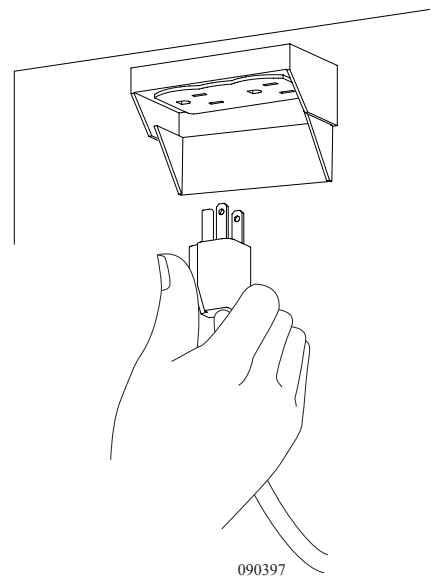



1. When operating below 32° F, an engine block heater or other means to warm the engine can enhance engine starting. This will ease cranking and help prevent engine misfiring and white smoke during starting.
2. Always follow the recommended oil, fuel, and coolant specifications as outlined in the OEM Engine Manual. Proper oil viscosity and coolant concentration eases engine starting and helps to avoid engine damage.
3. Allow the engine to idle until it warms sufficiently for operation. Utilize the fast idle feature to quicken the process. Wait to operate the vehicle for at least three minutes or until the coolant temperature begins to move.
4. Check the air inlet and filter daily, or as necessary, when driving in snow conditions.
5. The demand on batteries increase during winter; check and service the batteries frequently to help ensure trouble-free starts.
6. Start out slowly with the motorhome to allow the transmission and axle lubricants time to circulate and warm before putting them under full load.

**WARNING: Do not use ether cold starting aids to start the engine as damage may occur.**

---

## OIL RECOMMENDATIONS

Following the maintenance guidelines in the engine manufacturer OEM Manual recommendations for the engine will help to extend engine life and improve performance, resulting in cost efficient operations. A good maintenance schedule begins with a daily awareness of the engine and its various systems.

A high grade 15W-40 multiviscosity heavy duty lubricating oil meeting Cummins Engineering Specification CES 20071 or CES 20076, American Petroleum Institute (API) specification CH-4 which can be used as an alternative to CES 20071 is recommended. Lubricating oils meeting API CG-4 specifications may be used at a reduced drain interval. The engine uses Pennzoil 15W-40 heavy duty engine lubricating oil that meets Cummins specifications. A critical factor in maintaining engine performance and durability is the use of high grade multigrade lubricating oil and strict adherence to the maintenance service intervals.

A straight weight or monograde lubricating oil is not recommended. Shortened drain intervals may be required as determined by a close monitoring of the lubricating oil condition by means of an oil-sampling program. The use of oil analysis to extend drain interval is not recommended. There are numerous variables, which is the basis of the recommendation. Synthetic oils API category III specifications are recommended for extreme cold temperatures only. Low viscosity oils, used for winter operations, will aid in starting. Synthetic oils, or oil with adequate low temperature properties used for Arctic operations where the engine cannot be kept warm when shut down, will aid in starting.

The use of synthetic oils should not be used to extend drain intervals. Extended oil change intervals can decrease engine life and possibly affect the engine warranty. Oil additives should not be used unless the oil supplier or oil manufacturer has been consulted and provided positive evidence or data establishing satisfactory performance in the engine.

**NOTE: The engine does not require a "break-in" procedure.**

**Function of Engine Oil:** Lubricating oil in an engine must be capable of performing various functions. Lubrication of the moving parts is the primary function. The lubricating oil should be able to form a film between metal surfaces preventing metal to metal contact and reducing friction. When there is a metal to metal contact, friction heat is generated. Welding of the part can occur and metal transfer will result in scuffing or seizing. The film of oil contacting the surfaces will provide cushioning and shock dampening as well.

Cleaning is another function. The oil should perform as a cleaner in the engine by flushing contaminants from critical components. These contaminants should be removed in the filtration system or during the course of an oil change. Oil will provide a protective barrier to prevent corrosion of non-like metals.

Internal components of the engine require cooling. The primary coolant system cannot provide this cooling. Oil will transfer heat by contacting the various components then transferring to the primary cooling system at the oil cooler. The uneven surfaces in the combustion chamber are filled to act as a combustion seal within the cylinder liner and other internal components.

**Synthetic Engine Oil:** In extreme environments, where ambient temperatures can be as low as 45° C (-50° F), a petroleum-based oil will not perform satisfactorily in diesel engines. Synthetic oils were developed for these type applications. These synthetic oils are blend from ether and/or hydrocarbon based oils. Chemically reacting lower molecular weight materials to manufacture lubricants of desired properties produce these base oils. All synthetic based oils must meet the API category III classifications and SAE viscosity grades.

**NOTE: Synthetic oils and petroleum based oils should never be mixed.**

**Viscosity:** Viscosity is a measure of resistance of molecule layers moving relative to an adjacent layer. All fluid viscosity is affected by temperature. A multigrade lubricating oil tends to be less sensitive to temperature changes due to formulation. Lubricating oils are generally selected for use with viscosities appropriate for the expected operating temperature. The correct selection of a lubricating oil of correct viscosity is critical for optimum performance. Some effects of incorrect viscosity when the oil is too thick range from difficulty in starting, to increasing fuel consumption and reduced power output. When the oil is too thin, oil consumption is increased as well as wear from the metal to metal contact. This will also increase engine noise.

Low temperature viscosity specifications are identified by a "W" (winter). High temperature viscosity that meets the 100° C (212° F) requirements has no suffix. When lubricating oil meets both high and low temperature requirements they are classified as multi-viscosity or multigrade.



1. Check oil level daily.
2. Replace oil filter at every oil drain interval.
3. Cummins Engine Company, Inc. recommends the use of high quality, API (American Petroleum Institute) licensed CH-4 or CES20071, 15W-40, multiviscosity oil or premium oil.
4. The recommended oil drain interval is defined by the API oil performance classification and the engine duty cycle. Refer to the *Cummins Operation & Maintenance* Manual for complete details.

To change oil start with the motorhome at normal operating temperature. Park on a level surface and stop the engine. Remove the two crankcase drains plugs from both the deep and shallow portions of the oil pan to allow the oil to drain. Install the drain plugs back into the oil pan and tighten to 40 to 60 ft-lbs. Remove the oil filter.

**NOTE: It is recommended that the used oil filter be opened and the element examined for excessive wear particles; see the OEM Engine Manual for information on this procedure.**

Wipe the filter base sealing surface and ensure that the old gasket is removed. Apply clean engine oil to the gasket of the new filter and install the filter until the gasket contacts the filter base. Tighten the filter an additional  $\frac{3}{4}$  turn. Do not over-tighten. Remove the oil filler cap located at the rear of the engine. Fill the crankcase with the amount of oil determined by dipstick readings (about 20 quarts).

Allow time for the oil to drain into the sump and start the engine. Observe the engine for proper oil pressure. Run the engine at low idle for three minutes while observing engine and filter for leaks. Stop the engine and allow the oil to settle for five minutes. Check the level of the engine oil with the dipstick. Correct the level as necessary.

- The recommended oil drain interval is defined by the API oil performance classification and the engine duty cycle. Refer to the OEM Engine Manual for complete details.

---

### ***Cold Weather Engine Operation***

It is possible to operate diesel engines in extremely cold environments. The engine must be properly prepared and maintained. The appropriate lubricants, fuels and coolant **MUST** be used for the cold weather range for which the motorhome is being operated. In colder climates lubricants, coolant and even fuel can thicken. Be aware of oil viscosity, coolant to antifreeze mixture and fuel grade used. Fuels purchased in warmer climates may not flow properly in colder climates.

Cold weather operation is divided in two categories: Winter and Arctic.

**WINTER (32° to -25° F) (0° to -32° C):** Use a 50% antifreeze to 50% water coolant mixture, use multi-viscosity oil meeting Cummins specifications and fuel to have maximum cloud pour points 10° F (6° C) lower than the ambient temperature in which the motorhome operates.

**ARCTIC (-25° to -65° F) (-32° to -52° C):** Use a 60% antifreeze to 40% water coolant mixture. Use oil meeting Cummins specifications and fuel to have maximum cloud pour points 10° F (6° C) lower than the ambient temperature in which the motorhome operates.

**INFORMATION: There are numerous diesel fuel additives to help remove moisture, prevent microbe growth and prevent getting in cold weather. Before adding any type of fuel additive or extender, consult the Engine Manufacturer's Owner's Manual. More detailed information on Cold Weather Operations can also be found in the Engine Manufacturer's Owner's Manual.**

---

## **ENGINE SHUTDOWN**

General guidelines for shutting the engine down are fairly simplistic. Allow the engine to idle three to five minutes after a full load operation. This allows adequate cool down of pistons, cylinders, bearings and turbocharger components. Under normal driving conditions, exiting the highway is generally lighter engine operation and the need for the three to five minutes is not necessary. It is recommended to fill the fuel tank at the end of the day to help prevent condensation and drive out moist air. Do not fill the fuel tank to the top, as fuel will expand when warm and may overflow.

---

### ***Extended Engine Shutdown***

When the motorhome has been sitting for extended periods, 30 days or more, verify all the fluid levels are correct. Follow the normal starting procedures. If the oil pressure gauge does not register within 15 seconds, shut off the engine immediately to avoid damage. Consult the OEM Engine Manual for guidelines on troubleshooting low oil pressure, or contact a qualified service technician. If oil pressure is normal, allow the engine to idle for three to five minutes before operating under a load.

**TRANSMISSION - Shift Selector**

The Allison World transmission incorporates the World Transmission Electronic Control (WTEC) system. The system is comprised of five major components connected by a wiring harness: the electronic control unit (ECU), engine throttle position sensor, three speed sensors, remote shift selector (keypad) and the control module. The ECU processes information received from the throttle position sensor, speed sensor, pressure switch and shift selector to activate solenoids on the control module in the transmission. The solenoids control oncoming and off going clutch pressure to provide closed loop shift control. This is accomplished by matching transmission and engine RPM during a shift to establish a desired shift profile within the ECU.

The system is monitored for the first 30 seconds of each engine start. This is referred to as “autodetect.” Autodetect searches for presence of data inputs of transmission components. Autodetect enables the ECU functions and diagnostics to respond to items that are detected.

Another feature of the transmission is the ability to “learn” or “adapt.” The electronic control system optimizes shift quality by using “Adaptive Shifting.” A wide variety of varied shift conditions is required before optimizing shift quality. Generally, five typical shifts of a consistent shift type is needed to optimize shift quality.

The range selection is accomplished via the remote push button selector. The controls are R, N, D, arrow up, arrow down, MODE button and a digital display window. Under normal operation press the D button and the digital display shows the highest forward range attainable for shift selection in use. The digital display window will also indicate codes for abnormal conditions, and can even be a useful troubleshooting aid. When the ignition is turned ON, the display should be visible. This display indicates the presence of neutral start command. If the display indication is not visible, there is no power to the selector and the transmission will not allow the engine to start. This is an indicator of electrical problems with the engine batteries, ECU on shift selector keypad.

The window displays gear selection, various transmission modes, oil level and transmission fault codes.

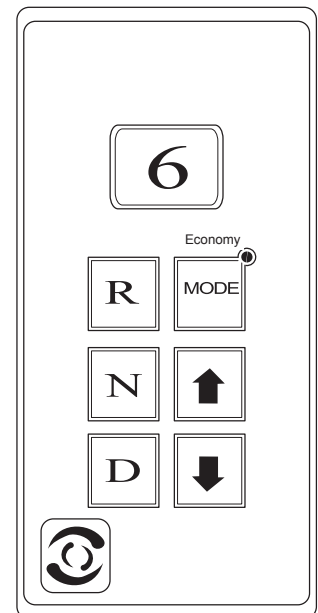

trans shifter w mode light.eps

**Keypad Functions:**

- Select the **REVERSE** gear by pressing **R**.
- Select **NEUTRAL** by pressing **N**. The area around the **N** button has a raised ridge so the driver can orient his hand to the push buttons by touch, without looking at the display.
- Select **DRIVE** range by pressing **D**. The highest forward gear appears in the display and the transmission will shift to first gear though 6 is displayed.
- The **UPSHIFT** and **DOWNSHIFT** arrow buttons are used to select a higher (if not in “**D**”) or lower (if not in “**1**”) forward range. These buttons are not functional in **NEUTRAL** or **REVERSE**. One press changes the gear range selected by one. If the button is held continuously, the selected range will continue to change up or down until the button is released or until the highest/lowest possible range of gears is selected.
- The **MODE** button enables a secondary shift point to be selected. This is commonly referred to as “Economy.” It is further used by the service technician to access diagnostic codes when troubleshooting. The diagnostic circuitry must be enabled to display.
- When the Auxiliary Braking device (Jacob or Exhaust brake) is used, the display changes to a default reading of **2**, **3** or **4**. This default is pre-selected at the factory and can only be reprogrammed by an authorized Allison Service Center. The transmission is not in second, third or fourth gear. This is only a reference for the transmission downshift points to optimize the engine braking effect.
- Engine temperature may rise when ascending long grades using full throttle. Towing a load will increase the demand on the engine. If this occurs manually shift the transmission down to the next lower gear and use less throttle. The engine will use less fuel and RPM should increase.

**NOTE: The transmission will not accept a manually selected gear change to occur if the gear selected is out of the specified operating range.**

**NOTE: The transmission will not shift into gear if the engine RPM is at or above 900. The display will flash “6” indicating the engine RPM is excessive. Select “N” and lower the engine RPM.**

---

**Transmission Check Light**

The electronic control system of the transmission is programmed to inform the operator of a problem with the transmission system and reacts automatically to protect the operator, motorhome and transmission. When the Electronic Control Unit (ECU) detects a **DO NOT SHIFT** (DNS) condition the ECU restricts shifting, turns on the **CHECK TRANS** light in the instrument panel and registers a fault code.

**NOTE:** For some problems, fault codes may be registered without the ECU activating the **CHECK TRANS** light. An Allison Transmission authorized service outlet should be consulted whenever there is a transmission related concern. They have the equipment to check diagnostic codes and correct problems which may arise.

Each time the engine is started the **CHECK TRANS** icon will light, then turn off after a few seconds. This momentary lighting is to indicate that the status light circuit is working properly. If the **CHECK TRANS** light does not illuminate during start up, or if the light remains on after start up, the transmission system should be checked immediately.

Continued illumination of the **CHECK TRANS** light during vehicle operation (other than start up) indicates that the ECU has signaled a diagnostic code. Illumination of the **CHECK TRANS** light is accompanied by a flashing display from the shift selector. The shift selector display will show actual range attained and the transmission will not respond to shift selector requests.

Indications from the shift selector are provided to inform the operator that the transmission is not performing as designed and is operating at reduced capabilities. Before turning the ignition off, the transmission may be operated for a short time in the selected range in order to "limp home" for service assistance. Service should be performed immediately in order to minimize potential damage to the transmission.

When the **CHECK TRANS** icon illuminates the keypad will not respond to command and the transmission generally will downshift to 4th gear. The torque converter will not "lock-up" and engine speed is automatically reduced. Direction changes (i.e. forward to reverse) will not be allowed. Locate a safe secure place to park the motorhome. If the engine is shut off, then engaged after a **CHECK TRANS** indication, the transmission remains in Neutral until the fault causing the **CHECK TRANS** light has been corrected.

**Diagnostic Codes:** The diagnostic codes are numerical representations of malfunctions in the transmission operations. Each code is a two digit main code and a two digit sub code. The codes, when detected, are logged in the ECU memory. These codes will fall in two classes: active and inactive. Active codes are codes currently effecting the ECU process. Inactive codes are retained but may not effect the ECU process. The diagnostic mode must be entered. A maximum of five codes, **D1** to **D5**, may be listed at one time. The highest priority code will be listed in **D1**. The **MODE** button will enable selection of sequential codes.

**To Enable Diagnostic Code Selection Display:**

- Stop the motorhome at a safe location.
- Apply the parking brake.
- Simultaneously press the **UP** and **DOWN** arrows twice to enter the stored codes. The first time the arrows are pressed will indicate the oil level display. Press the **UP** and **DOWN** arrows again.
- The codes will display one digit at a time.
- The mode button is pressed to scroll through the codes.
- Any code obtained should be noted and reported to an Allison Service Center for evaluation and possible repair.
- Inactive codes can be cleared by holding the **MODE** button for about three seconds. Some codes are self clearing while others will require service or ignition on/off cycles to clear.

---

**Periodic Inspections**

The Allison MH Series requires minimum maintenance. Careful attention to fluid level and connections for the electronic and hydraulic circuits is very important.

For easier inspection the transmission should be kept clean. Make periodic checks for loose bolts and leaking fluid lines. Check the condition of the electrical harnesses regularly. Check the engine cooling system occasionally for evidence of transmission fluid which would indicate a faulty oil cooler. Report abnormal conditions to an Allison dealer.

**Prevent Major Problems:** Help the WTEC III control system oversee the operation of the transmission. Minor problems can be kept from becoming major problems if an Allison Transmission distributor or dealer is notified when one of these conditions occur:

1. The shifting feels odd.
2. The transmission leaks fluid.
3. There are unusual transmission-related sounds (changes in sound caused by normal engine thermostatic fan cycling, while climbing a long grade with a heavy load, have been mistaken for transmission-related sounds).
4. The **CHECK TRANS** light comes on frequently.

**The Importance of Proper Fluid Levels:** Transmission fluid cools, lubricates and transmits hydraulic power. Proper fluid levels must be maintained at all times. If fluid level is too low, the converter and clutches do not receive an adequate supply of fluid. If fluid level is too high, the fluid can aerate. Aerated fluid can cause the transmission to shift erratically or overheat.

The MH Series oil level sensor (OLS) allows the operator to check the transmission fluid level from the keypad shift selector. Frequently check for the presence of oil level diagnostics in the transmission. If the OLS has not been detected, troubleshooting of the OLS circuit is required. This will have to be performed by an Allison Service Center. After the OLS circuit is repaired, ensure that reset of the “autodetect” or manual selection of the OLS function is enabled by using a Pro-Link transmission diagnostic center.

**Fluid Level Check with the Keypad:**

To Enter Oil Level Sense Mode:

- Park the motorhome on a level surface. Place the transmission in "N" and set parking brake.
- The transmission temperature must be at least 140° F./60° C, otherwise an error code will appear.
- The motorhome must be stationary and in **Neutral** for about two minutes to allow the fluid to settle in the sump.
- The engine must be idling lower than 800 RPM.
- Simultaneously press the **Up** and **Down** buttons once.

The transmission is now in **Oil Level Sense** mode. The display will indicate one character at a time. An "o" followed by "L" represents **oil level check** mode. One of the following will be indicated.

- "o K" represents the level is okay.
- "Lo" represents a low fluid level followed by a numeric indication of the number of quarts needed fill the sump.
- "HI" represents an overfull condition followed by a numeric indication of the number of quarts the sump is overfull.
- A countdown of flashing numbers indicate the fluid is still settling. When the fluid has stabilized in the sump the true level will be indicated.
- If an "o" "L" "-" followed by a number displays, the oil level sensor could not read the level due to one of conditions listed in the chart.

**Common Oil Level Fault Codes:**

Display	Cause of Code
o,L - 0,X	Setting time too short
o,L - 5,0	Engine speed (RPM) too low
o,L - 5,9	Engine speed (RPM) too high
o,L - 6,5	Neutral must be selected
o,L - 7,0	Sump fluid temperature too low
o,L - 7,9	Sump fluid temperature too high
o,L - 8,9	Output shaft rotation
o,L - 9,5	Sensor failure

**To Exit Oil Level Sense Mode:** Press **Neutral**, **Reverse** or **Drive**.

**NOTE:** Reading between the Oil Level Sensor and the dipstick may not agree because the OLS compensates for fluid temperatures.

**NOTE:** To correctly check the transmission fluid level using the dipstick, the transmission fluid must be at operating temperature. The oil level sensor method of checking the fluid level compensates for transmission fluid temperature between 60° C - 104° C (140° F - 220° F). Any temperature below 60° C (140° F), or above 104° C (220° F), will result in an error code.



## TRANSMISSION LUBRICATING FLUID

Transmission performance, reliability and durability are dependent on the type of lubricating fluids used. From the factory, the transmission has been filled with TranSynd™ synthetic transmission fluid. TranSynd™ synthetic transmission fluid extends the service intervals. A small tag has been attached to the dipstick identifying that the transmission is filled with TranSynd™ synthetic transmission fluid. The dipstick/oil fill is located in the rear curbside engine service compartment.

**Fluid and Internal Filters Change Interval:** Fluid and internal filters may require changing earlier depending on the severity of operating conditions. Fluid must also be changed whenever there is evidence of dirt or high temperature operation as indicated by discoloration, strong odor or fluid analysis. Local conditions, severity of operation or duty cycle will dictate more or less frequent service intervals.

**NOTE:** Refer to the Allison transmission owner's manual or contact an authorized Allison service center for change intervals.

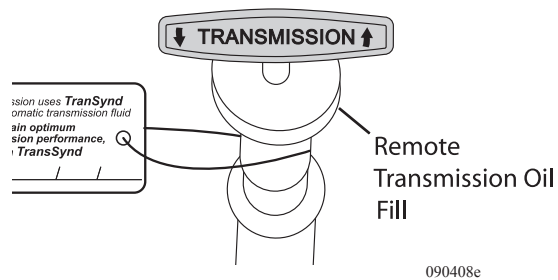
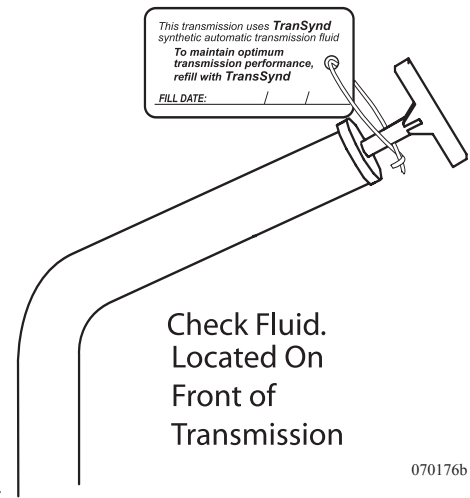

### Fluid Levels - Cold Check

**Cold Check - Manual Check Procedures:** The concept of a cold check is to determine adequate fluid level for safe operating until hot check can be performed.

#### To Check the Fluid When Cold:

- Park the motorhome on a level surface. Set the parking brake.
- With the engine operated at a low idle, put the transmission in **N** (Neutral).
- Chock the wheels to prevent the motorhome from moving.
- Allow the engine to run at idle (500-800 RPM) for one minute.
- Apply service brakes and shift to **D** (Drive), then to **N** (Neutral) and next to **R** (Reverse) to fill the system. Finally shift to **N** (Neutral) and release service brakes. Allow the engine to continue to run at idle (500 - 800 RPM).
- Remove the dipstick and wipe clean. Reinsert the dipstick fully into the tube and remove to check fluid level. Repeat this to verify reading if needed.
- Safe operating level is anywhere within the **COLD CHECK** band on the dipstick. The fluid level is sufficient enough to operate until a **HOT CHECK** can be performed.



- If the level is not within this band, add or drain the fluid as necessary to put the level to the middle of the **COLD CHECK** band.
- Perform the **HOT CHECK** at the first opportunity after reaching normal operating temperatures (160° - 200° F/71° - 93° C).

**CAUTION: Low or high fluid level can cause overheating and irregular shift patterns. These conditions can damage the transmission if not corrected.**

- Fluid level rises as temperature increases. Fluid must be hot to ensure an accurate check.
- Be sure fluid has reached normal operating temperature (160° - 200° F /71° - 93° C). If a transmission temperature gauge is not present, check the fluid level when the engine water temperature gauge has stabilized and the transmission has been operated under the load for at least one hour.
- Park the motorhome on a level surface and shift to **N** (Neutral). Apply the parking brake and allow the engine to idle (500 - 800 RPM).
- After wiping the dipstick clean, check the fluid level. Safe operating level is anywhere within the **HOT RUN** band on the dipstick.
- The width of the **HOT RUN** band is about one quart of fluid at normal temperature range.
- If the level is not within this band, add or drain the fluid as necessary to put the level within the **HOT RUN** band.
- Be sure that the fluid level checks are consistent. Check the level more than once. If the readings are not consistent, ensure that the transmission breather is clean and not clogged. If the readings are still not consistent, contact the nearest Allison distributor or dealer.

## COOLANT SYSTEM

The cooling system consists of a rear mounted radiator and in-line transmission cooler, as well as a charge air cooler that is mounted to the radiator. Steel tubes and radiator hoses allow engine coolant to flow between the radiator and the engine. The fan draws air from the out back of the engine compartment. These components working together ensure that all the chassis systems maintain proper operating temperatures as they are inner-related. A problem with one component may cause problems with an entirely different system.

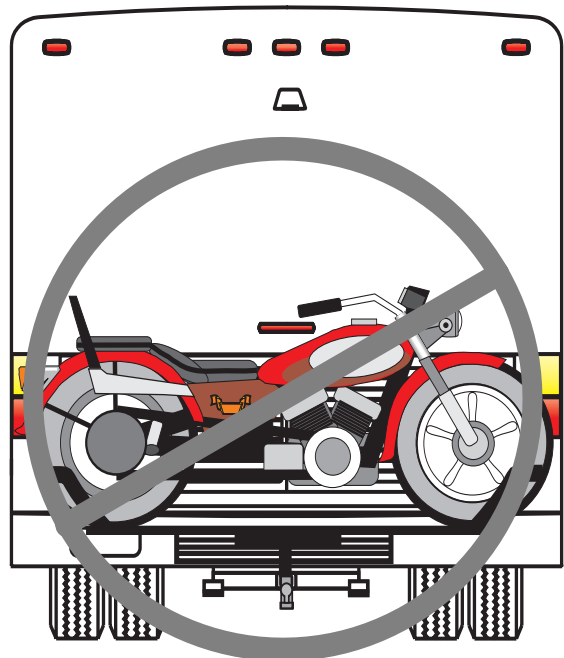

080208d

After the engine reaches proper temperature, the water regulator (thermostat) on the engine opens and allows coolant to flow from the engine, through the upper radiator hose and into the radiator. The coolant is cooled in the radiator and flows back to the engine through the lower radiator tube. A by-pass tube installed between the thermostat housing and lower radiator tube functions to supply coolant to the transmission cooler under certain conditions to ensure proper cooling.

The charge air cooler, which is mounted on the outboard side of the radiator, cools the intake air for the engine after it has passed through the turbocharger. This is necessary due to the heat generated as the intake air is pressurized, and subsequently heated, as it passes through the turbocharger.

With all the components working together to maintain the engine, transmission, and hydraulics operating at the proper temperatures proper maintenance of the cooling system is very important. One neglected component could result in cooling problems. Maintenance of the cooling system includes maintaining a proper coolant level with the correct mixture of coolant and additives, inspection of cooling system components, flushing the engine coolant system with approved cleaners, and ensuring that the exterior of the radiator and other external coolers are kept clean and free of debris.

Understand that adding straight water or antifreeze to the system creates an imbalance of the coolant mixture. While adding small amounts occasionally may not affect the mixture greatly, large amounts (1/2 gallon) or frequent "top-offs" will.

Three components necessary for the proper coolant mixture are clean water, glycol antifreeze (ethylene or propylene), and Supplemental Coolant Additives (SCA). The water in the coolant system serves as the "base." It is critical to use as pure of water as possible. Salts and other minerals in the water can solidify in the cooling system causing scaling and "clogging" of the radiator. Distilled or de-ionized water is recommended for use in the cooling system in order to avoid these problems.

Glycol antifreeze, usually in the form of ethylene glycol or propylene glycol, provides an increased boiling point of the coolant mixture, increased freeze protection, and helps prevent water pump cavitation (air bubbles in the coolant mixture that can result in wear of the engine). While the ratio of water and glycol can be adjusted to meet differing anti-boil and freeze protection, it is recommended that a mixture of 50% water and 50% glycol be used. This 50/50 mixture provides freeze protection to -34° Fahrenheit.

A minimum mixture of 30% glycol and 70% water is required in order to minimize water pump cavitation and corrosion protection.

Fully formulated antifreeze or coolant containing a precharge of Supplemental Coolant Additives (SCA) is recommended. The use of either will significantly simplify coolant system maintenance. The difference between a fully formatted antifreeze and a fully formatted coolant is the percentage of water. Both contain balance amounts of antifreeze, SCA, buffering compounds and a percentage of good clean quality water. The antifreeze of coolant must meet ethylene glycol or propylene glycol recommendations. A good clean quality water in a 50/50 ratio (40 to 60% working range) mixed with fully formatted antifreeze will provide protection from -34° F to 228° F. The 50/50 mix ratio must be premixed prior to being put in the system. Placing antifreeze and water in the cooling system is not recommended. Consult the *Cummins Operation & Maintenance Manual* for more details.

**NOTE: An over concentration of antifreeze, or the use of high silicate antifreeze, can cause damage to the coolant system and engine. Antifreeze is essential in every climate.**

**WARNING: Do not continue engine operation when engine temperature rises above 220° F. At 220° an engine warning light will illuminate and the engine will begin to de-rate in power output. Continued operation will result in engine damage.**

The coolant level and fluid freeze point should be checked with every oil change interval, at 15,000 miles, 500 hours or six months, whichever comes first. Also change the coolant filter (not on all engines) at the same interval unless SCA concentration is over three units. The coolant should be drained and flushed at 6,000 hours or two years of service, whichever comes first.

**Engine Coolant Reservoir:** A “see-through” plastic reservoir, similar to the familiar windshield washer jar, is connected to the radiator by a hose. As the motorhome is driven, coolant is heated and expands. A portion of fluid displaced by this expansion flows from the radiator into the reservoir tank. When the engine is stopped, the coolant cools and contracts. Displaced coolant is drawn back in the radiator by a vacuum. Thus, the radiator is kept filled with coolant to the desired level at all times resulting in increased cooling efficiency. The coolant level should be at or slightly above the appropriate mark on the reservoir tank when the system is cold.

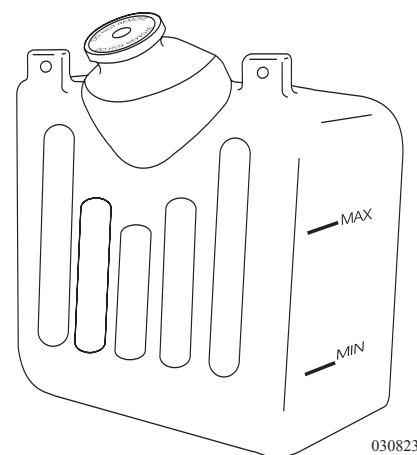

Located in the rear engine compartment.

**CAUTION: To avoid scalding hot steam or coolant from being released from the engine cooling system, never remove the reservoir cap while the engine is running or hot. Failure to follow this warning may result in damage to the engine’s cooling system and possibly cause severe personal injury.**

- Check the coolant level daily or when refueling.
- Drain and flush the coolant system every 60,000 miles or two years, and refill with a heavy-duty coolant (50/50 mix of water and antifreeze).
- If the coolant is below the **MIN** mark, the low coolant alarm will sound and the low coolant light will appear on the dash.
- The coolant level remains between the **MAX** and **MIN** level in the reservoir.

**INSPECT: Stop the motorhome and inspect the coolant level before continued operation.**

---

### ***Coolant Additive (SCA)***

Supplement coolant additives, or equivalent, are used to prevent cylinder liner pitting, corrosion and scale deposits in the cooling system.

Fully formulated products contain SCA and are required to protect the cooling system from fouling, solder blooming and general corrosion.

**CAUTION: Insufficient concentration of the coolant additives will result in cylinder liner pitting and engine failure. The SCA concentration must not fall below 1.2 units or exceed 3 units per gallon of cooling system capacity.**

**INFORMATION: For more information refer to the Cummins manual.**

#### **Routine Maintenance Recommendations:**

1. Check the SCA concentration level every 15,000 miles/6 months.
2. Drain and flush the system every 240,000 miles/2 years, and refill with a heavy-duty coolant (50/50 mix of water and antifreeze).
3. Always use antifreeze. In addition to freeze protection, antifreeze is essential for overheat and corrosion protection.
4. The supplemental coolant additive (SCA) is required.
5. Freeze point should be measured every 15,000 miles/6 months.

---

### ***Maintenance Procedures***

When performing maintenance, it is also necessary to **inspect** other components of the cooling system.

Have an **inspection** performed of the surge tank cap seal and have the cap pressure tested, and also replace the thermostat, gasket and seal. The charge air cooler and radiator also requires an **inspection** for cracks, broken welds, secure mounting, and general cleanliness.

It may be necessary to clean the radiator and external coolers more often under certain conditions. Leaves, twigs, road debris and other contaminants can block the radiator and cooler fins resulting in reduced cooling system performance. Blockage can vary depending on road conditions, climate, and regional conditions. Check the radiator and external coolers weekly for blockage and clean as required. To clean the radiator and external coolers, compressed air is recommended. In the event that road grime, oil, or inadequate cleaning with compressed air is encountered, a high pressure washer and degreaser may be used with caution, as excessive pressure can bend the radiator fins.

Please refer to the Cummins OEM Manual for detailed information regarding the 24 month/60,000 mile maintenance interval. This service includes draining the engine coolant, flushing/cleaning the cooling system, **inspecting** the water pump standpipe and replacing the thermostat, gasket and seal.

**Coolant Hoses:** Rotten, swollen and worn hoses, as well as loose connections, are frequent causes of coolant system problems. Overheating can be caused by a collapsed hose or a clog caused by rubber shedding from a rotten hose. Replace hoses found to be cracked, swollen or damaged. Connections should be inspected periodically and hose clamps tightened.

**Every 12 months - Inspect** all hoses, clamps, and fittings for leaks due to cracking, softness, and loose clamps/fittings. Look for signs of fluid leaks, damaged end fittings, ballooning, chafed, kinked, or crushed hoses, and loose clamps and fittings. Correct deficiencies.

**Coolant Overheated:** If the engine is overheated, never pour cold coolant into a hot engine. The sudden change in temperature may crack the cylinder head or block. If the engine is hot, fill slowly to prevent rapid cooling and distortion of engine castings.

**Coolant Changing: 24 months/60,000 miles - Inspect** and clean the cooling system and charge air systems to promote system cleanliness and to enhance engine cooling. Stop the engine and allow it to cool. Remove the cap from the surge tank and place a large container beneath the drain valve on the radiator. Open the drain valve and allow the cooling system to drain. With the drain valve open, flush the cooling system with clean water to remove debris. Dispose of the old coolant mixture appropriately. Close the drain valve and fill the cooling system with a mixture of clean water and sodium carbonate. One pound of sodium carbonate is needed for every six gallons of water. Operate the engine for five minutes at temperature above 176 ° F. Stop the engine and allow the system to cool. Open the radiator drain valve to allow the system to drain. Fill the system with high quality water. Again, operate the engine for five minutes at temperature above 176 ° F. Flush the system with clean water until the draining water is clear. Allow draining completely. **Inspect** the water pump standpipe for blockage.

Replace the thermostat. Loosen the hose clamps and remove the hose assembly from the radiator to thermostat housing assembly. Remove the thermostat housing assembly from the cylinder head. Remove the thermostat and gasket from the housing, along with the seal in the housing. Install the new thermostat, seal and gasket into the housing. Re-install the thermostat housing and connect the hose assembly. Tighten the hose clamps. Ensure that the drain valve for the radiator is closed. Fill the cooling system with the recommended coolant / water / coolant additive mixture. Start the engine with the surge tank cap removed and allow the coolant to warm and the thermostat to open. Add coolant mixture until the coolant level in the surge tank is between MIN and MAX. Replace the surge tank cap. Allow the engine to warm to operating temperature while observing for coolant leaks. Stop the engine.

**Inspect** the radiator core and CAC for dirt and debris build-up. Wash accumulations using high-pressure water, being careful not to damage the fins from excessive pressure. Grease or oil build-up should first be treated with a non-caustic degreaser to ensure a thorough cleaning.

**Coolant System - Thawing:** If the coolant system becomes frozen solid, place the motorhome in a warm area until completely thawed. At this point the motorhome must be towed. If the engine is operated when the cooling system is frozen it will result in engine overheating due to insufficient coolant circulation. Once thawed, check engine, radiator and related components for damage caused by expansion of frozen coolant.

## CHARGE AIR COOLER

The diesel engine uses compression to ignite the fuel/air charge. To increase compression inside the combustion chamber (resulting in increased power output) a turbocharger is added to the engine. The turbocharger is a paired housing assembly with impellers inside each housing connected by a common shaft. One impeller is propelled by the engine exhaust, which drives the other impeller. The function of the other impeller is to increase compression inside the combustion chamber by forcing air into the intake manifold. The intake air charge is heated two different ways: through convection by the exhaust gases driving the turbocharger, and any time air is compressed heat is produced. This has a negative effect inside the combustion chamber resulting in lost power potential. Therefore, a Charge Air Cooler (CAC) is installed to cool the intake air before it enters the engine. The CAC may be mounted to either the top or side of the radiator.

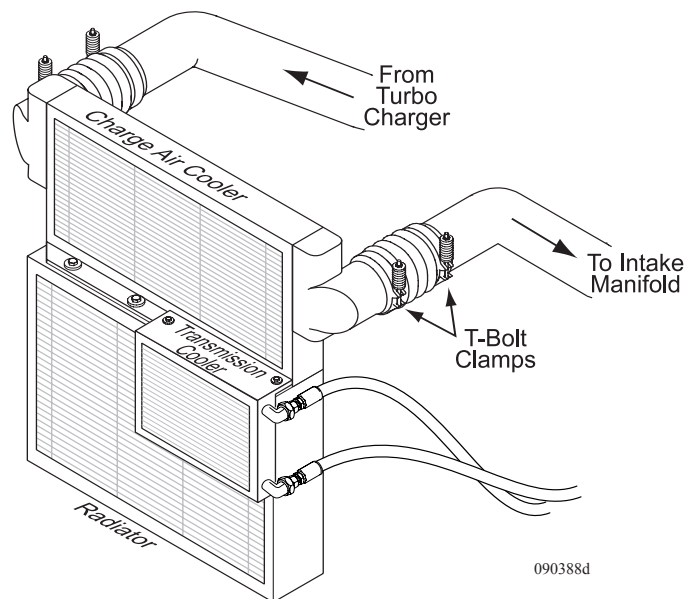



The CAC performs the same function as a radiator, cooling air instead of liquid. Ambient air passing through the CAC will cool the engine's intake air charge.

After leaving the turbocharger, intake air is compressed and heated to about 300° to 375° F., depending on the engine load and throttle position. Before the air enters the intake manifold, the CAC cools the intake air temperature to the engine manufacturer's specifications. Lower intake air temperatures reduce exhaust emissions, improve fuel economy and increase horsepower. The CAC will continually expand and contract up to ¼" as throttle increases and decreases.

Visually **inspect** the charge air cooler, every six months, for dirt and debris that may be blocking the fins. If the motorhome develops an oil leak, there is a possibility that the oil will coat the fins of the CAC. Dust will adhere to the oil film and eventually clog the fins greatly reducing cooling efficiency. When the oil leak is repaired, the CAC must be thoroughly cleaned.

Spraying degreaser on the charge air cooler, as well as using a steam cleaner, will not damage the CAC. However, pressure washer and steam cleaner nozzles placed too close to the CAC can bend the fins. The recommended cleaning procedure for the CAC, and the radiator, is to use a bucket of mild soap and water. Carefully wash with a bristle brush then rinse using a garden hose, with minimum water pressure, standing back a distance to avoid bending the fins.

---

## FUEL SYSTEM

The fuel tank, fuel lines, fuel/water separator, secondary fuel filter, fuel transfer pump, and fuel injectors are primary components of the fuel system. When the fuel transfer pump is operating, fuel is drawn from the fuel tank through the fuel supply hose to the primary water/separator. Most contaminants that may be present in the fuel are removed at this point. The fuel then flows to the secondary filter that removes any remaining contamination in the fuel down to five microns. From the filter, the fuel flows to the injectors, where the ECM controls injection timing and the amount of fuel delivered to the cylinder through the use of an electric solenoid on the injector. Fuel that is not used is returned to the fuel tank.

The fuel passes through the fuel transfer pump, which is a fixed clearance gear transfer pump, and through passages in the electronic control module (ECM) in order to provide cooling for the electronics.

Prevention of problems associated with the fuel system and performance of the vehicle begins with the quality and cleanliness of the fuel used. Fuel contaminated with water, dirt, and even algae can quickly clog fuel filters and cause problems with the fuel system.

Try to obtain fuel from large fueling stations, such as truck stops, that do a large amount of business and the supply of fuel is replenished often.

Always keep the fuel tank full whenever possible, this helps prevent water condensation from forming inside the fuel tank. Condensation can cause problems in the fuel system not only with the filters, but can also eventually cause corrosion of the fuel tank. Always store the motorhome with a full tank of fuel.

**Fuel Requirements:** Low sulfur #2 diesel fuel or #1 and #2 commercial blend diesel fuels are the most common commercially available and recommended for use. The use of #2 diesel fuel will result in optimum engine performance. Try to obtain fuel from sources that are serviced often such as large truck service facilities. The fuel supply is fresh and the possibility of introducing contaminants or water into the fuel system is reduced.

If driving in cold climates or extreme cold climates, consider winter blend diesel fuel. The winter blend diesel fuel contains a blend of additives to prevent it from forming wax crystals or gelling, which can solidify and plug fuel filters, causing problems starting and operating. It is important to consider fuel purchased in one climate may not perform in another climate.

Fuel additives are the responsibility of the owner or operator. Winter blend diesel is widely available in the northern United States and Canada during colder months. It is important not to empty the engine of fuel. The fuel system on the engine is sensitive to air.

**WARNING: Do not mix gasoline with diesel fuel. This mixture can cause an explosion.**

**NOTE: Due to the precise tolerances of diesel injection systems, it is extremely important that fuel be kept clean and free of dirt or water. Dirt or water in the system can cause severe damage to both the fuel pump and the fuel injector. Fuel additives for lubricity are not recommended. There are numerous diesel fuel additives to help remove moisture from fuel, prevent microbe growth and to prevent freeze-up during cold weather. Before adding any type of fuel additive or extender, consult the Manufacturer's Owner's Manual.**

**Fuel Tank:** The diesel fuel tank is made of 13-gauge steel. The total capacity is 100 gallons. The engine pick-up tube is cut at a 45-degree angle to allow optimum flow to the engine.

**NOTE: If the motorhome has been stored for any length of time, check the vent for blockage. It is not uncommon for insects to plug the vent tube. If the tank appears to be pressurized the vent tube may be blocked. To inspect the vent tube check on the curbside of the fuel tank, near the bottom. Always store the motorhome with a full fuel tank.**

## Fuel Sender

The "Centroid" fuel sender has no moving parts and works by measuring capacitance (electrical property) between its inner and outer tubes in the tank. The more fuel between the tubes, the higher the reading. Electronics in the "hockey-puck" head of the sender convert the capacitance to current to drive the fuel gauge.

**The "Centroid" sender has four connections:**

- **Positive (POS) and Negative (NEG):** Battery voltage to run the electronics in the sender head.
- **SEND:** Connects to the SEND terminal of the gauge on the dash.

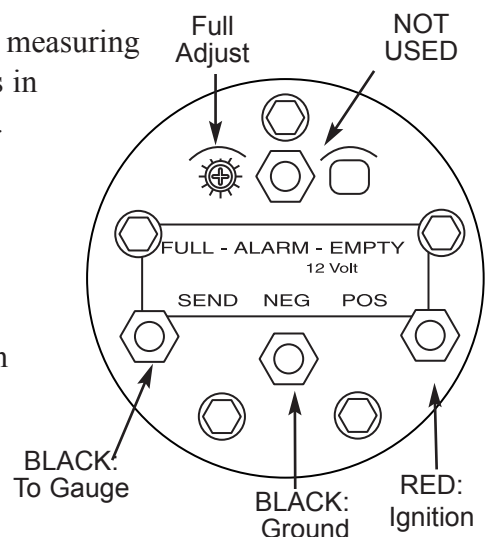

Fuel Sending Unit.

090318



- **ALARM:** Makes a connection internally to the negative (NEG) terminal when the low fuel alarm level is reached (when the fuel gauge is reading about 1/8 tank). This turns on the low fuel indicator light on the dash and is not adjustable.

**Adjustments:**

**The "Centroid" sender has two adjustments:**

- **EMPTY:** Adjusts for length of sender. It has been set at the factory, covered with a sealant and should not be changed.
- **Full Adjustment (FULL):** The full adjustment can be used to correct for slight differences between fuel meters. During installation, it has been calibrated for the meter and should not need readjustment.

The correct adjustment technique, with a full tank of fuel, is to start with the full adjustment screw completely clockwise. This should cause the reading to be above full. Adjust slowly, rotate counterclockwise, until the full mark on the gauge is reached. The intent is to always adjust downscale rather than upscale.

**Troubleshooting:**

- A. Electronic Output:** The sender has a transistorized output to prevent an ohmmeter from getting a correct reading of its output resistance.
- B. Fuel Only:** The sender will not work correctly in conducting fluids such as water (it will read above full all the time in water). One possibility is that when there is a constant above-full reading there may be water in the bottom of the fuel tank.
- C. Contact Centroid:** Probably 90% of the return Centroid tests work okay on the bench. If you have incorrect readings contact **Centroid (telephone: 800-423-3574, or preferably, fax: 386-423-3709)** with the symptoms. A short, "fill in the blanks" troubleshooting test is provided to test the sender. It is easier to find the problem that way than after the sender has been removed from the system, since the problem is not necessarily with the sender.

## Fuel Filters

The fuel filters are located in the roadside compartment behind the rear wheel. The primary fuel filter has a drain located at the bottom of the filter. Water (by weight) is heavier than fuel and will collect in the sediment bowl. Water can accumulate in the fuel from condensation in the fuel tank or contamination upon refueling. If water passes through the filters it can cause engine misfire and damage fuel injectors. The primary filter should be drained before each trip.

**NOTE: Replace both primary and secondary filters every 20,000 miles or one year.**

### To Drain the Primary Filter:

- Shut off the engine.
- Turn the valve counterclockwise about 1½ to 2 turns until draining occurs.
- Drain the filter of water and sediment until clear fuel is visible.
- Turn the valve clockwise to close the drain valve.
- Depending on the amount of contamination it may be necessary to replace the filters at the first opportunity.

In the event the engine runs out of fuel, the lift pump on the fuel pump will run for about one minute with the ignition on. The ignition may need to be turned on and off several times before attempting a start. If unable to restart, contact the nearest **Cummins Center** or phone **1-800-343-7357** for Cummins Customer Assistance Center.

## Fuel Line & Hoses

Make a visual check for fuel leaks at all engine-mounted fuel lines and connections and at the fuel tank pick-up and return lines. Leaks in this area may best be detected by checking for accumulation of fuel under the tank. Engine performance and auxiliary equipment is dependent upon the ability of flexible hoses to transfer lubricating oil, air, coolant and fuel oil. Diligent maintenance of hoses is an important step in ensuring efficient, economical and safe operation of engine and related equipment.

**INSPECT: Check hoses daily as part of the pre-start-up inspection. Examine hoses for leaks. Check all fittings, clamps and ties carefully. Make sure that the hoses are not touching shafts, couplings and heated surfaces, including exhaust manifolds, sharp edges or other obvious hazardous areas. Since all machinery vibrates and moves to a certain extent, clamps and ties can fatigue with age. To ensure continued proper support, inspect fasteners frequently and tighten or replace them as necessary.**

Engine oil levels above the dipstick full mark, or a decrease in lube oil consumption, may indicate internal fuel leaks into the crankcase. Check oil level frequently for fuel contamination.

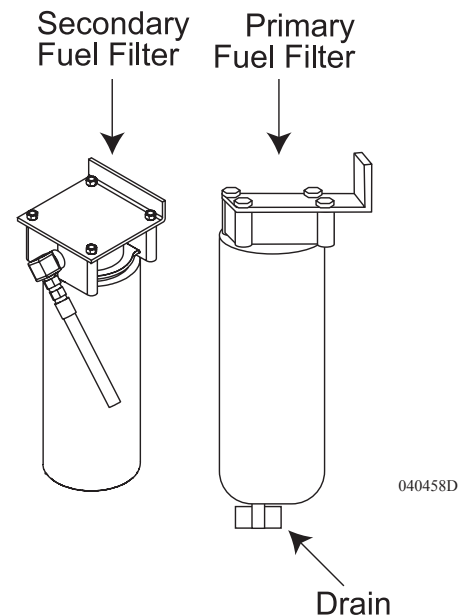

## HYDRAULIC SYSTEM

On a walk around and pre-check of the motorhome, look for oil leaks under the coach and around hose fittings. If a hose connection appears to be leaking, clean the filter and the surrounding area. If seepage continues, have the problem corrected to prevent an untimely failure.

### Hydraulic Reservoir

The power steering reservoir with internal filter is located in rear compartment. The hydraulic filter assembly, located inside the reservoir, is rated at ten micron\*. The reservoir is filled with 15W-40 motor oil from the factory.

**Filter assembly: Nelson 91085G**  
**Element number: 84365A (ten micron\*)**

The primary function of the power steering reservoir is to keep the steering system free of contamination and to dissipate excessive heat that builds during extreme operating conditions.

Check the oil level in the reservoir every 6,000 miles or three months. The oil dipstick fill is located on top of the reservoir in the rear compartment. The oil level should be kept between the full and add marks on the dipstick. If adding of fluid is required, use only 15W-40 motor oil.

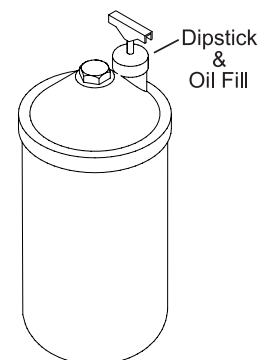

090391

### Hydraulic Pump

#### Checking the Fluid Level:

1. Start the engine and allow it to reach normal operating temperature.
2. While the engine is at idle, turn the steering wheel left and right several times.
3. Shut the engine off.
4. The easy grip handle is rotated counterclockwise to remove the dipstick.
5. Check the fluid level on the "HOT" side of the dipstick. It should be in the area of "HOT" on the dipstick. This is the normal range for the dipstick. Do not exceed the full mark.
6. If the fluid level is low, add fluid in small amounts, continuously checking the level until the "FULL" mark is reached.
7. Insert the easy grip handle back in the reservoir and rotate clockwise until securely fastened.

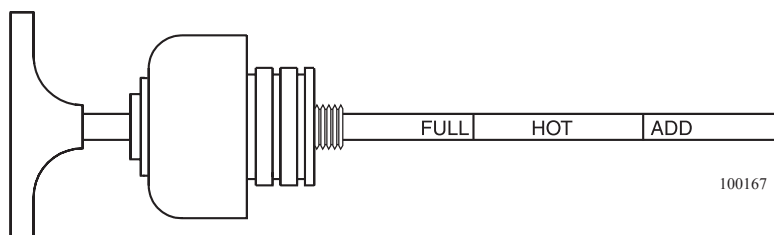

100167

## Hydraulic Filter

Change the hydraulic oil filter every 15,000 miles, or once a year, for cellulose element.

### Changing the hydraulic oil filter:

1. Using a 15/16 inch wrench, loosen the center cover bolt.
2. Remove the bolt and cover plate to access the spring and filter.
3. Remove the spring and washer to remove the filter assembly.
4. After replacing the filter assembly, reverse the process to re-assemble the reservoir.
5. When attaching the cover plate in the rubber cover seal, check for any damage.

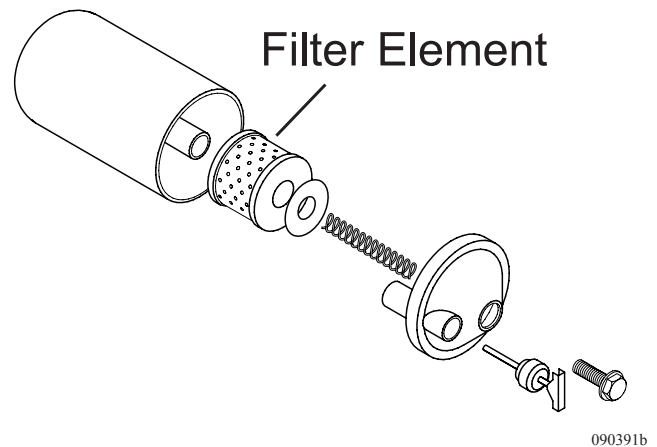

## AIR INTAKE & CHARGE AIR SYSTEM

The air intake and charge air system supply the engine with clean air for proper combustion and performance. Air entering the system is cleaned through a replaceable filter element and monitored with an air filter restriction indicator.

The airflow through the air filter is passed through the engine turbocharger, which pressurizes and heats the air. The heated pressurized air then passes through the charge air cooler, where the air is cooled before entering the engine intake manifold.

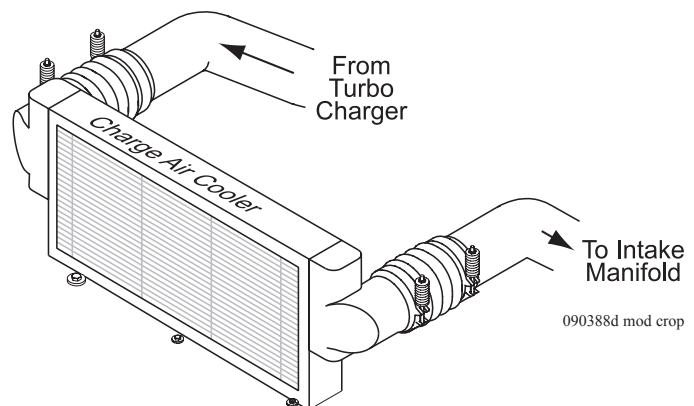

The air entering the engine must be clean as possible, as contaminated air can cause destruction of major engine components. Even small amounts of contaminants can do major damage to an engine.

**INSPECT: The air intake system on a weekly basis, looking for damage, clogged fins, loose connections, and wear to the air ducting, clamps, and filter housing. Check to ensure that the ducting is not rubbing or wearing on other components and that all components are securely in place. Have any problems investigated and corrected as soon as possible in order to prevent engine damage.**

The air filter restriction indicator relays the amount of restriction present in the air intake system and should be inspected before each trip. If the **yellow** indicator approaches the **red** (top) area of the air restriction indicator, it is signaling that the air filter is beginning to become excessively dirty.

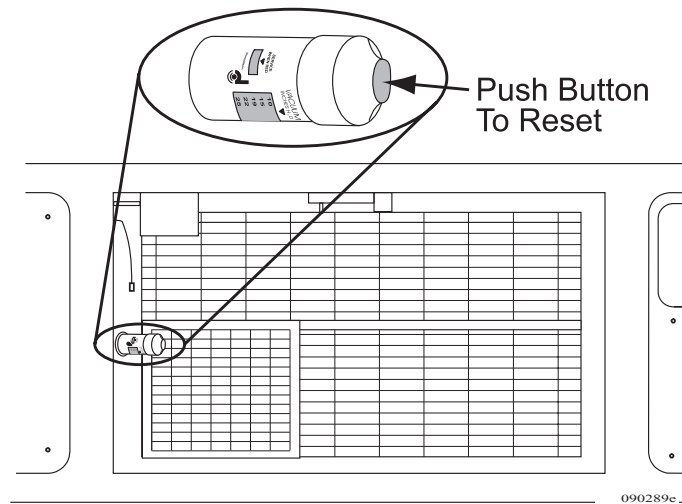

### **Changing Air Filter**

To replace air cleaner remove screws and cover from air cleaner body. Remove air cleaner cartridge and discard. Install new air cleaner cartridge and secure with cover and screws.

**WARNING:** Do not start the engine with the air cleaner removed and do not remove it while the engine is running.

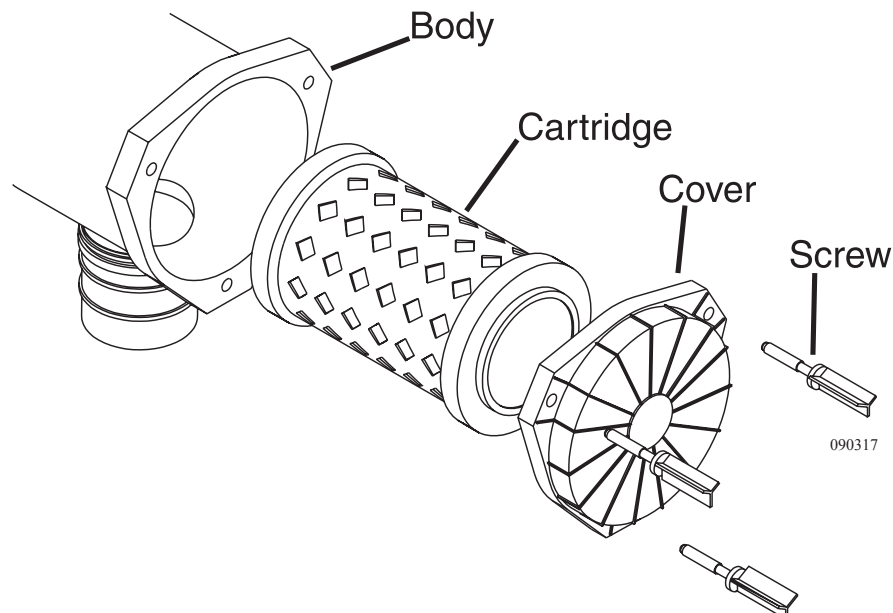

# LUBRICATION CHARTS

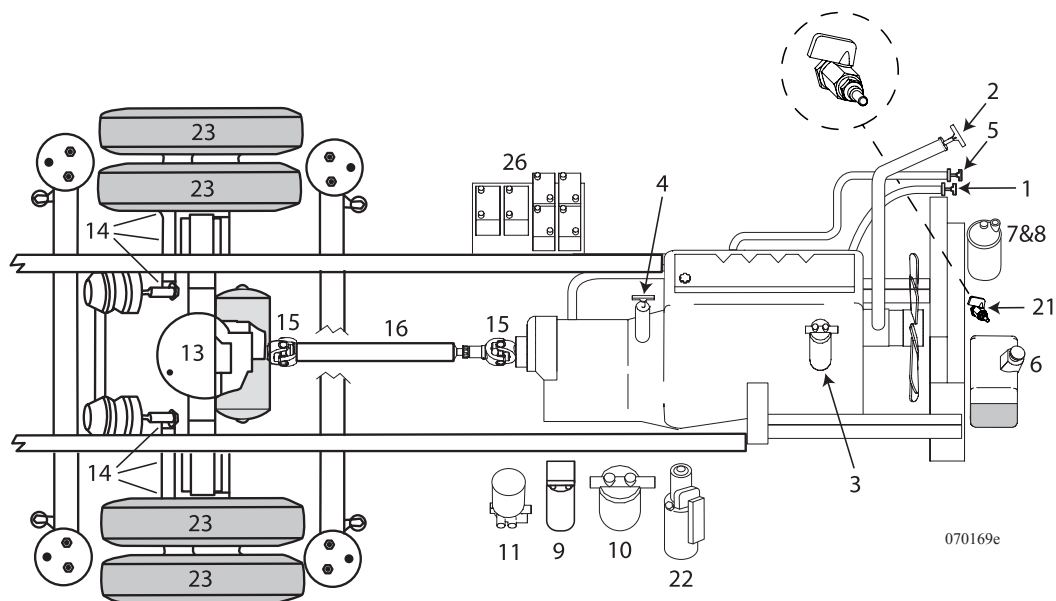

Component:	Action:	When:	Code-Refer to Chart:
1. Engine Oil Dipstick	Keep to Full Mark	Before Each Trip + Daily Enroute	EO
2. Engine Oil Fill	Change Oil	20,000 or Annually	EO
3. Engine Oil Filter	Replace	At Oil Change	OEM
4. Transmission Check/Fill	Keep to Full Mark	Refer to OEM Manual	TS
5. Transmission Remote Fill	Keep to Full Mark	Refer to OEM Manual	TS
6. Engine Coolant	Replace	Refer to OEM Manual	AF
7. Hydraulic Fluid Reservoir	Keep to Full Mark	Monthly	E02
8. Hydraulic Filter	Replace	15,000 or Annually	E02
9. Filter Fuel/Water Separator (Primary)	Replace	20,000 or Annually	FF
10. Filter Fuel (Secondary)	Replace	20,000 or Annually	FF
11. Air Dryer Filter	Replace	2 -3 Years	-
12. Wheel Bearings	Re-pack	30,000 or Annually	HT
13. Rear Differential	To Filler Plug	250,000 or 3 Years	MP
14. Slack Adjusters/S-Cams	Grease-3 Fittings	10,000 or 3 Months	CBL
15. Drive Shaft Universal Joints	Grease-2 Fittings	10,000 or Annually	CL
16. Drive Shaft Slip Yoke	Grease-1 Fitting	10,000 or Annually	CL
17. Drag Link	Grease-1 Fitting	5,000 or 6 Months	CL
18. Tie Rod End	Grease-2 Fittings	5,000 or 6 Months	CL
19. Spindles/Kingpins	Grease-2 Fittings ea.	5,000 or 6 Months	CL
20. Steering Shaft	Grease-3 Fittings	30,000 or Annually	CL-4
21. Air Tank Drains	Drains	Monthly	-
22. RVA Reservoir	Keep to Full Mark	6,000 or 3 Months	TF
23. Tire Pressure	Check	Before Each Trip + Daily Enroute	-
24. Steering Box	Grease-1 Fitting	Twice a Year	CL
25. Generator	Refer to Service Manual	Refer to OEM Manual	OEM
26. Batteries	Inspect	Bi-Monthly	DW

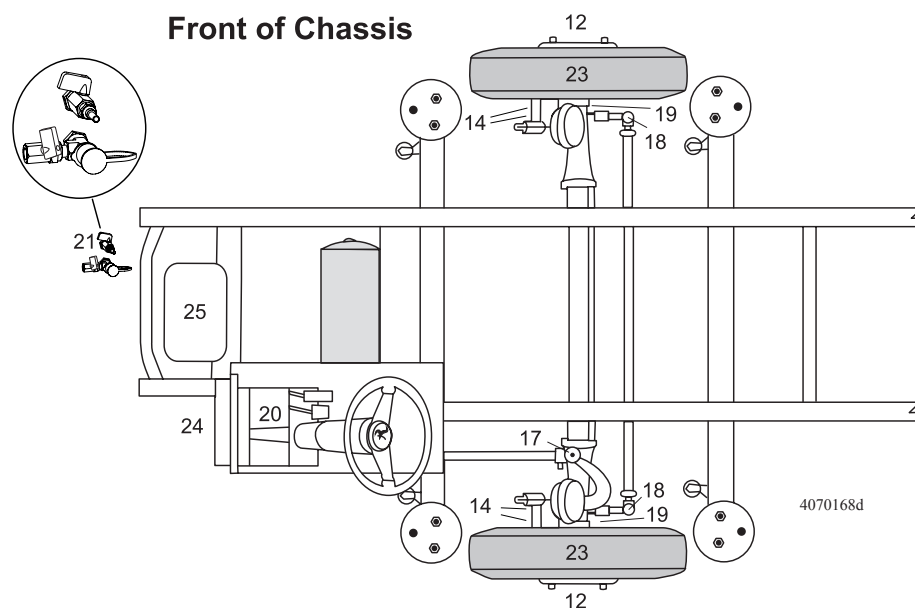

<b>Lubrication Code Chart</b>	
CL-4	U-Joints located inside the motorhome under the steering cover
EO	Engine oil as recommended by engine manufacturer
OEM	Refer to Equipment Manufacturer's Manual
MP	API GL-5 or MT-1 type gear lubricant - Penzoil Gear Plus SUPER-ew 75w-90, Synthetic
GO	EP-SAE 90 Gear oil
CL	Chassis lubricant should be high quality non-corrosive multi-purpose lithium soap pressure gun lubricant that is water resistant and designed to withstand extremely high operating temperature
P	Petroleum jelly or commercial battery terminal corrosion inhibitor
AF	Antifreeze as recommended by the engine manufacture
TF	Transmission fluid. Use <i>Dexron III</i> ® transmission fluid only
FF	Fuel filter
BF	Dot-3 Brake Fluid
TS	TranSynd™ synthetic transmission fluid (identified by tag on dipstick)
CBL	Clay-based lubricant
DW	Distilled water
HT	High temperature bearing grease

**NOTE:** It is important to remember the generator lubrication interval is based on hours of usage. Consult the OEM for the generator service interval.

## SPECIFICATIONS DIMENSIONS CHART

2005 Knight Specifications	34SBD	36PDD	36PRT	37PBD	38PST	38PDQ	40PLQ	40DST
<b>Weights</b>								
Gross Vehicle Weight Rating	33,000 lb.	33,000 lb.	33,000 lb.	33,000 lb.	33,000 lb.	33,000 lb.	33,000 lb.	33,000 lb.
Gross Combined Weight Rating	43,000lb.	43,000lb.	43,000lb.	43,000lb.	43,000lb.	43,000lb.	43,000lb.	43,000lb.
Front Gross Axle Weight Rating	13,000lb.	13,000lb.	13,000lb.	13,000lb.	13,000lb.	13,000lb.	13,000lb.	13,000lb.
Rear Gross Axle Weight Rating	20,000 lb.	20,000 lb.	20,000 lb.	20,000 lb.	20,000 lb.	20,000 lb.	20,000 lb.	20,000 lb.
<b>Measurements</b>								
Wheelbase	196"	216"	216"	228"	242"	242"	256"	256"
Overall Length	34'-11"	37' 1"	37' 1"	37' 10"	39' 3"	39' 3"	40'-5"	40'-5"
Overall Height with A/C (Increase 3" Plus change to 8-Bag Chassis)	12'-3"	12'-3"	12'-3"	12'-3"	12'-3"	12'-3"	12'-3"	12'-3"
Interior Height (Increase 3")	6' 9"	6' 9"	6' 9"	6' 9"	6' 9"	6' 9"	6' 9"	6' 9"
Interior Width	94.5"	94.5"	94.5"	94.5"	94.5"	94.5"	94.5"	94.5"
Exterior Width	100.5"	100.5"	100.5"	100.5"	100.5"	100.5"	100.5"	100.5"
<b>Tank Capacities</b>								
Water Heater	10 gal.	10 gal.	10 gal.	10 gal.	10 gal.	10 gal.	10 gal.	10 gal.
Grey Tank	60 gal.	60 gal.	60 gal.	60 gal.	60 gal.	60 gal.	60 gal.	60 gal.
Black Tank	40 gal.	40 gal.	40 gal.	40 gal.	40 gal.	40 gal.	40 gal.	40 gal.
Fresh Tank	100gal	100gal	100gal	100gal	100gal	100gal	100gal	100gal
LP Tank *	40 gal.	40 gal.	40 gal.	40 gal.	40 gal.	40 gal.	40 gal.	40 gal.
Fuel Tank	100 gal.	100 gal.	100 gal.	100 gal.	100 gal.	100 gal.	100 gal.	100 gal.
* Actual filled LP capacity is 80% of listing due to safety shut off required on tank.								

**NOTE:** This Chart reflects product specification available at the time of printing. Therefore any floor plans thereafter may not be reflected in the chart. All other information contained throughout the manual will still apply.

**NOTE:** All tank capacities are estimated based upon calculations provided by the tank manufacturers and represent approximate capacities. The actual "usable capacity may be greater or less then the estimated capacities based upon fabrication and installation of the tanks.

CHASSIS LIQUID CAPACITIES	ISC 330	
	QUARTS	GALLONS
Engine Oil	24 quarts	6.0 gallons
Transmission (initial fill)	22 quarts	5.5 gallons
Transmission (service fill)	19 quarts	4.75 gallons
Coolant	39 quarts	9.75 gallons
Rear Differential	16 quarts (approximately)	4.0 gallons (approximately)
A/C Refrigerant	4 pounds of R134	4 pound of R134



ENGINE SPECIFICATIONS - CUMMINS ENGINE ISC 330	
Engine Size / Cummins	8.3 Liter
Allison Transmission	MH 3000
Torque (lbs - ft. Max. Net at 1,400 RPM)	950
Cubic Inch Displacement	540.5
Alternator / Leece Neville	160 amp
Rear Axle Ratio	4.30:1
Tire Size / Goodyear	275/70R22.5

8.0 Kw

**C.5 LP Generator Service Information**  
 Refer to Operator's manual for maintenance specifications and adjustments.

Oil Level	Check Daily
Air Filter	Clean at 150 hours* & replace at 450*.
Oil and Oil Filter	Change at 150 hours* or annually (whichever comes first).

\*Perform more often in dusty conditions.

Replacement Information	
Air Filter	140-3116
Oil Filter	122-0836
Oil Capacity	2 quarts with oil filter

Ambient Temperature	SAE Viscosity
32° F and higher	30
10° F to 100° F	15W-40
0° F to 80° F	10W-30
-20° F to 50° F	5W-30

When service or parts are needed you Onan Distributor is in the Yellow Pages under "Generator-Electric".  
 In USA and Canada call 1-800-888-ONAN.

**SERVICE INFORMATION**

Refer to operator's manual for maintenance specifications and adjustments.

Air Cleaner	—	140-2897
Oil Filter	—	185-5409
Fuel Filter	—	149-2513
Oil Capacity	—	3 Qts w/oil filter
API Designation	—	CE

Temp	SAE Viscosity
5° - 120°F	15W-40
(-13°F) - 68°F	10W-30
(-40°F) - 68°F	5W-30

If service/parts are needed the Onan distributor can be located in the yellow pages under Generators-Electric.

In the USA or Canada call 1-800-888-Onan  
 DC Fuss & Radiator Cap Under Cover.



Diesel Generator Label

020159k

**NOTE:** Filter and belt numbers were correct at the time of printing. Verify the numbers at time of removal. The manufacturer will not be responsible for incorrect filter or belt usage. Please refer to the engine manufacturer's operating instructions for specific maintenance information.

**CHART - FILTERS & BELTS**

ISC FILTERS AND BELTS	MANUFACTURER	NUMBER
A/C Belt	Dayco	15465
Air Filter	Donaldson	P533930
Alternator Belt	Dayco	3911581
Fuel Filter Primary	Fleetguard	FS 1242
Fuel Filter Secondary	Fleetguard	FS 1022
Oil Filter	Fleetguard	LF3000
Coolant Filter	Nelson	83213D
Transmission Filter	Allison	Internal Filters

## BATTERY SPECIFICATION CHART

Application	Ah (20hr)	CCA†	RC (25A@80° F) minutes
12 Volt Chassis* Group 31p-LHD (2 each)		750	180x2=360
6 Volt Domestic** U2200 (4 each)	450		75 Amp@80° F= 230 min.

\*Batteries connected in parallel.

\*\*Battery connections are made in a Series/Parallel connection.

†CCA Ratings are at 0° F. These are the minimum requirements.

Battery State of Charge vs. Voltage/Specific Gravity			
Voltage	Specific Gravity	State of Charge	Depth of Charge
12.66	1.265	100%	0%
12.45	1.225	75%	25%
12.25	1.19	50%	50%
12.05	1.145	25%	75%
11.9	1.1	0%	100%

Voltage Reading: Battery fully charged at rest for one hour.

Cummins Engine Cold Cranking Amps Requirements			
ISC	1500	CCA	12 Volts
CCA Ratings are at 0° F. These are the minimum requirements.			

## METRIC/U.S. CONVERSION CHART

U.S. Customary to Metric			Metric to U.S. Customary			
Measurement	Multiplied By	Equals/Measurement	Multiplied By	Equals		
<b><u>Length</u></b>						
inches (in)	25.4	millimeters (mm)	0.03937		inches (in)	
inches (in)	2.54	centimeters (cm)	0.3937		inches (in)	
feet (ft)	0.3048	meters (m)	3.281		feet (ft)	
yards (yd)	0.9144	meters (m)	1.094		yards (yd)	
miles (mi)	1.609	kilometers (km)	0.6215		miles (mi)	
<b><u>Area</u></b>						
square inches (in <sup>2</sup> )	645.16	square millimeters (mm <sup>2</sup> )	0.00155		square inches (in <sup>2</sup> )	
square inches (in <sup>2</sup> )	6.452	square centimeters (cm <sup>2</sup> )	0.15		square inches (in <sup>2</sup> )	
square feet (ft <sup>2</sup> )	0.0929	square meters (m <sup>2</sup> )	10.764		square feet (ft <sup>2</sup> )	
<b><u>Volume</u></b>						
cubic inches (in <sup>3</sup> )	16387.0	cubic millimeters (mm <sup>3</sup> )	0.000061		cubic inches (in <sup>3</sup> )	
cubic inches (in <sup>3</sup> )	16.387	cubic centimeters (cm <sup>3</sup> )	0.06102		cubic inches (in <sup>3</sup> )	
cubic inches (in <sup>3</sup> )	0.01639	liters (L)	61.024		cubic inches (in <sup>3</sup> )	
fluid ounces (fl oz)	29.54	milliliters (mL)	0.03381		fluid ounces (fl oz)	
pints (pt)	0.47318	liters (L)	2.1134		pints (pt)	
quarts (qt)	0.94635	liters (L)	1.0567		quarts (qt)	
gallons (gal)	3.7854	liters (L)	0.2642		gallons (gal)	
cubic feet (ft <sup>3</sup> )	28.317	liters (L)	0.03531		cubic feet (ft <sup>3</sup> )	
cubic feet (ft <sup>3</sup> )	0.02832	cubic meters (m <sup>3</sup> )	35.315		cubic feet (ft <sup>3</sup> )	
<b><u>Weight/Force</u></b>						
ounces (av) (oz)	28.35	grams (g)	0.03527		ounces (av) (oz)	
pounds (av) (lb)	0.454	kilograms (kg)	2.205		pounds (av) (lb)	
U.S. tons (t)	907.18	kilograms (kg)	0.001102		U.S. tons (t)	
U.S. tons (t)	0.90718	metric tons (t)	1.1023		U.S. tons (t)	
<b><u>Torque/Work Force</u></b>						
inch-pounds (lbf.in)	11.298	Newton-centimeters (N.cm)	0.08851		inch-pounds (lbf.in)	
foot-pounds (lbf.ft)	1.3558	Newton-meters (N.m)	0.7376		foot-pounds (lbf.ft)	
<b><u>Pressure/Vacuum</u></b>						
inches of mercury (inHg)	3.37685	kiloPascals (kPa)	0.29613		inches of mercury (inHg)	
pounds per square inch (psi)	6.895	kiloPascals (kPa)	0.14503		pounds per square inch (psi)	
Measurement	Subtract	Divide By	Equals/Measurement	Multiply By	Add	Equals
<b><u>Temperature</u></b>						
degrees Fahrenheit (°F)	32	1.8	degrees Celsius (°C)	1.8	32	degrees Fahrenheit (°F)

# MAINTENANCE RECORD

After scheduled services are performed, record the date, odometer reading and who performed the service in the boxes provided after the maintenance interval. Additional information from “Owner Checks and Services” or “Periodic Maintenance” can be added on the following record pages. In addition, retain all maintenance receipts. The owner information portfolio is a convenient place to store them.

## LUBRICATION SERVICE RECORD

KEY TO SERVICES	A – Lubrication & Inspection	A3 – Drive Axle Oil Change	C -- Prescribed Service
	A1 -- Motor Oil & Filter Change	A4 – Wheel Bearing Service	D -- Prescribed Service
	A2 -- Transmission Oil Change	B – Prescribed Service	E – Prescribed Service

MILEAGE	SERVICES										JOB PERFORMED	
	A	A1	A2	A3	A4	B	C	D	E	DATE	BY	
1												
2												
3												
4												
5												
6												
7												
8												
9												
10												
11												
12												
13												
14												
15												
16												
17												
18												
19												
20												
21												
22												
23												
24												
25												
26												
27												
28												
29												
30												

Lube Serv Rec Shortened

LUBRICATION SERVICE RECORD

KEY TO SERVICES

A -- Lubrication & Inspection  
 A1 -- Motor Oil & Filter Change  
 A2 -- Transmission Oil Change

A3 -- Drive Axle Oil Change  
 A4 -- Wheel Bearing Service  
 B -- Prescribed Service

C -- Prescribed Service  
 D -- Prescribed Service  
 E -- Prescribed Service

MILEAGE	SERVICES										JOB PERFORMED	
	A	A1	A2	A3	A4	B	C	D	E	DATE	BY	
1												
2												
3												
4												
5												
6												
7												
8												
9												
10												
11												
12												
13												
14												
15												
16												
17												
18												
19												
20												
21												
22												
23												
24												
25												
26												
27												
28												
29												
30												
31												
32												
33												
34												
35												
36												
37												
38												
39												
40												
41												
42												
43												
44												
45												
46												
47												
48												
49												
50												

Lubrication Service Record





## ***TECHNICAL PUBLICATIONS***

---

**Manager** Vance Buell  
**Editing** Technical Publications

## ***OPERATIONS***

---

### ***TECHNICAL WRITERS***

Robert Buckholtz - OR  
William Birch - OR  
John Banks - OR  
Nathan Bondurant - OR  
Fran Weisenstein - IN  
Thomas Joachim - IN

### ***CREATIVE DESIGNERS***

Kelly Stroble - OR  
Aaron Graham - OR  
Julie Slagle - IN  
Amanda Murray - IN

### ***TECHNICAL ILLUSTRATOR***

Kelly Stroble, Aaron Graham, Josh Means

**The Knight 2005 Technical Writer** Thomas Joachim

**The Knight 2005 Layout Design** Amanda Murray

**The Knight 2005 Cover Design** Julie Slagle

### ***PRINTING***

Holiday Graphics - IN

## ***ONLINE***

---

### **CORPORATE SITE**

[www.monaco-online.com](http://www.monaco-online.com)

### **ONLINE TOURS**

[www.monaco-online.com/tours/](http://www.monaco-online.com/tours/)



**A**

<b>ABS/ATC System - (Anti-lock Brakes)</b> .....	<b>329</b>
Automatic Traction Control System .....	332
<b>Air Conditioner &amp; Heater Controls</b> ...	<b>298</b>
About Refrigerants .....	303
<b>Air Conditioner - Roof</b> .....	<b>155</b>
Heat Pump (Optional) .....	156
Operating Instructions .....	155
Return Air Filters .....	156
<b>Air Dryer</b> .....	<b>323</b>
Air Dryer Cycle .....	326
Air Spring Inspection .....	326
Desiccant Cartridge .....	325
Desiccant-Type - Air Dryer .....	326
<b>Air Intake &amp; Charge Air System</b> .....	<b>372</b>
Air Filter Minder .....	373
Changing Air Filter .....	373
<b>Air Supply System</b> .....	<b>316</b>
Air Governor .....	317
Air Storage Tanks .....	317
<b>Air System Charging (External)</b> .....	<b>318</b>
Air Coupler .....	318
<b>Alternator</b> .....	<b>309</b>
Check Out Procedure .....	309
<b>Appliances-Introduction</b> .....	<b>139</b>
<b>Awnings</b> .....	<b>182</b>
Awning Care & Maintenance .....	187
Awning - Patio .....	183
Front Door (Optional) .....	182
Patio Awning - Eclipse (Optional) .....	187
Window Awning (Optional) .....	183

**B**

<b>Backing Up a Motorhome</b> .....	<b>50</b>
-------------------------------------	-----------

<b>Battery</b> .....	<b>280</b>
Battery Charge Time & Consumption Rate .....	284
Battery Maintenance .....	282
Battery Types .....	280
Battery Voltage & Current .....	283
Electrical Layout .....	285
How It Works .....	280
Testing the Battery .....	281

<b>Battery - Chassis</b> .....	<b>290</b>
--------------------------------	------------

<b>Battery Cut-off Switch</b> .....	<b>259</b>
-------------------------------------	------------

<b>Battery Disconnect - Chassis</b> .....	<b>289</b>
---	------------

<b>Battery Disconnect - House</b> .....	<b>259</b>
---	------------

<b>Battery Specification Chart</b> .....	<b>378</b>
--	------------

<b>Brake Systems</b> .....	<b>319</b>
----------------------------	------------

Air Brakes .....	319
------------------	-----

Brake Systems - Back-up .....	321
-------------------------------	-----

Brake Adjustment/Slack Adjuster .....	320
---------------------------------------	-----

Park & Emergency Brake Systems .....	320
--------------------------------------	-----

<b>Breaking Camp</b> .....	<b>56</b>
----------------------------	-----------

**C**

<b>Carbon Monoxide Detector</b> .....	<b>90</b>
---------------------------------------	-----------

Alarm .....	92
-------------	----

Cleaning .....	92
----------------	----

Operation .....	91
-----------------	----

Testing .....	92
---------------	----

Troubleshooting .....	92
-----------------------	----

<b>Ceiling</b> .....	<b>118</b>
----------------------	------------

<b>Charge Air Cooler</b> .....	<b>366</b>
--------------------------------	------------

<b>Chart - Filters &amp; Belts</b> .....	<b>377</b>
--	------------

<b>Chassis - Introduction</b> .....	<b>315</b>
-------------------------------------	------------

<b>Cold Weather Use</b> .....	<b>229</b>
-------------------------------	------------

<b>Cooktop</b> .....	<b>149</b>
----------------------	------------

Burner Grate .....	150
--------------------	-----

Cleaning .....	151
----------------	-----

Cooktop Cover .....	150
---------------------	-----

Lighting Top Burners .....	150
----------------------------	-----

Operation .....	149
-----------------	-----

**Cooktop with Oven (Optional) .....152**  
 Burner Grate .....153  
 Lighting the Burners .....153  
**Coolant System .....361**  
 Coolant .....363  
 Coolant Additive .....364  
 Maintenance Procedures .....364  
**Countertops - Solid Surface .....122**  
 Laminate .....123  
 Stainless Steel Surface .....123  
**Customer Relations .....17**

**D**

**Dash .....291**  
 Controls .....297  
 Guages .....292  
 Indicator Lamps .....291  
 Parking Brake .....294  
 Switches .....294  
**Dinette .....197**  
 Bed Conversion (Optional) .....197  
 Dinette Bed Conversion (Optional) .....198  
**Distribution Panel (50 Amp) .....274**  
 Energy Management System (Optional) ...275  
 Fuses .....277  
 GFCI Breakers & Outlets .....278  
 Know When to Say No .....279  
 Tools of the Trade .....279  
**Drain Traps & Auto Vents .....229**  
**Drive Axle & Drive Shaft .....340**  
 Lubrication & Maintenance .....342  
 U-Joint Angles Phasing & Driveline  
 Balance .....344

**Driving & Safety .....33**  
 Driving Tips .....39  
 Familiarize Yourself .....33  
 Inspections .....33  
 Ramco Mirror (Optional) .....35  
 Safety Seat Belts .....36  
 Velvac Mirror .....33  
**Dry Camping .....54**

**E**

**Egress (Exit) Window .....94**  
**Electrical Chassis - Introduction .....289**  
**Electrical House - Introduction .....257**  
 Converter (60 Amp) .....257  
 Generator .....258  
 Inverter/Converter (Optional) .....258  
 Shore Power .....258  
**Emergency Procedures - Roadside .....58**  
 Jump Starting .....58  
**Engine - General Information .....348**  
**Engine Shutdown .....354**  
 Extended Engine Shutdown .....354  
**Entertainment Systems .....199**  
 DVD Player (Optional) .....202  
 Hook-ups - TV Cable, Computer &  
 Telephone .....199  
 Satellite System - Prewire .....204  
 Television Antenna .....200  
 Television (Front) w/Lock-out Feature ....199  
 Video Cassette Recorder (VCR)  
 (Optional) .....201  
 Video Selector Box .....202  
**Entry Door .....175**  
 Screen Door Maintenance .....176  
**Entry Step .....173**  
 Maintenance & Lubrication .....174  
 Operation .....173  
**Equipment - Introduction .....173**



**I**

**Interior Care** .....106  
 Cockpit .....106  
 Fabrics .....106  
 Fabric Cleaning Codes .....107  
 Fabric Specifications Chart .....109  
 Leather ..... 112  
 Ultra-Leather ..... 113  
 Vinyl ..... 110  
**Introduction** .....16  
**Inverter/Converter (Optional)** .....268  
 Remote Control ..... 270  
 Troubleshooting ..... 273

**L**

**Leveling System** .....345  
 Hydraulic Leveling RVA ..... 346  
 Manual Leveling System ..... 346  
 Manual Override Retracting Valves ..... 347  
 Retracting Leveling Jacks ..... 346  
**Limited Warranty Transfer**  
**Application** .....27  
**LP-Gas Consumption** .....251  
**LP-Gas Detector** .....88, 238  
 Alarm ..... 89, 239  
 Maintenance ..... 90, 240  
 Testing ..... 89, 239  
**LP-Gas Distribution Lines** .....250  
**LP-Gas Emergency Procedures -**  
**Checklist** .....241  
**LP-Gas Fundamentals** .....244  
**LP-Gas Hose Inspection** .....249  
**LP-Gas Regulator** .....246  
**LP-Gas Safety Tips** .....252  
**LP-Gas System** .....237

**LP-Gas Tank** .....241  
 Measurement ..... 241  
 Tank Filling ..... 242  
 Tank Operation ..... 243  
**Lubrication Charts** .....378

**M**

**Maintenance Record** .....380  
**Metric/U.S. Conversion Chart** .....379  
**Microwave/Convection Oven** .....146  
 Cleaning the Microwave/Convection  
 Oven .....147  
**Mold & Mildew** .....125  
**Monitor Panel (Water Tank)** .....214

**O**

**Oil Recommendations** .....351  
 Cold Weather Engine Operation ..... 353  
 Routine Oil Maintenance ..... 353

**P**

**Pest Control** .....127  
**Pre-trip Preparation - Checklist** .....44  
**Power Sunvisor (Optional)** .....192

**R**

**Radio - Dash** .....206  
 Citizens Band Radio - Prewire ..... 206  
**Rear, Curbside & Roadside View System**  
**(Optional)** .....49  
**Rear Ladder** .....188  
**Rear View System** .....49



**Tires** .....63  
 Air Pressure Checklist .....66  
 Importance of Air Pressure .....63  
 Inspecting & Pressure .....65  
 Storage of Tires - Long Term .....70  
 Supporting When Leveling .....67  
 Tire Pressure Inflation Guideline .....64  
 Tire Rotation .....68  
 Tire Vibration .....68  
 Tread .....68  
 Wheel Mounting .....69

**Toilet** .....227  
 Cleaning .....228  
 Maintenance .....228  
 Operation .....227

**Toilet - Rear Bath (Optional)** .....228  
 Cleaning .....229  
 Operating Instructions .....228  
 Troubleshooting .....228

**Towing Procedures** .....61  
 Disabling the Parking Brake .....62

**Transfer Switch** .....263

**Transmission** .....355  
 Periodic Inspections .....358  
 Shift Selector .....355  
 Transmission Check Light .....357

**Transmission Lubricating Fluid** .....360  
 Fluid Levels - Cold Check .....360

**V**

**Vendor List** .....24

**Views** .....84  
 Curbside .....85  
 Front .....84  
 Rear .....84  
 Roadside .....85

**W**

**Wall Coverings** .....119

**Wall Thermostat** .....154

**Warranty Limited: 2005 Knight** .....1  
 Disclaimer of Consequential and Incidental  
 Damages .....4  
 Events Discharging Warrantor from  
 Obligation Under Warranty .....4  
 How to Get Service .....3  
 Legal Remedies .....5  
 Limitation of Implied Warranties .....2  
 What the Warranty Covers .....2  
 What the Warranty Does Not Cover .....4  
 What We Do to Correct the Problem .....2

**Warranty - Limited Roadmaster**

**Chassis** .....5  
 Disclaimer of Consequential and Incidental  
 Damages .....8  
 Events Discharging Warrantor from  
 Obligation Under Warranty .....8  
 How to Get Service .....7  
 Legal Remedies .....9  
 Limitation of Implied Warranties .....6  
 What the Warranty Covers .....6  
 What the Warranty Does Not Cover .....8  
 What We Do to Correct the Problem .....6

**Warranty Information File** .....10  
 Wood Finish .....10

**Washer-Dryer (Optional)** .....165  
 Operation .....166  
 Washer-Dryer Maintenance .....167  
 Winterizing the Washer-Dryer .....168

**Washer-Dryer Prepared** .....164

**Waste Water System** .....221  
 Black Tank Flush .....223  
 Gravity Drain Hose Dumping .....224  
 Gravity Waste Drain Hose .....223  
 Pressure Pump Dumping (Optional) .....225  
 Proper Waste Disposal .....221  
 Waste Drain & Sewage Tanks .....222  
 What to Put in the Holding Tanks .....222

---

<b>Water -City Hook-Up</b> .....	<b>216</b>
<b>Water Filter - Faucet</b> .....	<b>219</b>
<b>Water Heater</b> .....	<b>159</b>
Before Using the Water Heater .....	159
Burner Compartment .....	163
Draining & Storage .....	163
Ignition Module Function .....	161
Operation .....	160
Pressure Temperature Relief Valve .....	162
Tips .....	163
Water Heater Bypass .....	162
<b>Water Pump</b> .....	<b>217</b>
Troubleshooting .....	217
<b>Water System</b> .....	<b>219</b>
Disinfecting Fresh Water .....	220
Faucet Screens .....	220
Troubleshooting .....	219
<b>Water Systems - Introduction</b> .....	<b>213</b>
<b>Water Tank - Fresh Fill</b> .....	<b>215</b>
<b>Water Tank - Fresh Gravity Fill</b> .....	<b>216</b>
<b>Weighing the Motorhome</b> .....	<b>71</b>
Cargo Carrying Capacity Flowchart .....	80
Four Point Weighing (Example) .....	75
Weight Label .....	74
Weight Record Sheet .....	83
Weight Terms .....	71
<b>Windows</b> .....	<b>123</b>
Condensation .....	123
<b>Window Treatment</b> .....	<b>124</b>
Mini-Blinds .....	124
Day/Night Shades (Optional) .....	125
<b>Winterizing</b> .....	<b>231</b>
Using Air Pressure .....	231
Using Nontoxic Antifreeze .....	232
Using Prevent-A-Freeze System (Optional) .....	233
<b>Wood Care</b> .....	<b>120</b>