

---

**THE KNIGHT  
CONTENTS**

# OWNER'S MANUAL QUESTIONNAIRE 2000

Your suggestions are very important to us. We are continuously improving our manuals to help make traveling as enjoyable as possible. We appreciate you taking the time to answer the following questions. When you are finished simply fold the questionnaire and return it to our technical publications department. Please feel free to add an additional page if you need to.

1. Was the information presented in this manual helpful in acquainting you with your new recreational vehicle? If not please list any area(s) we need to expand or improve on.

---

---

---

2. Were the operating instructions clearly written, and were you able to follow the steps without any difficulty?

---

---

---

3. Was the overall appearance and lay-out of this manual what you expected to see in your new motorhome?

---

---

---

4. Is there any additional information you would like to see added to the owner's manual?

---

---

---

Additional Comments: \_\_\_\_\_  
\_\_\_\_\_  
\_\_\_\_\_

Name \_\_\_\_\_ Model & Year \_\_\_\_\_  
Phone \_\_\_\_\_ Serial Number \_\_\_\_\_  
Address \_\_\_\_\_  
\_\_\_\_\_

Is this your first motorhome? Yes / No



FOLD

**BUSINESS REPLY MAIL**

Monaco Coach Corporation  
91320 Coburg Industrial Way  
Coburg, OR 97408

Attn: Technical Publications

FOLD



***KNIGHT***

## **CHAPTERS**

---

**CHAPTER 1**  
WARRANTY & INFORMATION

**CHAPTER 2**  
OPERATING & SAFETY TIPS

**CHAPTER 3**  
APPLIANCES & EQUIPMENT

**CHAPTER 4**  
WATER & LP GAS SYSTEMS

**CHAPTER 5**  
ELECTRICAL SYSTEMS

**CHAPTER 6**  
UNIT CARE & MAINTENANCE

**CHAPTER 7**  
CHASSIS INFORMATION

# CONTENTS

---

## CHAPTER 1 WARRANTY & INFORMATION

- 1•10 Customer Relations
- 1•10 General Information
- 1•14 Insurance Information
- 1•17 Limited Warranty
- 1•14 Personal Property Information
- 1•10 Reporting Safety Defects
- 1•13 Serial Number Information
- 1•12 Suggestions for Obtaining Service
- 1•11 Taking Delivery
- 1•15 Vendor List
- 1•11 Warranty Information File
- 1•21 Warranty - Limited Warranty Addendum

## CHAPTER 2 OPERATING & SAFETY TIPS

- 2•32 Carbon Monoxide Detector
- 2•37 Checklist - Winter Storage
- 2•37 Checklist - Opening the Motorhome
- 2•24 Driving Safety
- 2•33 Egress Exit Window
- 2•33 Fire Extinguisher
- 2•36 Hitch - Using the Rear Hitch
- 2•34 LP Detector
- 2•31 Smoke Detector
- 2•30 Tire Information
- 2•35 Towing Procedure
- 2•29 Weighing Your Motorhome
- 2•30 Weight Information
- 2•26 While Driving

## CHAPTER 3 APPLIANCES & EQUIPMENT

- 3•53 Air Conditioner (Roof)
- 3•69 Awning - Front Door
- 3•71 Awning - Patio
- 3•70 Awning - Sideout
- 3•68 Booth Dinette
- 3•62 Cable TV/Telephone Hook-Ups
- 3•52 Cooktop
- 3•64 Dash Radio
- 3•62 DSS Prewire
- 3•73 Entry Door
- 3•67 Entry Step
- 3•54 Furnace
- 3•65 Galley & Bathroom Fans
- 3•46 Microwave Oven
- 3•42 Refrigeration Principles
- 3•66 Stepwell Cover
- 3•68 Sofa Sleeper
- 3•69 Storge & Engine Access
- 3•61 Television Antenna
- 3•62 Video Selector Box
- 3•56 Water Heater
- 3•59 Washer/Dryer
- 3•58 Washer/Dryer Prepared

## CHAPTER 4 WATER & LP GAS SYSTEMS

- 4•82 Cold Weather Use
- 4•90 LP Gas Consumption
- 4•90 LP Gas Distribution Lines
- 4•91 LP Gas Detector
- 4•91 LP Gas Regulator
- 4•89 LP Gas System
- 4•90 LP Gas Tank
- 4•91 LP Gas Valves
- 4•88 Tank Capacities
- 4•87 Toilet Operation
- 4•80 Water - City Water Hook-up
- 4•79 Water Pump
- 4•78 Water System
- 4•81 Water System - Disinfecting
- 4•78 Water Tank - Fresh Water Fill
- 4•78 Water Tank (Fresh) - Gravity Fill
- 4•83 Winterizing
- 4•81 Winterizing with Air Pressure
- 4•84 Water System - Troubleshooting
- 4•84 Waste Water System

\*N/A on some units

---

## **CHAPTER 5 ELECTRICAL SYSTEMS**

- 5•104 Battery - How It Works
- 5•113 Controls & Indicators
- 5•119 Dash A/C & Heater Control
- 5•110 Distribution Panel 110 & 12 Volt
- 5•95 Electrical Systems 120/240 AC
- 5•111 Fuses
- 5•114 Gauge Information
- 5•97 Generator 120 AC
- 5•101 GFCI Breakers & Outlets
- 5•100 Inverter/Converter
- 5•123 Rear View System
- 5•124 Steering Wheel
- 5•116 Switch Information
- 5•96 Transfer Switch
- 5•123 Transmission Shift Lever
- 5•102 Twelve Volt DC System

## **CHAPTER 6 UNIT CARE & MAINTENANCE**

- 6•140 Carpet Cleaning
- 6•142 Fabric Specifications
- 6•127 Exterior Care
- 6•132 Interior Care
- 6•139 Stains, Spills, & Scuffs
- 6•144 View - Exterior

## **CHAPTER 7 CHASSIS INFORMATION**

- 7•191 Air Filter - Changing
- 7•191 Air Filter Minder
- 7•162 Air Ride Suspension
- 7•150 Air System
- 7•188 Alternator
- 7•171 Brakes
- 7•171 Braking System (ABS)
- 7•172 Brake - Auxiliary Braking System
- 7•172 Brakes - Maintenance & Troubleshooting
- 7•171 Brake - Parking
- 7•149 Chassis
- 7•195 Chassis Information
- 7•193 Chassis Specifications
- 7•193 Checklist - Items to Carry
- 7•154 Cold Weather Starting
- 7•152 Coolant
- 7•161 Drive Axle
- 7•184 Drive Axle Lubricant
- 7•183 Driveline
- 7•173 Electric Pump & Master Cylinder
- 7•155 Emergency Procedures
- 7•151 Engine
- 7•154 Engine Procedure ( Cold Weather)
- 7•153 Engine Procedure (Normal)
- 7•155 Engine Protection System
- 7•194 Engine Specifications
- 7•184 Filters & Belts
- 7•152 Fuel
- 7•189 Fuel Sending Unit
- 7•188 Fuel Water Separator
- 7•196 Glossary of Terms
- 7•175 Hydraulic Leveling System
- 7•164 Inflation & Weighing
- 7•151 Lubricating Oil
- 7•180 Lubrication
- 7•186 Power Steering Reservoir
- 7•156 Shift Selection
- 7•154 Shutdown - Extended
- 7•178 Slide-out Room
- 7•160 Steering Axle
- 7•183 Steering Gear Box Grease Fitting
- 7•190 Stepwell Cover
- 7•158 Suspension
- 7•194 Tank Capacities
- 7•163 Tire & Wheels
- 7•149 Towing Capacity
- 7•155 Transmission
- 7•185 Transmission Oil
- 7•167 Wheel Alignment

## SIGN INDEX

---



This sign indicates a NOTE or a CAUTION.



This sign indicates a WARNING with additional information attached.



This sign indicates INSPECTION is required.



This sign indicates ASSEMBLY/INSTALLATION or DISASSEMBLY/REMOVAL is necessary.



This sign indicates the specified part requires OIL/LUBRICATION.



This sign indicates a reference to the Warranty INFORMATION FILE located within the gray box inside your motorhome.

**Product information and specifications are shown herein as of the time of printing. Monaco reserves the right to change product specifications, designs and standard equipment without notice and without incurring obligation.**

**CHAPTER 1**  
**WARRANTY & INFORMATION**





## GENERAL INFORMATION

In time you will develop a knack for spotting wonderful little roadside locations by turning off the main highway and exploring. There are many modern recreational vehicle parks (including state, county, and federal parks) with good facilities where you can obtain hook-ups for electrical, water, and sewage connections. Directories are published which describe these parks and the availability of services and hook-ups. On overnight or weekend trips, chances are you will not fill up the sewage holding tank, deplete the water or LP gas supply, or run down the batteries which supply the living area 12 volt DC current. On longer trips, when you have stayed where sewer connections and utility hook-ups were not available, it will be necessary for you to stop occasionally to empty the holding tanks, and to replenish your water and LP gas supply. Many gas stations have installed sanitary dumping stations. Publications are available which list these dumping stations. When you stop for the night, your Monaco motorhome is built to be safely parked in any spot that is relatively level and where the ground is firm. Try to pick as level a parking spot as possible. Your facilities are with you, you are self-contained.

Only by insuring your confidence and satisfaction with our products and services can we have continued success as a manufacturer of motorhomes. We believe a good relationship with our customers is just as important as improving the technical excellence of our products. Your authorized dealer is pleased to help you with instructions about your motorhome and to offer service when you need it. If problems remain after you have consulted your dealer, you are invited to contact our Consumer Service Department. Please have all pertinent information (serial numbers, model number, etc.) when calling. We will work with the dealer and see that every attempt to resolve the matter is made.

**Customer Service Depart.  
Monaco Coach Corporation  
91320 Coburg Industrial Way  
Coburg, Oregon 97408  
1-877-466-6226**

If you believe that your motorhome has a defect which could cause a crash or could cause injury or death, you should immediately inform the National Highway Traffic Safety Administration (NHTSA) in addition to notifying Monaco. If NHTSA receives similar complaints, it may open an investigation, and if it finds that a safety defect exists in a group of motorhomes, it may order a recall or remedy campaign. However, NHTSA cannot become involved in individual problems between you, your dealer or Monaco. To contact NHTSA you may either call the Auto Safety Hot line toll-free at 1-800-424-9393 (or 366-0123 in Washington DC area) or write to:

**NHTSA  
400 Seventh Street  
US Department of Transportation  
Washington, DC 20590**

---

## CUSTOMER RELATIONS

---

## REPORTING SAFETY DEFECTS

## TAKING DELIVERY

Your motorhome has been inspected by factory personnel throughout the manufacturing process. Your dealer performs additional pre-delivery inspections and system checks, and will help you understand the Limited Warranty and complete any necessary forms.

---

### **Dealer Responsibilities**

The dealer must do an orientation of your new motorhome, its systems and components, and their operation. They must also ensure that you receive a complete Owners Packet with warranty cards and registrations for the motorhome and its separately warranted products, including detailed operating and maintenance instructions. The dealer should also review our Limited Warranty and stress the importance of mailing warranty cards and registrations to the manufacturers within the prescribed time limit, to avoid a loss of warranty coverage. They should also assist you in completing those forms and locating serial numbers. They will request that you read all the warranty information, so they can explain anything that is unclear. The dealer should also instruct you on how to get local and out-of-town service on your motorhome and its separately warranted components, whether in or out of warranty.

---

### **Customer Responsibilities**

As a new motorhome owner you are responsible for regular and proper maintenance. This will help you prevent conditions arising from neglect that are not covered by your Monaco Limited Warranty. Maintenance services should be performed in accordance with this Owners Manual, and any other applicable manuals. As the owner, it is your responsibility and obligation to return the motorhome to an authorized dealer for repairs and service (See Limited Warranty). Since the authorized dealer where you purchased your new motorhome is responsible for its proper servicing before delivery, and has an interest in your continued satisfaction, we recommend that Inspection, Warranty and Maintenance Services be performed by the dealership. We suggest that you take your new motorhome on a weekend shake down before leaving on an extended trip.

---

## WARRANTY INFORMATION FILE

In addition to this Owners Manual, you will find a Warranty Information File in your unit. This file contains valuable documents about your motorhome systems and equipment. Be sure you read and understand all the information in this file to help you safely operate, maintain and troubleshoot those items.



**NOTE: Product information and specifications are shown herein as of the time of printing. Monaco reserves the right to change product specifications, designs and standard equipment without notice and without incurring obligation.**

**SUGGESTIONS FOR  
OBTAINING SERVICE  
FOR YOUR  
MOTORHOME**

Know when to take your motorhome in for service. Monday and Friday are busy days for most dealers. Therefore, it makes sense to make a mid-week appointment whenever possible. Ask your dealer if additional time is needed for check in and completion of paperwork.

---

***Prepare for  
the Appointment***

If you are having warranty work done, be sure to have your warranty registration papers with you. All work to be performed may not be covered by the warranty; be sure to discuss additional charges with the service manager. Keep a maintenance log of your motorhome service history. This can often provide a clue to the current problem.

---

***Prepare a List***

Make a written list of the specific repairs needed. It is important for the service manager to be aware of all previous work which has been done on your motorhome. For example, if the motorhome has been repaired due to an accident, it may not seem important, but it could have a significant effect on the dealers diagnosis of a problem.

---

***Be Reasonable With  
Your Requests***

Don't leave a list of 20 items to be serviced and expect to have your motorhome back by five o'clock. If you list a number of items, and you must have your motorhome back by the end of the day, discuss the situation with the service manager and list your items in order of priority. Expect to make a second appointment for work not completed or for the parts that may need to be ordered.

---

***Sorry, No  
Looking Over  
the Technicians  
Shoulder***

Please don't be offended when you are told you can not watch the work being done. Insurance requirements forbid the admission of customers to a service area.

---

***Inspect the Work  
Properly***

Check out the service or repair job when you pick up your motorhome and notify the service manager of any dissatisfaction. If circumstances prevent returning for immediate corrective work, make an appointment as soon as possible.

FOR YOUR OWN REFERENCE

**SERIAL NUMBER INFORMATION**



Refer to the Manufacturer's individual Owner's Manuals for serial number locations that are not listed below.

**Motorhome** Serial Number \_\_\_\_\_

**Motorhome** Federal Vehicle Identification Number (VIN) \_\_\_\_\_

**Door Key** Number \_\_\_\_\_

**Range** Model & Serial Number \_\_\_\_\_  
(Located under top burner plate)

**Microwave** Model & Serial Number \_\_\_\_\_  
(Located behind door on case)

**Refrigerator** Model & Serial Number \_\_\_\_\_  
(located inside refrigerator compartment)

**Diesel Generator (optional)** Model & Serial  
Number \_\_\_\_\_  
(Located in outside compartment on generator)

**Roof Air Conditioner** Model & Serial Number \_\_\_\_\_  
(Located under top cover on air conditioner)

**LP Generator** Model & Serial  
Number \_\_\_\_\_

**FOR YOUR OWN REFERENCE**

**PERSONAL PROPERTY INFORMATION**

Item

Serial Number

Value

**INSURANCE INFORMATION**

Company \_\_\_\_\_

Policy Number \_\_\_\_\_

Agent's Name & Address \_\_\_\_\_

Business Phone \_\_\_\_\_

Emergency Phone \_\_\_\_\_

Renewal Date(s) \_\_\_\_\_

## VENDOR LIST

Air Conditioner Roof  
Dometic Corp.  
Tel: (219) 463-4858

Air Conditioner Dash  
Evans Tempcon Inc.  
Tel: (800) 878-7147

Alternator  
Dixie Electric  
Tel: (800) 478-0608

Awnings  
CareFree  
Tel: (800) 621-2617

Axle Front  
Westport  
Tel: (216) 431-2000

Axle Rear  
Dana Spicer  
Tel: (800) 666-8688

Bathroom Exhaust Fan  
Fan-Tastic Vent  
Tel: (800) 395-4045

Batteries  
Nationwide Batteries  
Tel: (800) 367-1407

Brakes - ABS  
Meritor Wabco  
Tel: (800) 535-5560  
[www.meritorauto.com](http://www.meritorauto.com)

Brake (Hydraulic)  
Bosch Braking System Corp.  
Tel: (800) 521-5462

Brake ( Exhaust)  
Jacobs Brake  
Tel: (800) 876-5253

Carbon Monoxide Detector  
Safe-T-Alert  
Tel: (800) 383-0269

Flooring  
Congoleum  
Tel: (800) 934-3567  
Fax: (800) 274-3266

Engine  
Cummins  
Tel: (800) 343-7357

Entry Step  
Kwikkee  
Tel: (800) 736-9961

Generator  
Onan  
Tel: (800) 888-6626

Hydraulic Leveling Jacks  
RVA  
Tel: (760) 746-5732

Inverter  
Trace Engineering  
Tel: (360) 435-8826  
[www.traceengineering.com](http://www.traceengineering.com)

LP Tank  
Brunner  
Tel: (800) 753-8265

Microwave  
Sharp Electronics Corp.  
Tel: (800) 237-4277

Power Gear Slide Out  
Power Gear  
Tel: (800) 334-4712

Rear Vision System  
Jenson  
Tel: (800) 732-6866

Refrigerator

Norcold

Tel: (800) 543-1219

Television Antenna

Winegard

Tel: (319) 754-0600

Tires

Goodyear Tire & Rubber Co.

Tel: (877) 484-7376

Toilet

Sealand

Tel: (800) 321-9886

Transmission

Allison Transmission

Tel: (800) 524-2303

Washer / Dryer

Splendide (optional)

Tel: (800) 736-4127

Water Pump

Shurflo

Tel: (800) 762-8094

Water Heater / Furnace

Atwood Mobile Products

Tel: (801) 972-4621

Windshield Wipers

Diesel Equipment

Tel: (336) 373-8331

Wheel Simulators

Jae Enterprises

Tel:(800) 626-3367



**MONACO COACH  
CORPORATION  
NONCOMMERCIAL  
USE LIMITED  
WARRANTY**

Monaco Coach Corporation (Monaco) warrants to you, the original purchaser, for a period of (1) year from the date of purchase or 24,000 miles, whichever comes first, that this Monaco Coach Corporation motorhome shall be free of SUBSTANTIAL DEFECTS (as defined below) in material and workmanship attributable to Monaco. Items incorporated in the motorhome that were purchased, manufactured and/or installed outside Monaco's factory are not covered by this warranty, but may be covered by the Seller, Manufacturer and/or Installer of the particular item.

Monaco will repair the defect, pay the reasonable parts and labor charges to perform the repair, and in the event that original consumer purchaser's motorhome is inoperative due to malfunction of a warranted part, Monaco will pay the cost of having the motorhome towed to the nearest Monaco authorized repair facility. If your motorhome must be towed, you must contact Monaco, prior to incurring the towing charges, for directions to the nearest authorized repair facility. Monaco reserves the right to make use of new and/or remanufactured parts, at its own option, in making such repairs.

Monaco reserves the right to change the parts and designs of its motorhomes from time to time without notice and with no obligation to make corresponding changes in its previously manufactured motorhomes.

If you are a commercial purchaser, please refer to Monaco's 90-day limited warranty which will be provided upon request.

---

***"Substantial Defect"  
Definition***

A part or system qualifies as a substantial defect under this warranty only when it fails to perform substantially, within the design specifications for the part or system and the failure is attributable to work performed by Monaco.

---

***Warranty Recovery  
Limitations &  
Disclaimers***

No person shall be entitled to recover from Monaco any consequential or incidental damages resulting from any defect in the motorhome. There is no warranty of any nature made by Monaco beyond that contained in the warranty. All implied warranties of merchantability or of fitness for a specific purpose are limited in duration to the warranty period of one (1) year from purchase by original consumer purchaser or 24,000 miles, whichever comes first. All implied and express warranties on items not covered are disclaimed, including any warranties of merchantability or fitness for a particular purpose and such uncovered parts or systems are sold "as is". You and any supplier who may warrant such component parts assume the entire risk as to the quality and performance of such uncovered parts and systems. If the uncovered parts and systems prove defective, you and any supplier that may warrant that part or system, and not Monaco, assume the entire cost of repair with respect to such systems or parts.

Some states do not allow limitations on how long an implied warranty lasts or the exclusion of limitation or incidental or consequential damages,

so the above limitations may not apply to you. This warranty gives specific legal rights and other rights which may vary from state to state.

Items purchased, manufactured and/or installed outside Monaco's factory are not covered by this particular item. The engine, the transmission and its components, batteries, tires, axles and domestic appliances are not covered under this warranty. Any warranties covering these items are provided by the manufacturer of such items and are not the responsibility of Monaco. The domestic appliances that are not covered include, without limitation, the refrigerator, stove, oven, microwave, ice maker, water heater, furnace, television, stereo, radio, compact disc player, video cassette player/recorder, washer, dryer and all other domestic appliances.

### **What is Not Covered**

Any service contracts offered by a dealer are not warranties of Monaco. All rights and remedies on such contracts are between the purchaser, the dealer and the administrator of the service contract.

This warranty does not cover any motorhome that is rented, leased, or loaned for use by anyone other than the original owner.

Damage or corrosion due to accidents, misuse or alterations is not covered under this Warranty. By definition, this shall exclude from coverage any accident or damage caused by off road use, collision, fire, theft, freezing temperatures, vandalism, riot, explosions, objects striking the motorhome, driving over curbs, overloading, racing or unauthorized motorhome alterations. Additionally, warranty coverage shall not apply if the odometer has been stopped, disconnected or altered. Basic instructions for proper use of this motorhome are discussed in the Owner's Manual.

Damage or surface corrosion due from airborne fallout (including chemicals, tree sap, etc.) stones, hail, earthquake, water, acid rain, flooding, windstorm, lightning, road salt, road salt spray, blowing sand, road surface debris or other environmental factors are not covered under this Warranty.

Damage caused by off road use or a lack of proper maintenance, as described in the Maintenance schedule, in any applicable instructions from Monaco, in any instructions from a system or component part manufacturer, in instructions from a repair facility or as common sense would dictate, are not covered. Damage caused by a failure to use the fuel, oil and lubricants recommended in the Owner's Manual, is not covered under this Warranty. Proof of proper maintenance is your responsibility, therefore you should keep all receipts evidencing any maintenance performed. Maintenance expenses shall be borne by you. Normal wear-and-tear is not covered under this Warranty.

Any usage beyond the design intentions will relieve Monaco of responsibility under this Warranty. Usage of this motorhome in a manner inconsistent with the Owner's Manual directions will also invalidate the Warranty in regard to defects caused by the inconsistent usage.

### **Usage Limitations**

Misuse or neglect of the motorhome, failure to provide reasonable and necessary maintenance, unauthorized alteration or modification, or improper loading

accident shall discharge Monaco from any and all obligation under this warranty.

This limited warranty does not cover any motorhomes subjected to any commercial or rental use whatsoever. Any such commercial or rental use voids this limited non-commercial consumer warranty. The sole coverage available to any purchaser making any commercial or rental use of a motorhome is defined by Monaco's limited commercial warranty, which contains different terms. Monaco considers any commercial or rental use whatsoever as voiding this limited warranty and limiting the owner to coverage, if any, available under Monaco's written commercial limited warranty. For the purposes of this paragraph, any use, even part-time or only occasionally, in any business or business-oriented activity, constitutes commercial use.

---

### ***Your Expense Responsibility***

You shall be responsible for and bear all expenses incurred in delivering the motorhome to Monaco's factory or authorized repair facility for warranty service including, but not limited to, the costs of transporting the motorhome for warranty service, lodging and meals. Unless prohibited by law, if Monaco deems it necessary to have the motorhome returned to the factory you shall be responsible for and bear all expenses incurred in delivering the motorhome to Monaco's factory.

Regular maintenance including cleaning, polishing, lubricating, replacing filters, replacing worn brake linings and performing other normal maintenance services required shall be at your expense. See the Maintenance Schedule and Owner's Manual for recommended maintenance procedures.

---

### ***Mandatory Notice***

**To the extent permitted by law, you must notify Monaco (not just your dealer) in writing that there have been two unsuccessful repair attempts or more than 15 days aggregate repair time on substantial defects. This notice must be given to Monaco immediately after the second repair attempt of any substantial defect, or immediately after 15 days of aggregate repair time on substantial defects, during the term of the warranty. To the extent permitted by law, failure to provide Monaco with the required notice voids this warranty. If a claimed defect is related to an appliance that is found to be covered by this warranty or any other, it shall be limited to replacement of that appliance, nothing more. To the extent permitted by law, you agree all disputes with Monaco will be resolved exclusively by binding arbitration under the rules of the American Arbitration Association in:**

- A. Elkhart, Indiana or Eugene, Oregon at buyer's choice;**
- B. As otherwise mutually agreed; or,**
- C. As determined under the rules of the American Arbitration association.**

---

**Procedure for Obtaining  
Warranty Service**

If towing is necessary, phone Monaco prior to towing for assistance. A toll free number (877-466-6226) is provided for your convenience.

To obtain Warranty Service, call the authorized repair facility nearest you for an appointment. Contact Monaco's Warranty Department for assistance in locating an authorized warranty repair facility in your location. The name of authorized service facilities can be obtained by contacting Monaco (Coburg,OR) for the location nearest you.

You must deliver the motorhome to an authorized service center within a reasonable time after discovery of the defect and in no event after the expiration of the appropriated warranty period. Warranty Service can only be obtained at Monaco's authorized dealers and service centers. No other claims will be honored.

You must request that Monaco be consulted BEFORE work commences, to avoid possible delay and reduction of reimbursement requests, and you must present your owner identification card to the Service Manager.

All requests for reimbursement for warranty service must be received by Monaco on a Warranty Reimbursement Form, with evidence of the charges and the work performed, at the address noted below, within 60 days of the date the services were performed. If you cannot obtain satisfactory Warranty Service from authorized dealers or service centers, or if a substantial defect has not been resolved after the second repair attempt, you must contact Monaco in writing immediately to seek a satisfactory resolution of the situation. Written notice to a dealer, or an authorized or unauthorized repair facility, shall not constitute written notice to Monaco of a continuing problem, or unsatisfactory warranty service.

As a goodwill gesture, and without any legal obligation to do so, Monaco often provides reasonable assistance to the original consumer purchaser in contacting the manufacturers of components not warranted by Monaco, if the original consumer purchaser believes such components to be defective. The original consumer purchaser may request such assistance by contacting Monaco's Warranty Department, as listed below.

As a goodwill gesture, and solely to assist the purchaser who does not desire to take the motorhome to an authorized repair facility, Monaco may also refer you to an unauthorized repair facility, and may pay for a repair. Whether or not Monaco pays for such repair efforts shall not constitute a repair attempt by an authorized repair facility or Monaco.

---

Request for warranty payments must be received by Monaco within 60 days of service rendered. Requests for reimbursement submitted beyond 60 days will not be paid.

**Payment  
for Service**

---

No person, dealer or repair agent has the authority to enlarge, amend or modify this warranty. This Warranty gives only those legal rights specifically enumerated herein. You may have other legal rights which vary from

**Authority to  
Enlarge Warranty**

## Warranty Applicability

state to state.

This Warranty applies to covered parts of Monaco Coach Corporation motorhomes and Roadmaster Chassis registered in the United States and/or Canada.

**\*Monaco Coach Corporation Attention  
Attention Warranty Department  
91320 Coburg Industrial Way  
Coburg, OR 97408  
1-877-466-6226**

---

## LIMITED WARRANTY / ADDENDUM

This Addendum provides expanded warranty coverage to the terms of the Monaco Coach Corporation Noncommercial Use Limited Warranty (the “Limited Warranty”) and applies to the 2000 Monaco motorhomes specified below:

**Roadmaster Chassis** The warranty period on the Roadmaster Chassis is increased to two (2) years or 24,000 miles from the date of purchase, whichever occurs first. Covered parts remain as defined in the Limited Warranty. This section applies to the following 2000 model year Monaco motorhomes: Signature Series™, the Executive®, Dynasty®, Windsor®, Diplomat™ and Knight™.

**Extended Frame Structure Warranty** Monaco Coach Corporation warrants that the steel or the aluminum frame structure of the sidewalls (excluding slide-outs), roof, and rear and front walls will be free from substantial defects in the materials and workmanship for a period of 60 months or 50,000 miles from the date of purchase, whichever occurs first. This section applies to the following 2000 model year Monaco motorhomes: Signature Series, the Executive, Dynasty, Windsor, Diplomat, LaPalma™ and Knight™.

All other terms conditions, limitations and exclusions of the Limited Warranty remain unchanged and effective and are incorporated into this addendum.

---

**CHAPTER 2**  
**OPERATING & SAFETY TIPS**



This section contains knowledge and driving information that you should know and be aware of.

## **DRIVING SAFETY**

The key for safely operating your motorhome is inspection. Any defect found could result in problems on the road that will cost time and money. There are several states that require your motorhome be inspected prior to registration. A systematic inspection conducted prior to moving your motorhome will ensure nothing is overlooked. This also assists you in becoming familiar with the motorhome. Start by looking at the general condition and the area around your motorhome for hazards to the movement. Look high and low as you walk around your motorhome.

### ***Inspections***

- The power cord is disconnected and stowed
- The water hose is disconnected and stowed
- TV antenna fully retracted resting in the cradle
- Awnings stowed and locked in place
- All compartment doors closed and latched
- All the Leveling jacks fully retracted
- Any obstacles to avoid when driving off
- Slide room moved inward
- Wheels and tires, inspected
- No puddles or fluid leaks under the coach
- No physical damage
- Entry door access

### ***General Condition***

- Fluid levels
- Belts and hoses
- Wiring, loose and frayed
- Leaks on engine or transmission
- Start engine and listen for noises

### ***Check the Engine***

- Gauges and controls all operating and functioning properly
- All windows and vents closed
- All cabinet doors and drawers closed
- All interior lights switched OFF
- All items secured

### ***Inside the Coach***



## **Before You Start Out**

There are differences between your motorhome and conventional passenger automobiles. You should always be aware of those differences.

As you first sit down in the driver's seat, you'll notice that you're sitting up higher and further to the left than in a passenger automobile. Your perspective of the road will therefore be different. Because of the driver's seat location and the configuration of the motorhome itself, you will rely on the outside mirrors to line up with the center line of the road, and to check the conditions behind you. Your dashboard may contain more gauges and controls than are normally found in passenger automobiles. You should become familiar with these devices and how they operate before starting out.

---

## **Safety Seat Belts**

All occupants must be furnished with and use seat belts while motorhome is moving. Driver's seat, and all other seats designed to carry passengers while motorhome is in motion, are equipped with safety seat belts. While traveling, do not occupy beds or any seats that do not have a safety belt. Seat belts must only be used on permanently mounted seats. Driver's seat must be locked in the forward facing position while motorhome is in motion. Do not use a seat belt on more than one person.

To fasten the seat belt, pull the belt out of the retractors and insert the tab into the buckle; you will hear a click when the tab locks into the buckle. Seat belt lengths automatically adjust to your size and sitting position. Do not route belts over armrest.



**WARNING: Seat belts must be pointed in a forward position and seat belts fastened while the motorhome is in motion. Avoid seat rotation while in transit. Children must not be transported unrestrained. Infants must be placed in approved safety seats. Small children must be restrained in child safety seats. Failure to comply with these rules can cause injury or death.**

---

## **Ready to Leave Checklist**

- Drain and flush out the holding tanks. Close the valves all the way and install the cap securely.
- Disconnect the sewer hose, flush with clean water and store it in an outside compartment.
- Fill the fresh water tank. Disconnect and store the fresh water hose.
- Disconnect the shore line and rewind it.
- Disconnect the cable TV and phone hookups and lower the TV antenna.
- Retract any awnings and secure them for transport.
- If applicable, lower the satellite dish.
- Close all roof vents.
- If applicable, retract the leveling jacks to their travel posi-

tion.

- Check the engine oil, transmission fluid, engine coolant, power steering fluid, windshield washer fluid and tire inflation.
- Secure any loose, heavy or sharp objects in the motorhome or its service compartments.
- Turn off the interior lights, water heater, furnace and water pump.
- Check the LP gas tank gauge to make sure there is LP gas available.
- Check the fuel gauge and lights on the motorhome.
- Fasten bi-fold and pocket doors securely.
- Walk around your motorhome one last time to make sure everything is stored away and outside compartments are closed and locked.
- Visually check front oil bath hubs, fluid level, leaks?
- Pull forward, clean the site if necessary and check for forgotten items.
- Secure and lock the entrance door.

---

Because your motorhome is longer than the average automobile, the turning radius will be wider. Therefore, it is always a good idea to be cautious when turning the motorhome. Keep a close eye on the rear of the motorhome, making sure it will clear potential obstacles. Your motorhome is also heavier than an average automobile, with a higher center of gravity. Those factors may make it difficult to change the momentum of your motorhome. Swerves and sharp turns, especially at high speeds, could result in the loss of control of the motorhome. You should always keep that in mind and drive with the extra caution necessary to avoid situations which might require quick momentum changes. You will find that your motorhome will travel safely and comfortably at highway speed limits. However, it will take longer to reach that speed and you must always bear this in mind when overtaking and passing another vehicle. Allow more time to go around a vehicle, because you cannot cut back as quickly, due to longer length of your motorhome. When descending a long hill, use the exhaust brake. The transmission and engine will help in controlling downhill speed and can lengthen brake life. The distance required to stop the motorhome will be greater than an automobiles. Even though your motorhome is equipped with brakes designed for the Gross Vehicle Weight Rating (GVWR), we suggest that you practice stopping away from traffic until you become accustomed to your motorhome stopping distance. When backing up, have your co-pilot get out of the motorhome and walk to the driver's side rear corner. The co-pilot can watch for any obstacles and give hand signals to you as you back up. When traveling, make sure that any bridges you cross can support the weight of your motorhome. Check the tonnage limit of bridges before crossing them. Signs are normally posted at bridge entrances. Know and observe the laws where you will be traveling as they may vary from state to state.

Always carry road flares or reflective warning signs to display if necessary.

---

## WHILE DRIVING

## **Emergency Stopping**

Pull off the roadway as far as possible for emergency stopping or tire changing. Turn ON your motorhome hazard warning flasher when parked alongside traffic lanes. Set the parking brake.

---

## **Backing In**

If your destination does not have drive through sites, pick a good level site and back in carefully. We suggest that you stop near the site, get out of the motorhome and observe the surrounding area. Check for low-hanging tree limbs, posts, large rocks or other obstacles. Try to choose a site that is on the driver's side, so that you can see what the rear of the motorhome is doing. With the site on the passenger side you would be backing on your blind side, which is more difficult, even with side mirrors as a guide. When site conditions are satisfactory, maneuver the motorhome into a position for backing into the site space. Back up the motorhome slowly using the side mirrors as a guide, or have another person outside to help guide you until the motorhome is in the desired position.

---

## **Parking**

Bring the motorhome to a complete stop using the service brakes and keep your foot on the brake pedal. Allow the engine to come to a low idle (500 to 800 RPM). Move the shifter to the P (PARK) position, this engages the park pawl. Apply the parking/emergency brake by pulling up on the knob. When the parking/emergency brake is set, remove your foot from the brake pedal. The motorhome is now at a point you may begin shut off or set up procedures.



**NOTE: Chock all the wheels securely if you are leaving the motorhome.**

---

## **Set Up Procedures**

- Level the motorhome as directed under “Leveling Jacks” described in the chassis section.
- Connect the 120 AC power, more information is described in the electrical section.
- Open the LP gas tank valve.
- Connect the fresh water supply if fresh water supply is available.
- Connect the waste drain hose to the sewer hookup.
- If applicable, start the refrigerator, water heater and furnace. (Most appliances should be operated on gas at first).

---

## **Tips for Dry Camping**

For extended dry camping, management of all your resources is essential. All motorhomes have large batteries and plenty of water and holding tank capacity. With a little care and forethought it is possible to go quite a long way with only the wonderful amenities you bring with you.

Conserve water! Your motorhome holds a lot, but it goes down the drain fast if you let it. Don't waste water you don't actually use. Use the manual valve on the shower head and turn the water off and on as needed while showering. You can reduce water needed for a shower by as much as 2/3. Do not let the water run in the

sink while you do other things, such as wiping up the kitchen or brushing your teeth.

Charge the batteries when they are half down. At half charge the battery voltage will be 12.2 V. Use a hydrometer for testing. A good rule of thumb is to run the generator for three to four hours daily and you should have plenty of power available. Never use batteries until they are totally dead: when lights “dim-out.” Each time this happens, the batteries ability to recharge up to full capacity is diminished. This damage is cumulative and will eventually render a battery useless.

If you are in a habit of starting the engine regularly, remember that the alternator output is lower at idle, and that even at a fast idle it may take as much as an hour to replace what it took to start up the engine. Also realize that running the engine for a short time may increase moisture contamination in the fuel and oil. It’s better to run it less often and run it longer, for perhaps an hour. The good news is this can be included in your battery recharge schedule.

Solar panels can greatly increase the time you can operate between battery charges. Remember one solar panel is just break even for parasitic loads. A pair of five amp panels, combined with very careful husbanding of battery usage in sunny weather, might actually allow the sun to replace what you use each day!

Remember that different motorhomes have different equipment and everyone has different habits and expectations. The general guidelines below will provide a useful starting point for building your own schedule and regimen for extended stays where power and water are not available. You too can become less dependent on hookups.

- Make sure to turn all appliances to propane.
- The battery cut off switch will need to be left on.
- You may want to buy extra solar panels.
- You may want to relocate the chassis battery and add extra house batteries.
- Get to know your batteries.
- Understand your inverter.
- One continuous duty solenoid is 0.7 amp draw.
- A 13”TV has a 1.7 amp draw.
- A porch light 2.0 amp draw.
- One fluorescent dual bulb light 0.9 amp draw.

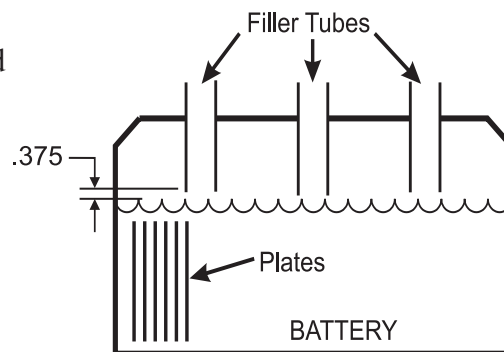

Battery State of Charge	Spec. Gravity	Voltage
100%	1.265	12.7
75%	1.225	12.4
50%	1.190	12.2
25%	1.155	12.0
Discharged	1.120	11.9 or Less

NOTE: The distilled water level in battery should be 3/8" below the filler tube.

## WEIGHING YOUR MOTORHOME

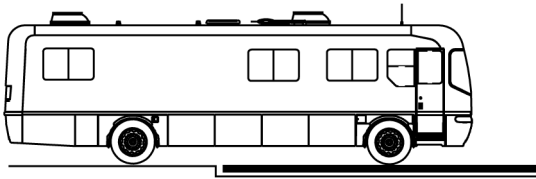

**Reading 1** - GAW (Gross Axle Weight) front axle on the scale only (loaded for travel).

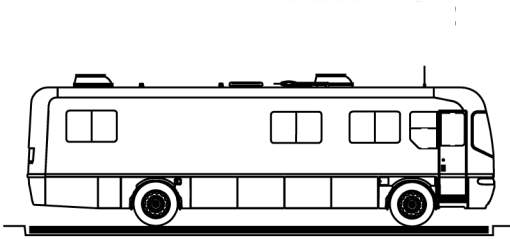

**Reading 2** - GVW - (Gross Vehicle Weight) entire unit on the scale (loaded for travel).

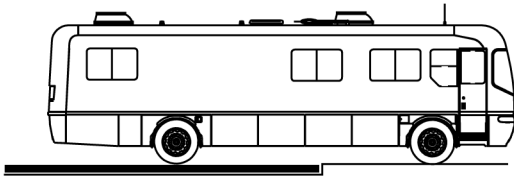

**Reading 3** - GAW - (Gross Axle Weight) rear axle on the scale only (loaded for travel).

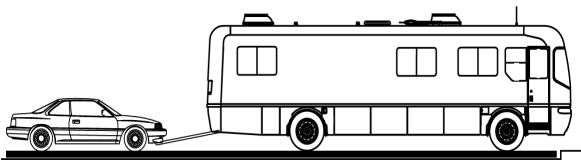

**Reading 4** - GCW - (Gross Combined Weight) entire unit on the scale with towed vehicle (loaded for travel).



**NOTE:** Compare the actual weights to the ratings to ensure you are below maximum ratings.



**CAUTION:** Consideration should be taken when loading the motorhome. Heavy objects should be kept as low as possible, preferably on the floor. Load weight should also be distributed as evenly as possible to ensure proper weight and balance.

## WEIGHT INFORMATION

Model \_\_\_\_\_

GVWR \_\_\_\_\_ UVW \_\_\_\_\_

NCC \_\_\_\_\_ GCWR \_\_\_\_\_

This motorhome is capable of carrying up to \_\_\_\_\_ GAL. of fresh water (including water heater) for a total of \_\_\_\_\_ LBS.

**REFERENCE:**

- The weight of fresh water is 8.33 LBS/GAL.
- The weight of LP gas is 4.5 LBS/GAL (on average).

**GVWR** • Gross Vehicle Weight Rating means the maximum permissible weight of this motorhome. The GVWR is equal to or greater than the sum of the unloaded vehicle weight plus the net carrying capacity.

**UVW** • Unloaded Vehicle weight means the weight of this motorhome as built at the factory with full fuel, engine oil, and coolants. The UVW does not include cargo, fresh water, LP gas, occupants, or dealer installed accessories.

**NCC** • Net Carrying Capacity means the maximum weight of all occupants including the driver, personal belongings, food, fresh water, LP gas, etc., that can be carried by this motorhome (NCC is equal to or less than GVWR minus UVW).

**GCWR** • Gross Combination weight rating means the value specified by the motorhome manufacturer as the maximum allowable loaded weight of this motorhome with its towed trailer or towed vehicle.

**GAWR** • GAWR means load-carrying capacity specified by the manufacturer of a single axle system, as measured at tire ground interfaces.

## TIRE INFORMATION

To accurately determine the proper inflation pressure, the motorhome should be weighed after it has been fully loaded. First, position the front wheels on the scale and take a weight reading. Divide this reading by 2 to determine the load carried by each tire/wheel.

Next position the rear drive wheels on the scale and take the weight reading. Divide this reading by 4 to determine the load carried by each tire/wheel to determine the proper tire pressure.

**Weigh/Inflation Pressure**

PSI Cold		70	75	80	85	90	95	100	105	110	115
255/70R22.5	Dual	3585	3765	3970	4110	4275	4410	4455	4610	4675(G)	5070(H)
	Single	3815	4005	4190	4370	4550	4675	4895	5065	5205(G)	5510(H)

## SMOKE DETECTOR



Smoke detector.

Statistics show that most fire casualties are not caused by direct flame, but by less visible smoke (products of combustion). The smoke detector responds to both visible and invisible products of combustion. The smoke detector will automatically return from alarm to normal state when the reason for activation, the presence of smoke, is completely removed. There are common causes of fires that kill: smoking in bed, leaving children unattended and cleaning with flammable fluids. Please be safety conscious and avoid unnecessary risk.

---

### How to Test

To test the electronics of the alarm press the test button on the cover of the smoke alarm for a few seconds. The smoke alarm will sound by making a continuous loud beep. To complete the test sequence release the button and the alarm should stop.



**NOTE:** Test the smoke alarm operation after the motorhome has been in storage before each trip, and at least once a week during use.



**WARNING:** The smoke detector is intended to help reduce the risk of tragedy. Additional smoke detectors may further help to reduce the risk. Proper use and care of your smoke detector could save your life.

---

### Maintenance

Vacuum the slots in the cover and sides with a soft brush attachment every month. Your smoke alarm should be cleaned every six months to help keep the unit working efficiently.

The battery should power the smoke alarm for at least one year under normal use. When the battery reaches the end of its normal life, a low battery warning (intermittent beeping) will indicate the need for battery replacement.

---

### Trouble Shooting

If the alarm does not sound when the test button is pushed or with a smoke test, try the following:

- Inspect it for obvious damage.
- Check for the recommended battery type.
- Check the battery for proper connection, or replace the battery if needed.
- Gently vacuum as recommended.

If these procedures do not correct the problem, do not attempt repairs. If the smoke alarm is within the warranty period and the terms indicate the nature of problem, return the unit to your dealer. Smoke detectors beyond warranty cannot be economically repaired.

Abnormal air conditions may cause the highly sensitive smoke alarm to give a false alarm. If no fire is apparent, ventilate the room and/or blow fresh air into the motorhome until the alarm stops. Once cleared the smoke alarm will automatically reset. Dust can lead to excessive sensitivity. Vacuum as needed.

Your motorhome is equipped with a carbon monoxide detector. Carbon monoxide (CO) is a colorless, odorless and tasteless gas. Even low levels of CO have been known to cause brain and other vital organ damage in unborn infants, with no effect on the mother. In cases of mild exposure the symptoms include: a slight headache, nausea, vomiting, and fatigue. Symptoms for medium exposure are a severe throbbing headache, drowsiness, confusion and fast heart rate. Extreme exposure can result in unconsciousness, convulsions, cardio-respiratory failure and death. Young children and household pets may be the first effected. Your CO detector is designed to detect the toxic CO fumes that result from vehicle exhaust and incomplete combustion sources like a furnace, gas stove, or water heater. Consequently, it is uncommon for household smoke from cigarettes or normal cooking to cause the alarm to sound.

## CARBON MONOXIDE DETECTOR

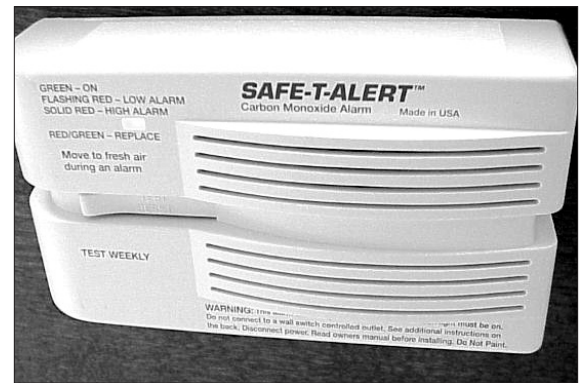

Carbon monoxide detector located in bedroom curbside underneath night stand cabinet secured to outside wall.



**WARNING: Activation of this device indicates the presence of carbon monoxide (CO) which can be fatal to you. A concentration of above 100 PPM will cause a warning condition. Individuals with medical problems may consider using detection devices with lower carbon monoxide alarming capabilities. Prolonged exposure to the horn at a close distance may be harmful to your hearing.**

The detector is equipped with a self-cleaning CO sensor and requires a ten minute initial warm-up period to clean the sensor element and achieve stabilization. The green power light should be lit when the power is on. If the light is not lit, turn off the power and check all wire connections. If the power is on and the connections are correct but the indicator still does not light, the detector should be returned for service. Do not attempt to fix the detector yourself. The indicator light displays a specific color to monitor the conditions as follows:

- **Green** - indicates an “ON” or normal condition: the CO detector has power and is sensing air for the presence of CO gas. The alarm horn will not sound.
- **Yellow** - indicates a “trouble” or malfunction condition; the alarm horn will sound and cannot be reset by the TEST/RESET button. The CO detector is not working properly and must be immediately replaced or repaired.
- **Red** - indicates an “alarm condition”, the detector has sensed the presence of a hazardous level of carbon monoxide. The alarm horn will sound continuously until reset by the RESET switch.

When the alarm sounds, you should have the detector and the motorhome checked by an authorized service technician as soon as possible. Never discon-

## Operating Instructions

## When the Alarm Sounds



nect a CO detector to silence an annoying alarm. Evacuate the motorhome immediately when the RED light is lit and the alarm sounds. Do a head count to check that all persons are accounted for. Call the nearest fire department and ask them to determine the source of the carbon monoxide. Do not re-enter the motorhome until it has been aired out and the problem corrected.

---

### Testing the Carbon Monoxide Detector

Test the carbon monoxide detector operation after the motorhome has been in storage, before each trip, and at least once a week during use. You can test the alarm by holding the test button in until the alarm sounds. The alarm will stop beeping in about 30 seconds.

---

### Cleaning the Detector

Use a vacuum cleaner to remove dust and any other buildup on the detector, do not wash it. Wipe the detector with a damp cloth and dry it with a towel. Do not open the detector for cleaning. Do not paint the detector. We recommend replacing your carbon monoxide detector every 10 years.

---

### FIRE EXTINGUISHER



The fire extinguisher in your motorhome is located near the main entrance door. Please read the operating instructions that are printed on the fire extinguisher. If there is any doubt on the operation of the fire extinguisher then you and your family should practice using it, then replace or recharge it. Inspect the fire extinguisher at least once a month. Do so more frequently if the extinguisher is exposed to weather or possible tampering. Do not test the extinguisher by partially discharging. This will cause a loss of pressure.

#### Use the PASSWORD!

- Pull the pin to unlock the extinguisher.
- Aim at the base (bottom) of the fire and stand 6-10 feet away.
- Squeeze the lever to discharge the agent.
- Sweep the spray from left to right until totally extinguished.

---

### EGRESS EXIT WINDOW

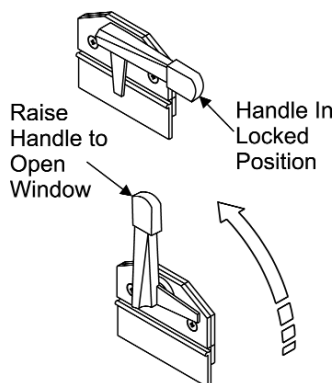

Egress Window Handle

Your motorhome is equipped with an egress exit window. This window is designed to be used as an additional exit for the motorhome in case of an emergency. It can be easily identified by the red color of the handle. You open the egress window by lifting the handle and pushing outward on the window. The window can be closed by pulling the window closed and lowering the handle to the down or locked position.

*\*Open the egress window twice a year. The window tends to stick tight to the rubber seal. Opening the window every six months will reduce the likeliness of the window sticking to the seal.*

Liquified Petroleum (LP) Gas is heavier than air and will settle to the lowest point, which is generally the floor of your motorhome. The LP detector is also sensitive to other fumes such as hair spray, most of which contain butane as the propellant. Butane, like propane is heavier than air and will settle to the floor level where it will be detected. When this occurs, press the reset button to stop the alert sound for 60 seconds.

The other combustibles which will be detected include alcohol, liquor, deodorants, colognes, perfumes, wine, adhesives, lacquer, kerosene, gasoline, glues, most of all cleaning agents and aerosol can propellant. Most are lighter than air in their vapor state and will only be detected when the motorhome is closed up.

## LP DETECTOR



**CAUTION: This detector cannot alarm during the 3-minute warm-up cycle.**

When the power is first applied the Yellow LED will flash for 3 minutes, while the detector is stabilizing. At the end of that time the LED will turn Green indicating full operation. If the detector has detected unsafe levels of gas it will immediately go into alarm.

### Operation

Simply press the Test switch any time during the warm up cycle or while in normal operation. The LED should flash RED and the alarm should sound. Release the switch. This is the only way you should test your detector. The test feature checks the full operation of the detector.

### Test

The Red LED will flash and the alarm will sound whenever a dangerous level of propane or methane gas is detected. The detector will continue to alarm until the gas clears or the Mute switch is pressed.

### Alarm

#### Procedures to Take During an Alarm:

1. Turn off all gas appliances (stove, heater, furnace), extinguish all flames and smoking material. Evacuate, leave doors and windows open.
2. Turn off the propane tank valve.
3. Determine and repair the source of the leak. Seek professional help if necessary.



**CAUTION: Do not reenter the motorhome until the problem is corrected.**

Press the Test-Mute button when the detector is in alarm.

### Alarm Mute

1. The Red LED will continue to flash and the alarm will beep every 30 seconds, until the gas level has dropped to a safe level.
2. The LED will flash Green until the end of the Mute cycle.

3. If dangerous gas levels return before the end of the Mute cycle, the alarm will beep 4 times and return to phase 1.
4. After 2 minutes the detector will return to normal operation (solid Green) or resound the alarm if dangerous levels of gas remain in the area.

---

### Care of Your Detector

1. Vacuum the dust off the detector cover weekly, (more frequently in dusty locations), using the soft brush attachment of your vacuum.
2. Do not spray cleaning agents or waxes directly onto the front panel. This action may damage the sensor, cause an alarm or cause a detector malfunction.

---

## TOWING PROCEDURE

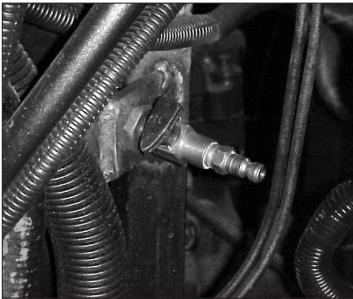

Open generator compartment to access air nipple.

It is recommended that if a towing company is called, they use a stinger (an arm that goes under motorhome and hooks to the front of the cross member). The towing company may need to locate the air nipple to release the air brakes. The air nipple is located on the roadside next to the generator and should only be used by towing personnel. Generally, if your motorhome ever needs to be towed, use the following instructions:

- Secure any loose or protruding parts if the motorhome is damaged.
- Inspect the points of attachment on the disabled motorhome. If the attachment points are damaged, select other attachment points at a substantial frame structural member.
- Never allow anyone to go under the motorhome while it is being lifted by towing equipment unless the disabled motorhome is adequately supported by safety stands.
- Do not tow the motorhome from the rear. Towing from the rear will cause the front tires and suspension to be seriously overloaded, possibly resulting in tire or front suspension failure. The rear frame extensions are not designed to withstand loads imposed by lifting the rear of the motorhome.
- If the rear wheels are disabled, place the motorhome on a flat bed trailer, or use a heavy duty dolly under the rear wheels and tow from the front of the motorhome.
- The drive shaft must be removed to protect the transmission.



**CAUTION: Failure to remove the driveline before towing may cause serious transmission damage.**

Make sure the tow truck can safely pull the weight of your motorhome. It is recommended that you give the towing company the weight of your motorhome when you call them. If your motorhome is going to be towed without a stinger do the following:

1. Wrap chains around both the A-arms or front axle on each side.
2. Pass the chains beneath the tow bar below the bumper.
3. Position a 6" by 6" timber between the ends of the main frame rails and the tow vehicle transfer plate, to maintain clearance of body parts.
4. Attach the safety chains, which are completely independent of the primary lifting device, to the main frame rails.
5. When the motorhome is under tow, allow enough room between the front of motorhome and the rear of the tow vehicle while turning corners.

## ***Towing Without A Stinger***

When using a rear hitch remember that your motorhome is intended for towing light loads. The motorhome is designed to be used primarily as a recreational vehicle, towing will affect durability and economy. Your safety and satisfaction require proper use. Avoid excessive loads or any other abuse. You should not use your motorhome to tow anything until your motorhome has been driven 500 miles (800 kilometers). The weight pushing down on the rear hitch must not exceed 400 pounds. We recommend weighing your motorhome as it will be operated to be certain that there is proper weight distribution. When weighing your motorhome be sure to take the passenger locations into consideration. The total weight of your motorhome, and any vehicle towed by it, must not exceed the GCW.

## ***HITCH -Using the Rear Hitch***



**WARNING: Any trailer being towed by your motorhome must have adequate brakes. Failure to follow these instructions will create a safety hazard and may result in an accident.**

## CHECKLIST- WINTER STORAGE

- **Plumbing Lines** - Drain and protect by filling with approved RV antifreeze.
- **Fresh Water Tank** - Drain.
- **Body** - Clean and wax. Oil locks and hinges. Repair roof seams as needed.
- **Countertop and Cabinets** - Wash with mild soap and water.
- **Curtains** - Remove and clean according to care specifications.
- **Windows** - To protect the interior fabric from fading, cover windows by pulling blinds, closing shades or using a separate cover such as a sheet.
- **Holding Tank** - Drain and rinse. Close valves. Add a small amount of antifreeze to keep valves and gaskets lubricated.
- **Drain Traps** - Pour RV antifreeze down all drains.
- **Batteries** - Add distilled water and recharge if needed. Disconnect the cables. Remove the batteries and store them in a cool dry place. Check and recharge as needed. Never park the coach where the battery door cannot be opened.
- **Refrigerator** - Clean and leave both doors propped open. Cover the exterior panels and roof vents.
- **Air Conditioner** - Remove the air filters and clean or replace.
- **Roof** - Keep clear of snow accumulation or damage may occur.

---

## CHECKLIST- OPENING THE MOTORHOME

If the motorhome was properly and carefully prepared for storage, taking it out of storage will not be difficult. The following procedure checklist assumes that you stored your motorhome properly. If you didn't, and extensive freeze damage or other serious deterioration has occurred, consult your dealer or an authorized service center for advice.

- Thoroughly inspect the outside of motorhome. Look for animal nests in the wheel wells or in other out of the way places.
- Remove all appliance vents, ceiling vents and air conditioning covers. Be sure all refrigerator openings are free of debris, insect nests, webs, etc.
- Open all doors and compartments. Check for animal or insect intrusion, water damage, or other deterioration.
- Check all chassis fluids levels: engine oil, engine coolant, hydraulic fluid reservoir, transmission oil, rear axle oil.
- Check the charge levels in the batteries. Refill with distilled water only and recharge as necessary. Reinstall the batteries if necessary.
- Be sure the cable ends and terminals are clean and free of corrosion.
- Be sure the engine instruments indicate proper readings. Start the engine allowing it to reach operating temperature. Shut the engine down. Check all fluids and fill as necessary.

- When the engine is running, check the operation of headlights, tail lights, turn signals, back-up lights, license plate light and emergency flasher. Operate the dash air conditioner. If the air conditioner does not work, or unusual sounds occur, have the system checked by a qualified air conditioner technician.
- Drain, flush, and sanitize the fresh water system as outlined in the water chapter (4). Inspect the drain hose for leaks. Replace if necessary.
- Operate all faucets and fixtures in the fresh water system.
- Check for water leaks at all joints and fittings. Repair if necessary.
- Check the 12 volt circuit breaker and inspect fuses.
- Operate all 12 volt lights and accessories.
- Install the new batteries in battery operated devices.
- Test the carbon monoxide, LP gas and smoke detectors.
- Check the monitor panel operation.
- Inspect the 120 volt electrical system which includes the power cord, converter, all outlets, and exposed wiring. If defects are found, refer to your dealer or an authorized service center.
- Start and run the generator.
- Operate the 120 volt appliances and air conditioners.
- Inspect the LP gas system and check for leaks. If the LP tank shows signs of rust or corrosion, have it inspected by a qualified LP technician.
- Operate each LP gas appliance. Observe all burner/pilot flames for proper color and size. In any case, have the LP gas regulator adjusted for proper pressure by a qualified technician.
- Inspect and clean the interior.
- Check the sealant around all roof and body seams and windows. Reseal if necessary.
- Lubricate all exterior locks, hinges, and latches.
- Check the windshield wiper blade condition. Check the wiper/washer operation.
- Wash and wax the exterior. Inspect the body for scratches or other damage; touch up or repair as necessary. Flush the underside thoroughly.
- Run through the operational checks for steering, brakes, engine and transmission. Operate the motorhome slowly during these checks to allow sufficient circulation of fluids and resetting of the components.
- If you choose, your dealer can double check your preparation and correct any defects or make any necessary adjustments.



**Prepare the generator for operation following the instructions in the generators Owner's Manual.**

**NOTES**

---

**CHAPTER 3**  
**APPLIANCES & EQUIPMENT**





**GENERAL  
INFORMATION**

This chapter covers operation and care of various appliances and types of equipment found in the motorhome. The motorhome is equipped with a refrigerator, cooktop, microwave, furnace, water heater, roof air conditioner and dash radio. Many appliances operate on AC or DC current, LP gas, or a combination of all three.



**Detailed information with CAUTION or WARNING instructions for the various appliances and electronics, other than what is found in this chapter, can be found in the manufacturer's owners manual.**



**WARNING: Before entering any type of refueling station make sure all LP gas operated appliances are OFF. Most LP gas appliances used in recreational vehicles are vented to the outside. When parked close to a gasoline pump, it is possible for fuel vapors to enter this type of appliance and ignite resulting in an explosion or fire.**

**Carbon monoxide gas may cause nausea, fainting, or death. Operating an LP gas appliance with inadequate ventilation or partial blockage of flue can result in carbon monoxide poisoning.**

**Do not store flammable liquids such as lighter fluid, gasoline, or propane in the outside refrigerator compartment.**

The refrigerator in the motorhome operates on a different principal than a standard household refrigerator. Knowing these differences should answer questions or solve problems that may arise. A standard household refrigerator uses a different type of refrigerant. The compressor will pump refrigerant vapor into a condenser where the heat from the refrigerant will be dissipated and the vapor will change to a liquid. The liquid refrigerant is pumped through a metered orifice or capillary tube at the evaporator. At this time, the refrigerant changes from liquid to a vapor. This change cools the evaporator. Air is then blown across the evaporator and into the interior of the refrigerator. This system is efficient as long as 120 volts AC is available, however this does not allow the freedom a recreational vehicle is designed to give. The recreational vehicle refrigerator uses a combination of fluids and gas for refrigeration; ammonia, water, sodium chromate and hydrogen gas. This combination is put into a pressurized cooling unit at approximately 350 psi. It is heated to a gaseous state, which then rises to the top of the cooling unit into a condenser where it forms droplets as it cools. As the vapor condenses it will "extract or absorb" heat out from the inside of the refrigerator. Using gravity, the droplets return through the absorber coils to the absorber vessel to start the process again. The cooling unit has specific guidelines that need to be followed for proper operation and insured longevity. Keeping these guidelines in mind should give years of faithful trouble free service.

**REFRIGERATION  
PRINCIPLES**

## Operation Specifics

The refrigerator operates from either LP gas or 120 volts AC electric. Controls are electronic which require the DC Voltage to be no higher than 15.4 vdc or lower than 10.5 vdc. The AC voltage limits are 132 vac (volts alternating current) maximum and 108 vac minimum. The refrigerator (from front view) needs to be leveled within 3 degrees side to side and 6 degrees front to back. Using a torpedo or bulls eye (fence post) level, place the level onto the freezer plate. The level should be within the circle by a half of a bubble. Generally, this is within comfortable living conditions. The heat source for the cooling unit is supplied by an electric heating element or an LP gas flame. The heat source, which is calibrated in BTU's (British thermal units), is concentrated to a specific area of the cooling unit. Operating the refrigerator in an "off level" condition will separate the sodium chromate and crystallize from the heat source. This blocks the recirculation action of the cooling unit, which causes accumulative and irreparable damage. The LP side of the refrigerator needs to be serviced yearly depending on use. The LP gas pressure should be checked as well. Over time the BTU rating can change, affecting the refrigerator's performance. Ambient air temperature and humidity can also affect its performance and function. LP gas operation at an altitude higher than 5,500 feet lowers the BTU rating, which affects the refrigerator's performance. If possible, switch mode operation to 120 volts AC electric while at higher an altitude



**WARNING: Do not use the refrigerator if there is an ammonia smell inside or outside of the refrigerator, or if a yellowish substance appears inside the box or in the outside access compartment. This can be an indication of a refrigerant leak. Contact an authorized repair facility.**

---

## Tips

- If possible, cool items first before putting them into the refrigerator.
- Keep the door shut. Think about what you want before opening the door.
- Try to allow the refrigerator 24 hours of operation before actual use. This will help it get a "head start" with the refrigeration process.
- A box of open baking soda will help absorb food odors. Wipe up any spilled soda.

---

## Refrigerator Controls

The refrigerator controls are DC (direct current) operated through an electronic circuit board. The refrigerator operating from heat, as described above, gets its heat source two different ways, either from an electric heating element or a flame from LP gas. Selection of desired mode operation and temperature is made by controls on the face of the refrigerator. For the refrigerator to operate the house batteries must be charged, the LP gas valve on, the water valve on (ice maker option only), and the refrigerator AC cord plugged in (located in outside refrigerator access door). If the controls don't light up, check the house batteries charge status or see if the 12 volt wires are plugged into the refrigerator's circuit board (outside in refrigerator access door).

**Alarm**

The refrigerator uses an audible alarm that will sound for the following reasons:

1. DC or AC voltage higher or lower than allowed specifications.
2. Refrigerator is set to auto mode and the 120 volts AC is discontinued.
3. LP gas mode fails to light initially or fails to light after a period of operation.
4. Door has been left open longer than 2 minutes.
5. The circuit board detects a failure resulting in a code being displayed.



**NOTE:** If the alarm sounds, note the code in the LED display and turn the refrigerator off to silence the alarm. Refer to the manufacturer's owners manual for the list of codes and their meanings.



**NOTE:** Keep the interior box temperature at or below 54 degrees. This will help reduce the possibility of food spoilage. Low interior box temperature causes the refrigerator to work harder, especially in hot and humid climates. Low box temperature may also add to quicker frost build-up.



**WARNING:** Make sure all flames are extinguished and the LP gas valve is off before refueling. LP gas and gasoline are highly flammable materials which can cause explosion, fire or death. Many states have passed laws regarding having the LP gas valve open while traveling. Know the laws for the particular state in which you are traveling.

The refrigerator doors are a positive lock style door closing with a "click". This will prevent accidental door opening while traveling. When storing the motorhome, the refrigerator doors have a storage position that locks the doors partially open. This will help reduce odor from mold and bacteria build-up. Use this feature. A completely closed up refrigerator in storage is a perfect habitat for molds and bacteria to grow. To use the storage feature, open doors approximately 1/2" and slide the latch into the cut-out of the strike plate.

**Doors**

**ON/OFF Button-** Depress this button to turn the refrigerator ON. Depress and hold this button to turn the refrigerator OFF.

**LED Display-** This screen is used for fault code display.

**MODE Button-** Pressing and holding this button will cycle the refrigerator through the different modes available: AUTO, AC, and LP modes. Release the button when the desired mode is displayed.

**TEMP SET Button-** Press and hold the button to select the desired temperature setting. Five settings are available, from COLD to COLDEST are available.

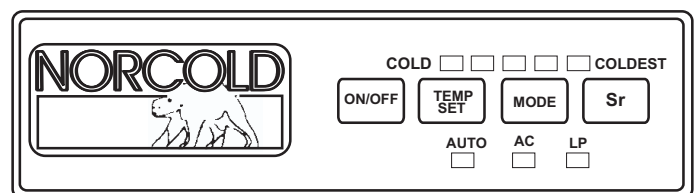
**Using the Refrigerator Control Panel**

Refrigerator Control Panel.

### **Manual Mode Operation**

This mode will lock the refrigerator into either LP gas or electric AC operation. Press and hold the MODE button until LP or AC is displayed. Release when the desired function is lit. The Alarm will sound and a code will be displayed if the function selected is interrupted or a failure occurs. Note the code and turn the refrigerator off to silence the alarm. Refer to the manufacturer's owner's manual for a list of codes and their meanings.

---

### **Auto Mode Operation**

This feature will automatically select 120 volts AC over LP gas operation. If 120 volts AC is available, it will use this source for operation until AC service has been discontinued. Once AC is discontinued, the alarm will sound and the refrigerator will automatically switch to LP gas operation. If the refrigerator fails to light, the alarm will sound and a code will be displayed.

Press and hold the MODE button until AUTO is displayed, release the button. Press and hold the TEMP SET button until desired temperature is displayed, release button. In AUTO mode, AC or LP will remain lit for 10 seconds upon initial start or when mode has changed.

---

### **Ice Maker Operation (Optional)**

The ice maker works from 120 volts AC only. The ice maker will start to function only after the freezer temperature is low enough. City water or the water pump must be on, and the valve (located in vanity cabinet) for the water supply line to the ice maker must be on. Pulling the metal arm(bail) down will turn the ice maker on. Pushing the arm up will turn the ice maker off.



**NOTE: Do not use the first one or two trays of ice if the refrigerator has been in storage. Ice cubes may have contaminates.**



**NOTE: Do not operate the ice maker without water pressure supplied to the refrigerator. This may damage the ice maker assembly.**

---

### **High Humidity Operation**

The refrigerator is equipped with a heating element located in the flapper on the left door (four door model), or in the door (two door model). The heating element is activated when the refrigerator is turned on to any mode to help prevent moisture build-up in high humidity conditions.

---

### **Cooling Unit Fans (four door models)**

The cooling unit is equipped with a pair of cooling fans to help pass air across the cooling unit. These fans start automatically and will be audible when in operation.

Turn the refrigerator off and remove all the items. Leave the drip tray under the cooling fins. **Do not** use heating guns, hair dryer or sharp objects to remove frost build-up, as these can damage the interior. Leave all doors open. Defrost time can be shortened using trays of warm water. Wipe off excess water using paper towels or cotton cloth.

## Defrosting the Refrigerator

Wipe using only cotton or paper towels. Products such as FORMULA 409, DAWN and FANTASTIC are acceptable cleaners. Do not use scouring pads or abrasive cleanser, as these can damage the interior finish.

## Cleaning the Refrigerator

The microwave oven is operated from 120 volts AC supplied by either shore power, the generator or the inverter. Microwaves heat food by using sound waves, generated at a very high frequency (2,450 MHZ), to agitate the water molecules inside the item being heated. The higher the water content is to solids, the faster the response or the shorter the cooking time. Inside the microwave is a turntable that rotates when the microwave is operating. This will help heat the food evenly. The turntable can be turned off if a baking dish or other large item is used. The microwave is designed to sit over a range or cook-top. When using the cooktop, use the microwave's two speed ventilation fan. The fan draws air in from the bottom of the microwave through a pair of grease filters, then discharges the filtered air out through a charcoal filter at the top. The ventilation fan is also thermostatically controlled and will be activated automatically by heat from the cooktop. The microwave offers many different features, some of which include varied cooking times with different power settings: automatic sensor cooking, a kitchen timer, Metric to American conversion chart (which includes temperature and weight), on screen programming help, childproof lockout, and auto defrost cycles. The screen can display one of three different languages.



## MICROWAVE OVEN

**(Optional)** The optional microwave/convection oven operates from 120 volts AC supplied by either shore power, the generator, or the inverter. The microwave/convection oven has the ability to cook food with heat like an electric oven, or preheat the oven with heat and cook with microwaves. Other features include the ability to cook with microwaves and convection at the same time, sensor cooking and a built-in broiler.



**NOTE:** When cooking in convection mode try to avoid using the inverter as the AC power source due to the high rate of battery consumption.



**WARNING:** If a fire flares up when using the cooktop, turn off the ventilation fan. The fan may spread the flame. If the ventilation fan has started automatically from a heated cooktop, it can not be manually turned off. Unplug the microwave cord from the 110 outlet to prevent the flame from getting up into the microwave and spreading the fire.

## Operation

The microwave operates on 120 volts AC power, which is supplied from either shore power, the on-board generator, or the inverter.



**NOTE: The microwave is for food preparation only. Do not use the microwave to dry clothes, newspapers, shoes or other items.**

### Safety Lock

The microwave comes with a safety lock feature. This feature prevents the oven from operating accidentally. To use this feature:

Press the CUSTOM HELP pad. Press the 1 pad. Press the START/TOUCH-ON pad. The oven is now locked. If any button is pressed the word LOCK will appear on the screen. The fan and hood light is still operational with the Safety Lock feature on.

To return the oven to normal operation:

Press the CUSTOM HELP pad. Press the 1 pad. Press the START/TOUCH-ON pad. The oven will resume normal operation.

### Setting The Clock:

- Press the STOP/CLEAR pad.
- Press the CLOCK pad.
- Enter correct time in sequence using the number pads.
- Press the CLOCK pad to begin time.



**NOTE: The clock is a 12 hour clock only.**

### Kitchen Timer

Press the KITCHEN TIMER pad. Using the number pads enter minutes and seconds, or 00 if no seconds. Press the START/TOUCH-ON pad to begin timer. Timer end will be signaled by one long beep.

Press the STOP/CLEAR pad to:

1. Erase if you make a mistake during programming.
2. Cancel the kitchen timer.
3. Stop the oven temporarily during cooking. (Press the START/TOUCH-ON pad to resume.)
4. Return the time of day to the display.
5. Cancel a program during cooking (touch the pad twice).

### TurnTable On/Off

- Press TURNTABLE ON/OFF pad to stop or start the turntable.
- Enter the cook time desired minutes and seconds.
- Enter power level desired.
- Press the START/TOUCH-ON pad.

### Hood Light

- To turn the hood light on or off, touch the LIGHT button.

### **Ventilation Fan**

Press the FAN HI/LO button once for high, twice for low and three times for off.

### **Microwave- Timed Cooking**

The maximum amount of cooking time is 99 minutes and 99 seconds. Be sure to enter minutes and seconds. If seconds are not desired, enter 00.

---

Press and hold the START/TOUCH-ON. The microwave pad will operate at 100 percent power until pad is released. This mode can be used for up to 3 minutes, and up to 3 consecutive cycles.

### **Microwave Cooking**

#### **One Minute Cook Times**

Press the MINUTE PLUS pad if one minute at full power is desired or to add one minute intervals to cooking time. The MINUTE PLUS pad must be pressed within one minute of closing the door, or during selected cooking time. For safety, the MINUTE PLUS feature will lockout if there is no microwave activity within one minute of closing the door. Use the START/TOUCH-ON pad to reset the one minute safety period.

#### **Microwave Cooking.**

To use 100 Percent Power, enter cook time by pressing the number pads. Press the START/TOUCH-ON pad to begin cook time. To use settings lower than 100 Percent Power, use the number pads to enter desired cooking time. Press the POWER LEVEL pad, and then use the number pad to select desired power level. Press the START/TOUCH-ON pad to begin cook time.

#### **Multiple Sequence Cooking**

If sequential cooking times with varied power levels are desired, press the POWER LEVEL pad and select desired power level. Use the number pad to enter cook time for the first interval. Press POWER LEVEL pad again, select desired power level, then enter cook time for the next time period. Press the START/TOUCH-ON pad to begin sequential cooking. The microwave can hold up to 4 sequential cook time periods. If full power is desired in any of the time periods, skip the power level step and 100 percent power is automatically selected.

#### **Keep Warm**

Press the KEEP WARM pad during cooking time to automatically keep food warm for up to 30 minutes after cooking time has expired. To use this feature after cooking time has expired or after the food has been removed, place the food back into oven and press the KEEP WARM pad.

#### **Defrosting**

Defrosting can be done on manual time selection or use the microwave's CompuDefrost.



### **Manual Defrost**

Press the POWER LEVEL pad. Select number 3 for defrost power. Enter desired defrost time. Be sure to stir or break food apart at regular intervals.

### **CompuDefrost**

The microwave has automated defrost programs for different foods and weights.

Press the CompuDefrost pad to enter this mode. Press CompuDefrost again to select between ground meat, steak or chicken. Use number pads to enter weight of food being defrosted. Press START/TOUCH-ON to begin defrost cycle.

### **Sensor Cooking**

The microwave has electronic sensors that sense moisture or humidity given off by the food during the cooking process. Electronic sensors will be affected if room temperature exceeds 95 degrees. To adjust the sensor cooking mode to allow for more or less cooking time, press the SENSOR COOK pad. Press the POWER LEVEL pad once to increase cooking time or twice to decrease cook time.

To use the sensor cooking mode, press the SENSOR COOK pad. Select the number or food desired from the library listed adjacent to the SENSOR COOK pad. Press the START/TOUCH-ON pad to begin sensor cooking.

---

## **Convection Cooking (option)**

The interior of the microwave produces heat just as it does in a regular oven. The convection cooking mode has special options, such as a broil mode, the ability to preheat oven by convection, and use of microwaves to complete cooking or to preheat



**NOTE: When using the convection oven feature, leave the turntable in place and do not restrict the rotation. This can damage the microwave.**

### **Cooking by Convection**

Press the CONVEC pad. Press the numbered pad with the desired cooking temperature. Press the numbered pads for desired cooking time. Press the START/TOUCH-ON pad to begin convection cooking.

### **Manual Broiling**

The Manual Broiling temperature is automatically preset to 450 degrees. Only the cooking time can be adjusted.

To use the broiler, press the BROIL pad. Enter amount of cooking time. Press the START/TOUCH-ON pad to begin preheating the oven. Four beeps will signal the end of the preheat cycle, and food can now be placed into the oven.

### **CompuBroil**

The CompuBroil cooking method has programs preset for common foods like hamburgers, steaks, chicken and fish. Temperature and time are preset depending on the food quantity. The amount of cooking time can be adjusted to fit particular needs. The POWER LEVEL pad will vary the preset cooking time. Press once for more time and twice for less time.

To use the CompuBroil feature, press the COMPUBROIL pad. Select the food number from the food library next to the CompuBroil pad. Enter the number of pieces being broiled. Press the START/TOUCH-ON pad to begin the preheat cycle. A series of four beeps signal the end of preheat cycle.

### **Automatic Mix Cooking**

This method combines both the convection oven and microwave at the same time. While in this mode, the microwave will use 30 percent power on HIGH/MIX and 10 percent power on LO/MIX. The convection temperature can be changed from 100 to 450 degrees. The default convection temperature is 325 degrees for both HIGH and LO mix.

To use this feature select either HIGH/MIX or LOW/MIX. Use the number pads to enter cooking time. Press the START/TOUCH-ON pad to begin the mixed cooking cycle.

### **CompuRoast or CompuBake**

CompuRoast and CompuBake can be used for food items ranging from pastries and cakes to roasts, chicken and pork. The temperature is preset for both functions. Only the cook times can be tailored for individual preference by entering into either the CompuRoast or the CompuBake mode. Press the POWER LEVEL pad once for more cooking time and twice for less cooking time.

To use either function, press the desired pad and enter the food type from list next to the mode used. Enter the food type being cooked by using the number pad. To use CompuBake, press the START/TOUCH-ON pad to begin preheat cycle. To use CompuRoast, enter the weight of item using the number pads. Press the START/TOUCH-ON pad to begin the preheat cycle. Four beeps will signal the end of the preheat cycle and the oven is now ready.

---

- Check the type of cookware being used to see if it is marked microwave or oven safe depending on the type of cooking being done.

***Tips***

- Gold paint or glaze may contain a trace amount of gold which is electrically conductive and is not compatible for microwave use. Hand-painted china commonly contains traces of metal.

- To test utensil for microwave compatibility, place the utensil in the microwave with an 8 oz plastic cup of water. Set the microwave at full power for one minute. Carefully, feel the utensil. It should not be hot. Make sure to

check the entire utensil.

- Cover food with a paper towel or upside-down plate to help keep food spattering to a minimum. Place a paper towel on the turntable to keep clean-up at a minimum. Use paper towels with microwave use only.
- Clean all spills or spatters before they dry.
- Food odors may linger inside oven. To help eliminate odors, combine the juice and the peel from one lemon, several whole cloves and 8 oz. of water in to a two cup bowl. Place in oven on high power, bring to a boil for several minutes, and let cool in the oven for several minutes.
- Some food wrappers may be foil lined. Check the wrapping carefully before cooking or heating. Small amounts of foil are acceptable if it is not wrinkled or near the sides of the microwave.
- Listen for popping or crackling noises. If sparks are seen while microwave is in use, discontinue use immediately. Remove the incompatible utensil before resuming operation.
- If the microwave screen is not lit, plug another electrical appliance into the same outlet the microwave was plugged into to verify AC power is present. If the test item works, contact an appliance repair facility to have the microwave checked.

### **Care and Cleaning**

The exterior of the oven is plastic and metal. The interior is metal. Do not use scouring pads, harsh or abrasive cleanser, chemical cleaners, or petroleum based thinners. These can damage the finish. Use mild soap and water with a damp cloth or paper towel to remove most stains or spills. When cleaning the touch pad, open the door to prevent accidental operation. Use mild soap and water with a soft cloth. Avoid using excess amounts of water on the touch pad. The turntable plate and oven racks are dishwasher safe.

### **Grease Filters**

Never operate the oven without the grease filters in place. This can damage the microwave. Grease filters should be cleaned at least once a month. To remove the filters, use the pull tab to slide the filter to the end of the opening and tip down. Soak the filters in the sink or in a dishpan filled with hot water and detergent.

**Do not** use ammonia or other alkali based products, as they may darken the filter material.

Agitate the filter and use a scrub brush to remove caked on grease.

Rinse the filter thoroughly and shake it dry.

Place the filter back into the opening, tip it upward and slide it to the end of the opening. Lock it into place. Be careful not to kink or warp the filter upon installation.

The stove uses LP gas only as a fuel source. The burners use a piezo type igniter. The cooktop should be used for cooking purposes only and not as a heating source. When the burner valve is opened the fuel source flows through the valve into the mixture tube. The fuel passes by a hole or venturi in the mixture tube, which draws air in with the fuel for a proper fuel/air ratio. The flame should have a blue appearance with a lighter blue defined flame at the burner head. A yellow flame or yellow tips indicates a rich fuel mixture, which can leave a black color or carbon on the bottom of a pot or pan.



Ignitor.

## COOKTOP

The cooktop will operate when the following conditions have been met:

### Operation

1. The LP gas valve on the LP tank is on, and the LP gas switch near the LP fill valve is turned ON.
2. The house battery cut-off switch at the entry door is ON.
3. To use the cooktop, open the desired burner valve and rotate the igniter knob clockwise at the left hand side of the stove.

The burner grate is attached to the cooktop cover by two spring clips located on the underside of the cooktop cover. The burner grate can be separated from the cooktop cover for cleaning purposes. Place a towel down onto the countertop next to the cooktop. Lift the cooktop cover up by the front corners, just high enough to clear the top of the burners. Pull the cooktop cover toward the front of the cooktop, and lift it away. Place the cooktop cover upside down onto the towel. Squeeze both of the grate spring clips to remove the grate from cooktop cover.

### Burner Grate



**WARNING: Do not leave burner valve(s) open while burner(s) are not lit. LP gas is heavier than air and will settle on the floor and “hide” in corners. Risk of explosion, fire, or injury can occur.**



**WARNING: IF YOU SMELL GAS**  
Extinguish all open flames and turn off the main gas supply. Liquid propane is highly volatile, highly explosive and extremely dangerous. Explosion, fire, property damage, injury or death can result. Propane is a “heavy” gas and will lay on the floor and “hide” in corners. Open all windows and doors. Do not touch any electrical switches. They may cause a spark which can ignite. Contact a qualified service center to have the problem correctly diagnosed and repaired before resuming operation.

## **Tips**

1. A yellow flame is an indicator of incorrect fuel/air ratio. Lowered BTU output and carbon build up can occur.
2. When cooking at an altitude above 5,000 feet, the flame may change appearance and the flame BTU output will be lowered. Allow extra cooking time.
3. Do not allow the tips of the flame to extend beyond pan or pot edge. When this occurs, heat is wasted and possibility of injury increases.
4. To help keep the underside of the cooktop clean, remove the cooktop cover by lifting the front corners and sliding the cover toward the front of the cooktop. Lift the cooktop cover away from the cooktop, while avoiding the burners. Carefully place strips of aluminum foil on the cooktop floor pan and under burners. Do not obstruct mixture tubes.

### **Care and Cleaning**

Regular cleaning with a soft cloth and a warm detergent solution is generally enough to keep the cooktop clean. Clean the cooktop when it is cool. Use a dry cloth or paper towel to clean spatters or spills when the surface is warm, before it gets baked on.

### **Porcelain Enamel**

Porcelain enamel is a type of glass fused on steel at a very high temperature. It is not extremely delicate but must be treated as glass. Sharp blows, radical surface temperature changes, etc., will cause enamel to chip or crack. Some foods, such as vinegar, lemon juice, tomatoes and milk, contain acids which can dull the finish of the enamel. To avoid dulling the finish, wipe up the spill before it is baked on. Remember, the surface is glass and must be given consideration when cleaning. Steel wool and coarse, gritty cleanser will scratch or mar the surface. Any gentle kitchen cleanser powder or grease cleaner will be suitable. For further information on care and maintenance of the porcelain, call "Hopes Cultured Marble Polish" at 800-325-4026.

---

## **AIR CONDITIONER (ROOF)**

The roof air conditioners operate from 120 volts AC only, either by shore power or the generator. Operation is controlled by a 12 volt DC wall thermostat. The electronics in the wall thermostat send a signal to the roof air conditioner's (a/c) circuit board. The circuit board controls the desired roof "a/c" functions. The refrigeration process in the roof "a/c" is primarily the same as the dash air conditioning or a household type refrigerator. It functions as an enclosed system. The refrigeration process repeats in a cycle. The refrigerant is drawn into the compressor where it is heated from compression. The high pressure vapor is sent to a condenser where the heat is expelled into the atmosphere. The vapor leaves the condenser as a high pressure liquid. This liquid is forced into a metered capillary tube, and then into the evaporator or low side pressure. The refrigerant changes from liquid form to a vapor as the heat is extracted. The vapor is drawn back into the compressor to start the cycle again.



**NOTE: Air conditioning systems will freeze the moisture in the air depending on the humidity content. Under high humidity conditions it is recommended to leave the HIGH/LOW switch to the HIGH position.**

### Operation

The roof air conditioner will operate only when the following needs have been met:

1. 120 volts AC from either shore power or the generator is supplied.
2. The battery cut-off switch is in the ON position and house batteries are charged.

### Thermostat Operation

The thermostat operates the roof air conditioner and the furnace.

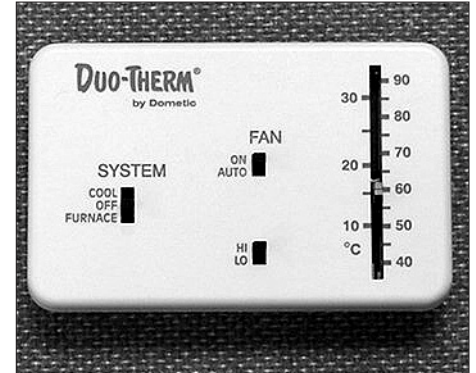

*Use this wall thermostat for the furnace/roof air.*

### ROOF AIR OPERATION

**FAN ONLY-** Move the FAN switch to the ON position. Use the HIGH or LOW switch to set desired fan speed. Set the thermostat to desired temperature.

**COOL-** Move the SYSTEM switch to COOL. Move FAN switch ON. Set the thermostat to the desired temperature. Use the HIGH or LOW switch to set desired fan speed.



**NOTE: If the motorhome is equipped with the optional second roof “a/c” for the bedroom, the thermostat operation is the same; however, the SYSTEM FURNACE position is non-functional.**

The furnace and its related components are 12 volt DC operated. It uses LP gas as its fuel source. Electronic circuitry (automatic ignition) is used to ignite the burner. The furnace uses outside air for the burner combustion, and exhaust is expelled through the outside vent. Inside air is drawn into the furnace and blown across the internal heat exchanger. Heated air is then discharged through a plenum which runs, front to rear, in the floor of the motorhome. A warm air discharge is incorporated to heat the motorhome’s holding tanks. Operation is as follows: The wall thermostat sends a signal to the front roof air conditioner circuit board, which closes a relay. This relay sends an electrical signal to the furnace to begin the ignition cycle. There is a small time delay before the blower motor begins. Once the blower motor attains a predetermined speed, it will close the air prover or sail switch. The sail switch, which is now closed, sends the electrical signal through a high temperature protection switch, then to the automatic ignition circuit board.

### FURNACE

After the thermostat is satisfied, the gas valve closes and extinguishes the burner. The blower motor stops approximately 45 seconds later.



**NOTE:** The automatic ignition circuit board will attempt to light the burner three times before the ignition board will go into “lock-out”. If the burner does not light, the furnace blower motor will continue to run and the wall thermostat will have to be cycled off.



**WARNING: IF YOU SMELL GAS**

Extinguish all open flames and turn off the main gas supply. Liquid propane is highly volatile and extremely dangerous. Explosion, fire, property damage, injury or death can result. Propane is a “heavy” gas and will lay on the floor and “hide” in corners. Open all windows and door. Do not touch any electrical switches. They may cause a spark which can ignite. Contact a qualified service center and have the problem correctly diagnosed and repaired before resuming operation.



**NOTE:** Do not store any items or materials in the furnace area. Restricted air flow may hamper furnace operation leading to failure and/or fire hazard.

---

## Operation

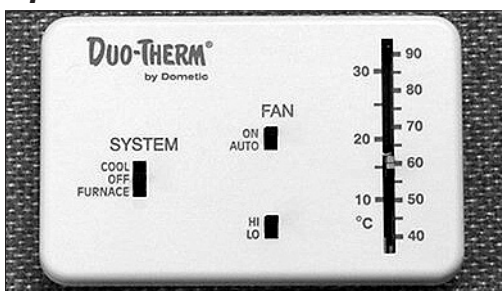

Wall Thermostat.

The furnace will operate when the following conditions have been met:

1. The LP gas valve on the LP tank is on, and the LP gas valve at the furnace is on.
2. The ON/OFF switch next to the LP gas fill valve is turned to ON.
3. The motorhome’s house batteries are charged.
4. The battery cut-off switch at the entry door is in the ON position.

---

## Using the Furnace

- Set the SYSTEM switch to FURNACE.
- Set the FAN switch to AUTO.
- Set desired temperature.



**NOTE:** When washing the exterior of the motorhome, avoid a direct stream of water into the outside furnace vents. This can damage the furnace.

---

## Tips

- After storage, the furnace may produce a musty smell during the first couple of cycles.
- Operating the furnace at an altitude above 5,000 feet reduces the BTU output due to air/fuel ratio.
- The furnace will periodically need to be serviced by a qualified technician. If the furnace exhibits unusual symptoms or noises, or has an unusual odor when operating, have the furnace checked or serviced.
- If the furnace fails to light. Make sure the LP gas supply valves are open, and the

LP gas switch is turned ON.

- Make sure the battery cut-off switch at the entry door is ON.
- The furnace will not light if the blower motor is not spinning to its specified speed. This may be due to a low house battery charge condition. Hook-up to shore power and start the generator or main engine to charge the batteries.
- **If you smell gas and the blower motor is spinning, do not attempt additional furnace operation. This may result in an explosion, fire or personal injury. Contact a qualified technician.**

If the blower motor does not spin and the necessary power requirements have been met, use a screwdriver or coin to open the furnace access panel outside of the motorhome. Make sure the ON/OFF switch is ON and the circuit breaker is pushed IN.

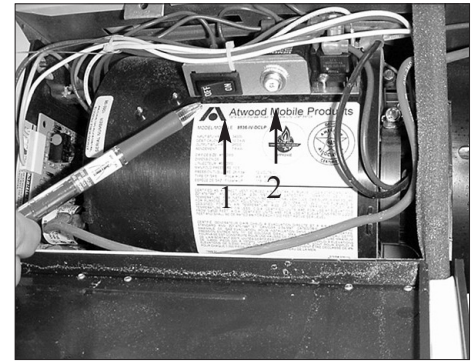

Furnace:

1. Off/On Switch.
2. Resettable Breaker.

The water heater in the motorhome will heat water using two different methods. The first method is 120 volts AC, supplied either by shore power or the on board generator. The second method is LP gas. The 120 volt AC uses a heating element like those found in a house style water heater. The 120 volt AC method is efficient if shore power is available. The LP gas incorporates the use of an automatic ignition circuit board operated by 12 volt DC. The water temperature is controlled by two thermostats. One is for the 120 volt and the other is for the LP gas. The temperature is preset by the water heater manufacturer. Water is pumped into the bottom of the water heater tank where it is heated and discharged out of the top of the tank upon usage. For easy winterization, the water heater is equipped with a by-pass valve, safety features include a temperature pressure relief valve. The water heater has an aluminum clad tank, an anode is not necessary.

## WATER HEATER



**NOTE: The automatic ignition circuit board will make three attempts to light the burner. If the burner does not light by the third attempt, the ignition circuit board will go into “lock-out.” Cycling the on/off switch will reset the ignition board.**



**NOTE: Do not operate the water heater by either function without water in the water heater tank. This can damage the thermostats and the electric heating element.**

Before using the water heater, purge all trapped air from the water system. To purge the air and pressurize the system, fill the fresh water tank by using the on board water pump or hooking up to city water. Check the tank for any obvious water leaks. Once the system is pressurized, turn the hot and cold valves on for each water faucet, one at a time, inside and outside of the motorhome. Run each faucet until a steady stream of water with no air bub-

***Before Using  
the Water Heater***



bles or air pockets is present. The water heater does not need to be operating while this is being done.



**WARNING: IF YOU SMELL GAS**

Extinguish all open flames and turn off the main gas supply. Liquid propane is highly volatile and extremely dangerous. Explosion, fire, property damage, injury or death can result from fumes. Propane is a heavy gas that may lay on the floor and “hide” in corners. Open all windows and door. Do not touch any electrical switches. Electrical switches can spark and may ignite fumes. Contact a qualified service center to have the problem correctly diagnosed and repaired before resuming operation.

---

**Operation**

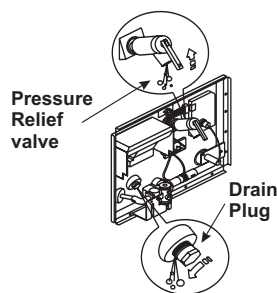

Relief valve, drain plug.

The water heater will operate when the following conditions have been met:

1. 120 volts AC has been supplied either from shore power or the generator.
2. The LP gas valve on the LP tank is ON and the LP ON/OFF switch next to the LP tank fill valve is in the ON position.
3. The battery cut-off switch at the entry door is ON.
4. The house batteries are charged.

---

**Using the Water Heater on LPGas**

Make sure the LP gas is turned on.

Go to the monitor panel located in the overhead cabinet above co-pilot seat. Turn the water heater switch to the the ON position. The water heater will make an audible “roar” from the burner when ignited. The indicator light will illuminate briefly then go out when the water heater is lit. The indicator light will glow steady when the ignition cycle has gone into “lock-out.”

---

**Using the Water Heater on 120 AC**

- Have either shore power or the generator supplying AC voltage.
- Turn on the RED piloted switch located above the vanity sink.

---

**Tips**

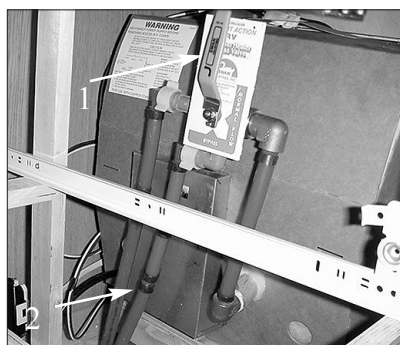

1. By-pass.  
2. Manual Off/On 110 Switch.

- Turn off water heater when not in use to conserve LP gas.
- The water heater tank capacity is ten gallons. When running the shower, conserve the heated water by shutting the shower water off when not in immediate use.
- Use care when adapted to 30 amp shore service. The water heater element, when in operation, will use approximately 12 amps. It may be necessary to operate appliances in sequence.
- The temperature and pressure (T&P) safety relief valve on the outside of the water heater is set to open at 210 degrees or 150 psi. When water temperature and pressure reach these settings, the valve may drip until the pressure

has dropped. Avoid opening the T&P valve manually as it may continue to leak. The valves can be purchased from most hardware stores.

### ***If the Water Heater Fails to Function under Gas Operation***



**WARNING: Before beginning any service or work on the water heater make sure the LP gas is turned off, the 120 volt AC source has been disconnected, and the 12 volt DC source has been disconnected. Failure to do so can result in explosion, fire or injury.**

- If water heater fails to light, check the outside burner tube for obstructions. Spiders make nests in the burner tube.

- If the indicator light on the monitor panel does not light and the water heater does not light, make sure the battery cut-off switch at the entry door is on, or check for a blown fuse in the house distribution panel.

- If the 120 volt RED piloted switch at the vanity is lit, but there is no hot water, check the ON/OFF switch (located just above where the AC electric cord comes out of the back of the water heater service box).

- If the 120 volt RED piloted switch does not light, check the AC source, breaker, shore cord connection or transfer switch.

### ***If the Water Heater Fails to Function Under Electric Operation***

If the motorhome was not ordered with an optional washer/dryer, it will have a washer/dryer preparation package installed from the factory. The washer/dryer “prep” package includes the following items:

1. Color coded water supply lines, a red line for hot, a blue line for cold.
2. An 1 1/2” waste water drain line with threaded cap, p-trap, and an automatic vent cap. This will drain the waste water into the grey water holding tank.
3. A 120 volt receptacle located in the above compartment.

### **WASHER/DRYER PREPARED**

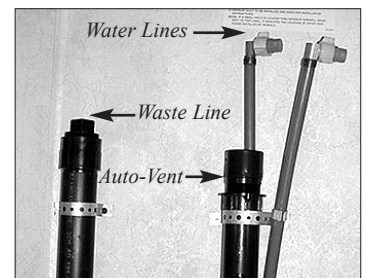

*Washer Dryer Prep.*



**NOTE: Sidewall dryer vents are not part of the prep package. If a sidewall vent is to be installed, be sure it is properly sealed to the sidewall.**

If a washer/dryer is to be installed at a later date, follow all the manufacturer’s installation instructions. Listed here are further instructions which should be adhered to for safe and reliable operation:

Do not connect the clothes dryer exhaust duct to any other duct, vent or chimney.

Do not terminate the exhaust duct beneath the motorhome.

Be sure to use proper length fasteners when attaching exhaust vent to exterior sidewall. Stainless steel fasteners are best suited for this as they will not rust.

If the cabinet or closet in which a washer/dryer is installed does not have vented/louvered doors, the manufacturer’s installation instructions may require installation of vented doors or vents to be installed in the doors. This is for sufficient circulation of drying air.

## WASHER/DRYER

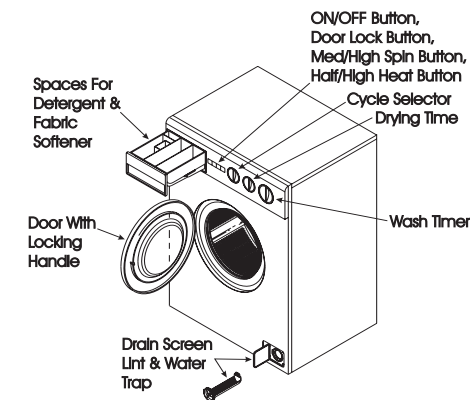

Washer/Dryer.

This appliance is an automatic washer with a capacity of up to 10 lbs. (4.5Kg) of dry clothing. It is front loading, with an extra large door opening for easier access. It has 5 wash cycles in addition to extra rinse and extra spin cycles.

- The Washer/Dryer operates on 120 VAC.
- To operate the Washer/Dryer you will need to be plugged into shore power or have the generator running.
- The Washer/Dryer can be operated while driving down the road. The generator will need to be running and the water pump will need to be on. Make sure the gray tank will have enough room for the rinse cycle.
- The Washer/Dryer water use will be approximately 16 gallons of water per load.

### Operating Instructions

Before using the washer for the first time, wipe the inside and outside with a damp cloth to remove any travel dust that has accumulated. We recommend operating a rinse cycle to rinse out your washer. Front load horizontal axis washing machines require less detergent. Soap suds line should not exceed the halfway point of the glass door.

- Sort and pre-treat clothes (specific directions under sorting).
- Add the measured amount of detergent suggested by the package directions (maximum 2 tablespoons).
- Load the clothes loosely into the washer. Close the washer door.
- Turn the cycle selector knob to the desired temperature setting.
- Decide which washing cycle you wish to use. Turn the timer knob clockwise to the desired wash setting.
- Select High or Medium spin (only for regular washing).
- Press the push button ON.

After the cycle is complete, wait 2 minutes for the door lock to release before attempting to open the door.



**WARNING: Do not wash or dry articles that have previously been cleaned, washed, soaked, or spotted with gasoline, dry cleaning solvents or other flammable or explosive substances. They give off vapors that could ignite or explode. Do not add gasoline, dry cleaning solvents or other flammable or explosive substances to the wash water. Do not use heat to dry articles containing foam rubber or similar textured, rubber-like materials. Clean the lint screen if applicable (located on the back of the washer in the top left corner) after each use, and keep the area around the exhaust opening and adjacent areas free from the accumulation of lint, dust and dirt.**

## **Cleaning the Drain Screen**

The removable drain screen which protects the pump from lint and foreign matter needs to be cleaned periodically. How often will depend on the type of clothes that you wash. Cotton articles cause more lint to collect than nylon articles. Under no circumstance should the drain screen be removed while the machine is full of water. To clean the drain screen open the service door by pressing on the left hand side. Place a cloth or shallow tray under the drain screen housing, as a small quantity of water may run out. You may find it helpful to first set the machine to spin then remove the drain screen. This procedure reduces the amount of water released. Turn the drain screen counterclockwise and pull the drain screen out. Clean the screen to remove any dirt and lint. To replace the screen slide it back into the housing and turn it clockwise to secure. Close the service door.

To winterize your Washer/Dryer please follow the instructions below to avoid damage to your unit due to freezing:

1. With the unit off, remove the wash filter. This will allow the water remaining (in the pump and drain hose) to be evacuated. Replace the filter.
2. Close the inlet shut-off valve located at the manabloc water system, and open the low point drains to drain all water.

### **If antifreeze is being used in the system follow these instructions:**

1. When putting antifreeze into the water system of your motorhome, set the washer to a warm/warm fill setting and allow water to flow into the unit until the antifreeze is detected.
2. Slowly advance the timer to a rinse cycle and allow the water to flow for 10 seconds. Advance the unit to a spin cycle to remove the majority of the water from the unit.
4. With the unit off, remove the wash filter from the unit. This will allow the water remaining in the pump and drain hose to be evacuated. Replace the filter.
5. Any water remaining in the unit should contain antifreeze and be protected from freezing.



**NOTE: When placing the unit back into service allow the unit to operate for one complete cycle before doing laundry to ensure all antifreeze has been purged from the unit.**

As you use the Washer/Dryer, occasionally wipe the exterior of the cabinet with a damp cloth or sponge; wipe it dry with a soft cloth. Do not use polish on plastic trim. Clean the interior with 1 cup of chlorine bleach mixed with 2 cups of granular detergent. Run the washer through a complete cycle using the hot water. Repeat the process if necessary. Remove hard water deposits using only cleaners labeled as washer safe. Wipe the inside of the Washer/Dryer door with a soft cloth to remove any moisture. Periodically, a

## **Winterizing Your Washer/Dryer**

## **Cleaning the Washer/ Dryer**

thin coat of paste wax should be applied to the inner door; especially to the area which is immediately next to the door window. This will protect the door finish from laundry spills and discoloration.



**NOTE:** Should the washer/dryer need removal for service needs care should be taken as the washer/dryer weighs approximately 185 lbs. Proper accommodations should be made to avoid risk of injury.

## TELEVISION ANTENNA

The television antenna is a manual crank up style antenna with built in electronics which uses 12 volts DC to “boost” signal strength. Weak or fuzzy signals can be amplified by turning on the boost switch in the passenger front overhead cabinet. The antenna and booster work together to provide the best possible picture for most situations. Certain conditions occur when no amplification is needed, and in fact, may make the picture worse. The television station will send a signal that resembles waves, like rings from a rock thrown into a still pond. The radiating television signal can bounce back from an object such as a mountain. The antenna will receive a signal from the initial pass, then receive an additional signal from the rebound resulting in a split or double image. In this case the picture may be improved by no amplification, or even by lowering the antenna.

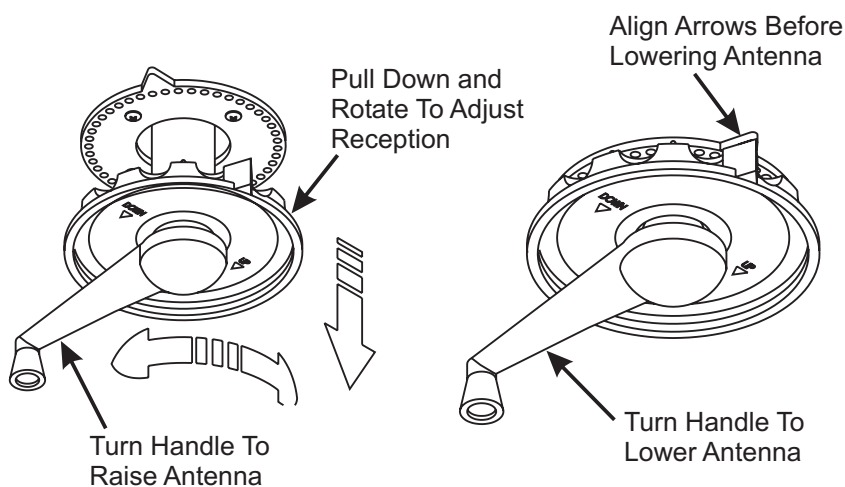

*Antenna Manual Crank.*



**NOTE:** Do not move the motorhome with the antenna in the raised position. The antenna can be damaged by tree limbs or wires.



**WARNING:** Before raising the antenna, make an outside visual inspection for any obstructions or overhead electrical wires. Damage to the antenna, severe shock, personal injury or death can occur.

• **To Raise The Antenna:**

Rotate crank handle clockwise to raise (approximately 14 1/2 turns). Pull down on outside directional wheel and rotate antenna until the best picture is viewed. The directional wheel is spring loaded.

• **To Lower The Antenna:**

Pull down on the directional wheel and align arrows together. Rotate crank handle counter clockwise, lowering antenna fully into the cradle. Make an outside visual inspection to ensure the antenna is properly stowed.

• **Boost Operation:**

To boost the antenna signal to the TV or VCR, use the boost switch located above the VCR in the front overhead cabinet. Turn the switch to the ON position. Turn the boost switch OFF when not in use.

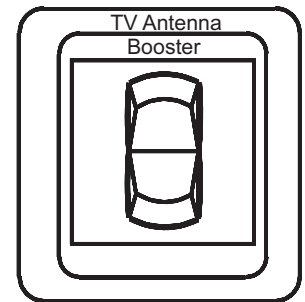

**CABLE TV AND TELEPHONE HOOKUPS**

The motorhome is equipped with cable TV and telephone hook-ups, located in the electrical service center. For convenience, there are auxiliary outlets located at the co-pilot seat and in the second bay passenger side, outside. These connections are set up so that a TV, phone or laptop computer can be used. The two auxiliary TV outlets are fed by the coax, which also goes to the rear TV. When using these outlets, follow the instructions given in the video selector box section.

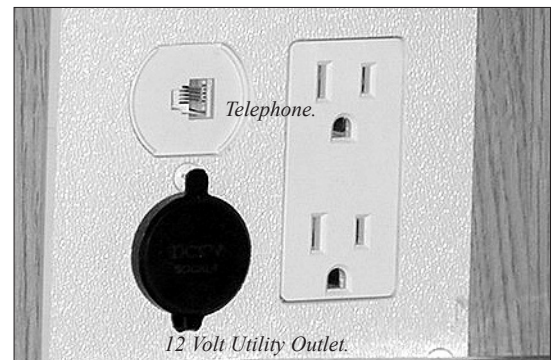

The motorhome is prewired for a roof mount DSS system. A 3/4" flexible conduit is provided, which runs from the front overhead to a spot marked on the roof, located approximately two feet adjacent to the co-pilot seat. A telephone hook-up is also available for Pay Per View.

**DSS PREWIRE**

The motorhome is equipped with a video selector box located just above the VCR. The selector box receives video and audio signals from three different sources, the roof mounted antenna, shore cable (auxiliary), or the VCR. The video selector box directs the signals to either the front or rear TV, and directs the signal from shore cable or the roof mounted antenna to the VCR. The selector box switches are divided into

**VIDEO SELECTOR BOX (OPTIONAL)**



three groups: TV1 (front TV), TV2 (rear TV), and the VCR. Both the TV1 and TV2 button groups perform the same functions. Example: To watch the front TV (TV1) from the antenna, depress the ANT button in the TV1 group. This will direct the signal from the antenna to the front TV.

**To Watch the front TV:**

- Using the antenna, depress the ANT button in the the TV1 group.
- Using the shore cable, depress the AUXILIARY button in the TV1 group.
- Using the VCR, turn the TV to channel 3 and depress the VCR button in the TV1 group.

**To Watch the REAR TV:**

- Using the antenna, depress the ANT button in the the TV2 group.
- Using the shore cable, depress the AUXILIARY button in the TV2 group.
- Using the VCR, turn the TV to channel 3 and depress the VCR button in the TV2 group.



**NOTE: When watching TV by using the VCR, such as playing a tape, make sure the TV is tuned to channel 3.**

**Using the VCR (optional):**

- With the antenna, depress the ANT button in the VCR group.
- With the shore cable, depress the AUXILIARY button in the VCR group.

---

**Tips**

1. If the picture is weak and the antenna boost is working, try moving the motorhome a few feet forward or backwards.
2. If it is weak or has no picture, check the video selector box to make sure the proper mode button has been selected.
3. If the signal is still weak, it may be a shorted or open coax. The coax cable is made up of two conductors. A center conductor, which is usually copper; and the ground, which is woven or braided aluminum. There is insulating material that separates the two conductors known as the die-electric. The ground and center conductor are to remain separate from one another. When installing a metal end onto the coax cable, use care so that none of the woven ground strands come in contact with the center conductor. A continuity tester is used to test for a suspected bad coax wire run. Unscrew both ends of the suspected bad coax run, and use the continuity tester to check between the center conductor and outside threaded ring. If continuity is present, the coax is shorted. To test for an open connection of a particular coax run, touch each end of the coax's ground or center conductor using the tester leads. Continuity should be present. For proper operation there should be continuity from one end to the other of both the ground and center conductor. No continuity should be between the ground and center conductor. Though damage does not usually occur from a shorted or open coax cable, picture quality is compromised.

The motorhome is equipped with a remote control, color television located above the pilot seat. The outlet for front TV is controlled by the ignition switch so that the front TV can only be viewed while the vehicle is at rest. The TV operates from 120 volts AC power only, which can be provided by shore power, the generator, or the inverter. Viewing time of the front TV from the inverter depends on the state of charge of the house batteries and any additional 12 DC lighting being used.

### **Front Television & Cut-Out**

The VCR and bedroom television operate from 120 volts AC only, which can be provided by shore power, the generator or the inverter. Use the instructions given in the video selector box section to use these components.

### **VCR & Bedroom Television (optional)**

The dash radio is a tuner and a compact disc player. It holds up to eighteen preset FM stations and six AM stations. Other features are an attenuate mode, loudness control, a clock, and autoseek tuning. The compact disc player features are fast forward and reverse, random track play, repeat and pause. The radio power can be turned off from two different locations. One switch is located in the center dash panel and the other is in the bedroom.

### **DASH RADIO**

#### **Operation**

- Turn on the house battery cut-off switch located at entry door.
- To turn radio on: Push the SRC (source) button.
- To turn radio off: Push and hold the SRC button.
- To change between tuner and CD mode: With CD installed push the SRC button.
- Volume: Use the ▲ ▼ to increase or decrease volume.



*Dash Radio.*

**A/M or F/M:** Use these buttons to select the desired band. Push F/M 1, 2 or 3 to scroll through the three sets of presets.

**Stations:** Use the ◀ ▶ to change the station. Use the AUTO/MAN button for desired preference.

**Attenuate or Loudness:** Press the ATT button to attenuate, or press and hold the ATT button for loudness.

**MODE:** Use to: **1.** Set the clock. **2.** Change Left to Right speaker balance. **3.** Fade sound Front to Rear.

**Clock set:** Push and hold the MODE button until screen changes then use the ◀ or ▶ to locate clock. Push and hold either A/M or F/M until hour changes then use the ◀ or ▶ to change the minutes.

**Fade or Balance:** Press the MODE button. Use A/M or F/M to locate bass or treble, balance or fade. Use the ◀ or ▶ to change settings.



## Tips

1. If the radio does not function, check the house battery cut-off switch to make sure it is ON. Check either of the radio power switches at center dash panel or in bedroom.
2. If the radio acts erratic, depress the reset button located in between the ATT and the 1 button.
3. The LCD display may become difficult to read at temperatures at or below 41 degrees Fahrenheit.

## GALLEY AND BATHROOM FANS

The galley fan is a 3 speed fan with a 0 or off position. The fan is bi-directional for intake or exhaust air movement. The fan lid is manually operated by a crank handle located on the fan. When the lid is partially raised, the fan motor will be allowed to operate.

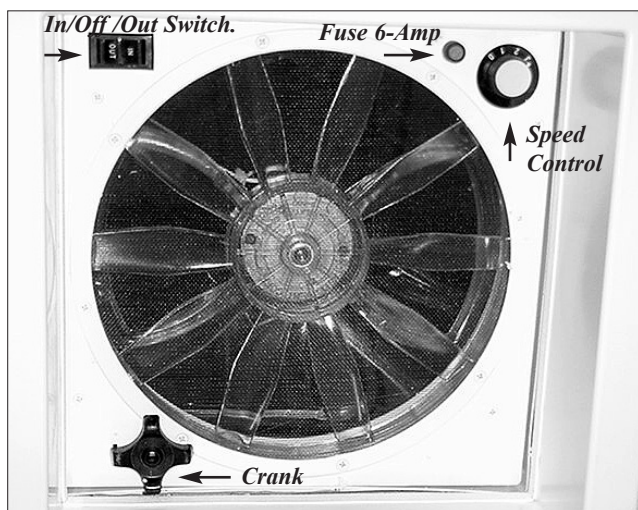

### To Operate The Fan:

- Crank lid open to desired height.
- Set fan direction I=IN or O=OUT.
- Set desired fan speed:

**O = OFF.**

**1 = LOW.**

**2 = MEDIUM.**

**3 = HIGH.**



**NOTE: Let fan come to a complete stop before changing fan direction.**

## Tips

1. To help keep condensation from accumulating, open the vent fan lids slightly. This will help the air to circulate. Condensation is naturally occurring from the fluctuation of interior and exterior temperatures, humidity and dew point changes, and from cooking or large amounts of water boiling on the cooktop. Shower usage is another culprit of condensation.
2. If the fan fails to operate, check for a blown fuse either in the domestic fuse panel or the 6 amp fuse on the fan.

- The bathroom fan is a single speed exhaust fan only. The lid is a manual crank up style.
- Use crank to open fan lid to desired height.
- Use push button switch to turn fan on or off.

## Bathroom Fan

The motorhome is equipped with a sliding step well cover that is extended and retracted by use of a dual action air cylinder. The air cylinder is controlled by an electrically operated air valve. The air solenoid known as a “MAC” valve receives air pressure from the front air tank. The “MAC” valve will direct the air pressure to either side of the dual action air cylinder, moving the stepwell cover in or out. The stepwell cover will not operate without sufficient air pressure (approximately 60 psi).



**CAUTION: The stepwell cover is under air pressure. When operating the stepwell cover be sure there are no pets, shoes or other obstructions in the stepwell area. Do not operate the stepwell cover while standing in the stepwell area.**

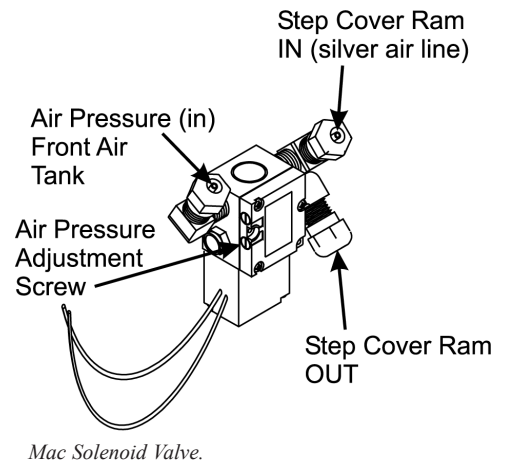

## STEPWELL COVER

## Adjustments

The “MAC” air valve is located in the front of the motorhome, behind the generator door mounted to the frame. The easiest way to identify the location is have someone operate the stepwell cover with the generator door open and listen for the release of air. The “MAC” air valve has two adjustment screws. The adjustment screws regulate the air flow to either side of the air cylinder. Adjusting the screws will affect the speed at which the air cylinder moves in or out. Clockwise adjustment on the screw will decrease air flow, and counterclockwise adjustment on the screw will increase the air flow.

## ENTRY STEP

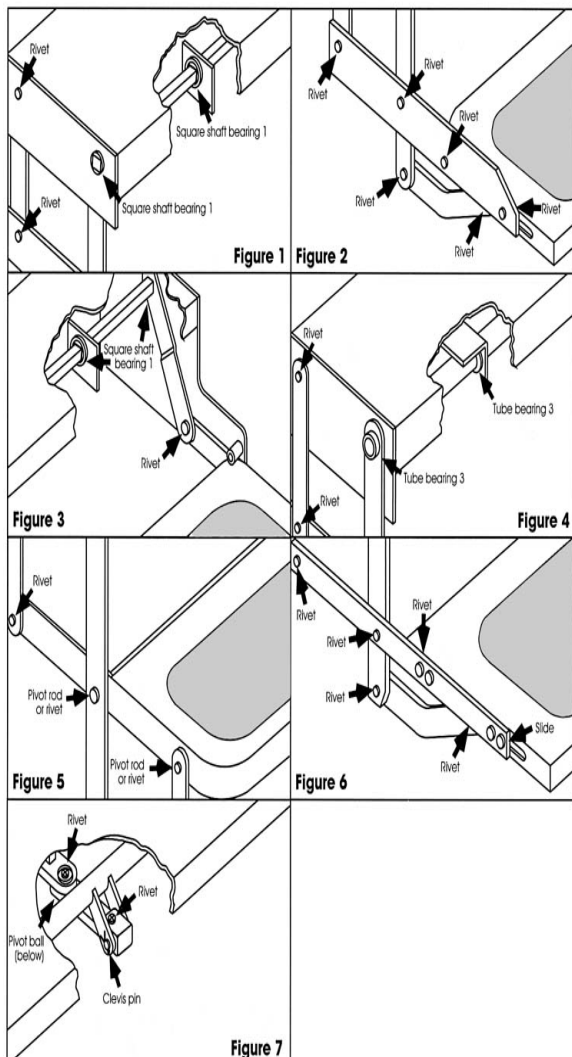

Entry Step Lubrication Points.

The entry step features amber lighting under the step, automatic retraction with the ignition key in the RUN position, and a last out benefit. Located to the left, just inside the entry door, is the step switch. Three fuses are used to operate the step. The fuses for the switch, step motor and ignition signal are located outside in the front fuse bay, inside the front distribution panel.

### Step Operation

- Turn the step switch on.
- Close the door. The step should retract and lock in the “up” position.
- Open the door. The step should extend and lock in the “down” position with the under step light on.
- The step is equipped with a power switch. Turn it off. The step should remain in the extended position with the under step light off when the door is closed. Turning off the power with the step retracted will hold the step in a retracted position as well.
- With the power switch off, the step extended, the entrance door closed and the ignition turned on, the ignition override system will go into effect and the step will automatically retract.
- Turn the ignition off and open the door. The step will extend and lock in the “down” position. This is the “last out” feature. When the ignition is on, the step will always activate with the door movement, regardless of the power switch position.

### Maintenance & Lubrication

Clean all mud, salt, and road grime from the step before lubricating. Lubricate all moving parts (bearings, pivot points, slides, clevis pin, and drive linkage ball) every 30 days with a good quality heat and moisture resistant penetrating grease. Kwik Lube Spray Grease is specially formulated to lubricate Kwik Electric Steps and is recommended for lubricating all moving parts. Refer to the picture on the left.



**NOTE: Silicone lubricates and WD-40 are not recommended as they have a tendency to evaporate and dry the mating surfaces which leave them vulnerable to the elements.**

**Swivel Seat Operation**

- To adjust the seat forward or backward use lever A.
- To adjust the seat backrest use lever C.
- To swivel the seat use lever B. The armrest may need to be in a vertical position.

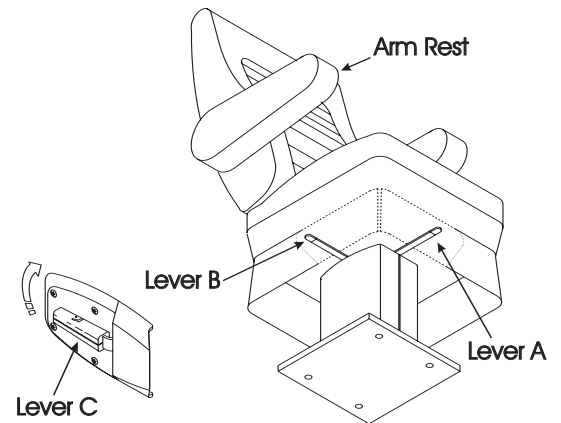

The sofa will convert easily into a bed. The sofa comes with removable side armrests and safety belts.

**SOFA SLEEPER****To Convert The Sofa To Sleeper:**

- Remove detachable side armrests.
- Lifting from the center of sofa just below the seat cushions, raise the sofa seat base until seat base and backrest form a V shape. Push down on seat base until the seat base and backrest are flat.
- Fold seat belts out of the way.

**To Return To Sofa**

- Lift the seat base up until seat and back rest are in a V shape, then push down on seat base.
- Install armrests back into the slots.

- The booth dinette easily converts into a bed.
- Lift seat cushions to an angled vertical position.
- With a firm grip, lift front edge of the table approximately six inches and push table leg lock to side. Swing the table leg up and lock into a horizontal position.
- Continue lifting table until table stays are clear of retainers, then pull outward and lower table down.
- Use both seat cushions and one back cushion for a mattress, and leave one back cushion in a vertical position.

**BOOTH DINETTE**

**WARNING** Do not occupy the booth dinette or dining chairs while vehicle is in motion. They are not equipped with occupant restraint systems.

## STORAGE & ENGINE ACCESS



Bed Storage/Engine access area.

To use the storage compartment located under the bed, locate and unlock the bed deck latches. Lift up bed by front edge of mattress platform. Gas struts hold mattress and platform open. To access engine compartment, press down on button in each latch, open engine hatch and secure latch with hook provided.



**NOTE: Do not over stress gas struts by rapidly opening or closing bed access cover. This action can damage the struts or mounts. In extreme cold, gas struts may not hold mattress platform in the open position.**

## AWNING - FRONT DOOR (OPTIONAL)

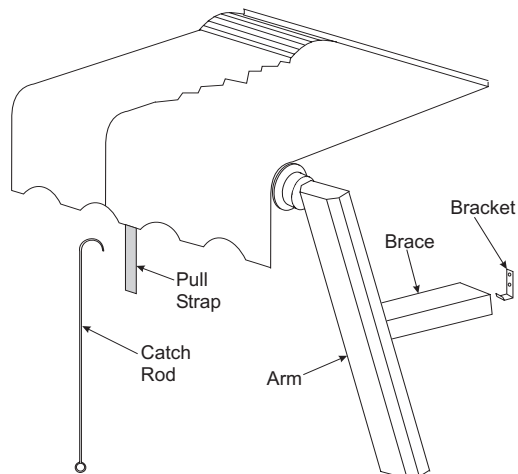

### To Extend The Awning

- Hook the pull strap loop with awning pull rod.
- Pull strap until awning is at full extension. With free hand, lever out inner arms.
- Mate the slot of inner arm with hook on side of motorhome. Repeat procedure for other arm.
- Release strap slowly ensuring inner arms are secure. Slide the strap to rear of awning roll tube and tie to rear arm.
- Loosen locking knobs for both arms and extend arms so the canvas will clear door in the open position.

### To Retract Awning

- Loosen locking knobs for both arms, lower arms to stop bolts. Then tighten knobs.
- Untie the pull strap and slide strap to center of awning roll tube.
- With a firm grip, pull down on pull strap until tension is off the inner arms. Fold inner arms and attach them to the velcro.
- Carefully allow material to wind onto awning roll tube while holding strap in a neutral position. This will allow material to roll up evenly.
- Awning end caps should be against the rubber bumpers. If one end cap is off, pull down on awning pull strap while holding strap slightly to opposite side, allowing awning to roll back up into position.



**CAUTION:** With awning at full extension, do not allow awning to snap back into the retracted position. Personal injury or damage to awning or motorhome may occur.

### Care and Maintenance

Mildew will not form on the awning material itself, but it may form on the dust accumulated on the canopy. A quality vinyl cleaner, such as Carefree Awning Magic, will help keep your awning looking new. Be sure to follow the instructions on the container.



**NOTE:** Allow the awning material to thoroughly dry before rolling the awning up. Metal surfaces should be cleaned with soapy water and thoroughly rinsed.

The motorhome is equipped with a sideout awning that will automatically roll out with the slide room when it is extended. When the slide room is extended, the awning can then be rolled out completely as a window awning. The sideout awning has two devices to help prevent the awning from “billowing” while traveling. The first device is a pair of anti-billow studs, which are located above each end of the awning roller tube. If the awning catches wind and begins to billow, the awning metal wrap will contact the anti-billow stud levering downward and engaging with a plastic gear preventing further unraveling of the awning material. The second device uses two metal wind deflectors which are positioned just below the awning. This helps prevent side winds from scooping under the awning and unwinding the awning material.

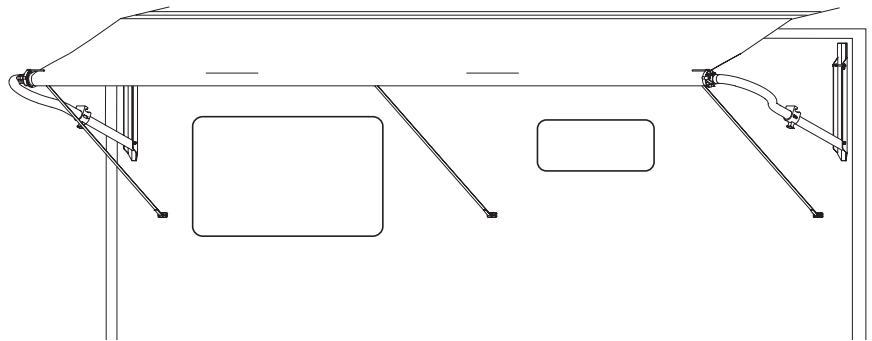

*Awning at full extension.*

### AWNING - SIDEOUT



**CAUTION:** The slide room and sideout awning should be retracted during heavy winds or rain. Rain can be driven under the sideout awning and forced into the motorhome. The sideout awning should be retracted in high wind conditions as damage may occur to the awning or motorhome.



**NOTE:** At least five feet of clearance is needed between the side of the motorhome and any objects, such as trees or fences, to allow the slide room and sideout awning to be fully extended.

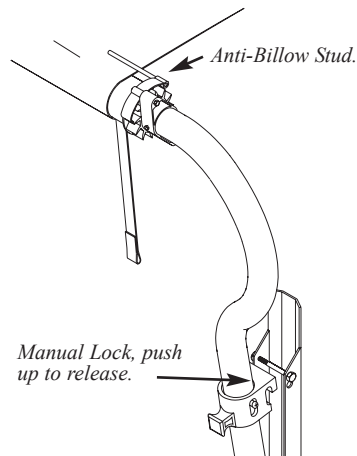

Awning Arm.

### To Extend The Awning

Follow the instructions for extending the slide room. With awning pull rod, unlock travel latches located on the awning side arms. Find the center awning pull strap located between the two metal wind deflectors. Use the awning pull rod to hook the center pull strap loop. With a firm grip, use the rod to pull down on the strap until the strap is within reach. Carefully, grasp the pull strap and secure pull strap loop to the hook located on the side of the motorhome. Secure the straps located at each end of the awning to the hooks provided on the motorhome.

### To Retract The Awning

Remove any leaves or debris that may be present by carefully tapping awning canvas with round end of awning pull rod. Remove awning end straps from the hooks. With awning pull rod in one hand, use the opposite hand (with a firm grip) to remove the center pull strap from the hook. Pull down on strap and engage end of rod with loop in pull strap and carefully, let the spring tension wind the awning up. Do not allow the awning to snap back into position as this may damage the awning or the motorhome. Awning material should roll up evenly with the center pull strap located between the two metal wind deflectors. Latch awning side arm travel locks with the awning pull rod.

## AWNING - PATIO

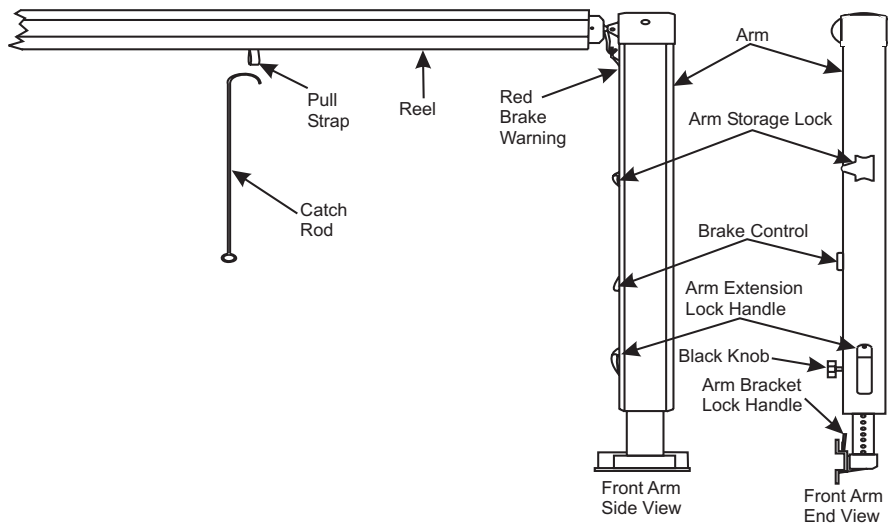

### To Unlock The Awning

1. Loosen the black locking knobs.
2. Lift the arm storage locks located on each upper arm to the unlock position. Slide the brake control, located on the front arm only, to the full up (unlock) position.

### To Extend The Patio Awning

1. Hook the loop of the center pull strap with the pull wand, and draw the awning away from the motorhome to the desired extension. Slide the center pull strap to one end of the awning and store it.
2. Slide the inner rafters to the top of each arm and push outward to the tension canopy. Tighten the black locking knobs.
3. Raise the arm extension lock handles, and slide the awning upward. Lower the lock handles and move the awning arm upward or downward to lock the detent into the hole. First, raise the lock handles on the main side. Next, raise the lock handles to the entry door. Go to the other awning arm and do the same. Make sure the awning is straight.

### To Retract The Patio Awning

Retract the arms and lower the awning until the arms rest on the lower stop bolts and lock into position. Loosen the two black locking knobs. Release the locking tab on the end of the awning leg. Slide the pull strap to the center of the awning while holding on to the strap. Allow the awning to roll up to the stored position.

- Snap the arm storage locks into the down position and tighten the black locking knobs.
- Verify that the brake control is in the locked or closed position.

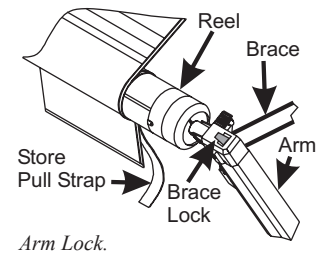

### Rain Release Setting

After the awning has been extended, choose to position it in the rain release position. This position will prevent water build up on the awning. To position the awning, lower one arm of the awning and leave the other arm in the normal position. This will create enough of a slope for adequate water run off.

Rain Release Setting

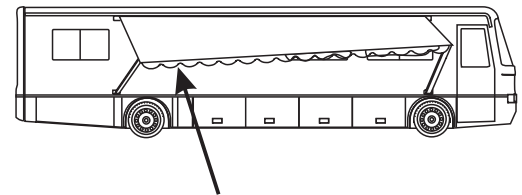

One Arm Lower Than the Other Arm

### Using The Carport Feature

To safely use the carport feature:

1. Extend the braces and lock them into the end of the side arms. Tighten the black knobs.
2. Extend the awning as described under “To Extend Awning.”
3. Unlatch the bottom of the rear arm by pushing in on the lock handle on the arm bracket. Swing the arm away from the motorhome to an upright position.
4. Raise the rear arm extension lock handle all the way up to the unlocked position. Extend the arm to position the awning at the desired height and lower the lock handle to lock the arms in place.
5. Drive the stakes through the bottom holes in the arm.
6. Repeat instructions 1 through 5 for the front arm extension lock handle.

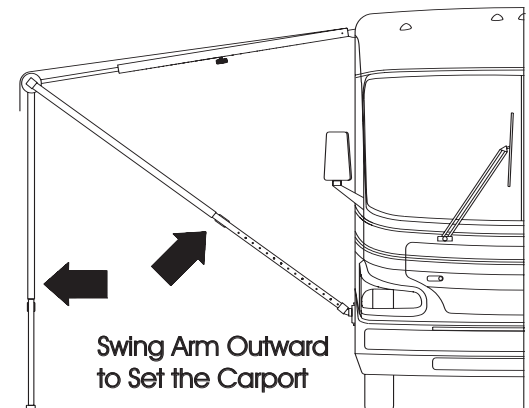

To move the awning out of the carport position, reverse the above steps.

### Securing The Awning For Travel

Before traveling, check the following:

1. The awning is fully retracted against the sides of the motorhome.
2. The black locking knobs are tightened.
3. The storage locks are down and in the locked position.
4. The brake control is in the full down (locked) position, and no red warning is showing.
5. The bottom of the front and rear arms are latched properly into the bottom brackets.
6. The catch rod is stored away.



### **Washing**

On a monthly basis, loosen hardened dirt and remove dust from the awning with a dry, medium bristle brush. Thoroughly rinse both the top and bottom with a hose. Wash both sides of the awning with a quality vinyl cleaner solution using an awning brush. This process can be made easier with our support, plus other awning maintenance products. Saturate the fabric with the solution and leave it on for 15-20 minutes. If necessary, reapply the solution to keep the fabric saturated. Rinse the awning thoroughly. Repeat, if necessary, until most of the stains disappear.

### **Water Leaks**

If leaking occurs after washing, it usually is a result from insufficient rinsing. If water drips through the needle holes in the stitching, use a commercial seam sealer which is available in canvas and trailer supply stores.

Paraffin wax may also be applied to the top of the seams. As the awning “weathers,” these holes will normally seal themselves.

It is normal for slight leakage to occur through the fabric where water is allowed to accumulate or pocket on the fabric. See “Storm Precautions” for information on the awning settings for proper water drainage. Sometimes soap or chemical residue, such as from active agents in insect fog or sprays, can “wet” the fabric so that it appears unable to repel water. Rinse the fabric thoroughly and test to see if it is water repellent after it dries. If leakage continues, after repeating the washing and thorough rinsing, please contact Carefree Awning Magic concerning further maintenance.

### **Storm Precautions**

The warranty does not cover damage caused by acts of God; therefore, steps should be taken to prevent damage from occurring due to wind, rain or storms. If you are leaving or retiring for the night, close the awning. This takes only a few seconds (less time than closing a window), and it gives the best protection for the awning. If unable to close the awning, lower both ends of it as far as you can. This will create a sufficient slope for water run-off. One end may be lowered to sufficiently divert the water, if the awning is monitored.

Water weighs 8.33 pounds per gallon. The awning was not made to withstand the 500 to 700 pounds that could accumulate. It is best not to subject the awning and the motorhome to the needless strain.

---

## **ENTRY DOOR**

The entry door to the motorhome is adjusted at the factory and tested for all operations. The door incorporates three separate seals to eliminate wind noise during travel. This door also uses two separate locks for safety and security. One locking system is for the door handle and the other is a dead bolt locking system. The latching system used is the double action catching to ensure secure and safe latching. There are some adjustments which can be made to help maintain the entry door performance.



**CAUTION** when operating the entry door, ensure the dead bolt latch is fully in the unlock position prior to closing the entry door. Failure to do so can result in damage to the dead bolt and/or entry door.

#### **Adjusting the Entry Door Latch:**

- Determine which bolt needs adjustment.
- Using a 5/8 inch box wrench or socket, loosen the movable bolt. Make all adjustments in small increments. Tighten the bolt firmly after making adjustments. The bolts should have slight up and down movement for vibration control in travel.
- Slowly close the entry door observing the latch and bolt alignment. Do not attempt to latch if the alignment is off. If the alignment is correct, allow the latch to catch in the first position only.
- With just a slight pressure applied to the entry door, the latch should move to the second position. Press on the entry door to see if there is any further movement of the door.
- The entry handle should operate with little effort to open the entry door. An excessive amount of pressure indicates the bolts are set too far back.
- Test the operation of the dead bolt lock to ensure proper functions.

#### **Changing the Glass in the Screen Door:**

- Since the glass slider is plexi-glass, the glass can be bowed for removal and replacement.
- The knob should be removed prior to bowing the plexi-glass.
- Replace with new plexi-glass and reverse the procedure.

#### **Adjusting the Screen Door For Up and Down Location:**

- Loosen the chrome bolts on the hinge side of the screen door: 4 on the top and 4 on the bottom.
- There are slots in the steel hinge to allow up and down movement.
- There are 4 allen type screws on the top hinge and 4 on the bottom hinge to adjust the screen door so it fits properly to the door. We want the hinge to fit tightly to the trim of the door when the screen door is latched to the door and the door is open.
- Check to see that the pad on the inside of the door is not sitting on top of the aluminum trim of the door. If it is, it will hold the screen door away from the door and you will not have a proper seal. If the pad is too large, re-size the pad.

**NOTES**

---

**CHAPTER 4**  
**WATER & LP GAS SYSTEMS**



## WATER SYSTEM

There are two different water systems in your diesel pusher motorhome, fresh water and waste water. The fresh water system contains the water tank, on demand water pump, water heater, water filter (if so equipped) the city water connection. The waste water system consists of: a waste holding tank (gray water), a sewage holding tank (black water), a toilet and drains.

1. Check to make sure the fresh water tank drain valve, located on road-side in the service center is in the closed position.
2. Connect hose labeled for potable water to water source. The water hose from the source to the motorhome sometimes will not have a pressure regulator inline. On a very hot day the hose may expand and burst with the water pressure left in the water hose.
3. Remove white plug in the end of the pressure regulator.
4. Connect water hose to the City water inlet.
5. Knife valve should be in the position shown in the picture.
6. Turn on water at water source.
7. You should be able to listen for the rushing of water going into the fresh water tank.
8. You will need to locate the monitor panel above the entry door or bathroom. Lift the cabinet door and locate the switch marked **test**. This switch is a momentary switch so it will require you to hold down on the switch while testing the level in the fresh water tank. Read the scale as the fresh water tank is filling. When the 2/3 tank light illuminates it should not take much longer to finish filling the tank. Do not leave coach unattended while filling fresh water tank. The light marked F should start to blink, warning you the fresh water tank is almost full. Go back outside to the service center. When the fresh water tank is full, water will come out an overflow tube under the coach on the driver's side.
9. Turn off water supply as quick as possible.

### WATER TANK - FRESH WATER FILL



Water Inlet handle in this position.

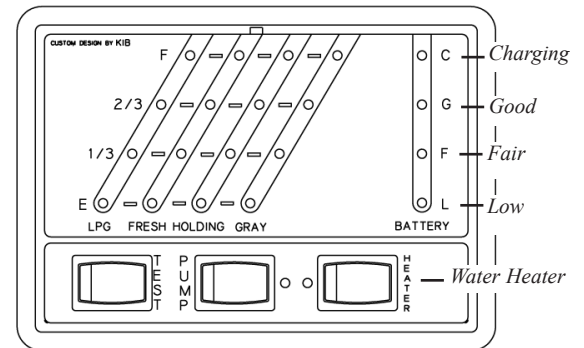

Monitor Panel KIB.

### WATER TANK (Fresh) - GRAVITY FILL

1. Locate the fresh water gravity tank fill, located top left.
2. Unscrew the cap, taking care to keep it clean.
3. Connect water hose marked potable water to water source.
4. Water hose can stick down inside the gravity fill tube.
5. Turn on water source. Listen to the water rushing inside the fresh water tank.
6. Fresh water tank is full when water starts coming out of overflow under the coach.



1. Gravity Tank Fill.  
2. Vent.

## WATER PUMP



Water Pump.

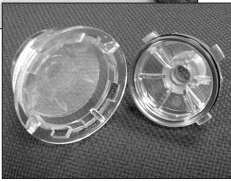

Water Pump Screen.

A water pump is used to pressurize the fresh water system when it is not connected to city water. The water pump is totally automatic and self-priming; operating on demand when water is used. The pump is located in an outside compartment.

Turn the pump on by pushing the switch on the monitor panel. Wait for the water lines and the hot water tank to fill. Close each faucet when it delivers a steady stream of water (cold water first). The pump is now ready for automatic operation. It will start when a faucet is opened and stop when the faucet is closed. Do not allow the pump to run when the fresh water supply tank is empty. Continued operation with a dry tank may open a circuit and/or damage the pump.

The water pump has a clear screen filter attached that will need to be checked every three months to clear large debris.

## Trouble Shooting

Vibration induced by road conditions can cause the plumbing or pump hardware to loosen. Check for system components that are loose. Many symptoms can be resolved by simply tightening the hardware. Check the following items along with other particulars of your system:

### **When the water pump will not start / blows the circuit:**

- Check the electrical connections, fuse or breaker, main switch, and ground connection.
- Is the motor hot? The thermal breaker may have triggered; it will reset when cool.
- Is the voltage present at the switch? Bypass the pressure switch. Does the pump operate?
- Check the charging System for correct voltage and good ground.
- Check for an open or grounded circuit, or motor.
- Check for seized or locked diaphragm assembly (water frozen)?

### **When the water pump will not prime / sputters: (No discharge / Motor runs)**

- Is the strainer clogged with debris?
- Is there water in the tank, or has air collected in the hot water heater?
- Is the inlet tubing / plumbing sucking in air at plumbing connections (vacuum leak)?
- Check for proper voltage with the pump operating.
- Look for debris in the pump inlet / outlet valves or dry / swollen valves.
- Check the pump housing for cracks or loose drive assembly screws.

**The water pump will not shut-off / runs when the faucet is closed:**

- The fresh water tank fill valve is completely closed.
- Check output side (pressure) plumbing for leaks, and inspect for a leaky toilet or valves.
- Look for loose drive assembly or pump head screws.
- Are the valves or the internal check valve held open by debris or is the rubber swollen?

**The water pump is noisy or rough in operation:**

- Check for plumbing which may have vibrated loose.
- Does the mounting surface multiply noise (flexible)?
- Check for mounting feet that are loose or compressed too tight.
- Look for loose pump head to motor screws (3 long screws).
- Is the motor with the pump head removed. Is noise coming from the motor or pump head?

**The water pump is rapid cycling:**

- Look for restrictive plumbing/flow restrictors in the faucet's or shower heads.



**WARNING: Before leaving your coach for extended periods of time(i.e. overnight or longer), be sure that the city water and all water pumps have been turned off. Damage from neglect will be the responsibility of the owner and not Monaco Coach Corporation.**

When connecting your motorhome to fresh water, be sure to use a hose manufactured and labeled for potable water to insure that the hose will not flavor the water.

1. Remove white plug in the end of the water inlet.
2. Connect water hose to the city water inlet.
3. Knife valve handle should be in the position shown in the picture.
4. Turn on water at water source.
5. The water pump can either be in the OFF position or in the ON position. It will not affect the water pump to leave it on.
6. The fresh water connection has a built in pressure regulator and a one way check valve that protects the motorhome to 45 lbs.
7. You may need to open each faucet one at a time to rid any trapped air inside the pipes.

**WATER  
- CITY HOOK-UP**



*Water Inlet handle in this position.*



**CAUTION: Some water sources develop high water pressure, particularly in mountainous regions. High water pressure is anything over 55 psi (pounds per square inch). Excessive water pressure may cause leaks in water lines and / or damage the water heater. Your coach does come with a pressure regulator.**



## **WATER SYSTEM - DISINFECTING**

Disinfecting the water system with chlorine bleach (superchlorination) protects you and your family from bacteriological or viral contamination from any common water source.

You should disinfect the water system if your motorhome is new or hasn't been used in a long time. Every three months use the following procedure to disinfect water system:

- Prepare a chlorine solution using one gallon of water and 1/4 cup of chlorine bleach (sodium hypochlorite solution). Use one gallon of solution for every 15 gallons of tank capacity.

Example: Add two 2/3 gallons of solution to a 40 gallon tank. Add four 2/3 gallons solution to a 70 gallon tank. This mixture puts a 50 ppm (parts per million) residual chlorine concentration in motorhome water system. This concentration will act as a quick-kill dosage for harmful bacteria, viruses and slime-forming organisms. Concentrations higher than 50 ppm may damage water lines and/or tanks.

- Fill the tank with fresh water. Open each faucet in turn and run the water until you smell a distinct chlorine odor. Do not forget the hot water taps and shower faucets. Allow the system to stand for four hours when disinfecting with a 50ppm solution.
- Drain the system and flush with fresh water. Flush with fresh water repeatedly, if necessary, until no chlorine taste or smell is left in the water system.



**NOTE: To perform this task, you will need to remove the cap off the gravity water fill. Add solution into the fresh water tank. When finished, secure gravity feed cap.**

---

## **WINTERIZING with AIR PRESSURE**

To use air pressure to winterize your motorhome water system you will need to have access to an air compressor and an adapter to connect the air line to your water system. Adapters can be found at RV supply stores. You should not exceed 40 pounds p.s.i. when hooked to water lines. Higher air pressures could damage lines.

1. Drain fresh water tank by opening drain valve located in the water service center on the roadside.
2. Open both low point drain valves.
3. Remove water heater drain plug and open the pressure relief valve.
4. Let all water drain. Turn on water pump and allow it to run for 30 seconds so that all the water is cleared out of the water pump. The pump switch is located on the monitor panel located above the entry door. Open cabinet to access monitor panel.
5. After you have drained water from the fresh water tank,

- hook an air hose to the city water connection located on the control panel in the outside compartment. Blow out the water lines until no more water can be seen coming out of the drain lines. Do not exceed 40 p.s.i. in the water lines.
6. Close the water heater heater bypass valves located inside the motorhome next to the water heater.
  7. Replace water heater drain plug and close the pressure relief valve. Open all faucet's one at a time, while the air is on, to clear the water from each faucet supply line.
  8. While the air is still on, hold the toilet flush pedals down until the water has stopped running.
  9. Unhook the air hose and close the city water connection.
  10. You will need one gallon of RV antifreeze to protect various water lines in your motorhome. Pour one pint in both the kitchen and bath shower drains, two pints go in the bath sink drain with some antifreeze going into the gray tank to protect the drain valve. While holding down the toilet flush pedal, pour another three 1/2 pints into the toilet letting the antifreeze run into the black tank to protect the valve there. Pour the last 1/2 pint of antifreeze into the toilet after you have released the flush pedal. Use a soft cloth to wipe out the sinks and shower, after you pour in the antifreeze, to protect the surfaces from stains.
  11. Leave the low-point drains open until you are ready to use your motorhome again.



**WARNING: When draining the low water drain lines and water heater, be sure water is not hot. Hot water from the lines can burn you.**

Your motorhome was not designed for extended use in below freezing (32° F/0° C) weather. However, you may not experience any problems as long as the temperature doesn't fall too low. Interior water lines, fixtures, water storage tanks and pumps are normally protected from moderate freezing temperatures as long as the furnace operates. Exposed drains may freeze quickly. If you are in doubt about what temperatures your motorhome will tolerate, winterize with a potable antifreeze.

The diesel engine will operate in extremely cold environments if the engine is properly prepared and maintained. The correct lubricants, fuels, and coolant **must** be used for the cold weather range for which the motorhome is being operated in.



**NOTE: It is not recommended to extend the slide room in snow, sleet, ice or freezing rain. There may be extensive damage resulting from awning freeze up.**

**COLD  
WEATHER USE**

## **WINTERIZING Using Nontoxic Antifreeze**

1. Drain the fresh water tank, water heater tank, holding tanks and fresh water lines by opening the low point drain valves located near the water heater.
2. With the water pump ON, open all faucets and hold down the toilet flush pedal for 20 seconds.
3. Close all drain valves and faucets.
4. Close the water heater bypass valves, located near the water heater. You do not want any antifreeze going into the water heater.
5. Pump 10 gallons of **nontoxic**(potable) winterizing antifreeze into the fresh water tank. This is done by disconnecting the line from the fresh water tank pump and reconnecting a line from a container of winterizing solution to the line coming from the tank.
6. Turn on the water pump and, starting with the fresh water faucet farthest from the water tank, open both hot and cold faucets (one at a time), until the antifreeze flows through. Let enough antifreeze drain so the water in each “P” trap is replaced with antifreeze.
7. Repeat this procedure at each faucet and toilet.
8. Reconnect the line from the fresh water tank to the pump.
9. If the motorhome is equipped with an ice maker, remove the 3/4 inch fitting and flush antifreeze through the water line.
10. Wipe sinks with cloth to prevent staining.



**WARNING: You should use only non-toxic RV antifreeze that is specifically made for potable water systems. Automotive antifreeze, if ingested, can cause blindness, deafness or death.**



**WARNING: It is recommended that this procedure be done by a qualified RV service technician familiar with motorhomes, such as your authorized selling dealer.**

Water system problems and leaks usually fall into two categories: system problems and problems caused by improper use or lack of attention. These problems usually stem from improper winterization, poor maintenance, road vibration and campsite water pressure variations. Check all plumbing connections for leaks at least once a year. If the water pump runs when a faucet is not open, check for a water leak; be sure the tank drain valves are closed.

In tracking water lines the cold water lines are blue and the hot water lines are red. When using air pressure to help in troubleshooting, never exceed 40 psi of air pressure into the system.

Once a month you should check the screens on the water faucet's in the galley and bathroom. Remove and clean as necessary. The water pump has a clear filter attached that will need to be checked every three months to clear large debris.

While working on the shower faucet, there is an access panel located in the bedroom closet. Remove the four screws and remove wood panel. This will give you access to the back of the shower faucet.

The water system uses a water check valve, located in the service center. The water check valve prevents water coming out the inlet water connection when the coach is only running on the water pump. If, for some reason, water is coming out the inlet you can connect a water hose to the inlet and turn on the water supply to unstick the check valve.

Use water hose that is marked for potable water only. Care in your water hose is a must. After each use drain the water hose and coil the hose neatly attaching the ends together. This will keep any debris and insects out of the water hose.

## WATER SYSTEM - TROUBLESHOOTING



*Water Check Valve.*



*Fresh Water Hose.*

The waste drainage system was designed to provide adequate and safe storage and/or discharge of waste materials. All materials used in fabrication and installation of the system are tested by a nationally recognized testing laboratory. The entire fabricated waste system is factory tested in accordance with the American National Standards Code A119.2. The drainage system uses ABS plastic piping and fittings connected to the sinks, shower, toilet and holding tanks. It provides for their drainage to an outside termination. The motorhome should be reasonably level for the best operation of the system. There are two separate systems: one for waste water (gray water) and one for sewage waste (black water). Each one has its own control valve and empty through sewer drain hose. When traveling, we recommend the holding tanks be empty or less than half full.

## WASTE WATER SYSTEMS

## **Draining the Holding Tanks**

The holding tank drain valve handles and the drain termination is located on the roadside of the motorhome.

The sewer hose should be stored in the service center area. Drain the SEWAGE (black) tanks first and then the WASTE (gray) tank. By using this sequence the sewage will be flushed out of the drain system and sewer hose by the waste water.

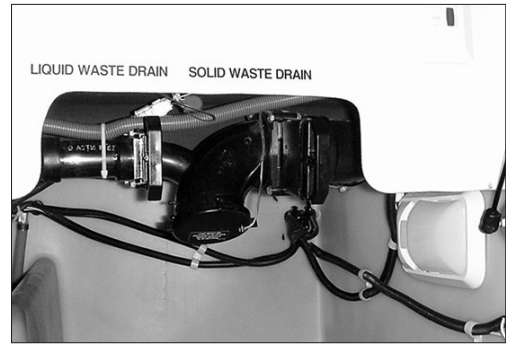

*Draining the Holding Tanks.*

---

## **Waste Holding Tank Grey Water**

The waste water tank is located under the floor in the bay of the motorhome. The waste tank stores the sink, shower and clothes washer drain water. A chemical is not required in this holding tank.

---

## **Sewage Holding Tank Black Water**

The sewage holding tank is located directly beneath the toilet. Before using the toilet you need to treat the holding tank with water that is mixed with an odor controlling chemical. The chemical is readily available at any RV supply store. Be careful not to spill the chemical on your hands, clothing, or the carpet; the chemical can cause a permanent stain. To treat the tank, flush the toilet to allow the chemical to mix with the water. Continue to flush the toilet until there is at least 1 inch of water/chemical solution in the tank directly under the toilet.

---

## **To Drain:**

1. Remove the sewer hose from the storage location.
2. Check that all drain valves are in the closed position.
3. Remove the safety cap from drain termination.
4. Connect the sewer hose to the drain termination by attaching the hose coupling to the drain termination and turning it 90 degrees, allowing the tabs on the hose coupling to lock onto the tabs on the sewer termination.
5. Place the discharge end of the sewer hose into the sewer connection. Check that all the connections are secure to prevent accidental spillage.
6. Open the larger black water drain valve first by pulling the handle out until it stops. After the tank has been drained, open the smaller waste water drain valve. This will help flush solid waste through the drain hose. After the tanks have been flushed out, close both valves by PUSHING the handles back in.
7. Flush the sewage tank. Connect the water supply hose to the SEWAGE TANK FLUSH connection on the water connection panel. Turn the water on and flush the system for approximately two minutes or until the water runs clear from the drain hose. Open black tank drain valve and leave open while flushing. Turn

- the water off. Disconnect the hose when finished flushing the system. Never leave the coach unattended when using the black tank flush.
8. After using the black tank flush, close the black tank valve.
  9. Disconnect and rinse out the sewer hose and replace the termination safety cap.



**NOTE: When using the black tank flush do not leave the motorhome unattended as flooding may occur. Turn the water supply to the black tank flush off when finished.**



**NOTE: Periodically, after the tanks have been emptied, it is recommended to flush out each tank with fresh water to dislodge solids. To clean the holding tanks add a detergent solution to the tanks after draining. The agitating action from driving will clean the tanks.**

Most states and parks have strict regulations about discharging wastes, except into authorized disposal systems. Dumping raw sewage from toilet holding tanks, except at authorized dumping stations, is universally prohibited. Illegal dumping along roadside, by a minority of recreational vehicle users, has resulted in tough laws, and has unfairly labeled all camping vehicle trailers as unwelcome in some areas. Most national, state and private parks have either a central dump facility or a campsite hookup for sewage. You will find a list of dumping stations from coast to coast in Woodall's Campground Directory, Trailer Life's RV Campgrounds and Services Directory, Rand McNally's Campground and Trailer Park Guide, Good Sam Park Director (Good Sam Club), and other RV publications. Some major oil companies offer dump facilities at selected stations. Plan ahead, and you will find few inconveniences in proper and legal disposal of holding tank waste.

### ***Proper Waste Disposal***

- Do not flush facial tissues. They are treated chemically to give them wet strength and they will not dissolve like toilet paper. Special holding tank tissues are available at most RV supply stores. Also, white toilet paper dissolves faster than colored papers.
- Do not use strong detergents or full strength bleach to deodorize and disinfect. Use odor control chemicals made especially for holding tanks.
- Do not put automotive antifreeze, ammonia, alcohol or acetone in holding tanks. Some chemicals will dissolve plastic.
- Do not put large table scraps in tanks. They could get stuck or damage valve seals.

### ***What Not to Put in the Holding Tanks***

Keep the holding tank (black water) valve closed at all times, except when dumping. Waste holding tanks (gray water) can remain open to drain when parked; connect the drain hose to the sewer hookup. Before emptying,

### ***When Connected to Sewer Hookup***

be sure there is enough liquid in the tanks to provide a smooth flow through the valve and drain hose. Sufficient liquid in the tank causes a swirling action that should take with it accumulated solid wastes. Empty the tanks when they are 1/2 to totally full.

---

## TOILET OPERATION

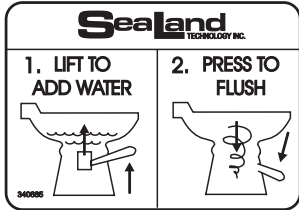

The toilet operates from either the fresh water tank or the city water supply. The water pump must be turned on or city water connected. The toilet flushes directly into the black water holding tank.

1. To add water to the toilet before using, lift the flush lever until the desired water level is reached. Generally more water is required only when flushing solids.
2. To flush the toilet, push the lever all the way down until the sewage leaves the toilet. Water flow pressure varies at different locations, therefore holding the flush lever down for five to eight seconds may be required. We recommend two gpm flow for proper rim and bowl wash.
3. To operate the remote mounted hose sprayer push down the lever and hold it.
4. Release the flush lever by allowing it to snap back which permits positive sealing around the flush ball.
5. A small amount of water should remain in the bowl.



**NOTE: Holding the flush lever down longer than necessary results in excessive water usage.**

---

## Cleaning

The toilet should be cleaned regularly for maximum sanitation and operational efficiency. Clean the toilet bowl with a mild bathroom cleaner. Do not use chlorine or caustic chemicals such as drain opening types, as they will damage seals.

1. Clean out the system by flushing several gallons of fresh water through with one cup of dry laundry detergent.
2. Add odor control deodorant, in the amount specified for your holding tank capacity, after cleaning and every few days during use.

---

## Service Tip

To find leaks check behind or under the toilet. Take four or five sheets of toilet tissue and wipe all seams and waterline connections. Start at the top of the unit and work downward. When the tissue comes in contact with leaking water, it will immediately change texture.

If your motorhome is in storage for six months it is a good idea to spray silicone on the toilet valve and work it back and forth.

---

## Drain Traps

Sinks and shower drains have a water trap to prevent holding tank odor from entering the motorhome. These traps must have water in them to trap odors. During travel water can spill out of sinks and shower drain traps. Also, during storage the water can evaporate and allow odor to enter the motorhome. If odor is detected, run water into the sinks and shower to fill drain traps.

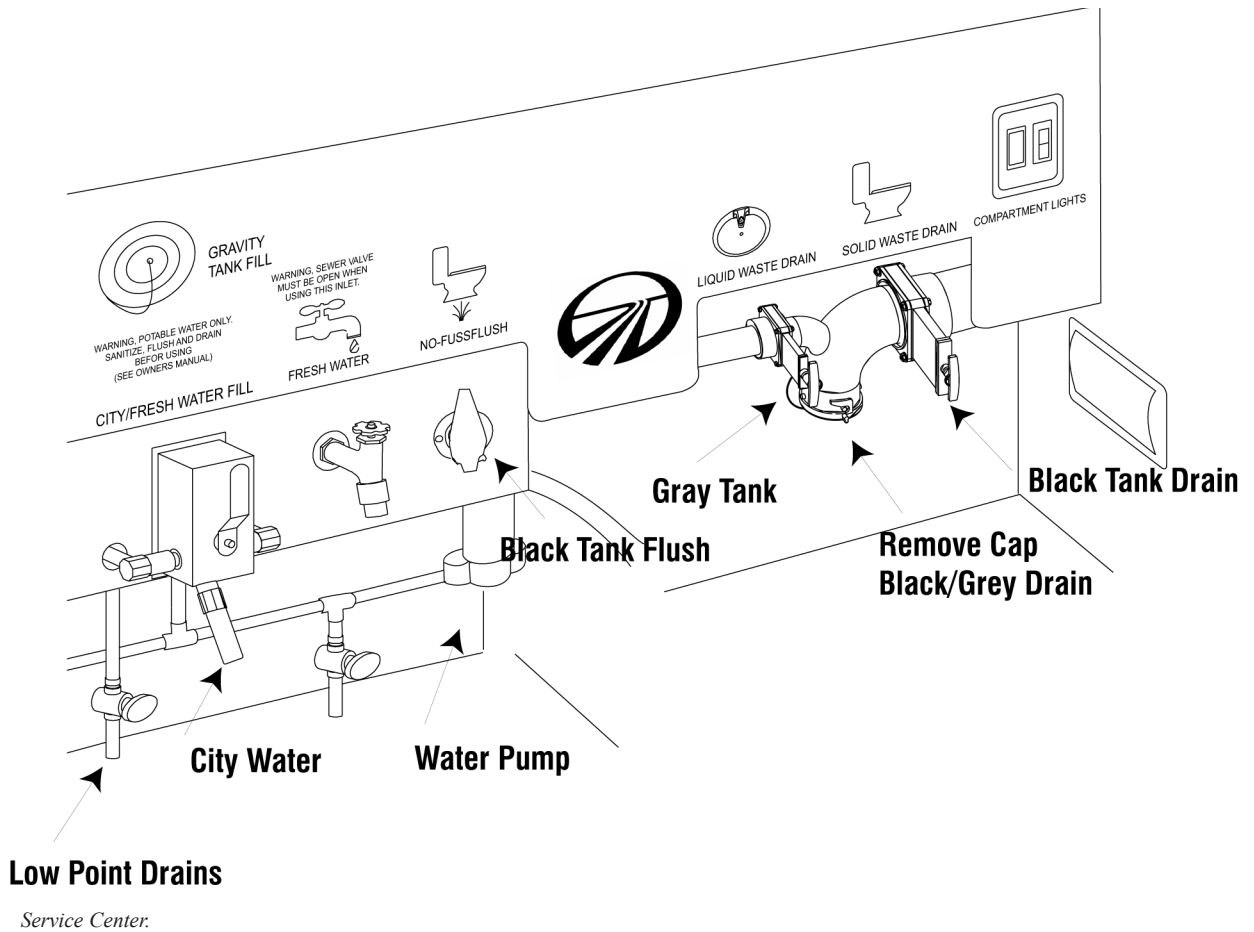

## TANK CAPACITIES

Tank Capacities* 34Y/36Z	
10 gal.	Water Heater
52 gal.	Grey Water
52 gal.	Black Water
80 gal.	Fresh Water
75 gal.	Fuel Tank
38 gal.	LP Tank**

\* All tank capacities are approximate.  
 \*\* Actual filled LP capacity is 80% of listing due to safety shut off required on tank.



## LP GAS SYSTEM

The components for your motorhome's LP gas systems are approved for use in camping vehicles by a nationally recognized testing laboratory. When properly handled, LP gas is a clean-burning dependable fuel for heat producing components. The LP gas tank mounted in your motorhome contains liquid petroleum gas under high pressure. As fuel is used, liquid gas vaporizes and passes through the tank valve to a regulator that automatically reduces the pressure. Low-pressure gas is then distributed to the components through a pipe manifold system. Component lighting problems are commonly caused by an improperly adjusted gas regulator. Never attempt to reset the regulator yourself. Have your dealer or an authorized service person make adjustments. In high altitude or extreme cold weather you may experience a shortage of LP gas. You can adjust to this by not running more than one component at a time, such as turning off the furnace while using the range. If you are going to be in higher altitude or cold climates for a long period of time, an authorized service person can adjust your LP regulator for these conditions.

We recommend that you have the LP gas system checked by an authorized dealer at least once a year, and after every extended trip. Although the manufacturer and dealer both test carefully for leakage, travel vibrations could loosen fittings. Leaks can be easily found by applying leak detector solution at the connections. If leak detector solution is not available, a soapy water solution made with dish soap can be used. Tightening the fittings usually stops any leaks. If not, shut off the main gas valve at the tank and see your authorized dealer for repairs immediately. Hand tighten the tank valves only, do not use a wrench or pliers. Over tightening may damage the valve seats and cause them to leak. If you have a leak identifying odor, and suspect leaking gas (it smells like rotten eggs, sulfur), never light a match or have an open flame.



**WARNING: A fire or explosion from ignited gas or gas fumes can seriously injure you or cause death.**

Shut off all appliances and LP gas tank valves (located on side of LP gas tank underneath the motorhome) when the motorhome is in storage. Turn off all pilot lights and appliances. Disable igniters (see operating instructions in Chapter 3) during the refueling of the motorhome and filling the LP gas tank to prevent a fire or explosion.

If you smell gas (a rotten egg or sulfur smell) at any time, perform the following steps immediately:

- Manually turn off the main gas supply.
- Do not touch any electric switch.
- Extinguish any open flames.
- Open windows and doors.
- Do not try to light any appliance.
- Exit the motorhome and contact the service center of a gas supplier.

If you are storing LP gas tanks (do not transport or store LP gas tanks, gasoline, or other flammable liquids inside the motorhome) that are not connected to an LP gas system. Install an approved plug in the tank outlet holes to prevent leaks. Do not

store empty LP gas tanks. Keep open flame and spark producing materials away from the LP gas area. If this warning is ignored, a fire or explosion could result.

Each gallon of LP gas produces approximately 92,000 BTU's of heat. One 27 gallon tank produces 2 million BTU's. Total consumption depends on the rate of usage by each appliance and the operating time. The oven and heating systems use the most gas. With sub-freezing temperatures and high winds, consumption by the furnace can be very high. Check the tank level often in cold weather.

A primary manifold black steel pipe running throughout the motorhome distributes LP gas to secondary lines. All secondary lines leading to gas appliances are made of copper tubing with flared fittings. If any lines rupture, do not attempt to splice them. Always run a new line. We recommend gas distribution work be performed by an authorized dealer or an authorized service technician. When removing or servicing any gas appliance, manually close the main valve located on the side of the LP gas tank. This will prevent dangerous gas leakage that could result in an explosion and possible serious injury. If you suspect a gas leak, get the system inspected and repaired by a qualified service technician as soon as possible.

Woodall's Campground and Trailer Guide and other publications list refueling stations. Many travel parks sell LP gas. Shut off the pilot lights, appliances and igniters before filling the LP gas tank, to prevent a fire or explosion. Have a trained service person fill the LP gas tank. The LP tank fill and bleed valves are located in the LP tank access outside compartment. Caution the service technician, if your tank is new and being filled for the first time, to purge any air from the tank before filling.

When the tank is filled to the proper level there is space available for the conversion of liquid into gas. If a tank is over filled it may vent pressure. When this happens you may detect a strong rotten egg odor near the tank and/or hear a hissing noise.



**WARNING: Do not attempt to adjust the regulator, it is preset at the factory. If adjustments need to be made it requires special equipment. Failure to follow these instructions may result in a fire or explosion and cause severe personal injury or death.**

## LP GAS Consumption

## LP GAS Distribution Lines

## LP GAS TANK

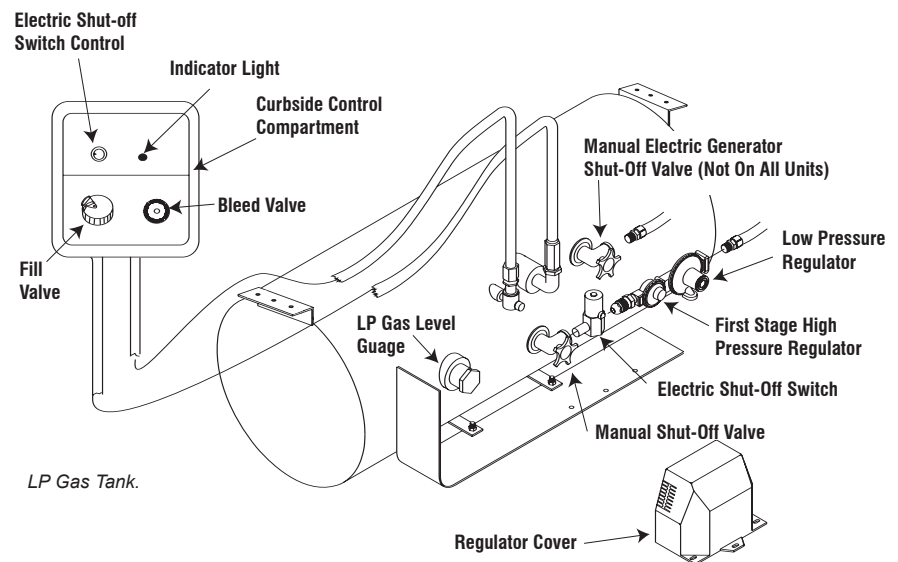

## LP GAS Regulator

The regulator is the heart of an LP gas system. The LP gas in the tank is under high pressure. The regulator reduces the pressure of gas so that it is safe to use with various appliances. The regulator is equipped with a vent so that it can breathe. This means that if pressure in the LP tank is too high the regulator will allow gas to escape through the vent until pressure returns to a normal range. It is important to keep the vent clean and clear of obstructions or corrosion. If the vent becomes clogged, pressure from LP tank could cause a failure of the components. If you notice any corrosion, contact a qualified LP gas service technician. The regulator is mounted so that the vent faces downward. If the vent becomes clogged you can clean it with a toothbrush.



**WARNING: When the alarm sounds, open all doors and windows to air out the motorhome and turn gas off at LP tank. Do not reenter motorhome until the alarm stops sounding. If the alarm sounds a second time after gas is turned back on, leave gas off and contact a qualified service technician to find the source and repair the gas leak.**

## LP GAS VALVES Operating Instructions

- Manually open the main shutoff valve located on the side of the LP tank.
- The level in the LP gas tank can be checked by pushing the button on the monitor panel.
- Turn off the manual valve on the LP tank when the motorhome is between trips.
- Hand tighten the manual valve. Do not use a wrench or pliers to close the valve.
- The manual valve is designed to be closed by hand, over tightening may permanently damage the valve seat.

## LP GAS DETECTOR



LP Detector.

LP Gas is heavier than air and will settle to the lowest point, which is generally the floor of your motorhome. The LP detector is also sensitive to other fumes such as hair spray, most of which contain butane as the propellant. Butane, like propane, is heavier than air and will settle to the floor level where it will be detected. When this occurs, press the reset button to stop the alert sound for 60 seconds.

The other combustibles which will be detected include alcohol, liquor, deodorants, colognes, perfumes, wine, adhesives, lacquer, kerosene, gasoline, glues, most all cleaning agents and aerosol can propellants. Most are lighter than air in their vapor state and will only be detected when the motorhome is closed up.



**CAUTION: This detector cannot alarm during the 3-minute warm-up cycle.**

When the power is first applied the Yellow LED will flash for 3 minutes, while the detector is stabilizing. At the end of that time the LED will turn Green indicating full operation. If the detector has detected unsafe levels of gas it will immediately go into alarm.

---

Simply press the Test switch any time during the warm up cycle or while in normal operation. The LED should flash RED and the alarm should sound. Release the switch. This is the only way you should test your detector. The test feature checks the full operation of the detector.

***Test***

---

The Red LED will flash and the alarm will sound whenever a dangerous level of propane or methane gas is detected. The detector will continue to alarm until the gas clears or the Mute switch is pressed.

***Alarm***

- 
1. Turn off all gas appliances (stove, heater, furnace), extinguish all flames and smoking material. Open doors and windows. Evacuate.
  2. Turn off the propane tank valve.
  3. Determine and repair the source of the leak. Seek professional help if necessary.

***Procedures  
to Take  
During an Alarm***



**CAUTION: Do not reenter the motorhome until the problem is corrected.**

---

Press the Test-Mute button when the detector is in alarm.

***Alarm Mute***

1. The Red LED will continue to flash and the alarm will beep every 30 seconds, until the gas level has dropped to a safe level.
2. The LED will flash Green until the end of the Mute cycle.
3. If dangerous gas levels return before the end of the Mute cycle, the alarm will beep 4 times and return to phase 1.
4. After 2 minutes the detector will return to normal operation (solid Green) or resound the alarm if dangerous levels of gas remain in the area.

- 
1. Vacuum the dust off the detector cover weekly, (more frequently in dusty locations), using the soft brush attachment of your vacuum.
  2. Do not spray cleaning agents or waxes directly onto the front panel. This action may damage the sensor, cause an alarm or cause a detector malfunction.

***Care of  
Your Detector***

**NOTES**

---

**CHAPTER 5**  
**ELECTRICAL SYSTEMS**



**ELECTRICAL  
SYSTEMS  
120/240 AC**

The motorhome 120/240 volt AC system can be operated from three different power sources. Shore power is the most efficient and should be used whenever possible. The on board generator has a limited amount of 120 volts AC output power. This can be used when shore power is unavailable. The inverter/converter supplies silent AC power by the use of the motorhome house batteries. This source has limited AC power output and should be used sparingly.

The motorhome 120 volt AC circuit breaker panel is supplied with power from two different sources. The 50 amp shore power cord or the on board generator. The selection of the power source being used is done automatically by the use of an electrical switching device known as a transfer switch.

The power requirement for the motorhome is 50 AMP 120/240 volt AC single phase.

**Shore Power  
Requirements**

**NOTE:** In many instances 50 amp shore service is not available and care will have to be used when operating the appliances and using the outlets so as not to overload the shore power service being used.



**WARNING:** Before plugging unit into shore power, starting the generator, or using the inverter make sure all the appliances are off.

The generator can be selected for use when AC shore power is not available. The motorhome on board generator has limited 120 volt AC power output capabilities. The generator's maximum amount of output power is specified in watts, which is calculated at an elevation 500 feet above sea level. The figure will decrease with a higher altitude. Temperature also affects total maximum output. Fuel consumption is based upon a percentage of AC electrical load applied to the generator. While using the generator, care will have to be taken when operating appliances and outlets so as not to overload the generator. The "genset" can be fueled from two different sources depending on generator engine type; diesel or liquefied petroleum (LP). If the generator is a diesel, it will use fuel from the main fuel tank; if it is LP, it will use fuel from the LP tank.

**Generator**

The inverter/converter (if applicable) can be used for silent AC power if shore power is not available, and using the generator is not going to be selected as a secondary power source option. This device has limited AC power output, measured in watts. It operates only selected appliances and outlets. The inverter/converter is two components in one. Its first function is as an auxiliary 120 volt AC power source that uses 12 volt DC house battery power to invert to 120 volts AC. The second function of the inverter/converter is to use 120 volts AC power, supplied from either shore power or the generator, and convert it to 12 volts DC power to recharge the batteries.

**Inverter/  
Converter**



## TRANSFER SWITCH

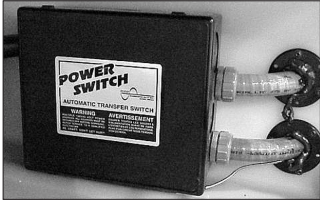

Transfer Switch.

The transfer switch automatically transfers power from the shore cord, through the transfer switch, and to the 110 volt AC breaker panel. When the generator is used, the transfer switch has a time delay built into it. This allows the “genset” time to warm up before an AC load is applied to it. The transfer switch will automatically select the generator over shore power, even though shore power is hooked up.



**NOTE:** To prevent damage to the transfer switch, do not have appliances on or AC loads plugged into outlets when hooking up to shore power or starting generator. The transfer switch will begin to disengage between 85-90 volts AC. Operation at this voltage may damage transfer switch, appliances or other items plugged into outlets.



**WARNING:** Keep fingers away from metal contacts of shore plug end. Avoid standing water. Serious electrical shock and personal injury can occur. To avoid the risk of an electrical shock, turn the circuit breaker off for the shore power outlet before making shore power connection.

## Getting Started

If 50 amp shore power service is available, all that is necessary is to connect the motorhome to the 50 amp shore power service using the supplied shore power cord. The cord is located in the compartment on the driver’s side of the motorhome. After connecting the unit to shore power, wait approximately one minute for the inverter to “stabilize” charging of the batteries before starting air conditioners or other large AC loads. In many instances 50 amp shore service is not available. Proper electrical adapters must be used to connect the supplied shore power cord to the shore service available. When connecting to anything other than 50 amp shore service, use caution not to overload the supplied shore service breaker. Appliances and outlet loads will have to be operated in sequence, rather than all at the same time.



**NOTE:** Below are the three types of shore power outlets most commonly used.



50 AMP Outlet.

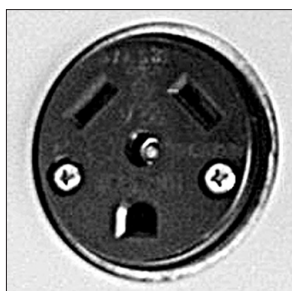

30 AMP Outlet.



20 AMP Outlet.

# GENERATOR 120 AC

The generator is located in the front compartment of the motorhome. The generator can be started from the following locations:

- The generator remote switch located in the center dash panel
- The generator control panel located on the generator.

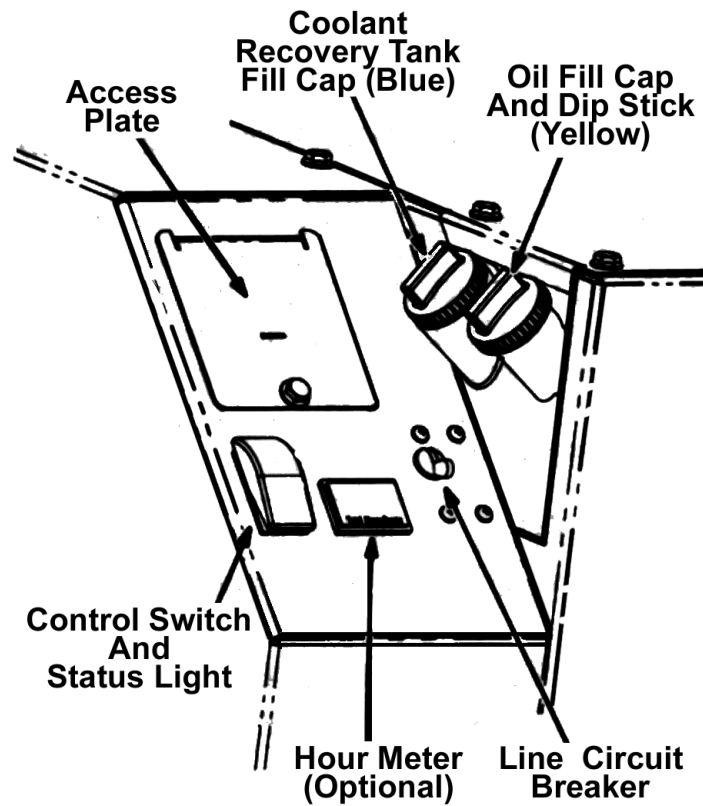

Generator Control Panel Diesel (Optional).

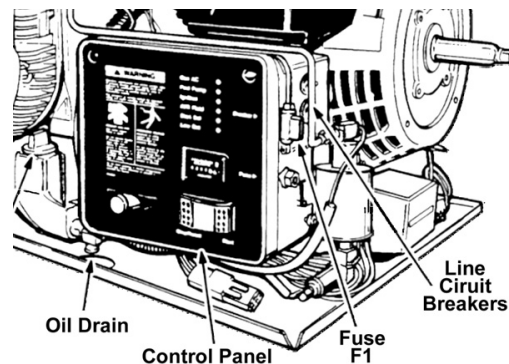

Generator Control Panel LP (Standard).

### **Prestart checks**

Prior to the first start of the day, perform a general inspection including oil and coolant levels. Keep a maintenance log on number of hours in operation since the last service. Perform any service or maintenance that may be due.

- **Make sure people and animals are clear of hazards of electrical shock and moving parts.**
- **Make sure appliances and other large AC electrical loads are off.**

---

### **Starting The Generator**

Push and hold control switch in START position until the generator starts. Release switch. On diesel models the control switch may flash up to 15 seconds, indicating engine preheat.



**NOTE: Diesel models may require priming. Hold control switch in OFF position for one minute. Repeat if necessary. The diesel generator fuel pick-up tube is cut to approximately 1/4 tank so as not to run the main engine out of fuel.**



**WARNING: Excessive cranking can overheat and damage the starter motor. Do not crank for more than 30 seconds at any one time. Wait at least two minutes before resuming. If Genset fails to start, refer to the manufacturer's owner's manual.**



**WARNING: When the motorhome is parked, position the dash air conditioner control in the OFF position to prevent outside air from entering the motorhome. The engine exhaust contains carbon monoxide, which is an odorless and colorless gas. Carbon monoxide is poisonous and can cause unconsciousness and/or death. Inspect the exhaust system thoroughly before starting the generator. Do not block the exhaust pipe or situate the motorhome where the exhaust may accumulate either outside, underneath, or inside the motorhome or any nearby vehicles. Operate the generator only when safe dispersion of exhaust can be assured. Monitor the outside conditions to be sure that the exhaust continues to disperse safely.**

---

### **Stopping The Generator**

Turn off the appliances and disconnect other AC loads being used. Allow the generator to run unloaded for at least one minute before shutdown. This will allow the engine to cool. Push and hold the control switch in the **STOP** position until the generator stops. Release the switch.



**NOTE: Diesel models require only a momentary stop signal.**

The AC output of the genset powers the motorhome air conditioners, the AC inverter/converter charger, all appliances and items plugged into the electrical outlets of the motorhome. The number of electrical appliances that can be operated at any given time depends upon how much power is available from the genset. If the genset is “overloaded” or a short circuit causes “over current”, either the genset will shut down or the circuit breaker will trip. If power consumption, in total, exceeds the genset power output, compensation for temperature and elevation may be necessary to operate some appliances in sequence, rather than all at the same time.



**NOTE: The genset may shut down when it is loaded nearly to full power and an air conditioner (or other large motor load) cycles on. For a brief moment during start up, an electric motor can draw up to three times the rated power. For this reason, it may be necessary to operate some appliances in sequence when air conditioners or other large motor loads are on.**

It is important to remember that air density decreases as altitude increases, causing the genset engine power to decrease. Power decreases at approximately three percent of the rated power each 1,000 feet (305M) of increase in elevation above sea level. It may be necessary to operate fewer appliances at the same time when the camping location is at a higher elevation. (For example: 7,500 watt genset @ 5,000 ft. = 6,375 watts net.) Temperature also affects maximum output watts. (For example: @ 120 degrees a 7,500 watt genset produces 6,000 watts net.)



**REFERENCE: The diesel generator may shut down for other reasons beside “overloads.” A blink code may appear on the control switch. Refer to the manufacturer’s owner’s manual to obtain an explanation of the codes.**

If a circuit breaker trips in the main AC breaker panel, or on the genset control panel, there may be a short circuit or too much load. If a circuit breaker trips, disconnect or turn off as many loads as possible. To reset the circuit breaker, switch the circuit breaker to **OFF**; then switch to **ON** to reconnect the circuit. If the circuit breaker immediately re-trips, the electrical distribution system has a short or the circuit breaker is faulty. Call a qualified electrician. If the circuit breaker does not re-trip, reconnect a combination of loads that will not overload the genset or cause the circuit breaker to trip again. Remember to compensate for elevation and temperature changes when reconnecting loads.



**NOTE: The genset will continue to run after a circuit breaker trips.**



**NOTE: An appliance or load may have a short if it causes the circuit breaker to trip after reconnection. DO NOT continue to reset the breaker. Have the problem corrected before resuming operation.**

### **Genset Exercise**

If use of the genset is infrequent, “exercise” the genset once a month by operating the genset at approximately half the maximum rated output for two hours. This “exercise” will help promote better starting, more reliable operation and a longer engine life. The procedure drives off moisture, relubricates the internal engine parts and replaces the old, stale fuel with a fresh supply. It also helps to remove the oxides from the electrical switches and contacts.

### **INVERTER/ CONVERTER**

Use the inverter when shore power is not available and the generator is not going to be used as the secondary AC power source option. To turn the inverter on or off, momentarily depress the remote “on/off” button. This will supply silent AC power to most receptacles, the television and microwave. It is important to remember that use of the inverter will greatly increase house battery power consumption. Turn off the inverter when not in use to conserve house battery power.



**NOTE: The switch on the inverter unit is to remain in the ON position.**

### **Stand-by Operation**

The “stand-by” mode is activated by momentarily depressing the “on/off” inverter remote button while the unit is plugged into shore power or running from the genset. “Stand-by” mode is indicated by the remote status light. If for any reason the AC input has been discontinued to the inverter, the inverter will automatically start inverting. When AC power is resumed, the inverter will go back into “stand-by” mode.



RC8 Remote Control.



**NOTE: Remember to disable this function when not in use. It may run down the house batteries.**

## Battery Charging With The Inverter

The internal battery charger of the inverter will automatically charge the batteries when AC power is supplied to the AC input terminals of the inverter, either from shore power or from the genset. The time it takes to charge the batteries back to a full state varies greatly. It can take several hours or even days, depending on the inverter's internal setup parameters and state of charge of the batteries. Once the inverter has initiated a charge "cycle," the cycle is done in three steps. The first step is "bulk" charge. The "bulk" charge will bring the DC voltage up high, initially between 14.2-14.5 VDC, depending on conditions. The bulk charge cycle is a timed event that the inverter manufacturer has built into the inverter. The second step is the "absorb" cycle. A battery's voltage in this cycle is approximately 14.0 VDC. The length of the absorb cycle will vary with state of charge of the batteries. The final step is the "float" charge cycle. Approximately 80 percent of the charging has been completed at this time. The float charge voltage is generally around 13.3-13.7 VDC. The last 20 percent of the charge cycle of the batteries typically takes the most amount of time. The charging cycle is initiated each time the inverter is disconnected or reconnected to AC power. Repeated charging cycles in succession can lead to boiling of the batteries from a constant higher than normal DC voltage. The inverter has a "pass-through" relay that trips when AC power is supplied to the input terminals. This will pass the power through the inverter and out to the outlets, appliances or sub panel.

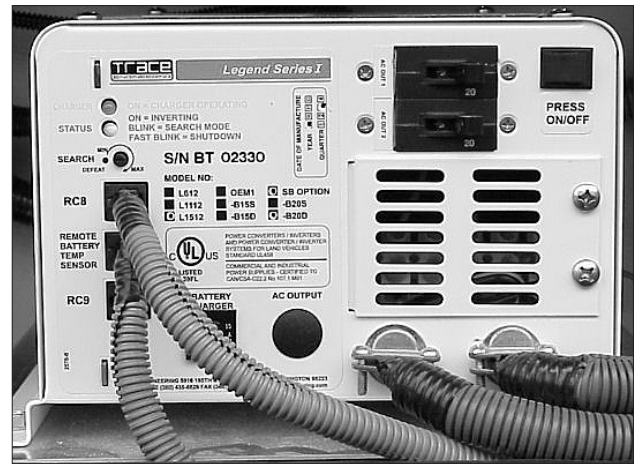

*Inverter.*



**NOTE: The inverter will still charge the batteries with AC applied regardless of the inverter's remote status.**

A ground fault circuit interrupter "GFCI" can be found in two different types of applications. One type is incorporated in a breaker used in 120 volt AC breaker panels, the other is incorporated in an outlet. The GFCI, whether it is a breaker or an outlet, offer two types of protection. One type of protection is from over-current or shorts. It also provides protection for persons against hazardous ground fault currents which can result in injury or death. Ground fault currents are currents that flow from the "HOT" or power terminal through a person to the ground. For example, touching a faulty appliance while standing

## GFCI BREAKERS AND OUTLETS

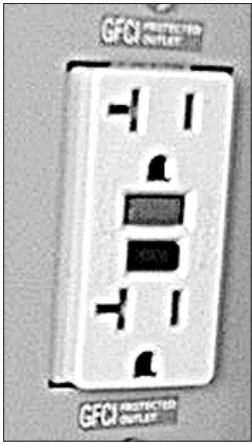

GFCI Outlet.

on or making contact with an electrical ground such as a water fixture, bath tub or the earth. If the device has been properly installed it will offer protection against the type of shock that can result from faulty insulation, wet wiring from inside an appliance, or any device or equipment plugged in or wired to that circuit. The “ground fault” portion of the outlet or breaker uses sensitive electronics inside the outlet or breaker to detect a ground fault problem. The electronics monitor the normal current of power, flowing to the “hot” or black wire through the load (eg. a light bulb or appliance) and coming back on the “neutral” or white wire. If just a small amount of the current comes back on the safety ground wire, the electronics will “trip” the breaker or outlet, stopping the flow of electricity. The amount of current it takes to trip the device from a ground fault varies slightly from the different outlet or breaker manufacturers (approximately 30 mils or less). Electrical shocks resulting from ground faults can be felt, but such a shock is considerably less than one with out ground fault protection. People with heart conditions or other conditions that make them susceptible to shocks can still be seriously injured. A GFCI outlet or breaker will not protect against shock from a normal current flow. For example, a shock from touching both metal prongs of an electrical cord or appliance while plugging it in.



**WARNING: If a breaker or outlet trips continually, DO NOT continue to reset breaker or outlet until the problem has been identified and corrected.**



**NOTE: The ground fault outlet or breaker should be tested once a month to insure it is working properly. Use the “TEST” button on the outlet or breaker. It should trip with an audible “click.” The breaker or outlet will not trip if no AC power is present to the device. If power is present and the device will not “trip,” replace it before using that circuit.**



**NOTE: One mil is 1/1000 of one amp.**

## TWELVE VOLT DC SYSTEM

A majority of the lighting and appliances are designed to operate from 12 volts DC (direct current) power. This is why the batteries play such an important role in the functioning of the motorhome. Some exceptions are with appliances such as the microwave or television. However, they still operate indirectly from 12 volts as they can be operated from the inverter. The chassis functions (engine, transmission, dash air, etc.) are also 12 volts DC.

With the growth in technology in the past several years, manufacturers have incorporated electronics into the systems. It is important to keep the 12 volt system(s) in good working order. With the incorporated electronics, these systems are voltage sensitive. Some items can be damaged if the DC voltage is not maintained within designed specifications.

There are two separate 12 volt systems. The chassis system and the house

system. These two systems, for the most part, are separate from one another. The house system does not operate engine functions; the engine system does not operate house functions. Within the two systems there is some interconnection. For example: While driving, the alternator on the engine will charge the house batteries. Likewise, while plugged into shore power or running the genset, the engine battery(s) is being charged. Each system will supply 12 volts DC power to 12 volt distribution panels. One of the 12 volt panels, located outside by the driver's side front wheel, services a majority of the chassis system functions. The other panel, located in the bedroom, services the house interior functions, such as the interior lighting and appliances. Become familiar with these panels and the items they operate.

The two different systems, engine and house, have their own set(s) of batteries. The engine battery supplies 12 volts DC power to the front distribution panel, which is located in an outside compartment by the driver's side front wheel. This panel contains mostly engine system fuses and wiring such as, headlights, tail lights, dashboard functions, gauges, etc. The house battery(s) supplies 12 volts DC power to the distribution panel, located in the bedroom. It contains fuses for the house interior lighting and appliances like the furnace and water heater.

The chassis 12 volt compartment contains fuses, relays, automatic reset type circuit breakers and diagnostic plugs for the engine, transmission and anti-lock brake system. There are two types of fuses used: "ATC" and "ATO." Both are a blade style fuse. The ATO fuses are the larger style fuse located in the front distribution panel (big fuse box). The ATC fuses are located in the two fuse boxes below the front distribution panel (FDP). It is recommended that you carry spare fuses of both types, which can be purchased from auto parts stores. Should a fuse blow, it is visible when the fuse is pulled and looked at. The wire in the middle of the plastic fuse will be broken. Bad or blown fuses must be replaced with the same amperage rated fuse and type. Replacing the fuse with a larger amp rating can damage the electrical system, the item it is operating or start a fire. If the fuse continues to blow, do not attempt to keep replacing the fuse. This is an indication there is a malfunction in the system, item or wiring. Have the problem diagnosed and corrected by a qualified technician. A fuse description label is located on the panel or lid of the fuse box.

## How Does It Work

### Chassis Distribution Panel

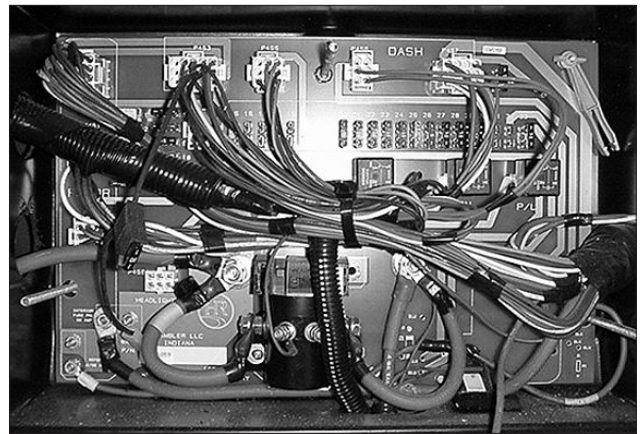

Chassis Distribution Panel.



ATO Fuse.



ATC Fuse.



## House Distribution Panel and Battery Cut-Off



Battery Cut-Off Switch.

The house distribution panel, located in the bedroom, receives power from a solenoid in the front distribution panel. The solenoid is activated by a battery cut-off switch at the entry door which allows power to transfer from the house battery to the bedroom distribution panel. The fuses are ATO type or "little fuse" (manufacturer) # 257. Spares should be kept on hand and can be purchased from auto parts stores. Replace blown fuse with same amperage rating and type. Installing higher amperage fuses can damage the wiring, the item the fuse is protecting, or cause a fire. If the fuse repeatedly blows, do not keep replacing it. Have the problem diagnosed and corrected by a qualified technician. A fuse description label is located on the distribution panel cover.

## Main Battery Disconnects

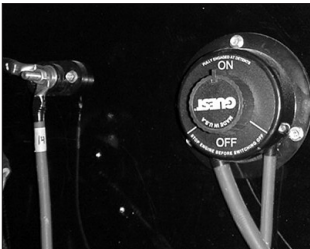

Main Battery Disconnects.

The main battery disconnects are located in the rear passenger side battery compartment. In the compartment are a pair of battery disconnects: One for the chassis batteries and the other for the house batteries. Turn off the batteries anytime the motorhome is going to be stored and not in use. If possible, leave the motorhome plugged into an AC source with the battery disconnects on. This will help prevent the batteries from going dead. Use of the battery cut-off switch at the entry door will not turn off all DC electrical items. There are small "parasitic" loads that are present on both the house and chassis batteries. Some are federal mandate items, such as the LP detector. If the motorhome will not be used or will be stored for more than 48 hours, it is recommended to turn the batteries off.

## BATTERY - HOW IT WORKS

The operation of a battery is based on a chemical reaction. The battery is comprised of lead plates and a solution of distilled water and sulfuric acid. When the solution is mixed together it is known as "electrolyte." The 12 volt battery is actually six batteries in one case. When charged, each cell has a voltage of 2.1 volts. When six cells are hooked together it makes a 12.6 volt battery (fully charged).

Electrons are stored on the negative plates. When a load (such as a light bulb) is put between the positive and negative terminals, the electrons move from the negative plate to the positive plate through the "load" and back to the ground terminal. At this time, the sulfuric acid leaves the water and adheres onto the plates of the battery. The electrolyte solution keeps the electrons from flowing internally while the battery is in the "at rest" position.

Charging the battery moves the sulfuric acid back into the solution with the distilled water. A battery left in a low or discharged state will cause the acid to "sulfate." This means that in an attempt to recharge the battery the acid has become hardened and will no longer leave the plates and enter into a liquid solution with the distilled water. The lowered acid to water ratio has a direct affect on the battery's ability to release the stored electrons (power output) and the length of time it can perform (reserve capacity). Batteries left in a dis-

charged condition can readily freeze, causing the case to crack and the solution to spill. The plates may also warp. The acid acts like an “antifreeze” for the battery. Batteries should not be left or stored in a discharged condition.

Batteries come in different sizes, types, amp hours, voltages and chemistries. There are nearly as many descriptions of batteries types and how they should be used as there are people willing to offer advice on them. There are specific guidelines you can follow that will help ensure that your batteries are well maintained.

## **Batteries**

Starting batteries are designed for high output cranking power, but not for deep cycling like the house batteries are designed to do. Starting batteries will not last long in deep cycle application. Their rating should give a good indication of their intended use. “Cold Cranking Ampere” is a measurement of amperage output that can be sustained for 30 seconds. Starting batteries use a lot of thin plates to maximize the surface area of the battery. This allows a very high starting current, but lets the plates warp when the battery is deep cycled (discharged).

## **Starting Battery**

Deep cycle batteries are best suited for use with 12 volt operated lights, appliances and inverters. They are designed to have the majority of their capacity used before being recharged. Deep cycle batteries are available in many sizes and types. The most common is a non-sealed, liquid electrolyte battery. The non-sealed types have battery caps which are able to be removed periodically to check the level of electrolytes. When a cell is low, only distilled water should be added. Water consumption will vary depending on many factors: how far the batteries are depleted, how much voltage is applied, how long the voltage is applied to charge the batteries, and how often this occurs.

## **Deep Cycle Battery**

 **NOTE: Tap water contains minerals which can alter battery chemistry and ruin the battery. Use only distilled water when refilling the battery.**

The battery electrolyte level should be checked at least once a month. Check the level sooner if frequently used. The level should be above the top of the plates, but not overfull. Most batteries have a plastic cup or well. The electrolyte level should be approximately 1/8” below the well to allow room for expansion while the battery is being charged. Over filling the battery will cause the electrolyte solution to boil or gas out of the battery cap. Remember to use only distilled water to refill the battery. A battery with a low electrolyte level will rapidly boil the water out once the plates have been exposed to air. This process may take only a matter of hours. If this has occurred, the battery is more than likely damaged.

## **Battery Maintenance**

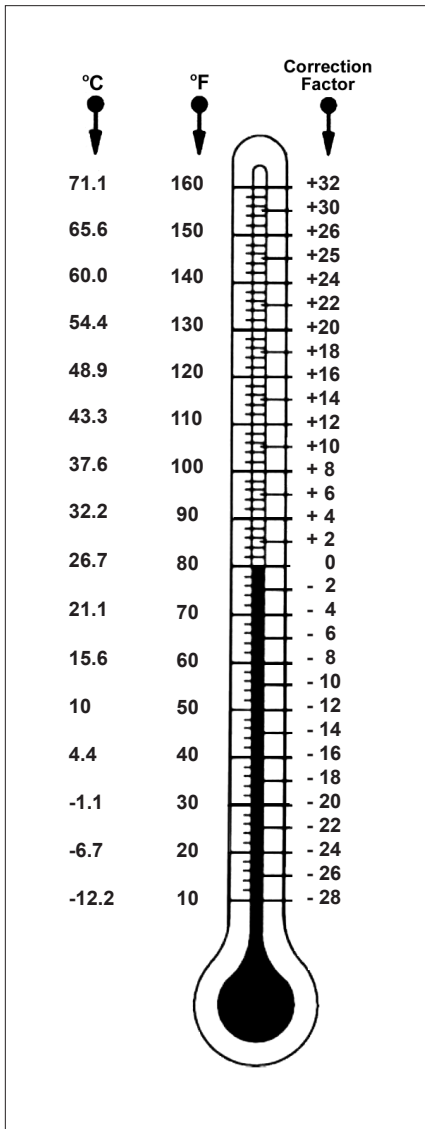

Temperature Correction Chart.

After checking the battery's electrolyte level, it is also a good time to check the battery connections for tightness and corrosion. If corrosion is found, unplug the motorhome and turn off the main battery disconnects. Disconnect the cables (marking their location) and carefully clean them with a mild solution of baking soda and water. (Aerosol products are also available for this task.) This will neutralize any acid that may be present. Do not allow the solution to enter the battery. This will damage the electrolyte balance. Use water to rinse the top of the battery area when done. Hook the cables back to the battery. Coat the terminals with petroleum jelly or an anti-corrosion grease.

The battery cable to the battery terminal connections should be metal to metal. Periodically check the batteries for corrosion. Look for cracks and check the vent plugs. Replace them if they are cracked or missing. Keep the top of the batteries clean. The accumulation of electrolyte and dirt may permit small amounts of current to flow between the terminals, which can drain the battery.



**WARNING: Liquid lead acid batteries produce hydrogen gas while being charged. This is highly explosive. Do not smoke around batteries. Extinguish all flames in the area. Batteries may explode resulting in fire, personal injury, property damage, or death.**

### Testing The Battery

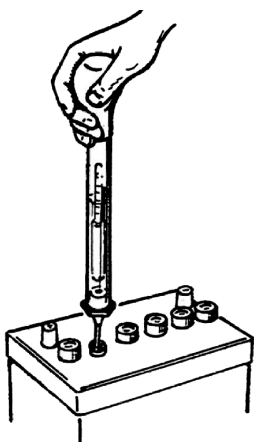

Hydrometer (Cylinder Type).

The only way to test a battery's electrolyte solution is with a hydrometer. Many styles are available, from types with cylinder graduation (shown here) to types with floating balls. These can be purchased from most auto parts stores. The hydrometer tests the battery's electrolyte solution which is measured in specific gravity (sulfuric acid to water ratio). Distilled water has been assigned a specific gravity of 1000. The hydrometer is then calibrated to this mark. Pure sulfuric acid has a specific gravity reading of 1840. This means that the acid is 1.84 times heavier than water. The electrolyte solution is about 64 percent water to 36 percent acid (fully charged battery). Hydrometers with cylinder graduation are graphed and the exact state of specific gravity can be determined.

Temperature and recent battery activity (charging or discharging) affect the hydrometer readings. It is best to check the battery when it has been "at rest" for at least three hours, although readings taken at other times will give a "ball park" figure. Using the hydrometer, draw the electrolyte solution up into the

tube. Allow the hydrometer to attain the same temperature as the electrolyte solution. Note the reading for that cell. Complete the same test for the rest of the cells on that battery bank.



**NOTE: See Temperature Correction Chart for temperature corrections.**

**NOTE: Liquid levels should be even between the cells of the battery being tested. It will affect the accuracy of the test.**

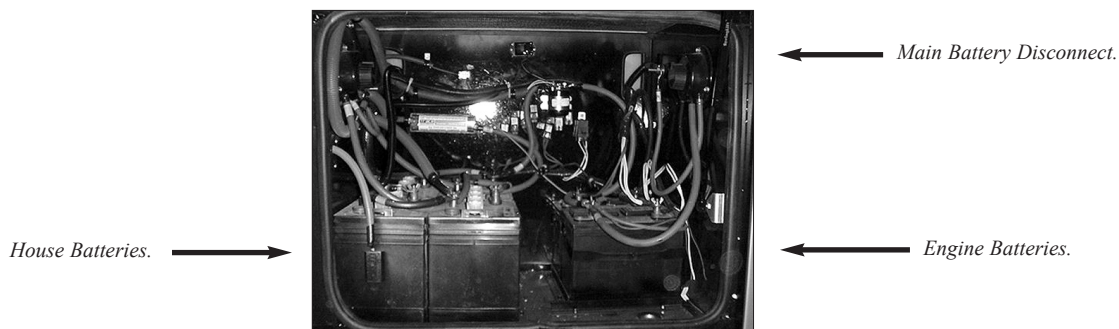

Chart readings are taken at 80 degrees Fahrenheit. Temperature affects hydrometer readings. The higher the electrolyte temperature, the higher the specific gravity reading will be. The lower the temperature, the lower the specific gravity reading will be. Add or subtract four points for each 10 degree variance from the 80 degree chart. Readings between cells should not vary more than 50 points. If one cell in a particular battery bank being tested is at a 50 percent state of charge while the others are fully charged, charge that battery to see if the low cell will come up. At the same time, do not overcharge the “healthy” cells. If the low cell does not come up after charging, the battery can damage the rest of the battery bank and should be replaced. An accurate digital volt meter + - .5% will also give an indicator of the battery’s state of charge.

Another test that can be performed is to put the battery under a specified load for a predetermined length of time, adjusted for that particular battery’s rating. The machine used for this is usually an adjustable carbon pile that can vary the load applied to the battery(s) while monitoring voltage to see if they will perform to the specific rated capacities.



**WARNING: Sulfuric acid in batteries can cause severe injury or death. Sulfuric acid can cause permanent damage to eyes, skin, and or clothing. Always wear splash-proof safety goggles when working around the battery. If battery electrolyte is splashed in eyes or on skin, immediately flush the affected area for 15 minutes with large quantities of clean water. In case of eye contact, seek immediate medical aid. Never add acid to a battery once the battery is in service. Doing so may result in hazardous splattering of electrolyte.**

## **Seven Reasons Why Batteries Fail**

### **1. Physical Condition:**

Active material flakes off the plates and falls to the bottom of the cell. This is normal, but sediment accumulates under the plates and can short out a cell. The plate separators fail to insulate positive and negative plates in a cell and the cell becomes shorted, ruining the battery.

### **2. Insufficient Electrolyte:**

Insufficient electrolyte allows exposed portions of the plates to sulfate rapidly, which reduces the battery's ability to accept a charge. Battery capacity is reduced. Accelerated erosion of the lower portions of the plates occur from higher than normal acid content due to water loss. Only water evaporates, not the acid. The battery also has a higher internal resistance when low on water. Add only distilled water. Fill each cell to the bottom of the vent well when the battery is warm. Filling a cold battery with water to the bottom of the vent well will cause overspill when the battery warms up and the plates expand. A Battery Formula For Failure: The battery has a higher internal resistance when low on water. Therefore, high resistance = more heat = a shorter battery life!

### **3. Sulfation:**

When a battery is allowed to remain discharged too long, the accumulated lead sulfate in the plate material solidifies and cannot reenter the electrolyte. The sulfate in the plates is not able to reconstitute the electrolyte to a higher specific gravity, or to restore the plate material to a more active composition.

### **4. Overheating:**

A battery operated when the electrolyte temperature reaches 125° F increases the chemical reaction. This increases the corrosion of the plates and reduces the life of the battery. When overheated, the battery plates tend to buckle and destroy the structural integrity of the battery.

### **5. Freezing:**

When the electrolyte freezes, ice forms and dislodges the active material from the plates. The battery case may crack and the electrolyte will leak out when thawed. It is especially important to keep a battery at full charge in cold weather to prevent freezing. The high specific gravity of a full charged battery doesn't freeze as easily. Never attempt to recharge a frozen battery, warm it up first.

### **6. Corrosion:**

Corrosion from spilled or splashed electrolyte forms deposits that can conduct electricity and cause battery drain. Clean off all corrosion, especially around the battery terminals and on the top cover of the battery. Prevent accumulation by coating the terminals and the exposed metal cable connectors with high temperature grease.

### **7. Overcharging:**

Overcharging rapidly converts water to gas and decreases the electrolyte's water content. As the water evaporates, the electrolyte level drops and becomes more acidic in content. This subjects the plates to a higher concentration of sulfuric acid and results in early battery failure.



**NOTE: Anytime you add more than one or two ounces per-cell per-thousand miles driven, check the motorhome charging system for overcharging.**



**NOTE: Prolonged overcharging generates excessive heat inside the battery, which buckles the plates and destroys the battery. Over 50 percent of battery failures are caused by overcharging.**

---

## **Battery Voltage and Current**

Why does the voltage on a discharged battery measure the same as a fully charged battery until the loads are applied? A simple answer to this is as follows: A battery creates electrical power by converting energy from a chemical reaction into electrical energy. As this reaction slows down, the battery voltage will drop. In a lead acid battery the electrolyte conductivity (how well electrical current can flow through) changes. The same current may be available but the rate of the reaction decreases, causing a voltage drop.

Another way of looking at this is to use the analogy of a water pump (a battery is an electric pump). The pressure in PSI that a pump delivers is like a battery's voltage. The volume of water in gallons/minute (GPM) is like the electrical current. Let's look at a 12 PSI pump with no loads (the pump is running but the outflow valve is turned off). The pump will run and the internal pressure of the pump will build up to some point higher than 12 PSI. Once the valve is opened and the water is free to flow into the loads, the pressure will drop to the rated output pressure of 12 PSI, but only if the load is not too big. If the pump is designed to maintain 12 PSI at 15 GPM, and a load demanding 20 GPM is connected, the pump will not be able to keep up and the pressure will get sucked down to a lower PSI. If the load is then reduced or removed, the pump will catch up and return to its rated 12 PSI pressure. If the pump has an infinite source of water, such as a lake or the water utility (this is like the grid, no battery), the pump will never run out of pressure. If the pump does not run out of pressure, and is operated at or below its 15 GPM level, it will hold 12 PSI.

When the tank is full, it is capable of feeding more "pressure" to the pump inlet due to gravity. The pump always has enough water available to maintain its rated pressure and volume. However, if the water tank gets low, the pump will not have enough water volume coming in to maintain 12 PSI at 15 GPM. If the loads are taken away from the pump by closing the valve on the outflow, even with low pressure in the tank, the pump will eventually pump up to 12 PSI. It will just take it longer to get there. When the valve is opened the pump will sustain 12 PSI for a brief period; however, since the tank is no longer feeding the pump as fast as needed, the pressure will eventually drop. This analogy can be restated by replacing the pump with a battery, pressure with voltage, volume with amps, the outflow valve with a switch, water with electricity and the water tank with the battery electrolyte.

The level of the tank could be thought of as the rate of the reaction taking place in the electrolyte. When the battery is fully charged, the electrolyte has an excess of reactions taking place to feed the battery terminals. This tapers off with time as the electrolyte is spent. Maintaining voltage becomes possible. With no loads, the spent electrolyte will be capable of producing close to the rated voltage. This happens after enough reactions have taken place over a period of time to bring the voltage back up. Hopefully this scenario will help to make it clear why a battery measured at rest can show close to its rated voltage, but will not run a load.

## DISTRIBUTION PANEL 110 AND 12 VOLT

The distribution panel for both the 110 volt AC and 12 volt house DC is a combination unit located in the bedroom rear overhead. This panel contains 120 volt AC circuit breakers and 12 volt DC house fuses.



**WARNING: This panel contains high voltage which can cause serious injury or death. Before beginning any work or testing procedures involving this panel, or any of the branch circuits, be sure the motorhome is unplugged from shore power, the generator is not running and the inverter is in the off position. Certain testing procedures can require the AC power to be on. Only qualified personnel or personnel with electrical backgrounds should attempt any testing procedures.**

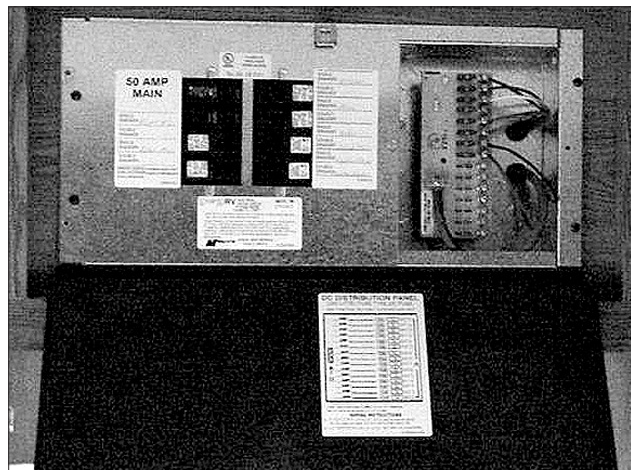

*Distribution Panel.*

### **The AC Panel**

The 120 volt AC circuit breakers receive power from the transfer switch, which is powered by either shore power or the on board generator. Power is introduced into the panel to the 50 amp MAIN breaker first, followed by power being fed to the individual branch circuit breakers. The panel label describes the breaker layout and the item, outlet or appliance to which they pertain. Branch circuit breakers supply AC power to the different items or “loads.” An electrical load is any item or device that will use current when supplied with an electromotive force. Should a breaker “trip” from over current use, or a short circuit

condition, the load to which the breaker is supplying the electromotive force should be reviewed or disconnected to determine the cause of the trip. If no cause is found, or not readily apparent, reset the breaker by toggling the breaker to the **OFF** position, then back to **ON**. Should the breaker trip again after the load is reapplied, it may indicate a fault with that particular load. Do not continue to reset breaker until the problem has been correctly diagnosed and corrected.

Breaker current ratings are current set points in which the breaker is designed to operate. The internal configuration of the circuit breaker is designed to trip when excess current is drawn through the breaker. The breaker will heat up from the excess current causing the breaker to trip. The trip action of the circuit breaker can occur within milliseconds due to the speed at which electricity can travel. Breaker ratings are set to operate on a continuous load at 80 percent of the breaker's rated capacity. For example: A breaker with a 20 amp rating will handle a continuous load of 16 amps. This designed set point is when an inductive load is applied, such as when an electric motor turns on. As the motor starts to spin, current consumption may momentarily exceed the rated capacity of the breaker. As the electric motor comes up to operating speed, the electric motor's current consumption will fall. The AC current load then falls back into the breaker's rated 80 percent set point. This electric principle should be kept in mind when using anything other than 50 amp shore service and using appliances with electric motors. When using outlets, care should be considered when applying loads such as electric motors, heaters, coffee makers, toasters, hair dryers or other large current consuming loads. If the current rating of a load is not known it is usually stated on most electrical items. The rating will either be in amps or watts. Current ratings stated on electrical items will change slightly with voltage fluctuations. As voltage increases current consumption decreases. As voltage decreases current consumption increases. This may explain why in some instances items operated at borderline voltage to current tolerances may seem fine in one location, but problematic in another.

 **NOTE: To calculate watts to amps, simply divide the watt figure by the voltage of which the item operates from. (For example: The electrical item is rated at 1370 watts. Divide that by the operating voltage of 115 volts which equals 11.913 amps.) Use this formula to calculate load to current supply ratio.**

The 12 volt fuses, located in this distribution panel, service the interior house lighting, ventilation fans, kib monitor panel, furnace and water heater. Should a fuse blow it will be evident by the broken metal strip located in the center of the fuse. Replacement fuses should be of the same amperage. If a higher rated fuse is installed it can damage the wiring. Fuse current set points follow much of the same electrical principle as the 120 volt AC breakers.

## Circuit Breakers

## FUSES

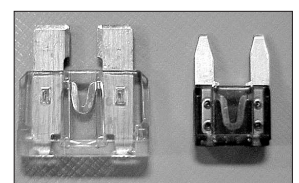

ATO Fuse.

ATC Fuse.



AMPERAGE	COLOR
1	BLACK
2	GRAY
3	VIOLET
4	PINK
5	GOLD
7.5	BROWN
10	RED
15	BLUE
20	YELLOW
25	CLEAR
30	GREEN

Amperage Chart.

Using 12 volts DC as the electromotive force can make it more susceptible to outside influences, such as corrosion from weathering or oxidation.

The large variety of applications this voltage can be used in makes it a diet staple for most of the recreational vehicle and automotive industries. The danger from shocks with this voltage is minimized, but can still occur. A good example is when a magnetic field is generated, then collapses when the power supply is cut. The result is a discharge that can reach tens of thousands of volts for a short time period. Care should be used when working with this voltage as current values can be quite high, like in the case of a battery cables. Shorting a battery cable to ground with a battery at a reasonable state of charge can result in a fire or serious personal injury from a burn.

### Tools of the Trade

One of the most widely used tools used for testing a 12 volt problem is the test light. Test lights come in a host of varieties, such as a light bulb with a probe and ground clip, to the more elaborate electronic ones that measure a wide scale of voltages and perform a variety of functions. A VOM or Volt Ohm Meter is used to perform a multitude of tests. It is generally used when exact values are needed for evaluation. These meters come in an analog or digital format. Either of these two testing tools may be used, depending upon personal preference. If a 12 volt light is not working, the test light may be better suited for this. In the case of a charging system problem, the meter may be the tool of choice. In any situation the testing tool is an invaluable piece of equipment when it comes to determining an electrical problem.

### Knowing When To Say When

Should it become necessary to use such tools, certain precautions need to be taken. You should consider three things. First, recognize when the problem is beyond your skill level. Nothing will create more mayhem than being armed with tools and going in an unknown direction. Good intentions have led to major problems. The second item to keep in mind is if something will cause more grief by being dealt with now, than if it were left alone and repaired by a professional at a more convenient time. How many times have you said to yourself, "Oh this will only take a few minutes," only to find yourself working on it for a whole day and wishing you had not touched it.

The third item to consider is whether or not the current situation may be potentially dangerous if left to be repaired at a more convenient time?



**NOTE: Check all related fuses before assuming you have encountered an electrical problem or situation.**

## CONTROLS AND INDICATORS

### Lamp Indicators

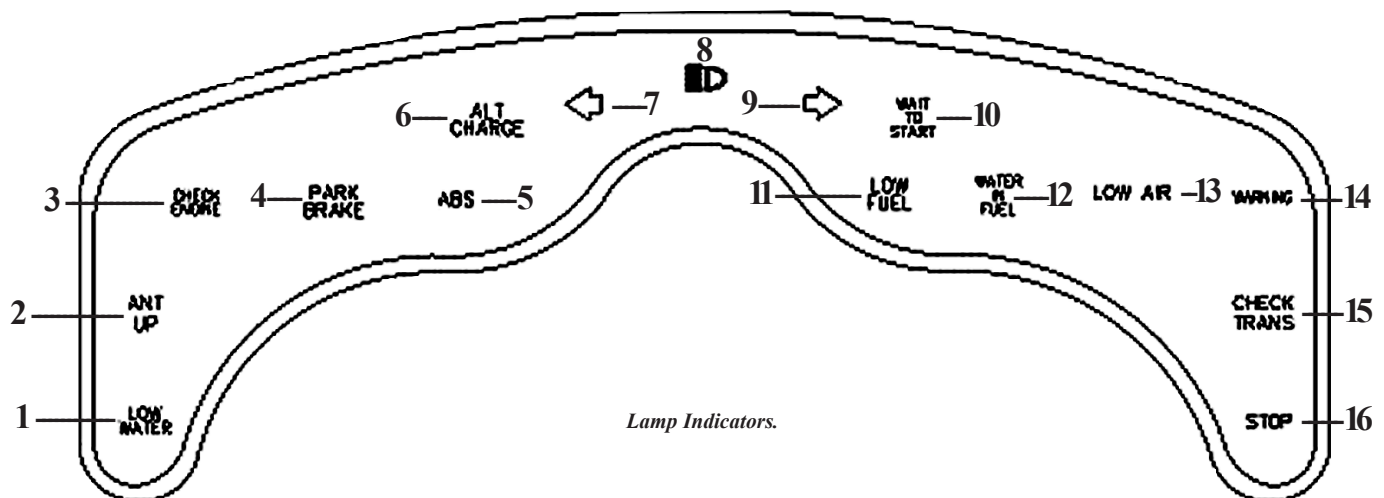

Lamp Indicators.

- 1. Low water**  
Indicates coolant level in the radiator is below acceptable level.
- 2. Ant Up**  
Indicates TV antenna is not resting flat in the storage cradle.
- 3. Check Engine**  
Indicates problems with the Cummins Engine.
- 4. Park Brake**  
Indicates parking/emergency brake is applied.
- 5. ABS**  
Indicates ABS possible fault in the ABS brake system. Also indicates faults codes for service technicians.
- 6. Alt Charge**  
Indicates a failure within the alternator charging system.
- 7. Left Turn Indicator**  
Indicates left turn indicator circuits active.
- 8. High Beam**  
Indicates high beams when illuminated.
- 9. Right Turn**  
Indicates right turn indicator circuits active.
- 10. Wait to Start**  
Monitors the intake air heater and intake manifold temperature.
- 11. Low Fuel**  
Indicates fuel level is becoming low.
- 12. Water in Fuel**  
Indicates water has been detected in the fuel system.

**13. Low Air**

Indicates air storage tank low and air systems may not operate properly.



**CAUTION: The Low Air Lamp will only illuminate when a low air indication is present. You should check the operation of the Low Air Lamp when air tank is drained.**

**14. Warning**

Indicates out of range condition exist within the engine protection circuits.

**15. Check Trans**

Alerts of problems related to the Allison Transmission.

**16. Stop**

Alerts of severe out of range condition within the engine protection circuits.

**Range Inhibited Lamp**

Indicates operation of the transmission is being inhibited and range shifts are inhibited.



Range Inhibit Lamp.

**GAUGE INFORMATION**

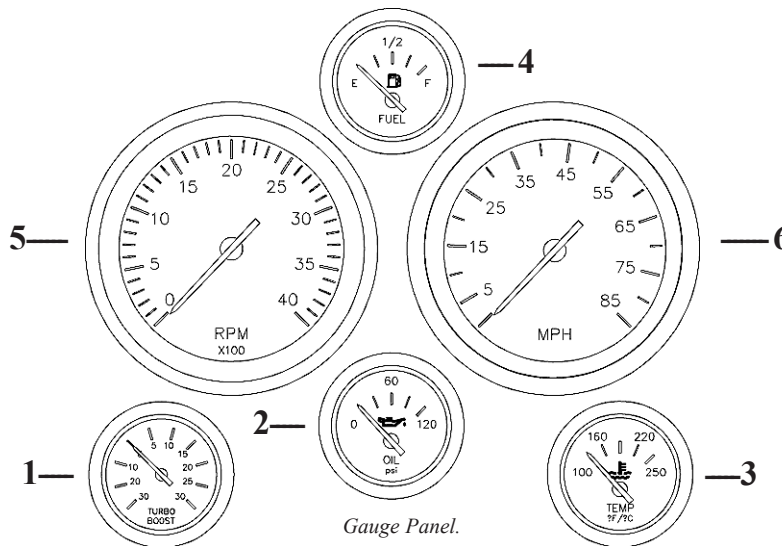

Gauge Panel.

**1. Turbo Boost Gauge**

The turbo boost gauge indicates the boost pressure produced by the engine turbocharger.

**2. Engine Oil Pressure Gauge**

Indicates the pressure of the oil and not the amount of oil in the system. Normal ranges are between 15 psi and 60 psi.

### 3. Engine Coolant Temperature Gauge

Under average conditions, the gauge will read between 160° F and 212° F. Monitor this gauge frequently when climbing hills, towing, or in high ambient temperatures. Overheating may be a result of any of the following conditions:

- Low coolant level.
- Fan failure.
- Mechanical failure of the hoses or belts.
- Something blocking the charge air cooler fins.
- Climbing a long hill on a hot day.
- Towing a heavy trailer.
- Idling for long periods of time.

### 4. Fuel Gauge

The fuel gauge will register the approximate fuel level in the tank when the ignition switch is in the run position.



**NOTE: Fuel mileage varies with driving style and road conditions. Always average more than one tankful to obtain a more accurate figure. The diesel generator system uses fuel from the main tank, and will affect fuel mileage figures. The diesel generator will not operate below 1/4 tank of fuel to insure there is enough fuel to run the main engine.**

### 5. Speedometer

Indicates the speed MPH and is located on right side of the instrument cluster.

### 6. Tachometer

Displays the engine speed in revolutions per minute (RPM). Normal low idle speed can vary from 700 rpm to 875 rpm. The tachometer reads the output pulse of the alternator. If the tachometer quits, have the alternator checked immediately.

### 7. Odometer/Trip Meter

The odometer/trip meter is located in the left portion of the dash. This meter records the mileage driven as well as keeps track of mileage on a trip. To operate the trip meter push the button labeled “trip” which changes on odometer mileage reading to the trip mileage reading. The reset button sets the trip mileage back to zero.



*Trip Meter.*

## SWITCH INFORMATION



Radio, Generator, Step In/Out Switch.

### Generator On/Off Switch

Starts and stops the generator from the dash area.

### Radio On/Off Switch

This switch enables 12 VDC to power the dash radio from the dash area.

### Step In/Out Switch

The motorhome is equipped with a sliding stepwell cover that is extended and retracted by use of a dual action air cylinder. The air cylinder is controlled by an electrically operated air valve. The air solenoid, known as a “MAC” valve receives air pressure from the front air tank. The “MAC” valve will direct the air pressure to either side of the dual action air cylinder, moving the stepwell cover in or out. The stepwell cover will not operate without sufficient air pressure (approx. 60 psi).



**Warning: Stepwell cover is under air pressure. When operating the stepwell cover be sure there are no pets, shoes or other obstructions in the stepwell area. Do not operate the stepwell cover while standing in the stepwell area.**

## Adjustment

The “MAC” air valve is located in the front of the motorhome, behind the generator door mounted to the firewall. The easiest way to identify the location is have someone operate the Stepwell Cover with the generator door open and listen for the release of air. The “MAC” air valve has two adjustment screws. The adjustment screws regulate the air flow to either side of the air cylinder. Adjusting the screws will affect the speed at which the air cylinder moves in or out.

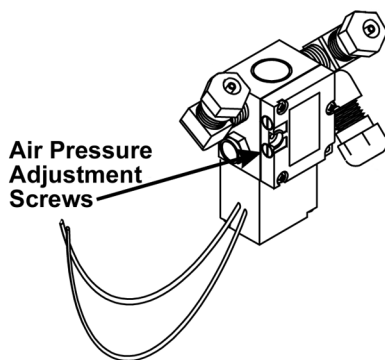

Mac Air Valve.

- Clockwise adjustment on the screw will decrease air flow.
- Counter clockwise adjustment on the screw will increase the air flow.

The front door models are equipped with a sliding stepwell Cover that is extended and retracted by two switch locations. One switch is located just inside the entry door to the right, next to the passenger seat. The second switch is located on the passenger control panel labeled **Step In/Out**.

## Switch Panel

### 1. Economy Mode Switch

This switch is used in conjunction with Allison Transmission to select secondary shift points to maximize fuel economy.

## 2. Mirror Heater Switch

This switch turns on the heaters in outside rear view mirrors. The mirror heaters should be used when defogging or deicing is needed. To use the mirror heat, press the switch to the **ON** position.



**NOTE: Mirror heat should not be left on unless continuous fogging conditions occur.**

## 3. Mirror Adjust Switch

This switch adjusts the rear view mirror. The small selector in the middle of the switch must be placed in the desired side. The middle position is to prevent accidental bumping of the switch and changing the mirror position. Your outside mirrors have been placed so that they can be easily adjusted with the Allen wrench. After taking delivery of your new motorhome it will be necessary to sit in the drivers seat and adjust the mirrors to fit your needs. Make sure you can see out of both the driver and the passenger side mirrors before driving. Adjustments to the mirrors can be made with little effort, using your left hand.

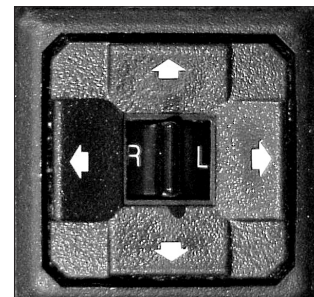

Mirror Adjust Switch.

## Care and Cleaning

After completely washing the motorhome (including the mirrors) with hot water and soap, clean the outside mirrors with a good quality glass cleaner.



**NOTE: Do not use anything abrasive on the mirror or the outside of the mirror.**

## 4. Battery Boost Switch

In the event the motorhome chassis battery has been drained and cannot start the engine, this switch momentarily “jumps” the auxiliary battery to the motorhome domestic battery to assist in starting the engine.

## 5. Engine Brake Switch

This switch activates the control solenoid for the engine brake system.

## 6. Idle Up/Down Switch

This switch will increase and decrease the engine idle in 25 rpm increments. There are limits to the idle speed, about 700 to 875 rpm.

## 7. Cruise Control Switch

This switch provides the capability of foot off the accelerator drive operation. The cruise control circuitry is incorporated in the ISB engine and controlled by the Cummins Electronic Control Module (ECM). Do not use in heavy traffic or severe weather conditions. Control of the motorhome can be lost.

## 8. Set/Resume Switch

This switch establishes the parameters for which the cruise module will oper-

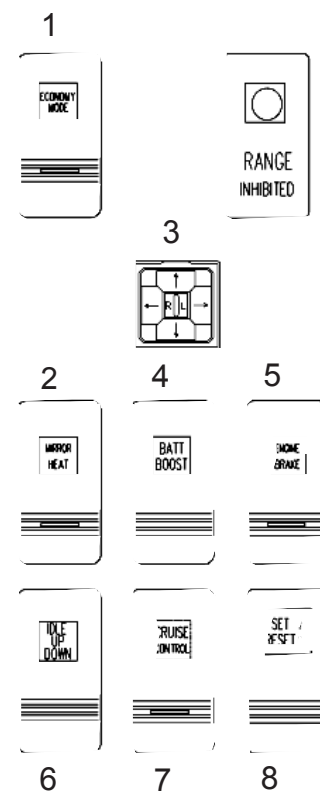

Switch Panel.

ate. Once the parameters are established they will remain in effect until either the cruise switch is turned **OFF**, or the ignition key is turned **OFF**.

The Cruise Control and Set/Resume switches are used together to provide cruise operations and can be used to control idle operations. When the Cruise is on and the Resume is pushed momentarily, the idle will jump to 200 rpm. If the Resume is pushed a second time, the idle will max out at 1,300 rpm. This is the high idle function. Both operations are cancelled when the service brake is applied. The Set switch, when pushed while driving, will store the parameter for use by the EMC. After a service brake application, speed can be restored by briefly pushing Resume. If the cruise operations are in effect, holding down the Resume switch will cause the ECU to increase the parameters.

---

### **Air Dump Switch**

Located the left side of the dash console. Will manually dump air from the air bags. May be an aid in leveling the motorhome. Releasing the air from air bags will give the leveler more range of travel for leveling.



**NOTE: Never drive the motorhome with the air bags deflated. This could damage the motorhome.**

---

### **Headlight Switch**

Pull one click to operate the parking lights. Pull two clicks to operate the headlights. Rotating the headlight switch clockwise will dim the dash lights. Counter clockwise rotation will illuminate the map light in the overhead compartment.



*Wiper/Washer. Air Dump. Headlight Switch.*

---

### **Daytime Headlight System/CSA Standard**

AL-1A is a reduced intensity low beam system, which operates low beam headlights at 80% of their normal operating voltage to prolong the bulb life. The module features a DRL indicator output, a park-brake hold-off feature, and a high-beam/taillight shut-off circuit which prevents the low beams from being operated when the master light switch is on.

AL-1A is a completely solid state, utilizing no moving parts such as relays, etc. Once two conditions have been met, the Daytime Headlight System will activate:

- 1. Ignition key on.**
- 2. Park brake released.**

---

### **Wiper/Washer Switch**

This switch is a multi-function switch which controls the speed of the wiper motor, the delay of the wiper motor and activate the washer pump motor.

---

### **Leveling Panel**

This control panel is for remote operations of hydraulic leveling system. The module consist of 4 rocker switches and 3 indicator lamps. Rocker switches are three position spring loaded switches. The center position is neutral or **OFF**.

The up position is used for the extend functions.  
The down position is for the retract functions.

Switch 1, 2, 3 control movement of the leveling jacks. Switch 4 is for power and retracting all leveling jacks.

- Green light indicates power is on.
- Red light indicates jack is extended or low fluid level.
- Amber light indicates all jacks are retracting.

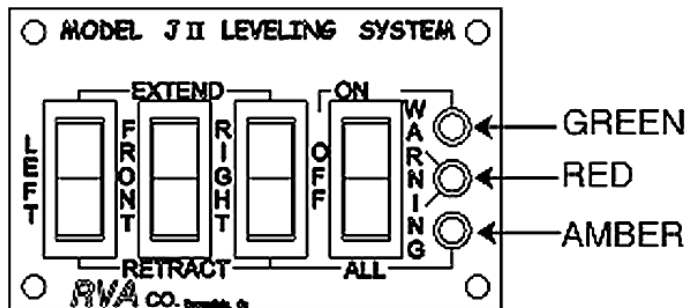

Remote Leveling Panel.

The system is designed to only provide heating, cooling and defrost capabilities for the pilot/co-pilot area only. The system is not capable of heating or cooling the entire motorhome.

## DASH A/C AND HEATER CONTROL

The blower is selected automatically when the desired feature is selected with the “select switch.” The system is shut off by placing the mode control switch in the **OFF** position.

### Blower Operation

The A/C dash system will operate in all modes except **VENT**, **FLOOR**, and **OFF**. The **A/C** and **MAX** positions engage the A/C compressor. When the switch is positioned in the **A/C** mode, fresh air is drawn through the front air intake of the unit through the A/C coil. In the **MAX** position, a damper door closes off the fresh air, while another door opens to permit only air from inside the coach to be used. When maximum cold air is desired, this position should be selected. Also use this position when you do not wish to introduce outside air into the coach.

### A/C Operation

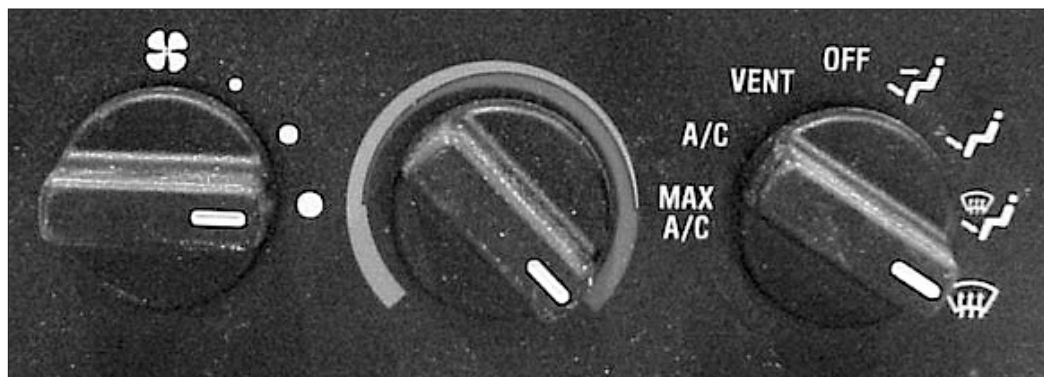

Blower Control Switch.

Temperature Control Switch.

Air Distribution Switch (Mode Control).



### **Air Distribution Switch (Mode Control)**

This switch is used to direct air where it is needed to maximize the comfort of the motorhome.

- **MAX A/C** - Recirculated air is drawn from the passenger area and discharged through the dash louvers.
- **A/C** - Fresh Air is drawn from outside into the system and discharged through the dash louvers.
- **VENT** - Fresh air is drawn in and discharged throughout the dash and defrost louvers.
- **OFF** - The blower motor does not operate. The fresh air inlet door will close, minimizing outside air infiltration into the the motorhome.
- **BI-LEVEL** - Fresh air is drawn in and discharged through the dash, floor and defrost louvers.
- **FLOOR** - Fresh air is drawn in and discharged through the floor louvers. A small amount of air is used to defrost the windshield.
- **MIX** - Fresh air is drawn in and discharged through the floor and defrost louvers. The A/C system operates to dehumidify the discharged air.
- **DEFROST** - Fresh air is drawn in and discharged through the defrost louvers. The A/C system operates to dehumidify the discharged air.

### **Temperature Control Switch**

This switch controls an electric water valve regulating the amount of engine coolant passing through the heating and cooling coils in the system. Rotating to the red area provides warmer air. Rotating to the blue area provides cooler air.

### **Blower Control Switch**

This switch controls the speed of the blower motor. This is one of the best and most effective ways of controlling the temperature. The switch will provide four speeds in all modes except **OFF**.

---

### **Operating Tips and Hints**

Air intake and discharge temperatures are greatly effected by ambient temperature and relative humidity. A large amount of cooling capacity is used to dehumidify air as well as cool it. After three to five minutes of A/C operations, the discharged air temperature should be approximately 30 degrees Fahrenheit cooler than the fresh or recirculated air entering the A/C system.

De-ice the windshield using the **DEFROST** mode. Air will heat up faster with a slower blower speed until normal operating temperature ranges are reached.

**Winter Use**

Close all windows and vents to hot, humid outside air. **MAX A/C** and **HI** blower will provide quick cool down. Lower blower speed will produce cooler air.

**Summer Use**

This dash A/C Heat system uses a combination of compressed air (developed by the chassis system), vacuum air (developed by a small vacuum generator) and electric relays and vacuum switches. Therefore, any repair can be classified in one of five categories.

**Trouble Shooting**

- Electrical • Vacuum • Air Conditioner • Heater • Defroster.

The motorhome compressed air tank must have adequate pressure to operate the vacuum generator or damper doors will not function. Also, the dash A/C Heat unit must be switched to **ON** to provide electric current to the relays, vacuum switches, etc. The dash A/C and heater system should be used monthly to keep the compressor lubricated.

The following information is provided to assist in troubleshooting common operational problems which may occur.

### **No Heating**

1. A/C switch is turned off.
2. Blower switch is turned on.
2. Verify the proper engine coolant level.
3. Verify that the engine is reaching operating temperature.
4. Verify engine coolant is reaching water valve attached to unit.
5. Verify operation of water valve to permit engine coolant to pass through valve to heater core.
6. Check unit fuses.
7. Check power supply to water valve and grounding.
8. Check wiring.
9. Engine thermostat faulty.

### **No Cooling**

1. Check blower is operating, A/C switch is in A/C or **Max** position, temperature control is turned to max cooling (blue area).
2. System fuses are not blown.
3. Condenser fan is operating.
4. Check power supply to unit and grounding of system.
5. Check wiring.

6. Coolant valve leaking.
7. Drive belt loose or broken.
8. Compressor Clutch inoperative, will not engage.
9. Expansion Valve faulty or frozen.
10. Thermostat control faulty.
11. Mode control switch faulty.
12. Compressor faulty.
13. Loss of refrigerant.

**Reduced Cooling**

1. Coolant valve not operating correctly.
2. Air passages obstructed.
3. Loose or worn drive belt.
4. Check blower and select switch.
5. Thermostat control valve faulty.
6. Expansion valve faulty.
7. Compressor faulty.
8. Low refrigerant charge.

**Blower Does Not Operate or Runs Slow**

1. Check fuses.
2. Check for loose or corroded connection.
3. Check wiring.
4. Check ignition switch is **ON**.
5. Check blower and select switch.
6. Is the motor shaft seized?
7. Is the blower wheel out of alignment?

**Damper Doors Do Not Operate**

1. Does motorhome air tank have pressure?
2. Check vacuum generator is being powered and producing vacuum.
3. Check vacuum line entering unit for vacuum.
4. Check that the vacuum solenoids mounted on unit are receiving power from the mode switch. If operating properly, the vacuum solenoid will feel hot if current is engaging the solenoid.
5. Check mode switch.
6. Check wiring.
7. Check for pinched vacuum line leading to the vacuum motor operating the damper door in question.

The function of each position of the shifter is as follows:

- **Park (P)** - Selects Park.
- **Reverse (R)** - Selects backward movement.
- **Neutral (N)** - Selects neutral.
- **Over Drive (OD)** - Selects overdrive for highway use.
- **Drive (D)** - Selects forward movement for light city traffic use.
- **Second Range (2)** - Selects forward movement for heavy city traffic use.
- **First Range (1)** - Selects forward movement for tight maneuvers and mud or snow.



**NOTE: First range provides the maximum driving torque and braking effect.**

## TRANSMISSION SHIFT LEVER



Shifter Lever.

The system is designed to provide the driver with a view of the rear of the motor home. The field of view is 140 degrees in the diagonal plane, 121 degrees in the horizontal plane, and 90 degrees in the vertical plane. Power will be supplied to the system when the ignition key is turned to the Accessory or **ON** position. The green LED will illuminate. The display on the monitor is controlled by the position of the power switch. When in the **ON** position, display is present. When placed in the **S/B** (Standby) position, display is off until the gear shift lever is set to Reverse.

### Power Switch

The switch, when **ON** (IN) position, turns on the monitor for viewing. The green LED indicator will illuminate. When the switch is **OFF** (OUT), the monitor is in a standby mode of operation. The green LED will remain illuminated when the ignition is **ON**. The monitor will display rear viewing when the transmission is shifted to Reverse.

### Camera Selector

This switch should be left in the **CA1** (OUT) position. **CA2** (IN) position is not used in the motorhome.

### Day/Night Switch

This switch should be left in the **DAY** (OUT) position for normal viewing. When set in **NIGHT** (IN), picture brightness is reduced. **NIGHT** should be used for night viewing and driving through tunnels.

### Bright Control

Clockwise rotation will increase the picture brightness. Counter clockwise rotation will decrease the picture brightness.

## REAR VIEW SYSTEM

### Monitor Controls

Green LED.



Rear View Control Panel.

### Contrast Control

Clockwise rotation will increase the picture contrast. Counter clockwise rotation will decrease the picture contrast.

### Audio Control

Clockwise rotation will increase the volume level. Counter clockwise rotation will decrease the volume level.

The camera angle may be adjusted to display a suitable rear view. The camera housing cover will need to be removed to gain access to the hexagon mounting bolts. The mounting bolts can be repositioned to the desired angle. Refasten the camera housing cover and seal using an appropriate sealant.

---

## STEERING WHEEL *Tilt and Telescope*

The tilt and telescope steering wheel control lever is located on the steering column.

- To tilt the steering wheel, pull the lever up. Tilt the steering wheel where you want it. Release the lever and it will lock the steering wheel in the new position.
- To telescope the steering wheel, push and hold the lever down. Push down or pull up on the steering wheel until the wheel is where you want it. Release the lever and the steering wheel will lock in the new position.

---

## Turn Indicator Lever/Headlight Dimmer

Turn indicator and headlight dimmer control lever is located on the steering column.

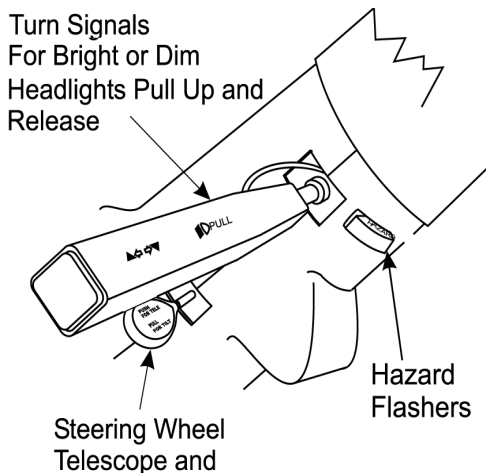

- Pushing the lever forward will activate the right turn indicator circuits when the ignition is on.
- Pulling the lever down will activate the left turn indicator circuits when the ignition is on.
- Pulling the lever up will select high/low beam circuits when the headlights are on.

---

## Hazard Flasher

The flasher button is located on steering column.

- To turn four way flasher on, pull out on flasher button.
- To shut off flasher, push button in.

## **CHAPTER 6**

---

# **UNIT CARE AND MAINTENANCE**



---

## EXTERIOR CARE

---

### ***Washing***

The life of the exterior paint finish can be extended if proper care is taken. Periodic cleaning will help preserve the paint finish. The motorhome is painted with a “base coat, clear coat system.” The clear coat is a polyurethane based material which brings out the shine or luster to the base coat paint. Care should be used when washing the motorhome. Use only mild detergents or preferred specifically designed automotive detergents. Avoid using abrasive cleansers or laundry detergents. These products may scratch the clear coat or leave a soap film. The use of specially designed automotive washing utensils, such as soft bristle brushes, are acceptable as long as they do not trap abrasive material and scratch the surface while being used. Before washing the motorhome, first try to remove most of the dirt and “road wash” that accumulates behind wheel openings, below the windshield and rear of the motorhome. If the build up is excessive, use running water over a brush and wipe in one direction. This helps to float away the “build-up” off the clear coat. Avoid back and forth or circular motions as this may act like sandpaper scratching the clear coat, leaving a haze or “swirl marks.” After removing the heavy build-up, use the mixed detergent solution to wash the motorhome. Start washing at the top of the motorhome working towards the bottom. If possible, wash the motorhome in the shade when the exterior is not hot to the touch. If necessary, turn the motorhome around to keep the area being washed in the shade. Try not to allow the detergent to dry onto the clear coat surface. Use plenty of water when rinsing.

---

### ***Drying***

Drying chamois cloth comes in natural and synthetic materials. Either type is acceptable as long as the surface is clean. Soak the chamois in clean water until all chamois material has absorbed water. Wring excess water from chamois. Start at the top and work towards the bottom. Use a downward S pattern to remove water from surface, wringing out chamois as needed. Using a chamois cloth to remove the rinse water is not necessary, but the effort can be worthwhile.

---

### ***Waxing***

To wax or not to wax? This is a good question. There are many schools of thought on this issue. The two most common thoughts are:

- The clear coat needs to “breathe.” A layer of wax will seal the clear coat not allowing it to breathe, possibly leading to failure of the clear coat.
- If the surface is not waxed, then what is protecting the surface from the environment (road salts, acid rain, road tar and ultraviolet light)?



In the past, Monaco Coach Corporation has recommended the use of wax, advocating that it be done twice a year; spring and fall. This recommendation has not changed. Many types of protective barriers are available that may be applied to the clear coat: glazes, waxes, polishes, rubbing compounds or combinations thereof.



**NOTE: When selecting a product for use, follow the product manufacturer's recommended application instructions.**

### **Glazes**

Glazes are generally used to fill very fine scratches in the clear coat, being applied either by hand or by using a polisher with a special pad.

### **Waxes**

Waxes come in many types of chemical make-ups. The popular Carnauba wax is a natural occurring wax from the leaves or fronds of the Carnauba palm tree. Mineral waxes have a paraffin base. There are also other topical application products which contain silicone.

### **Polishes**

Polishes usually contain a combination of wax based substances with an added abrasive. Like getting two products in one. Polishes can be too abrasive for clear coats.

### **Rubbing Compounds**

These types of products are generally applied by using a buffer. Use of rubbing compounds should be left to professionals as undesirable reactions can result from improper use. These types of products are generally used to correct or flatten a surface by removing high spots or small amounts of material.

When selecting a product the container should be marked "safe for clear coats or clear coat safe." Carefully follow all manufacturer's application instructions when using a product. Upon first use of a product, try it on a "small test spot" in an inconspicuous area in case an undesirable reaction occurs. Observe test area from different angles checking for hazing or swirl marks. If an abnormal finish or reaction is observed, discontinue product use and consult the product manufacturer. If the product is a paste, do not allow dried paste to be baked on by the sun. Remove paste shortly after drying. Cotton baby diapers or clean, dry, 100 percent cotton cloths are best suited for dried paste removal. Turn the cloth often for best results. Use a separate clean cloth to buff. The surface should feel "slick" when passing a cloth lightly over the finish. Avoid repeated wax applications which can cause wax build up. Some very fine scratches or swirl marks may be removed by an application of a glaze. These types of glazes fill the scratches or swirl marks.

The motorhome is a big item, with a large surface area. Washing and waxing is not going to be done in one afternoon. Pick sections to do and admire the section that is complete. If the task seems formidable, have an automotive detailer perform the task.

All chrome, stainless steel and aluminum should be washed and cleaned each time the motorhome is washed. Use only automotive approved non-abrasive cleaners and polishes on exterior bright work. Aluminum wheels should be cleaned regularly with a non-abrasive cleaner recommended for aluminum wheels. Do not use rubbing compounds.

### ***Exterior Bright Metal***



**NOTE: When using chemicals to remove road tars, use only automotive type products that are recommended for use on painted surfaces and fiberglass. Observe the warning recommendations and directions printed on the container of any agent being used.**

The motorhome is subjected to a great deal of outside influences, not always under your control. While parked, the coach is exposed to extreme temperatures, humidity, ultraviolet light, acid rain and great amounts of other organic environmental problems. While driving, the coach is subjected to twisting and flexing, going in and out of driveways, bouncing through potholes and winding mountain roads.

### ***Exterior Maintenance***

Periodic inspection of the fiberglass exterior may reveal minute cracks in the surface commonly called “spider cracks” or “hairline cracks.” These are caused by the flexing of the fiberglass exterior and are quite normal. If a crack represents a threat to the integrity of the fiberglass, it will open up so that the weave of the cloth is visible. If this happens, or if the exterior has been damaged, cover the area as quickly as possible to prevent moisture penetration, especially in freezing climates. Use plastic sheeting and tape, if necessary, so that moisture will not get into the motorhome and damage the interior.

Periodic resealing of the joints and seams is necessary to prevent the entrance of moisture into the motorhome. There cannot be enough emphasis placed on this issue. Damage caused by a water leak can accumulate very quickly. Never leave the vehicle unattended with the slide room in the out position. If the vehicle is to be stored outside over the winter months, a bi-monthly full interior inspection for water leaks should be made. Extensive sealing has been performed at the factory. However, the twisting and flexing that occurs when traveling may have compromised a seal or seam. All joints and seams should be inspected at least twice a year and recaulked as necessary. Special attention should be directed toward the roof air conditioning seals, ceiling and plumbing vents, skylights, roof mounted antennas, windows, door

### ***Seal Inspections***

molding, clearance lights and the beltline molding. Specific sealant products should be used in the areas for which they were designed. These items can be obtained from recreational vehicle parts suppliers. Listed below are some of the more common sealants and the areas in which they are used.



**WARNING: Products may contain hazardous materials which require special handling. Read labels carefully. Follow all product manufacturer's safety requirements.**

---

## Sealant Types

- **Acryl-R (Schnee-Moorehead 5504)**

This product is used on all roof openings such as vents and skylights, ladder roof mounts and any roof mounted antennas. This sealant is not used on the roof air conditioners. Sealant should be applied overlapping only where the equipment bases meet the roof. Clean old sealant that is lifting before applying with new. Make sure roof is dry and free of dirt. This product is usually found in a caulking tube. Care should be used when near an edge as product will spread out. Masking tape may be used to mask around area to avoid mishaps.

The roof air conditioners have closed cell foam base gaskets. No sealants are required. The roof air conditioners should be checked for tightness by the four mounting bolts located in each corner of the air conditioner roof opening. Torque specification is 40-50 in/lbs. Base gasket should be compressed to approximately 1/2".

- **Clear Silicone Sealant**

This product is used on the sidewalls where a hole has been made and an item installed. This includes: windows, doors, handles, beltline molding, latches and around bases of items that are surface mounted, such as clearance lights.

Old peeling sealant should be removed first. Do not use metal utensils. Use nylon sticks or equivalent to avoid scratching painted surfaces. Do not use lacquer thinners or ketone based solvents as they can damage the painted surfaces. Thoroughly, clean and dry the surface before application. Cut tube at an angle with smallest usable opening, and bead along surface. Avoid a heavy bead as a little goes a long way. Wear disposable latex gloves and use a finger at a 45 degree angle to smooth out the beaded surface. Do not moisten glove finger. Keep rags or paper towels handy for clean up. When applying silicone, use care. Plan ahead before starting a bead, looking for obstacles that may impede application.

- **Black Urethane**

This product is used for sealing the windshields. Black Urethane applies much the same as silicone. Apply the urethane by forcing the discharge nozzle under the rubber gasket. Clean up using mild solvents such as paint thinner. Gloves are required as this material is hazardous. Avoid prolonged inhalation of vapors.

- **Acrylic Sealants (geocel 2300)**

This product is used where items are sealed under a painted surface such as the metal corners of the slide out room. This material is specially formulated to allow paint adhesion

- **Spray Foam**

This product is used to seal water lines or wires where they run through a floor opening.

- **Black Seam or Tar Tape**

This is a sticky tape which comes on a roll. This product is used on the front and rear roof seams. It is also found on the roof to sidewall corners of the slide out room.

Cut away old lifting tape. Surface should be clean and dry before a new application is made. This may be done in sections as needed.

---

The most common cause of corrosion to the motorhome is the accumulation of road salts and dirt. Combine these with moisture and you have a recipe for possible early component failure. Combine this recipe with salt air and fog from being near the ocean and the corrosion process is greatly accelerated. This road wash material generally accumulates on the undercarriage, around wheel openings and the radiator charge air cooler package. Periodically these areas need to be cleaned to help prevent early component failure due to corrosion. If you drive in areas where road salts are used, the motorhome should be washed. Hose off the undercarriage area at least once a month to help minimize the corrosion process.

## **Corrosion**

High pressure washers or steam cleaners are the most affective way of cleaning off the underside and inside wheel openings. When washing, remove all road debris and mud that has accumulated. Material left behind can exaggerate the corrosion problem.



**CAUTION: Exercise caution when cleaning the radiator charge air cooler package. Damage to the fins can result when using a high pressure washer or steam cleaner. Nozzle discharge pressure can exceed 1800 psi. Avoid using high pressure steam cleaners on the exterior paint surfaces. Remove all spattered washing debris from the exterior paint surfaces as soon as possible.**

## **INTERIOR CARE**

The fabrics have been manufactured with the same quality you would expect to find in a furniture store. If abused the fabric will be damaged. Special care is needed when your motorhome is exposed to a very humid climate for an extended period of time. Cover upholstery and make sure window coverings are down to protect from any sun damage. Protect fabric from any unnecessary exposure to moisture. Sofa, pillows, dinette cushions, living area chair, driver/passenger seating, and window treatments have been treated with Scotch Guard to prevent overall water spots and soiling. Soiling may occur more frequently and items will probably need more attention than your furniture at home. Use the following guidelines for cleaning your upholstery fabrics.

- Water-based cleaners are not recommended.
- If a spill does occur, blot up the spot, do not rub it in.
- Some solvents are not recommended since they may have an adverse reaction on specific backing of your upholstery fabric.
- To prevent overall soiling, frequent vacuuming or light brushing are recommended to remove dust and grime.
- Spot clean using a mild water-free solvent or dry cleaning product.
- Clean only in a well ventilated area and avoid any product containing carbon tetrachloride or other toxic materials.
- Use a professional furniture cleaning service for an overall cleaning.

---

### ***Ceiling***

To clean the ceiling, mix a small quantity of solution, in equal parts, of warm or hot water, white vinegar, bleach, and club soda. Spritz on and blot. Do not rub.

---

### ***Leather***

#### **Spots and Spills**

Absorb excess liquid immediately with a clean cloth or sponge. Use water only if necessary. Do not use a cleaning product. If water is used, clean the entire area where the spot occurred. An example would be the entire seat cushion or the entire arm. Let it air dry. Do not dry the wet areas with hair dryers, etc.

#### **Stubborn Spots and Stains**

Use lukewarm water and a mild soap to work up a thin layer of suds on a piece of cheesecloth. Scrub the surface. Rinse with a piece of clean, damp cheesecloth. Let air dry.

Do not use saddle soap, cleaning solvents, furniture polish, oils, varnish, abrasive cleaners, soaps or ammonia water.



**NOTE: These are recommended or suggested methods of cleaning, however, the manufacturer is not responsible for damage incurred while cleaning. Always try the cleaning method in a hidden area first to test the results.**

---

### **Mini-Blinds**

- To maintain them on a frequent basis, vacuum with the brush attachment.
- There are dusting tools available on the market designed specifically for mini-blinds.
- To wash blinds, use mild soap and water. Blinds can be washed in a tub, or hung on a fence or wall and rinsed with a hose.

---

To clean the surface, use a damp cloth or sponge and a mild soap or detergent. Difficult stains such as coffee or tea can be removed using a mild household cleaner/detergent and a soft bristle brush, repeating as necessary.

If a stain persists, use a paste of baking soda and water and apply with a soft bristle brush. Light scrubbing for 10 to 20 strokes should remove most stains. Although baking soda is a low abrasive, excessive scrubbing or exerting too much force could damage the decorative surface, especially if it has a gloss finish.

Stubborn stains that resist any of the above cleaning methods may require the use of undiluted household bleach or nail polish remover. Apply the bleach or nail polish remover to the stain and let it stand no longer than two minutes. Rinse thoroughly with warm water and wipe dry. This step may be repeated if the stain appears to be going away and the color of the laminate has not been affected.

Hot pans and heat-producing appliances (such as electric skillets) set directly upon countertops can mar the product's beauty. Always use a heat shield, hot pad, or trivet.



**CAUTION: Acidic or abrasive cleaners can damage laminate surfaces. Do not use them. Drain cleaners containing lye will permanently damage any laminate surface. If you spill a drain cleaner, wipe it up immediately and rinse several times with water.**

### **Tips**

- Always rinse laminate surfaces after cleaning! Use clean water and a cloth. Failure to rinse surface after cleaning can damage a laminate surface. If even a small amount of cleaning solution remains on the surface, the moisture from cups or dishes can reactivate it and result in permanently etched scars.
- Always use a cutting board. Sharp knives will damage the surface of the Wilsonart Laminate. To keep the surface beautiful, use a non-oily furniture

spray (clean the spray off several times a year to prevent build-up).

- Hair, textile and food dyes can cause permanent stains. If the dye should happen to spill, wipe it up immediately with dish washing detergent or an all-purpose cleaner.

- Never place pots or dishes directly from the oven or burner to an unprotected laminate surface; such extreme heat can cause cracking or blistering.

- Do not work with oven cleaners on an unprotected countertop. Wipe spills away promptly and rinse several times with water.

- Rust removers contain harsh chemicals which will quickly cause permanent damage. If a spill occurs, wipe off all residue immediately, wash thoroughly with soapy water and rinse several times.

- Steel wool and other abrasive pads will damage the laminate. Don't use them for cleaning and don't store steel wool pads on your countertop: the metal can rust and leave stains.

- Toilet bowl cleaners contain harsh chemicals that can cause permanent damage. If spills occur, wipe up immediately, wash the surface with soapy water and rinse several times.

---

## ***Vinyl Furniture***

### **For Normal Cleaning:**

Most common stains can be cleaned using warm soapy water and clear water rinses. Moderate scrubbing with a medium bristle brush will help to loosen soil from the depressions of embossed surfaces. For stubborn stains, use either **Mr. Clean** or **Fantastic**, in accordance with each product's manufacturer instructions.



**NOTE: Detergents should never be used on a regular or repeated basis for normal cleaning.**

Full strength rubbing alcohol or mineral spirits may be tried cautiously as a last resort on very stubborn stains, if the above suggestions do not work. Indiscriminate use of any solvent, or solvent containing cleaner, can severely damage or discolor the vinyl. Stains may become permanent if they are not removed immediately. The procedure for removal of the more severe staining agents are outlined below.

### **Bird Excreta & Vomit Stains:**

Sponge the area with soapy water containing a diluted bleach until the stain is removed. Rinse thoroughly with clean water.

### **Urine Stains:**

Sponge them with soapy water containing a small amount of household ammonia. Rinse thoroughly with clean water.

**Surface Mildew:**

Wash with diluted bleach, and use a soft brush for stubborn growth. Rinse repeatedly with clear, cold water.



**WARNING: Powdered abrasives, cleaners containing abrasives, steel wool and industrial strength cleaners are not recommended for Morbern vinyl. Any lacquer solvent will cause immediate irreparable damage to the vinyl. Wax should never be used on any vinyl upholstery, as it will cause premature embrittlement and cracking. Dilute chlorine bleach before using. Never use full strength bleach. If flammable solvents such as alcohol, turpentine, or varsol are used for cleaning, only small quantities should be employed in a well ventilated area. Exercise proper caution by notifying any persons in the area and keep away from any ignition source. Always wear protective gloves.**

**Ballpoint Ink:**

Permanent Marker Ink spots will stain the vinyl permanently. Immediate wiping with rubbing alcohol in a well ventilated area will remove much of the stain.

**Oil-Base Paint:**

Use turpentine, in a well ventilated area, to remove any fresh paint. Dried paint must be moistened with a semi-solid, gel-type stripper to softened paint. Carefully, scrape away the paint and stripper. Rinse with soap and water.

**Latex Paint:**

Fresh paint can be wiped off with a damp cloth. Hot soapy water will normally remove dried latex.

**Tar, Asphalt:**

Remove tar or asphalt immediately, as prolonged contact will result in a permanent stain. Use a cloth lightly dampened with mineral spirits and rub the stain gently, working from the outer edge of the stain toward the center in order to prevent spreading. Rinse with soap and water.

**Crayon, Mustard, Ketchup:**

Sponge with mild soap and water. For stubborn stains that may have set, use a cloth soaked in diluted mild detergent and gently rub the stain. Any remaining stain should be washed with diluted bleach. Rinse repeatedly with cold water.

**Chewing Gum:**

Scrape off as much gum as possible using a dull knife. Rub with an ice cube to harden and make removal easier. The remaining gum can be removed



using a cloth saturated with mineral spirits (use in a well ventilated area). Rub gently and rinse thoroughly with clean water.

**Lipstick, Grease, Oil, Make-Up, Shoe Polish:**

Apply a small amount of mineral spirits with a cloth. Rub gently. Be careful not to spread the stain by smearing it beyond its original source. No time should be lost in removing shoe polish as it contains a dye which will cause permanent staining. Rinse thoroughly with water.

**Candy, Ice Cream, Coffee, Tea, Fruit, Liquor, Wine, Tanning Lotion, or Soft Drinks:**

Use lukewarm water and sponge repeatedly. Any loose material should be gently scraped with a dull knife. Any soiled area remaining after drying should be gently rubbed with a dampened cloth using a mild detergent solution. Rinse thoroughly.

**Blood, Plant Residue:**

Rub out any spots with a clean cloth soaked in cool water. For stubborn stains, use household ammonia and rinse repeatedly with a clean, wet cloth. **Do not use hot water or soap suds**, as this will set the stain.



**NOTE: Vinyl requires periodic cleaning to maintain its appearance and to prevent the buildup of dirt and contaminant's that may permanently stain or reduce the life of the vinyl if left untreated. The frequency of cleaning and procedures used depend upon the amount of use and the environmental conditions in which the vinyl is subjected to.**

---

**Wall Paper**

Time is very important when removing substances that are solvent based or contain color. Fidelity and Jolie brands do not use abrasive cleaners containing chlorine, bleach, or solvents. Always begin with a mild detergent or soap and warm water. Clean with a soft sponge. Rinse and wipe it dry. This should remove normal dirt.

---

**Satinesque  
Wallcoverings**

Any stain should be removed as quickly as possible to minimize any reaction between the staining agent and the wallcovering. Time is very important when removing substances that are solvent based or contain color.

Examples: nail polish, oil, shampoo, lacquer, enamel, paint, ink and lipstick.

Always begin cleaning with a mild detergent such as soap. If necessary, move to a stronger cleaner like household bleach, liquid household cleaners or rubbing alcohol. Before using one of the stronger cleaners, first test the cleaning agent on a small inconspicuous portion of the wallcovering to insure it does not affect the color or gloss of the wallcovering.

**Normal dirt**

Remove using a mild soap or detergent and warm water. Soak for a few minutes, then rub briskly with a cloth or sponge.

**Nail polish, Shellac, or Lacquer**

Remove with a dry cloth. Be careful not to spread the stain. Quickly clean the remaining stain with rubbing alcohol and rinse with clean water.

**Ink**

Remove immediately. Wipe with a cloth dampened with rubbing alcohol.

**Chewing gum**

Harden the gum by rubbing it with an ice cube. Carefully, pull the bulk of the gum off the surface. Remove any remaining stain with rubbing alcohol.

**Pencil**

Erase as much of the pencil mark as possible. Wipe any remaining marks with rubbing alcohol.

**Blood, Feces or Urine**

Remove these staining substances as quickly as possible. Wash the stained area with a strong soap. If the stain does not disappear, rinse the soap solution with clean water and mix a solution of equal amounts of water and household bleach. Clean the stained area with the bleach solution, rinse with clean water.

---

Remove ordinary stains with mild soap and warm water. Sponge it on. Rinse well and dry with a soft cloth.

***Tower Wallcovering***

Special cleaning problems: To remove ball point pen, blood, lipstick, etc. use a sponge or soft bristle brush and Formula 409, Fantastic or a similar product. Rinse well and dry. Finish cleaning by applying full strength isopropyl alcohol with a sponge or soft brush; rinse well and dry.

---

**Water Spots**

***Windows***

Any glass will develop water spots if the glass is not cleaned properly. A spotting effect is magnified when the glass has a reflective finish. Use a squeegee immediately after washing to reduce water spotting. To remove stubborn water stains from reflective glass we recommend Cerium Oxide Polishing Compound, made by C.R. Lawrence. It is available at most glass shops.

**Condensation**

Condensation is a natural phenomenon. The amount of condensation will vary with climate conditions, particularly relative humidity. Condensation

occurs from water vapor present in the air. Each of us add more by breathing, bathing, cooking, etc. Water vapor collects wherever there is available air space. When temperature reaches the dew point, the water vapor in the air condenses and changes to liquid form.

### Controlling Moisture Condensation

You can reduce or eliminate interior moisture condensation during cold weather by taking the following steps:

- Partially open the roof vents and windows so that outside air can circulate into the interior air. Increase the ventilation when larger numbers of people are in the motorhome. Even in raining or snowing conditions, the air outside will be far drier than the interior air.
- Install a dehumidifier. Continuous use of a dehumidifier is effective in removing excess moisture from the interior air. Using a dehumidifier is not a cure-all, however, it will reduce the amount of outside air needed for ventilation.
- Run the range vent fan when cooking, and the bath vent fan (or open the bath vent) when bathing, to reduce water vapor. Avoid excessive boiling or use of hot water, as it produces steam.
- Do not heat the motorhome interior with the range or oven. Heating with the range or oven increases the risk of toxic fumes and oxygen depletion. Also, open flames add moisture to the interior air increasing condensation.
- In very cold weather leave the cabinet and closet doors partially open. The air flow will warm and ventilate the interior of the storage compartments and the exterior wall surface, reducing or eliminating condensation and preventing possible ice formation

---

## Vinyl Flooring

The vinyl flooring in the motorhome is durable and long lasting when properly taken care of. When a spill occurs, wipe it up with a damp sponge or paper towel. Avoid using cleansers containing abrasives or scouring pads as these may damage the finish of the flooring. Keep the floor clean, as dirt, grit and soil can act as abrasives. A 100 percent latex backed floor mat may help to keep floor clean. Do not use rubber backed mats or rubber casters, as they may stain the flooring. Use large protection pads with felt spots on bases of heavy stationary items to help disperse the weight. Felt spots are non-abrasive. High, stiletto type heels may permanently damage the flooring. When moving heavy objects, lay down pieces of wood first to prevent accidental galling of vinyl.



**NOTE: Some dishwashing liquids, oil based cleaners and one step “polishes” may not be suitable cleaners for the flooring. They can leave an oily residue which attracts soil and reduces gloss.**



**CAUTION: Flooring may become extremely slippery when wet. Avoid personal injury by wiping up spills and keeping flooring dry**

---

## STAINS, SPILLS AND SCUFFS

---

### STAINS AND SPILLS

Acids, Alkalis	Fruit, Fruit Juices
Blood	Grass
Catsup, Mustard	Iodine, Mercurochrome
Cleaners, Strong Soaps	Urine, Excrement
Dye, Dye Markings	Rust
Food, Candy	

### REMEDY

Apply Congoleum Bright 'N Easy No-Rinse Cleaner, full strength, on a wet sponge. Treat stubborn stains by rubbing the area with a 10 to 1 dilution of water to liquid bleach. If rust stain does not respond, use lemon juice or a cream of tartar solution.

---

### PAINT AND SOLVENT SPILLS

Dry Cleaning Fluids	Oil Based Paints
Lacquer	Wood Stains
Latex Paints	Varnish
Nail Polish	
Solvents	

### REMEDY

Blot up excess at once. Rub lightly with a cloth dipped in mineral spirits or paint thinner\*. If paint is dry, gently peel it from the floor. Clean area with Congoleum Bright 'N Easy No-Rinse Cleaner.

---

### STAINS THAT WON'T WIPE UP

Adhesives	Grease
Asphalt	Candle Wax
Chewing Gum	Tar
Oil	

### REMEDY

Remove excess with a dull kitchen knife. (Avoid sharp instruments that could scratch the floor.) Rub lightly with lighter fluid\* on a clean cloth. Clean area with Congoleum Bright 'N Easy No-Rinse Cleaner. If floor appears dulled, apply Congoleum Bright 'N Easy Floor Polish.

---

### SCUFFS AND SMUDGES

Rubber Heel Marks  
Shoe Polish  
Scuffs

### REMEDY

Methods 1-5 are given in descending order depending on severity of scuff.

1. Spray Fantastik® Cleaner on the scuff. Let stand for 10-15 seconds, then rinse with a sponge or cloth.
2. Using a damp sponge, rub scuffed area with a polishing cleaner such as Soft Scrub®. Rinse with a sponge or cloth.
3. Wipe scuff with lighter fluid\* applied with a clean cloth.
4. With a rubbing motion, apply a car polish/cleaner such as Meguires No.7® or similar product on the area. Rinse thoroughly.
5. Remove stubborn scuffs with a mechanical buffer equipped with a lamb's wool pad.



**CAUTION:** Lighter fluid, mineral spirits and paint thinner are flammable solvents. Carefully read and follow cautionary information on label. Keep traffic off treated area for 30 minutes.

---

### REPAIR

If the stained area appears to be permanent, a patch may be possible on the sheet vinyl flooring. Contact a vinyl flooring retailer or installer about the possibility of repair. You can receive a copy of the "How To Repair" brochure by contacting Congoleum at 800-934-3567 Monday through Friday 8:30 a.m. to 5:00 p.m. EST.

# CARPET CLEANING

## Spot Removal Procedures:

- Act quickly when anything is dropped or spilled. Remove spots before they dry.
- Blot liquids with a clean, white, absorbent cloth or paper towel.
- For semi-solids, scoop up with a rounded spoon.
- For solids, break up and vacuum out as much as possible.
- Pretest the spot removal agent in an inconspicuous area to make certain it will not damage the carpet or its dyes.
- Apply a small amount of the cleaning solution recommended for the particular spot. Do not scrub. Work from the edges of the spot to the center. Blot thoroughly. Repeat until spot is removed.
- Follow steps on the Carpet Spot Removal Guide.
- After each application, absorb as much as possible before proceeding to the next step.
- Absorb moisture with layers of white paper towels, weighted down with a non-staining glass object.
- When completely dry, vacuum or brush the pile to restore texture.
- If the spot is not completely removed, contact a professional carpet cleaner.

## Cleaning Solutions

**(A) Dry Cleaning Fluid:** A nonflammable spot removal liquid, available in grocery and hardware stores.

**(B) Nail Polish Remover:** Any acetate, which often has a banana fragrance. Do not use if it contains acetone.

**(C) Detergent:** Mix two cups of cold water and 1/8 teaspoon mild liquid detergent (no lanolin, non-bleach).

**(D) Warm Water:** Lukewarm tap water.

**(E) Vinegar:** One cup white vinegar to one cup water.

**(F) Ammonia:** One tablespoon household ammonia to one cup water.

**(G) Spot Removal Kit:** Available from retail carpet stores or professional cleaners.

**(H) Call Professional:** This person may be able to give additional suggestions, have special cleaning chemicals or have the ability to patch the area.

**(I) Permanent Change:** The nature of the stain may produce permanent color loss. Either the carpet has been permanently dyed or the carpet yarns may be permanently damaged.

	A	B	C	D	E	F	G	H	I
	DRY CLEANING FLUID	NAIL POLISH REMOVER	DETERGENT SOLUTION	WARM WATER	VINEGAR SOLUTION	AMMONIA SOLUTION	SPOT REMOVAL KIT	CALL PROFESSIONAL	PERMANENT CHANGE
Use the solution specified in order from 1-6 until stain is removed.									
<b>SPOTS</b>									
Acid				2		1		3	*
Acne Medication		1		2	5	4	3	6	*
Alcoholic Beverage			1	4	3	2			*
Ammonia				2	1				*
Bleach		1	2					3	*
Blood		1	3		2	4			
Candle Wax	1					2			
Cement and Glue	2	1	3		5	4	6		*
Chalk		1	2						
Charcoal		1	2						
Chewing Gum	1								
Coffee			1	3	2		4	5	*
Cosmetics		2	1	3	6	5	4	7	*
Crayon	1		2	3					
Drain/Toilet Cleaner			2	1	3			4	*
Dye	1		2		4	3	5	6	*
Food			1	4	3	2	5	6	*
Fungicides/Insecticides /Pesticides	1		2	5	4	3	6		*
Furniture Polish (Water Base)			1	4	3	2	5	6	*
Furniture Polish (Solvent Base)	2	1	3	6	5	4	7	8	*
Furniture Stain	2	1	3	6	5	4	7	8	*
Graphite		1	2						
Grease	1		2	3			4	5	*
Ink	2	1	3	6	5	4	7	8	*
Iodine	1		2	5	4	3	6	7	*
Lipstick	2	1	3	6	5	4	7	8	*
Medicine	2	1	3	6	5	4	7	8	*
Merthiolate			1	4	3	2	5	6	*
Nail Polish	2	1	3				4	5	*
Oil	1		2	4		3		5	*
Paint	2	1	3				4	5	*
Plant Food			1	4	3	2	5	6	*
Rust			2	3	1		4	5	*
Shoe Polish	2	1	3	5		4	6	7	*
Soft Drinks			1	4	3	2	5	6	*
Soot	1		2	3				4	*
Tar	1						2	3	*
Toothpaste			1						
Urine			1		2		3	4	*
Vomit			1	4	3	2	5	6	*



**NOTE: While the recommended cleaning agents have proven to be effective, some stains may become permanent.**

---

***Fabric Cleaning Codes***

“W” - Clean this fabric with the foam only of a water- based cleaning agent to remove the overall soil. Many household cleaning solvents are harmful to the color and life of a fabric. Cleaning only by a professional furniture cleaning service is recommended. To prevent overall soil, frequent vacuuming or light brushing to remove dust and grime is recommended.

“S” - Clean this fabric with pure solvents (petroleum distillate-based products, Energine, Carbona, Renuzit, or similar products may be used) in a well ventilated room. Cleaning only by a professional furniture cleaning service is recommended.

“S/W” - Clean this fabric with the foam only of a water-based cleaning agent or with a pure solvent in a well ventilated room (petroleum distillate-based products, Energine, Carbona, Renuzit or similar products may be used). Cleaning only by a professional furniture cleaning service is recommended. To help prevent overall soiling, frequent vacuuming or light brushing to remove dust and grime is suggested.



**CAUTION: Use of water-based or detergent-based solvent cleaners may cause excessive shrinking. Water stains may become permanent and unable to be removed with solvent cleaning agents. Avoid products containing Carbon Tetrachloride, as it is highly toxic.**



**NOTE: To help prevent overall soiling, frequent vacuuming or light brushing is recommended to remove dust and grime.**

## FABRIC SPECIFICATIONS

FABRIC	CONTENT	CLEANING CODE	WHERE USED
<b>ROSE - AMBROSIA .272</b>			
Argyle Pastel	60% Cotton 40% Polyester	Dry Clean Only	Sofa, Dinette Cushion, LR Pillow, LR Valance
Anthem Cameo	71% Olefin 29% Essera (Olefin)	WS	Chair, Dining Chair, LR Pillow, LR Valance
Percheron Opal	100% Cotton	S	Bedspread, BR Pillow, Headboard, BR Valance
Supreme Satin Teaberry	69% Rayon 31% Acetate	Dry Clean Only	BR Pillow, BR Valance
<b>TAN - TUSCANY .273</b>			
Broughton 001 Backed	49% Polyester 37% Cotton 14% Rayon	S	Chair, Dining Chair, LR Pillow, LR Valance
New City Pewter Loom State	59% Cotton 41% Polyester	W	Bedspread, BR Pillow, Headboard, BR Valance
Supreme Satin Khaki	69% Rayon 31% Acetate	Dry Clean Only	BR Pillow, BR Valance
Winding Road Mushroom	54% Cotton 46% Polyester	W	Sofa, Dinette Cushion, LR Pillow, LR Valance

FABRIC	CONTENT	CLEANING CODE	WHERE USED
<b>GREEN - TRELLIS .274</b>			
28145 - A1GU Enigma Herbal	50% Polyester 48% Acetate 2% Nylon	S	Sofa, Dinette Cushion, LR Pillow, LR Valance
Avalon Sanddune	65% Rayon 35% Acetate	Dry Clean Only	Windshield
Broughton 008 Backed	49% Polyester 37% Cotton 14% Rayon	S	Chair, Dining Chair, LR Pillow, LR Valance
Lafite Marble	53% Cotton 47% Polyester	S	Bedspread, BR Pillow, Headboard, BR Valance
Supreme Satin Willow	69% Rayon 31% Acetate	Dry Clean Only	BR Pillow, BR Valance
FABRIC	CLEANING CARE	WHERE USED	
Brunswick New Oyster	Follow cleaning instructions under <b>Vinyl Furniture</b> .	Pilot Seat, Recliner	

LR = Living Room  
BR = Bedroom



## VIEW - EXTERIOR

### Rear View

1. Clearance Lights
2. Rear View Camera
3. Third Brake Light
4. Tail Light
5. License Plate
6. Rear Tow Hitch
7. Engine Compartment
8. Rear Ladder

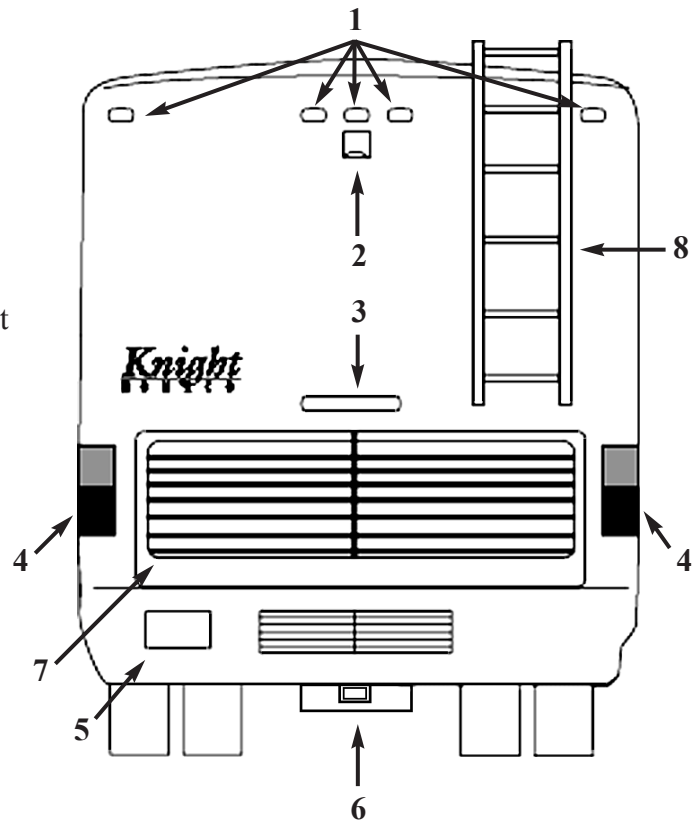

### Front View

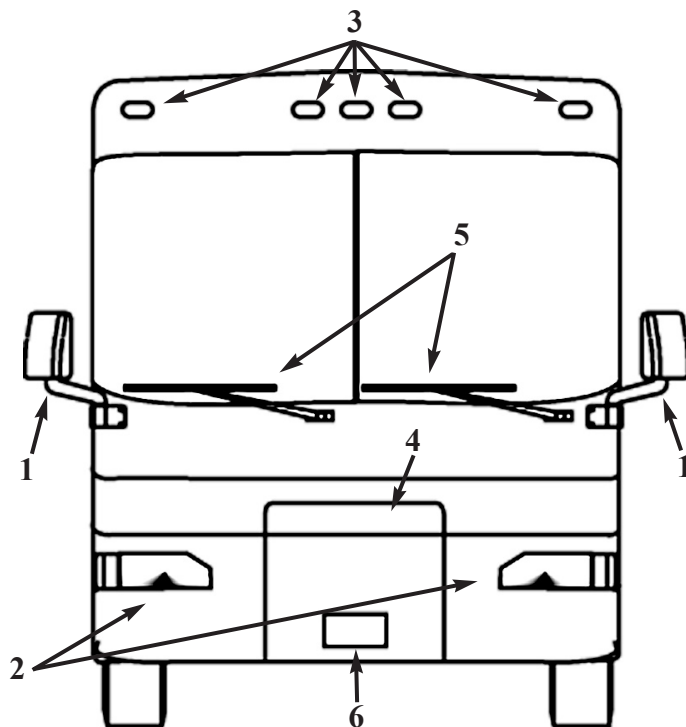

1. Mirrors (Remote Heat Optional)
2. Headlights
3. Clearance Lights
4. Generator Compartment/Front Hood
5. Windshield Wipers
6. License

**Roadside View**

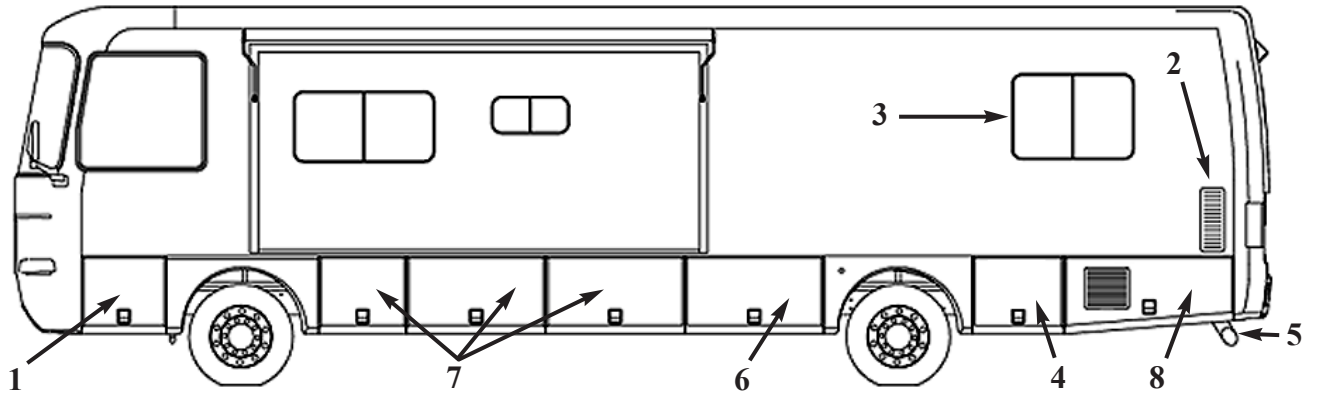

1. 12 Volt Distribution Panel
2. Air Intake Grill
3. Egress Window
4. Shore Cord, Transfer Switch, Block Heater Outlet
5. Engine Exhaust
6. Water Control Panel Service Center
7. Storage Compartments
8. Air Cleaner

**Curbside View**

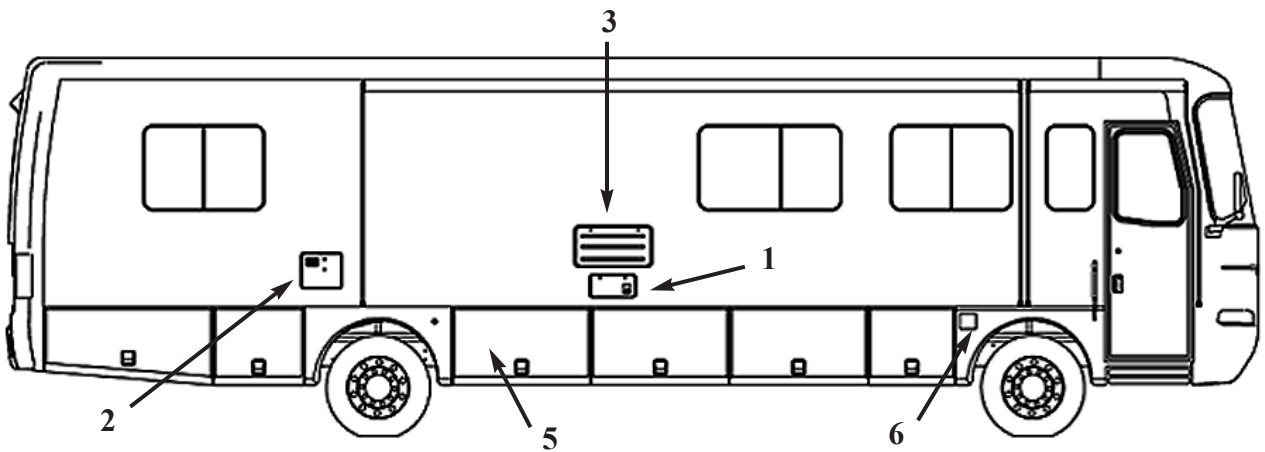

1. Furnace
2. Water Heater (Location may vary depending on floor plan.)
3. Refrigerator Vent
4. Battery Compartment
5. L.P. Fill Compartment
6. Fuel Fill

**NOTES**

---

**CHAPTER 7**  
**CHASSIS INFORMATION**



**GENERAL  
INFORMATION**

This chapter contains knowledge and information on various components of your motorhome chassis. Following the guidelines and procedures will help you to understand and operate your motorhome. Complete instructions for various components can be located in the operators manual included in the Owners Information File box.



**WARNING: When the frame or other welding is involved for motorhome repair or modification the following precautions are required to protect electronic components in the motorhome chassis:**

- 1. Disconnect the (+) positive and (-) negative battery connection, and any electronic control ground wires connected to the frame or chassis.**
- 2. Cover electronic control components and wiring to protect from hot sparks.**
- 3. Disconnect the wiring harness connectors at the transmission electronic control unit. Open bed storage compartment, open engine access door. E.C.U. is located above the transmission.**
- 4. Do not connect welding cables to electronic control components.**
- 5. The welder ground cable should be attached no more than 2 feet from the part to be welded.**

The Knight chassis has been designed by Roadmaster to provide exceptional balance, handling, and braking characteristics. The rear engine chassis is an engine and frame unit featuring a C-channel ladder rail design, providing greater structural integrity and more uniform stress distribution. Incorporated in this chassis is the Neway air suspension system using air bags and shock absorbers. The design and set up is intended to provide the smoothest ride, best handling and trouble free service, while delivering top notch drivability. The chassis also incorporates a three point hydraulic leveling system.

**CHASSIS**

The towing system incorporated in the construction of the frame is rated at 4,000 lbs towing and 400 lbs tongue weight.

**TOWING  
CAPACITY**

The Neway air suspension system uses air drawn from an air system to pressurize the air bags. The height control valves regulate the air pressure required for varying loads and maintains ride height. The suspension can provide a cushioned ride throughout the load range. It will also provide excellent side to side and axle to axle, which helps equalize and control braking.

**Suspension**

## AIR SYSTEM

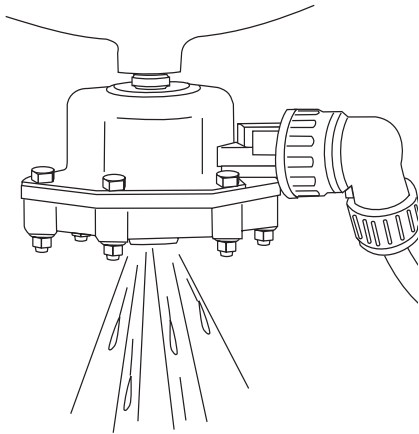

Air Purge Valve.

The chassis uses a single, dual chamber, air storage tank mounted between the c-channel rails forward in the chassis. The tank is rated at 1900 cubic inches with a maximum capacity of 150 psi. **Air is supplied to the air tank from a compressor that is part of the ISB engine. The air governor is set to maintain air pressure between 105 and 120 psi.** The tank is equipped with a pop valve, manual drain and automatic drain valve. The manual drain is located on the DRY side of the tank. The pop valve and automatic drain valve are located on the WET side. The pop valve is designed to release pressure in the tank when the pressure exceeds 130 psi. The automatic drain valve wired to the brake light circuit will activate each time the service brakes are applied, with the ignition switched to ON. This is a small amount of air/water that is expelled. This momentary release of air/water from the tank is audible. Color coded air lines help identify air system malfunctions. The air tank should be drained every 30 days. **The low air lamp will only illuminate when a low indication is present. You should check the operation of the low air lamp when the air tank is drained.** The air tank should be left open using the manual drain until all air has escaped. An additional five minutes will permit the moisture to escape. The air tank will provide air to the air bags, height control valves, parking brake and step slide cover. The air system is monitored by a low pressure air switch connected to a lamp indication on the dash console.

### COLORED AIR LINE

Orange  
Black  
Blue  
Red  
Yellow  
Green  
Silver

### ISB-260 Engine

### SYSTEM USAGE

Low Air Switch  
Height Control Valves, Front Dump Valve, Step Slide  
Rear Dump Solenoid, Park Brake Valve  
Park Brake Valve, Vacuum Generator  
Turbo Boost Gauge  
Exhaust Brake system(Jacobs)  
Air Governor

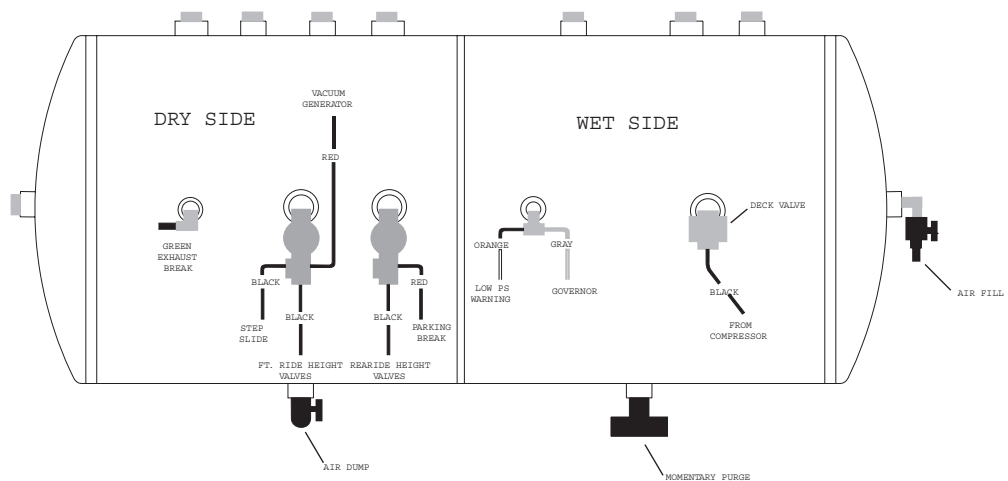

The maintenance guidelines shown below, when followed, will help with a longer life, better performance, and more cost efficient operations.

**ENGINE**

<b>ISB Engine Maintenance Schedule:</b>				
<b>Daily or Refueling</b>	<b>Every 12,000 km (7500 mi) 250 Hours, or 3 Months (3)</b>	<b>Every 24,000 km (15,000 mi), 500 Hours, or 6 Months (3)</b>	<b>Every 48,000 km (30,000 mi), 1000 Hours, or 1 Year (3)</b>	<b>Every 96,000 km (60,000 mi) 2000 Hours, or 2 Years (3)</b>
<b>Maintenance Check</b>	<b>Check/Inspect</b>	<b>Change/Replace/ Inspect</b>	<b>Check/Inspect</b>	<b>Check/Inspect/ Replace</b>
<ul style="list-style-type: none"> <li>•Check and correct</li> <li>-Engine oil level</li> <li>-Coolant level</li> <li>•Check air intake piping</li> <li>•Inspect engine</li> </ul>	<ul style="list-style-type: none"> <li>•Mounting Hardware</li> <li>•Injection pump</li> <li>•Air compressor</li> <li>•Check air intake piping</li> <li>•Check charge air cooler</li> <li>•Check air cleaner restriction</li> </ul>	<ul style="list-style-type: none"> <li>•Check antifreeze (2)</li> <li>•Change fuel filter</li> <li>•Change lubricating oil(1)</li> <li>•Change lubricating oil filter (1)</li> </ul>	<ul style="list-style-type: none"> <li>•Belt Tensioner</li> <li>•Drive Belts</li> </ul>	<ul style="list-style-type: none"> <li>•Replace antifreeze (2)</li> </ul>
<p>1. The lubricating oil and lubricating oil filter interval can be adjusted based on application, fuel consumption, gross vehicle weight, and idle time.</p> <p>2. Antifreeze check interval is every oil change or 24,000 km (15,000 mi), 500 hours, or 6 months, whichever occurs first. Must use a heavy duty year round antifreeze that meets the chemical composition of GM6038M. The antifreeze change interval is 2 years or 320,000 km (200,00 mi), whichever occurs first. Antifreeze is essential for freeze, overheat, and corrosion protection.</p> <p>3. Follow the manufacturer's recommended maintenance procedures for the starter, alternator, generator, batteries, electrical components, exhaust brake, charge air cooler, radiator, air compressor, air cleaner, freon compressor, and fan clutch.</p>				

A high grade multigrade lubricating oil is recommended for all Cummins engines. A straight weight lubricating oil is NOT recommended, and synthetic oils which meet API CG-4 or CF-4 specifications is recommended for extreme cold temperatures only. Monaco Coach Corporation uses Pennzoil 15W-40 heavy duty engine lubricating oil that meets Cummins specifications. A critical factor in maintaining engine performance and durability is the use of high grade multigrade lubricating oil and strict adherence to the maintenance service intervals.

Low viscosity oils used for winter operations will aid in starting. Synthetic oils or oil with adequate low temperature properties used for Arctic operations, where the engine can not be kept warm when shut down, will aid in starting.

The use of synthetic oils should not be used to extend drain intervals. Extended oil change intervals can decrease engine life and possibly effect the engine warranty.

Oil additives should not be used unless the oil supplier or oil manufacturer has been consulted and provided positive evidence or data establishing satisfactory performance in the ISB engine.

The use of oil analysis to extend drain interval is NOT recommended. There are numerous variables which is the basis of the recommendation.

**LUBRICATING OIL  
RECOMMENDATIONS**



## FUEL

Low sulphur #2 diesel fuel or #1 and #2 commercial winter blend diesel fuels are the most common commercially available and recommended for use. The Cummins Engine Company Inc. recommends the use ASTM #2D fuel. The use of #2 diesel fuel will result in optimum engine performance.

Fuel additives for lubricity are not recommended. There are numerous diesel fuel additives to help remove moisture from fuel, prevent microbe growth, and to prevent freeze-up during cold weather. Any fuel additives product should show supporting data for performance and benefits. Engine failures caused by incorrect fuel are **not covered under warranty**.



**WARNING: Do not mix gasoline, alcohol, or gasohol with diesel fuel. This mixture can cause an explosion.**



**NOTE: Due to the precise tolerances of diesel injection systems, it is extremely important that fuel be kept clean and free of dirt or water. Dirt or water in the system can cause severe damage to both the fuel pump and the fuel injectors.**

## COOLANT

Low silicate glycol antifreeze, either ethylene glycol or propylene glycol are recommended and combined with a good clean quality water in a 50/50 ratio. This will provide protection from -34° F to 228° F. The 50/50 mix ratio must be premixed prior to being put in the system. Placing antifreeze and water in the cooling system is not recommended. Consult the O&M manual for more details.

The coolant fluid freeze point should be checked with every oil change interval at 15,000 miles, 500 hours, or 6 months, whichever comes first. The coolant should be drained and flushed at 2 year or 200,000 mile interval, whichever comes first. **This engine does not require a “break-in” procedure.**

The oil pressure gauge, temperature gauge, warning lamps and other safety lamps should be checked daily to ensure proper operations.

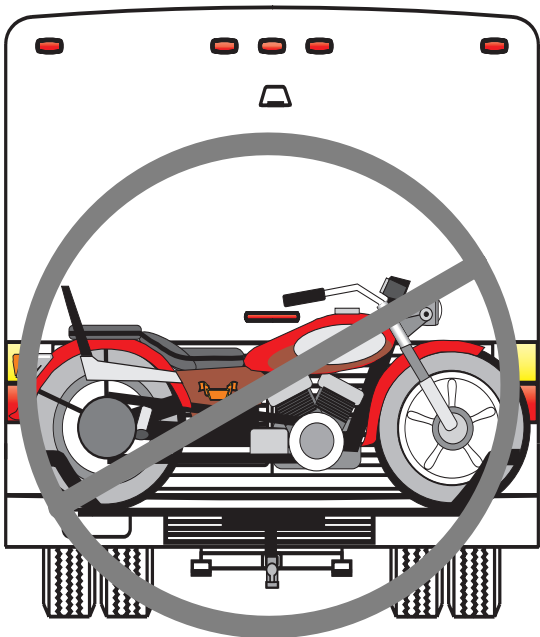

**NOTE: An over concentration of antifreeze, or the use of high silicate antifreeze, can cause damage to the coolant system and engine. Antifreeze is essential in every climate.**



**WARNING: The ISB engine is equipped with an intake air heater. Use of ether starting fluids can cause an explosion!!!**



**NOTE: Anything on the back of the motorhome which blocks the grill opening or changes the air flow may cause an overheating condition under some circumstances.**

**ENGINE PROCEDURE (NORMAL)**

When the ignition switch is placed in the ON position, the intake manifold temperature is checked to determine how long to turn on the air heater before extinguishing the “WAIT TO START” lamp. The cranking time is minimized and should not be started until the “WAIT TO START” lamp extinguishes. Once the “WAIT TO START” lamp extinguishes, the key may be turned to the START position. No pressure is required on the throttle.

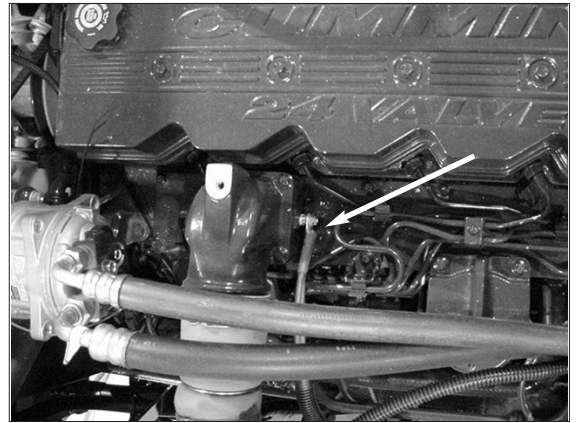

*Air intake heater location.*



**CAUTION: Do not engage the starter for more than 30 seconds. Wait 2 minutes between each attempt to start.**

If after three attempts the engine has not started, check the fuel supply system. An absence of blue or white smoke from the exhaust, during cranking indicates no fuel is being delivered.

When the engine is started, the air heater will again energize for a time period determined by the intake air temperature. Adequate oil pressure must be obtained within 15 seconds after starting. If the oil pressure gauge does not register and the check engine lamp does not extinguish, shut off the engine immediately to avoid damage. Confirm correct oil level in the pan or contact a qualified service technician.

Allow the engine to idle for 3 to 5 minutes before operating under a load. Increase the engine speed gradually to provide adequate lubrication to the bearings and to allow the oil pressure to stabilize.



**CAUTION: It is not recommended to idle the engine for long periods of time. This will simply waste fuel and will annoy neighbors at campsites. Consistent periods of long idle could cause damage to the engine.**

The engine temperature should be up to normal operating range (140 degree F / 60° C to 212° F / 100° C) before operating under full load or power.

During normal operations of the engine, look and listen. Most failures will give an early warning. Changes in performance, engine appearance, and sound could indicate the need for service or repair. Some indicators to look and listen for are unusual engine noise, excessive smoke, loss of power, and engine misfire. An increase of fuel, oil, and coolant consumption could be signs of leaks resulting in sudden changes in operating temperatures and pressures.

## ENGINE PROCEDURE (COLD WEATHER)

It is possible to operate diesel engines in extremely cold environments. The engine should be properly prepared and maintained. The correct lubricants, fuels and coolant **MUST** be used for the cold weather range for which the motorhome is being operated. Cold weather operation can be defined in two categories, Winterize and Arctic.



**REFERENCE: Refer to the Cummins Operations and Maintenance Manual for more detailed information.**

### WINTERIZE (32° to -25° F) (0° to -32° C)

Use a 50% antifreeze / 50% water coolant mixture. Use multi-viscosity oil meeting API CG-4 or CF-4 specifications 10W-30 or 10W. Fuel to have maximum cloud pour points 10° F (6 degree C) lower than the ambient temperature in which the motorhome operates.

### ARCTIC (-25 to -65° F) (-32 to -52 degree C)

Use a 60 percent antifreeze / 40% water coolant mixture, use Arctic oil meeting API CG-4 or CF-4 specifications 5W-20 or 5W-30, and fuel to have maximum cloud pour points 10° F (6° C) lower than the ambient temperature in which the motorhome operates.

## COLD WEATHER STARTING



Block heater receptacle located in driver side storage bay.

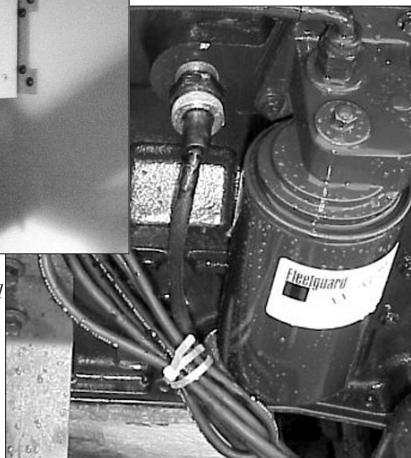

Blockheater.

The engine block heater may need to be plugged in 2 to 3 hours prior to starting. The engine block heater is 110 volts AC and requires the motorhome be plugged into shore power or have the generator running. It is not necessary to leave the block heater plugged in for long periods of time. The block heater requires about 13 amps to operate.

## SHUTDOWN EXTENDED

When the motorhome has been sitting for extended periods, 30 days or more, verify all the fluid levels are correct. Follow the normal starting procedures. If the oil pressure gauge does not register within 15 seconds, shut off the engine immediately to avoid damage. Consult the Cummins Operations and Maintenance Manual for guidelines on troubleshooting low oil pressure, or contact a qualified service technician. Allow the engine to idle for 3 to 5 minutes before operating under a load.

## **ENGINE PROTECTION SYSTEM**

General guidelines for shutting the engine down are fairly simplistic. Allow the engine to idle 3 to 5 minutes after a full load operation. This allows adequate cool down of pistons, cylinders, bearings, and turbocharger components. Under normal driving conditions, exiting the highway is generally lighter engine operation and the need for the 3 to 5 minutes is not necessary.

The ISB engine is equipped with an engine protection system which monitors critical engine temperature and pressures. The system will log diagnostic faults or codes, when an out of range condition occurs. Dash warning lamps will illuminate when the out of range conditions exist.

When using jumper cables to start the engine, make sure the cables are connected in parallel. That is positive (+) to positive (+) and negative (-) to negative (-). Always connect the positive (+) before the negative (-) and disconnect the negative (-) before the positive (+) to prevent arcing. When using an external electrical source to start the engine, shut the disconnect switch to OFF position.

In the event the motorhome runs out of fuel, the procedures involved are extensive. Contact the nearest Cummins Center or phone 1-800-DIESELS for Cummins Customer Assistance Center.

---

## **EMERGENCY PROCEDURES**

The Allison 1000 series transmission is fully automatic, torque-converter driven, electronically controlled. The electronic controls provide automatic gear selection in all drive ranges and automatic engagement of the torque converter lockup clutch.

The electronic control system is five major components. The transmission control module (TCM), engine throttle position sensor, three speed sensors, neutral start back up (NBSU) switch and control valve module. The TCU will process information received from the throttle position sensor, speed sensor, NBSU switch and control valve module. The electronic control system optimizes shift quality by using “Adaptive Shifting”. A wide variety in shifting under varied conditions will be required before optimizing the shift quality. Generally five typical shifts of a shift type is needed for shift calibration.

---

## **TRANSMISSION**

## SHIFT SELECTION

- Park (P)  
Places transmission in neutral and engages the park pawl  
turn on or turn off the engine  
longer idle periods (5 minutes)
- Reverse (R)  
back the motorhome
- Neutral (N)  
neutral operations
- Over Drive (OD)  
highway driving range 5
- Drive (D)  
city driving range 3 and 4
- Second Range (2)  
Heavy city traffic and braking on steeper downgrades
- First Range (1)  
driving very steep grades  
pulling through mud or snow  
maneuvering in tight spots

**First range provides the maximum driving torque and braking effect.**

---

### **Range Inhibited Light**

The Range inhibit lamp, located on the left dash console, is an indicator that range shifts requested may not occur. Certain operating conditions when detected by the TCM will inhibit shifting to protect from damaging operations. This is in response to diagnostic trouble codes received by the transmission control system.

---

### **Shift Inhibits**

Shift inhibits will fall within certain categories. Above-idle neutral range shifts, are shifts from N (Neutral) to R (Reverse) or N (Neutral) to a forward range when the idle is in excess of 900 RPM (Above-idle). Forward/Reverse directional shifts are not permitted when measurable output shaft speed is detected.



**NOTE: Sudden movements or lurching the motorhome with an open throttle can result in damage to transmission. Avoid this condition by making shifts only when the throttle is closed and engine is at normal idle.**

Certain unusual transmission operating conditions detected by the TCM will temporarily limit transmission operations. These conditions are transmission problems. The TCM will lock the Transmission in a safe gear range to permit the motorhome to be driven to a service location. The TCM may not respond to additional shift requests. Upshift and downshift may not occur and directional changes will not occur.

**Check Trans/Check Engine Light**

The electronic control system is programmed to inform the operator of a problem with the transmission system and automatically take action to protect the operator, motorhome and transmission. When the TCU detects a Range inhibit or Shift inhibit condition, the TCU restricts shifting, turns the CHECK TRANS light on the instrument panel and registers a diagnostic code.



**NOTE: For some problems, diagnostic codes may be registered without the ECU activating the CHECK TRANS light. Your Allison Transmission authorized service outlet should be consulted whenever there is a transmission related concern. They have the equipment to check for diagnostic codes and to correct problems which arise.**

Each time the engine is started the CHECK TRANS will light, then turn off after a few seconds. This momentary lighting is to show that the status light circuits are working properly. If the CHECK TRANS light does not illuminate during start up, or if the light remains on after start up, the system should be checked immediately.

Continued illumination of the CHECK TRANS light during vehicle operation (other than start up) indicates that the TCU has signaled a diagnostic code.

It may be possible to rock the motorhome out if you are stuck in snow, mud or deep sand. Shift the selector to D (Drive) and apply steady light throttle. Never full throttle as you may spin the wheels and bury yourself deeper. When the motorhome has moved forward as far it will go, apply and hold the service brakes. Allow the engine to return to idle before selecting the R (Reverse). Release the brake and apply light throttle until the motorhome has rocked as far it will go. Again, apply the service brake and allow the engine to return to idle. Repeat this process if the motorhome has moved a greater distance. If the process does not free the motorhome, call for towing assistance.

**Rocking Out**

**NOTE: Sudden movements or lurching the motorhome with an open throttle can result in damage to transmission. Avoid this condition by making shifts only when the throttle is closed and engine is at normal idle.**

Bring the motorhome to a complete stop using the service brakes and keep your foot on the brake pedal. Allow the engine to come to a low idle (500 to 800 RPM). Apply the parking/emergency brake by pulling up on the knob. When the parking/emergency brake is set, move the shifter to the P (PARK) position. This engages the park pawl. Remove your foot from the brake pedal.

**Parking**

**NOTE: Chock all the wheels securely if you are leaving the motorhome.**

### **Parking (continued)**

A Park Pawl is used with the transmission which effectively grounds the output shaft preventing rotation of the driveline. An attempt to engage the park pawl with the motorhome in motion will ratchet the park pawl. The park pawl will not hold the motorhome and will not engage. When the motorhome is stationary, the park pawl is automatically engaged by shifting the shift lever to P (Park). Parking on an incline and not following parking procedures can result in a condition known as “Torque Lock.” Torque lock can occur when an excessive amount of torque is placed on the park pawl. It may be difficult to shift the transmission out of P (Park). Setting the Park brake before shifting to P (Park) can help prevent torque lock.

---

### **Periodic Inspections**

For easier inspection, the transmission should be kept clean. Make periodic checks for loose bolts and leaking fluid lines. Check the condition of the electrical harnesses regularly. Check the engine cooling system occasionally for evidence of transmission fluid which would indicate a faulty oil cooler. Report any abnormal condition to your Allison dealer.

---

### **Prevent Major Problems**

Help the electronic control system oversee the operation of the transmission. Minor problems can be kept from becoming major problems if you notify an Allison Transmission distributor or dealer when one of these conditions occur:

1. The shifting feels odd.
2. The transmission leaks fluid.
3. There are unusual transmission-related sounds (changes in sound caused by normal engine thermostatic fan cycling, while climbing a long grade with a heavy load, have been mistaken for transmission-related sounds).
4. The CHECK TRANS light comes on frequently.

---

### **The Importance of Proper Fluid Levels**

Because the transmission fluid cools, lubricates, and transmits hydraulic power, it is important that the proper fluid level be maintained at all times. If the fluid level is too low, the converter and clutches do not receive an adequate supply of fluid. If the fluid level is too high, the fluid can aerate. Aerated fluid can cause the transmission to shift erratically or overheat.



**NOTE: To correctly check the transmission fluid level using the dipstick, the transmission fluid must be at operating temperature.**

---

## **SUSPENSION**

The Neway air suspension system uses air drawn from an air system to pressurize the air bags. The height control valve regulates the air pressure required for varying loads and maintains ride height. The suspension can provide a cushioned ride throughout the load range. It will also provide excellent side to side and axle to axle, which helps equalize and control braking.

Each axle has two Firestone air bags and two Monroe shocks to provide the smoothest ride, best handling, and top notch drivability. The suspension control arms bushing require no lubrication. The suspension ride height is preset and will maintain proper ride height automatically throughout the load range.

Improper ride height adjustment could result in a poor ride or damage to the suspension, thus leading to erratic coach handling. The air bags, shock absorbers, control valves, and link assemblies should be visually checked as part of pre-trip and safety inspections. This should be done on a level surface, allowing two minutes after the low air lamp extinguishes.

Listed below are items that can be checked when the motorhome is in for periodic maintenance.

### ***Preventative Maintenance Checklist***



**NOTE: Never attempt to service the air suspension on a motorhome with the air bags inflated.**

- Inspect the O.D. of the air springs. Check for signs of irregular wear or heat cracking.
- Inspect the air lines to make sure contact doesn't exist between the air line and the O.D. of the air springs. Air lines can rub a hole in an air spring very quickly.
- Check to see that there is sufficient clearance around the complete circumference of the air spring while at its maximum diameter.
- Inspect the O.D. of piston for buildup of foreign materials. (On a reversible sleeve style air spring, the piston is the bottom component of the air spring.)
- The correct ride height should be maintained. The specified ride height has been established by Monaco and set at the factory. This measurement can be checked with the vehicle loaded or empty.
- The leveling valves (or height control valves) play a large part in ensuring that the total air spring system works as required. Clean, inspect and replace if necessary.
- Check shock absorbers for leaking hydraulic oil and a worn or broken end connector. If a broken shock is found, replace it immediately. The shock absorber will normally limit the rebound of an air spring and keep it from overextending.
- Check the tightness of all mounting hardware (nuts and bolts). If loose, tighten. Do not over-tighten.



## STEERING AXLE

### 5,000 mile inspection(initial)

Bolts and nuts for proper torque; suspension ride height within 1/4"; air bags for equal firmness.

Nut air spring mounting hardware  
(top and bottom) torque 35 ft. lbs.

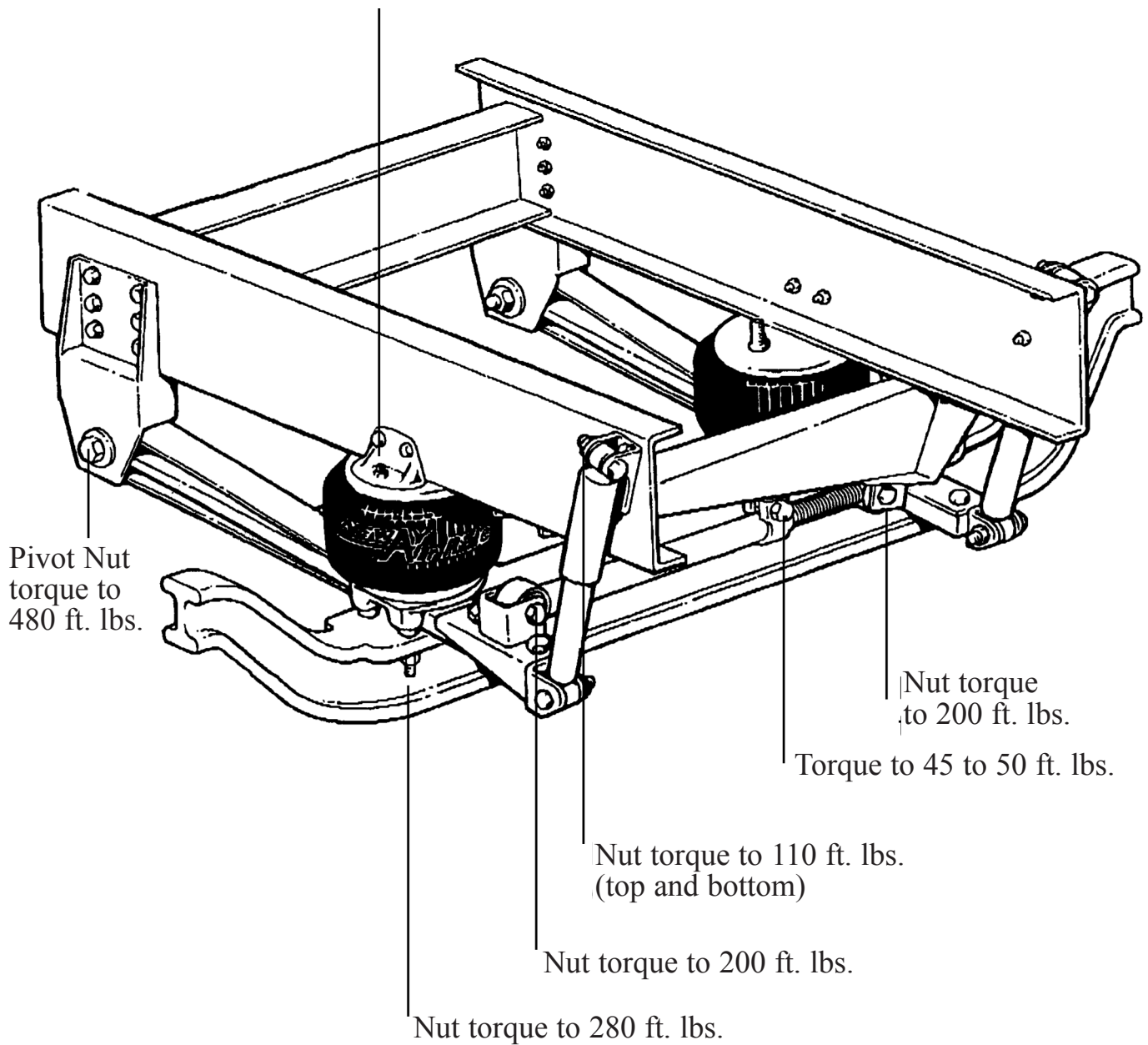

## DRIVE AXLE

### 50,000 mile or 1 year

Same as the 5,000 mile. Also, all other suspension components for any signs of damage, looseness, wear or cracks.

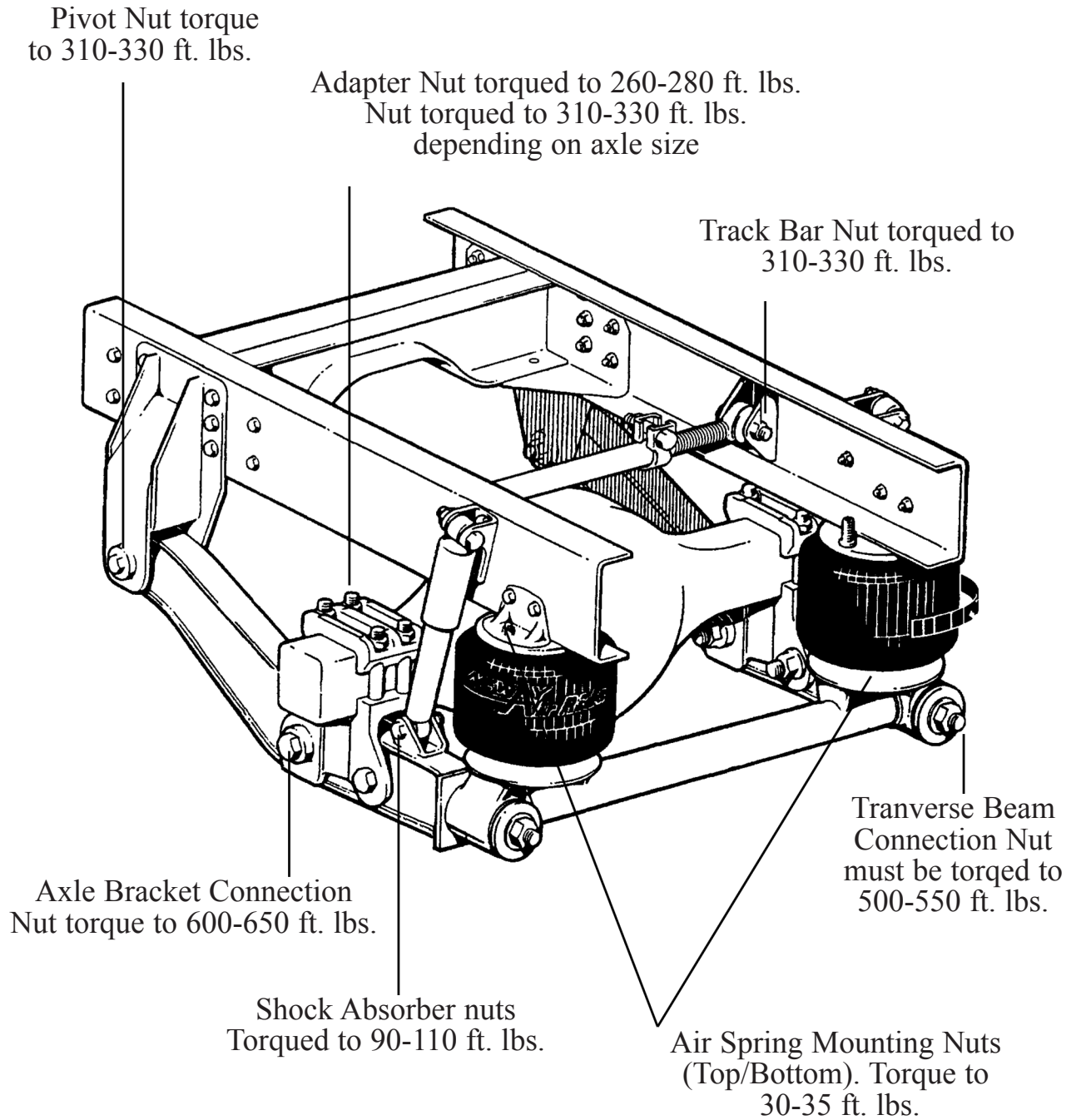

## AIR RIDE SUSPENSION

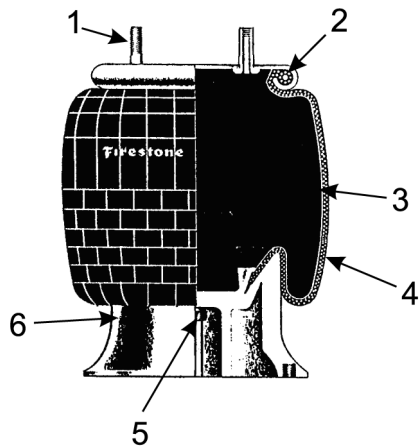

*Air Spring (Bag).*

Air ride springs, referred to as air bags, are the Firestone single convolution type.

1. **Stud.** Manufactured as a permanent part of the bead plate assembly for maximum strength and durability. Used to attach the spring to the vehicle's suspension.
2. **Bead Plate.** Crimped onto the bellows at the factory for a durable design and maximum quality control. Allows 100% leak proof testing prior to shipment.
3. **Bellows.** "Air bag" includes four plies of material: an inner layer, two plies of cord-reinforced fabric and an outer cover. Natural rubber construction provides functional properties to -65°F.
4. **Bumpers.** A solid rubber or engineered plastic device designed to prevent significant damage to the vehicle, or suspension in the event of a sudden loss of air pressure in the spring.
5. **Piston.** Provides a lower mounting arrangement for the air spring. Controls characteristics of the spring under changing pressure loads.
6. **Piston Bolt.** Attaches the piston to the bellows. Sometimes it is extended as a means of attaching the spring to the vehicle suspension.

### Cleaning

The approved cleaning method is to use soap and water, methyl alcohol, ethyl alcohol and isopropyl alcohol. Unapproved cleaning methods include all organic solvents, open flames, abrasive and direct pressurized steam cleaning.

### Ride Height Adjustment

The chassis has three height control valves. The drive axle suspension ride height is the distance from the underside of the C-Channel Rail to center line of the axle. Comparing this measurement to the height of the air bag will ensure an accurate adjustment. The steer axle suspension ride height is the distance from the underside of the C-Channel rail to the top of the axle. The air bag height measured from the top plate to the bottom plate should be 10.5". In order to obtain the ride height measurement for the rear axle, measure from the underside of the C-Channel Rail to the center line of the axle. The ride height measured for the drive axle should equal 7.5". Front axle ride height measured should equal 9.5".



**NOTE: Ride height has  $\pm 1/4$ " tolerance.**

---

## TIRES & WHEELS

The tire designed for your RV is a very technical and precisely engineered product. To obtain the maximum use and best service out of your tires, it is helpful to understand the function of a tire. A tire is a “container” that holds air. It is the combination of air and tire that supports the motorhome and its contents. In addition, since the tire is the only contact that the motorhome has with the road surface, it must provide other functions such as traction for moving, stopping, steering and providing a cushion for the motorhome.

---

The most important factor in maximizing the life of your tires is maintaining proper inflation. Driving on any tire that does not have the correct inflation pressure for the load of the motorhome is dangerous and may cause premature wear, tire damage and/or loss of control of the motorhome.

### ***The Importance of Air Pressure***

A tire that is underinflated will build up excessive heat that may go beyond the prescribed limits of endurance of the rubber and radial cords. This could result in sudden failure. A tire that is underinflated will also cause poor motorhome handling, rapid and/or irregular tire wear and an increase in rolling resistance which results in a decrease in its fuel economy.

Over inflation will reduce the tire’s footprint or contact patch with the road, thus reducing the traction, braking capacity and handling of the motorhome. A tire that is over inflated for the load will also contribute to a harsh ride, uneven tire wear and will be more susceptible to impact damage.

Maintaining correct tire inflation pressure for each loaded wheel position on your motorhome is of the utmost importance and must be a part of regular motorhome maintenance.

---

Federal law requires that the tire’s maximum load rating be molded into the sidewall of the tire. If you look on your tire’s sidewall you’ll see the maximum load allowed for the size tire and load rating, and the minimum cold air inflation pressure needed to carry that stated maximum load. Utilizing less air pressure means a lesser load can be carried by the tire. The chart on the next page shows weights that can be supported by various air pressures.

### ***How Much Air Should I Carry In My Tires?***

The amount of air pressure you need to use is dependent on the weight of your fully loaded motorhome.

---

The G.V.W.R. (Gross Vehicle Weight Rating) and G.A.W.R. (Gross Axle Weight Rating) stickers on your RV (normally located on the support pillar next to the driver’s seat) will show you the chassis manufacturer’s and/or the RV manufacturer’s total vehicle maximum weight ratings and per axle weight rating.

### ***How to Determine Your RV’s Correct Weight***

The G.V.W.R. is the maximum total weight for which the motorhome is rated-including passengers, fluids, and cargo. The G.A.W.R. is the maximum for which a single axle is designed. These per axle and total maximum weight

ratings could be limited by the tires, wheels, axle and axle bearings, the motorhome frame or other components of the motorhome.

The G.A.W.R. sticker is only a guide in knowing your maximum loaded axle weights, and subsequently your correct tire inflation pressure. Every RV, even of the same make and model, will vary in actual loaded axle weights because of different options and personal loads.

While your actual, loaded axle weight should be below the G.A.W.R., you must weigh your RV in a loaded condition to know its actual weight. Weigh the front axle, the total unit and then the rear axle. It is possible for a motorhome to be within the G.V.W.R. yet overloaded on an axle. It is even possible for one wheel position to be overloaded, even though the G.A.W.R. has not been exceeded. For this reason (if there is room to the sides of the scales) weigh each wheel position of the motorhome. This will give you a clear indication of exactly how the weight of your RV is distributed. The Tire Industry Safety Council provides instructions on how to weigh your motorhome by wheel position. These instructions and diagrams are presented on the following pages. Once you know the total weight, and the weight on each axle, the tire load data chart in this manual will show you the correct cold inflation pressure per tire for each axle.

### Where to Weigh Your Motorhome

There are probably several certified public scales in your area. You will find public-access scales in a variety of places, such as moving and storage lots, farm suppliers with grain elevators, gravel pits, recycling companies and large commercial truck stops.

If you are not aware of a nearby public scale, check your area telephone book yellow pages under the “scales-public” section or “weighers.” A nominal fee will be charged, but this is money wisely spent.

### How to Weigh Your RV

Your RV must be weighed fully loaded. That is, with passengers, food, clothing, fuel, water, propane, supplies, etc. Any towed vehicle (car/pickup, boat or trailer) or item loaded on brackets on the back of the RV, such as bikes or motorcycles, should also be included in the weighing.

## INFLATION AND WEIGHING

PSI Cold		70	75	80	85	90	95	100	105	110	115
255/70R22.5	Dual	3585	3765	3970	4110	4275	4410	4455	4610	4675(G)	5070(H)
	Single	3815	4005	4190	4370	4550	4675	4895	5065	5205(G)	5510(H)

Weight/Inflation Pressure

To accurately determine the proper inflation pressure, the motorhome should be weighed after it has been fully loaded. First, position the front wheels on the scale and take a weight reading. Divide this reading by 4 to determine the load carried by each tire/wheel. Next position the rear drive wheels on the scale and take the weight reading. Divide this reading by 4 to determine the load carried by each tire/wheel to determine proper tire pressure.

**When to check  
your RV Tire's  
Air Pressure**

Now that you have found what the correct air pressure per axle needs to be for your RV, you need to know when to check your air pressure. You should check the air pressure every two weeks or at least once a month, and before any major trip. Your RV tire air pressure should be checked every “drive” morning on long trips. On short trips, driving a day or less, your tires should be checked before you leave on your trip and again before you start your trip home. If your motorhome is stored for any length of time, air pressure should be checked prior to storage, but more importantly, when it comes out of storage.

Check your tires when they are “cold” and have not been driven for more than one mile. The stated load capacity for a given cold inflation pressure is based on ambient outside temperature. If you must check your tires when they are warm or hot, do allow for a slight increase in air pressure and make sure they are within a couple of pounds of each other on the same axle. Never let air out of a hot tire.

To maintain the inflation pressure in your tires you will need the proper equipment. It is recommended you purchase a quality truck tire air gauge which has an angle dual head. This type of gauge allows you to check inflation on the inner dual wheel which has the valve stem pointing toward you, and on the outer wheel which has the valve stem pointing away from you. Nothing should restrict your ability to check your tire’s air pressure daily when you are driving your RV. Pressure sealing valve caps should always be used to prevent air from escaping from the valve stem. If you use valve stem extension hoses, make sure they are good quality stainless steel braid reinforced and are securely anchored to the outer wheel. If your RV has a wheel cover which must be removed to check the inflation, consider removing them as the extra time and effort required may lead you to avoid checking your air pressure.

Optimum tire performance is achieved with proper inflation pressures for the loads being carried. The air pressure of all tires should be checked and corrected prior to travel, or daily if in full time use. An accurate tire gauge should be used to check the cold tire pressure. Cold tire pressure can be defined as a tire that has set for three or more hours, or a tire that has been driven less than one mile.

Proper inflation pressure should be determined after the motorhome has been fully loaded and weighed. Divide the steer axle weight by 2 when determining the load carried by each of the front tires. The drive axle weight is divided by 4 when determining the load carried.

Tires of different patterns should not be mixed on the same axle. The difference in tractive force could cause rear end gear fight and mechanical damage to the drive train. Tires of different size or construction must never be mixed on the same axle.

**Higher than recommended pressure can cause:**

- Hard ride
- Tire bruising or carcass damage
- Rapid tread wear at center of tire

**Lower than recommended pressure can cause:**

- Tire squeal on turns
- Rapid and uneven wear on the edges of the tread
- Tire rim bruises and rupture
- Tire cord breakage
- High tire temperatures
- Reduced handling
- High fuel consumption

**Unequal tire pressures on same axle can cause:**

- Uneven braking, swerve of acceleration
- Steering lead, torque steer
- Reduced handling

---

***Tire Rotation***

The useful tire life of your tire is achieved by the uniform wear for all tires. This can be increased with tire rotation. The first tire rotation is the most important. **The tire rotation pattern used for your motorhome should be evaluated by your Goodyear Tire Center.** Any unusual or unique wear pattern which may have developed should be evaluated before rotation. Misalignment, imbalance, or other mechanical problem may exist and will need correction prior to rotation.

The tire rotation should be performed every 6,000 to 8,000 miles, or at any sign of uneven wear. After a tire rotation, the inflation pressures should be checked and adjusted for the actual loads of the wheel position accordingly.

Tires are covered by Goodyear warranty. Monaco Coach Corporation is not responsible for tire wear.

## WHEEL ALIGNMENT

The correct wheel alignment promotes longer tire wear and ease of handling while minimizing the strain on the steering system and the axle components.

### Camber

Camber, as shown below, is vertical tilt of wheel as viewed from the front of the vehicle. This is machined into the axle when manufactured and is not adjustable.

“Positive” camber is an outward tilt of the wheel at the top.

“Negative” camber is an inward tilt of the wheel at the top.

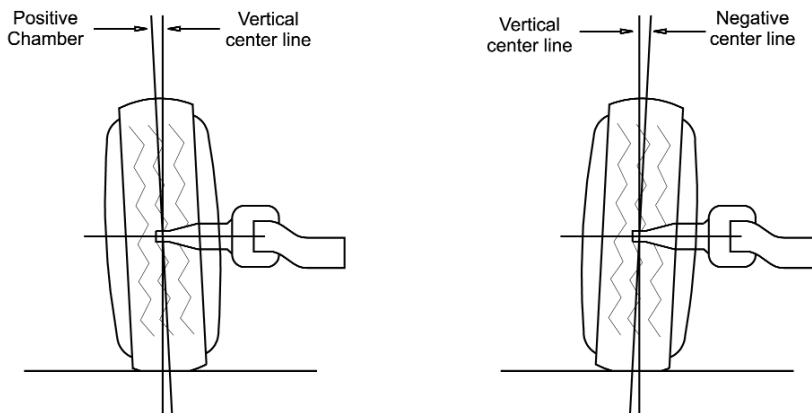

### Nominal Camber Values-Degrees

Left .20 degree tolerance .70 degree

Right .20 degree tolerance .70 degree

### Toe Setting

The toe setting represents different distances between the front and rear of the tires (measured at the vertical centerline of the tires).

Toe-in occurs when the tire front distance is less than the tire rear distance.

Toe-out occurs when the tire front distance is greater than the tire rear distance.

Wheels are generally set with initial toe-in. As the vehicle operates, tires tend toward a toe-out condition. By starting with an initial toe-in setting, a desirable “near zero toe-in” can be achieved when the vehicle is in motion.

Incorrect toe settings, where toed-in or toed-out, can have a significant effect on tire wear. The toe setting is adjusted by lengthening or shortening the cross tube.

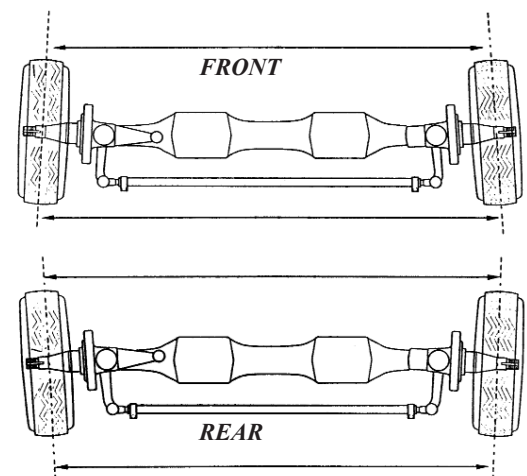

The toe setting is .03 degree.



## Caster Adjustments

Caster is the fore and aft tilt (toward the front or rear of the motorhome) of the steering kingpin as viewed from the side of the motorhome.

“Positive” caster is the tilt of the top end of the kingpin toward the rear of the motorhome.

“Negative” caster is the tilt of the top end of the kingpin toward the front of the motorhome.

A caster angle more positive than specified may result in excessive steering effort and/or shimmy. An angle less positive may result in vehicle wander or poor steering return to center. The caster angle is determined by the installed position of the steer axle.

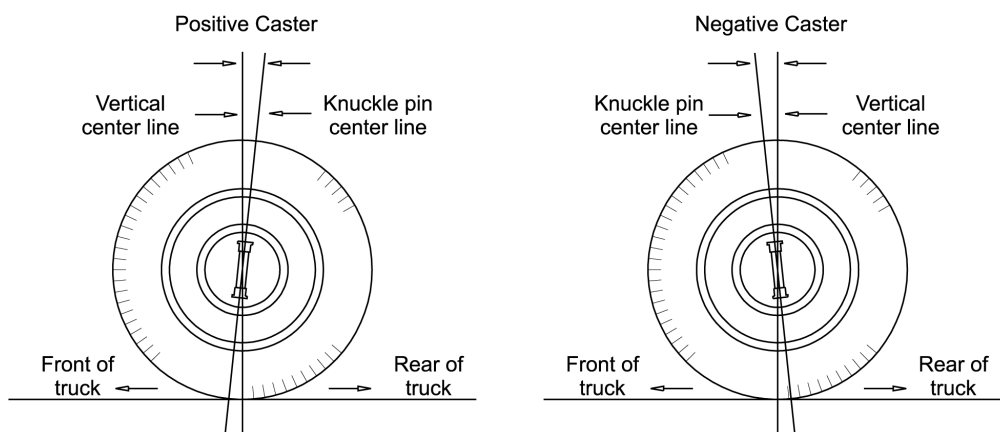

*The caster angle will be 5 degrees +/- 1.5 degree.*

## Care and Maintenance of Tires Preflight Checklist

What if you don't check your air pressure? If a tire picks up a nail or screw that creates a slow leak and causes some air pressure loss, you might eventually spot this visually if it is a front tire or an outside rear dual. However, if it is an inside dual, the chances of spotting it without an air pressure check are very slim. If you begin driving without finding it, very quickly (in most cases a few miles) your outside rear tire next to the low air pressure tire is going to heat up from carrying double its load, causing both tires to fail. Then you have two tires down on the same side and on the same axle.

As you “preflight” check your motorhome every “drive morning,” include an air pressure check of your tires. The peace of mind is worth the extra few minutes!

## Proper Cleaning

Like the rest of your RV, it pays to keep your tires clean. Road oil will cause deterioration of the rubber. Dirt buildup will help hold chemicals in the air next to the tire and will also deteriorate the tire.

As with the cleaning of any rubber product, proper care and methods in cleaning must be used to obtain the maximum service years out of your tires. A soft brush and the normal mild soap that you would use to clean your RV may be used. If you use a dressing product to “protect” your tires from aging, use extra care and caution. Tire dressings that contain petroleum products or alcohol may cause deterioration or

cracking.

In many cases, it is not the dressing itself that can be a problem, but more the chemical reaction. When these same dressing products are used on a passenger care tire that is replaced every three to four years, it is rare to see a major problem. However, in most cases, RV tires may last much longer due to limited annual mileage, and the chemical reactions have much longer to take effect.

Extreme caution must be taken to ensure that the tires are fully supported when using blocks to level motorhome. The load on the tire should be evenly distributed on the block. In the case of duals, distribute evenly on blocks for both tires. If not properly done, the steel cables in the sidewall of the tires may be damaged and could lead to premature fatigue of the sidewall.

---

***The Use of Blocks to Level Motorhomes RV's Equipped with Radial Tires***

Your RV is designed for recreation, not long-term storage. However, unless you are a “full timer,” you have no other choice. Rubber tires age faster when not being used. A cool, dry, sealed garage is your best bet for storage. However, many RVs are stored outside in the elements. Some storage surfaces may cause tires to age prematurely. For this reason, Goodyear recommends placing a barrier (i.e. cardboard, plastic or plywood) between the tire and the storage floor/ground surface.

---

***RV Tire Long Term Storage***

There are a few steps that you can take to reduce the aging effects from long-term storage or a non-use period. Thoroughly clean your tires. Cover the tires to block direct sunlight and ultraviolet rays. Store your RV out of a high ozone area. Failure to take these steps can cause early deterioration and shorten the life of your tires.



**NOTE: When the motorhome is stored, tires should be inflated to maximum inflation pressure as indicated on the sidewall of the tire.**

Before removing your motorhome from long-term storage, thoroughly inspect each of its tires. This means a close examination of each tire's tread area and air pressure. If your pressure check indicates the tires have lost air during storage, be sure to inflate them to the correct pressure for the current load before putting the unit into service.

If you have a flat tire it is recommended you call for roadside service. The size and weight of the motorhome, and the size and weight of the tire, require proper equipment to change the tire. A professional service technician will have the proper equipment and training to repair or replace your tire. In the case of sudden tire failure, avoid heavy braking. Hold the steering wheel firmly and gradually decrease speed. Slowly move to a safe off-road place, which should be a firm level spot. Turn your ignition off and turn your haz-

---

***In Case of a Flat Tire***

ard flasher system ON. Goodyear has an emergency number which offers 24 hours assistance, contact (877) 484-7376. The old tire should be saved for warranty.

For used Nuts, Add 2 Drops of Oil  
Between Flange and Hex



Lug nut tightening sequence.

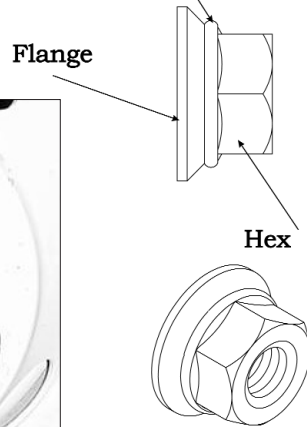

### Front Wheels

Slide the front wheel over the studs, being careful not to damage stud threads. Snug the nuts in sequence, do not tighten them fully until all have been seated. Tighten the nuts to the 500 ft.lbs sequence as shown in the illustration.

### Dual Rear Wheels

Slide the inner dual wheel over the studs, being careful not to damage the stud threads. Align the handholds for valve access and slide the outer dual wheel over the studs, again being careful not to damage the stud threads.

Snug the nuts in sequence, do not tighten them fully until all have been seated. Tighten the nuts to 500 ft. lbs. using the sequence as shown in the illustration. The hub mount wheels use two piece flange cap nuts for both front and rear applications. No inner cap nuts are required.

### Torque the Nuts Properly

- Be sure to tighten the wheel nuts to the recommended nut torque. Do not over tighten.
- Maintain the nut torque at the recommended level through planned periodic checks, or at 10,000 miles intervals, whichever comes first.
- If air wrenches are used, they must be periodically calibrated for the proper torque output. Use a torque wrench to check the air wrench output and adjust the line pressure for the correct torque.



**NOTE: Loosen lug nuts and sequence tighten in a star pattern to proper torque (500 ft lb dry). Important: sequence tighten to 50 ft lb first, then sequence tighten to 500 lb ( over tightening can cause distortion).**



**WARNING: Tires are extremely heavy. To avoid personal injury and/or property damage, obtain professional tire service help if you have a flat tire or tire blow out. Do not attempt to change the tire yourself.**

## **BRAKES**

The chassis incorporates four separate braking systems. The Primary Brake System uses a hydraulic brake actuation system. This system includes a hydraulic booster assembly, a master cylinder assembly and a monitoring system. A reserve electric hydraulic pump is included as a safety feature to provide limited power assisted stops should the primary system fails. An Antilock Braking System (ABS). The Parking/Emergency Brake System. The Engine Braking System is the Jacobs Brake System.

The Hydro-Max brake system gets primary power for the booster from the power steering pump. The reserve electric motor pump is turned on by a relay which is activated when an integral flow switch detects the lost flow of power steering fluid. The brakes will remain operational with a greatly increased stopping distance in the event both primary hydraulic and back up electrical pump fail to operate.

The Hydraulic Antilock Braking System is an electronic wheel speed monitoring and control system. The Electronic Control Unit (ECU) receives and processes signals sent from the wheel sensors located on each of the wheels. The ECU will process the signals and generate the commands to the solenoid control valves housed in the Modulator Assemble used to control the brake pressure. This process commences when the wheels begin to lock. The rapid valve operations may even be noticed in the brake pedal.

## **BRAKING SYSTEM (ABS)**

The ABS indicator light located on the dash will alert the driver to possible system faults and is used by service personnel to assist in troubleshooting. In the event the ABS indicator light remains illuminated, the motorhome brake system will not be affected. However, continue to drive at a reduced rate of speed to the nearest repair facility.

The parking brake system is activated when the push-pull control knob (located on the drivers left console panel) is pulled. When the knob is pushed, the brake is released. Prior to driving, allow time for the air compressor to build up sufficient air to shut off the air warning lamp.

## **BRAKE (PARKING)**

## AUXILIARY BRAKE SYSTEM (Exhaust Brake)

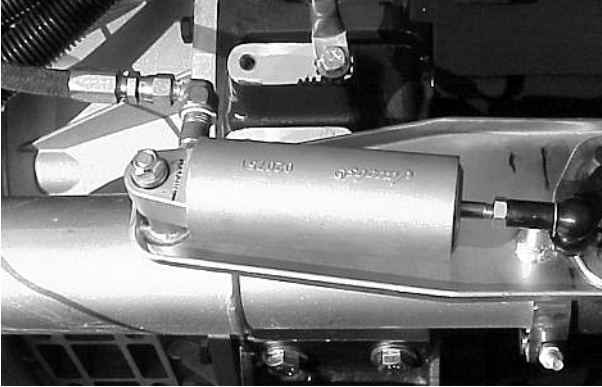

Exhaust Brake.

The Jacobs (Jake) brake, located in the exhaust system of the ISB engine, is designed to supplement the primary hydraulic braking system. Various features and benefits are obtained with this application. Attached directly to the engine turbocharger, the Jake brake is activated when the dash switch at the drivers console is switched “ON” and the throttle is “RELEASED”. The Jake brake will not disengage the cruise control. This must be accomplished by tapping the service brake pedal. The amount of braking power developed, which is applied to the drive wheels only, is relevant to the engine speed (RPM). A butterfly plate inside the brake moves to restrict the flow of exhaust gases, causing an increase of

backpressure in the engine. The increase of backpressure slows down the engine and creates an increased control in the coach braking performance. This slowing power will reduce the need to use your service brake and result in a service brake savings. This is not a substitute for your service brake and cannot stop the coach completely. The Jake brake can be used continuously on steep downhill grades, or long freeway off ramp. Use of the engine braking system allows the engine temperature to drop while going downhill. The Jake brake should be turned off prior to starting the engine, and when the engine is left idling for long periods of time.



**CAUTION: Use of the Jake brake on wet and slippery surfaces can result in overbraking and loss of traction.**

When the Jake brake is activated, the sound of the engine may vary. You may or may not feel the retarding effect. Once deactivated, normal throttle response with a slight change in RPM should occur.

## MAINTENANCE & TROUBLESHOOTING BRAKES

The most critical part of the service brake system is bleeding the system. Prior to bleeding the system, ensure all hose clamps, line connector and fittings are tight enough to prevent air from entering the system or fluid from leaking. The hydraulic brake system must be free of air to function properly. When bleeding, check the fluid level in both the power steering reservoir and master cylinder.



**NOTE: The power steering system and Hydro-max system are two separate hydraulic systems. The fluids are not compatible and should not be mixed. Mixing of fluids will damage the systems and reduce service life.**



**NOTE: Do not attempt to move the motorhome in the event any line is disconnected, component removed or part of the hydraulic brake system is opened. There will be no braking capabilities until the affected system is bled.**

If power steering fluid is noticed in the master cylinder, End Cap service on the power booster assembly can correct the leak.

The Hydro-Max system should be bled prior to the brake system. Applying the brakes will cycle the pump and purge any air from the electric pump system. The engine will need to be started to bleed the booster. When started, applying the brakes 2 to 3 times will purge the air from the booster. Inspect fluid levels, add fluid as required.



**WARNING: Brake lining may contain asbestos material and should only be serviced by qualified service technicians who are trained in the appropriate precautionary procedures.**

The electric pump motor is reserve power for the booster assembly. The entire assembly should be replaced when a failure occurs. When the electric pump motor is working you will only have 1/2 the brake boost. Caution should be taken as braking distance will be increased. The reserve power test is a quick test to ensure that the electric pump motor is operational. You would simply apply the brake pedal with the ignition “OFF.” The electric pump should run and be audible.

The design of the master cylinder provides two separate brake fluid systems (front and rear). One system will operate should a failure occur in the other. When checking the fluid level in the master cylinder, the fluid should be clean with no evidence of contamination. You should observe a surge of fluid with the brake pedal applied, and fluid level be at the bottom of the port ring openings. Since the master cylinder is the highest point of the system, gravity flow bleeding can be accomplished. Gravity flow bleeding requires one person and NO pressure bleeder. Each caliper has a bleeder valve for removing any air in the system.

It is important a supply of clean brake fluid be used during bleeding. Also, maintain the proper fluid level in the reservoir during bleeding. The sequence for opening the bleeder valves is curbside rear, roadside rear, curbside front and roadside front. A clear plastic tube inserted over the bleeder valve can aide in viewing air. Place the other end of the plastic tube in a container to catch the drain. When the valve is opened, observe the flow of fluid. Once a steady flow of fluid is present, close the bleeder valve. Check the fluid level in the master cylinder and repeat the process for the remaining calipers.

## ELECTRIC PUMP & MASTER CYLINDER

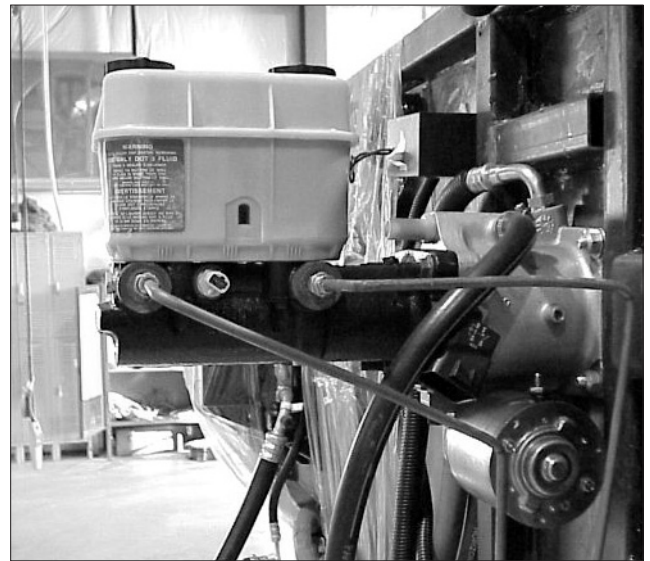

*Hydramax rightside view.*

## ***Bleeding the System***

Flushing the system requires that the bleeder valve be left open until the fluid appears clear and uncontaminated. The system should be flushed whenever any repair has been performed, ensuring clean and uncontaminated fluid in the system.



**NOTE: Do not reuse brake fluid which has been drained as the fluid may be contaminated.**

Tires, suspension, wheel alignment and shocks can affect braking performance and should be inspected prior to checking the braking system. Some problems and repairs are listed below:

- Pedal fade is a good indication of leaks in the system. Inspect and repair leaks.
- Sluggish brake response indicates air has been introduced into the system. Bleed the brake system.
- Excessive pedal travel or excessive pedal effort relates to booster and master cylinder.
- Booster doesn't function properly in power or back up mode. Repair the booster and pump assembly.
- Booster works only in the back up mode. Repair the booster assembly.
- Booster works only in the power mode. Repair the back up pump.
- Dragging, grabbing, squealing or pulling brakes require servicing pads and calipers.

---

### **Auxillary Brake System (Exhaust Brake)**

The Jacobs brake system, used routinely at normal exhaust operating temperatures, is virtually maintenance free. Some contributing causes which can result in failures with the Jake brake include moisture, dirt, carbon and improper usage.

Starting the engine and idling for short periods of time is not recommended. Moisture is created within the engine and the exhaust system during cold startups. When normal operating temperatures are not obtained, moisture may get trapped in the valve housing resulting in rust, leading to insufficient operation of the Jake brake.

Some problems you may encounter with your Jake brake include, but are not limited to, will not activate or deactivate, intermittent on/off operations or actuates with the switch off. These are commonly related to electrical symptoms. Slow operations or delays in operations, as well as limited performance, are mechanical symptoms. You should refer these problems to your dealer for diagnosis.

## HYDRAULIC LEVELING SYSTEM

The three point leveling system features a multiple warning system with flashing light and a bong alarm to alert you of the jack position. The system also features a remote control location from the driver seat. The torsion stress is significantly reduced during proper operating procedures. Damage resulting from improper procedures can range from windshield damage to entry doors jamming.

The model 22.5A J-II leveling system pump is located curbside front with easy access from the generator door. The valve assembly manifold is mounted on the the pump motor, providing easy access to the manual retract valves. The system is designed to be self bleeding in the event any component of the hydraulics has been removed or repaired. Fully extend and retract each jack twice. The remote rocker switches will operate with a minimum of 7.5 VDC. Optimum requirements for operating the system are voltages above 9.6 VDC.

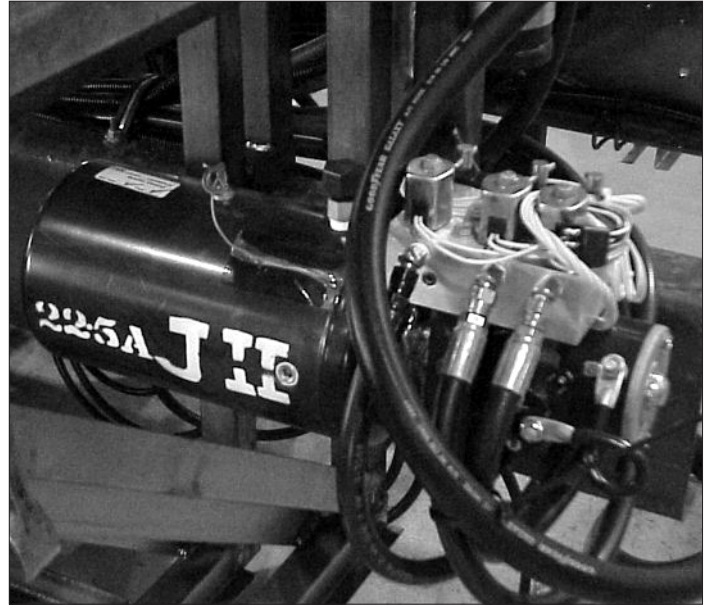

*Hydraulic Reservoir.*



**NOTE: The leveling system jacks are not designed for use in changing tires. This can cause problems with the suspension system, frame alignment and damage to the windshields.**

When manually operating the leveling system, always lower the front jack first. The front jack acts as a pivot point for chassis and reduces torsion stress on the body of the motorhome.



**NOTE: In the event the front of the motorhome is high and does not require elevating, it will be necessary to raise front of motorhome a minimum of 1/2 inch to allow jacks to act as a pivot point.**

The leveling system was designed to reduce site selection problems. If possible, park the motorhome with the front facing downhill. If the ground is soft, place a wooden 2 X 8 board under the foot of each jack pad to prevent sinking.

### **Manual Leveling System**



The front jack will be the pivot point for the chassis and is always lowered first. This reduces the torsion stress on the body of the motorhome. The Bong alarm will activate when any jack is extended more than 2" to 6" from fully retracted position and will indicate low fluid level for the pump motor. The Bong alarm may momentarily activate when driving over rough roads, or negotiating curves and corners. Usually this indicates low fluid level.



**NOTE: Air will not automatically dump from air bags when leveling cycle begins. To expedite the air dumping, a manual air bag release switch is located on the dash panel.**

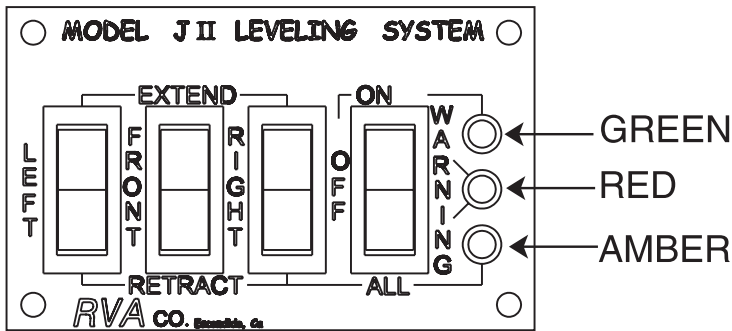

- Place the gear selector in PARK.
- Apply the parking brake.
- Turn the ignition switch to the ON position.
- Switch the main jack control power switch ON.
- To extend a particular jack, push the appropriate rocker switch to extend position and hold it until the desired extension is reached.
- To retract a particular jack, simply push the rocker switch to the retract position and hold until the desired retraction is reached.
- Turn off the switch labeled POWER on the jack control panel.
- Turn off the ignition switch.

### Retracting the System

- Ensure the gear selector is in PARK.
- Ensure the parking brake is applied.
- Turn the ignition switch to the ON position.
- For manual control of the system, switch the control panel power switch ON.
- To retract a particular jack, simply push the rocker switch to the retract.
- All jacks may be retracted by selecting the ALL position on the power switch.



**NOTE: Do not move the motorhome until the jacks are fully retracted. A visual check of the jacks is recommended to ensure full retraction. Do not rely solely on the lights and alarms.**

## Manual Retract Valves

In the event of mechanical or electrical failure that would prevent the leveling jacks from being automatically retracted, the motorhome is equipped with manual emergency retract valves. These valves are located inside the front generator access.

This manual system will release fluid under pressure in each jack and allow fluid to return to the reservoir. The jacks will then retract.

To operate the manual system, turn all three valves counterclockwise until they stop.

Once the jacks are fully retracted, rotate all the valves fully clockwise. In the event one of the jacks is not holding pressure, check the position of the retract valve.

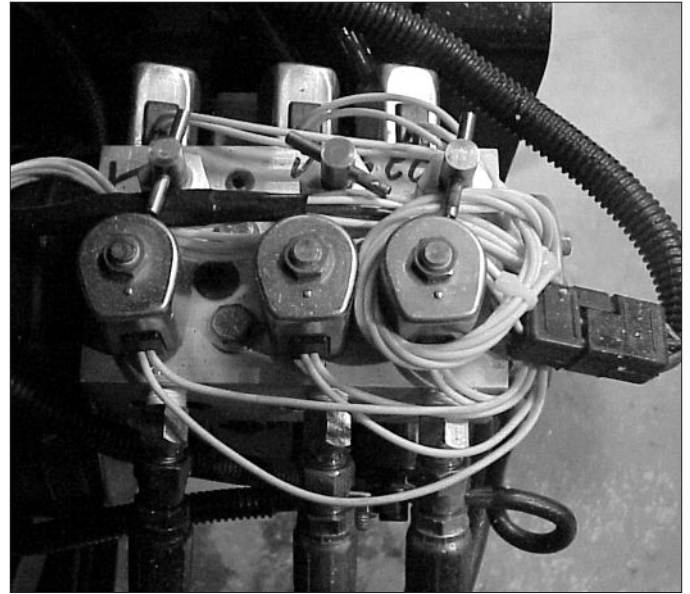

Manual Release Valves.

## Maintenance

Occasionally, while the jacks are fully extended, wipe dirt from the jack rod. This will help lengthen the life of the jacks. This can vary from the amount and type of usage of the jacks. Dexron III will serve as a solvent as well as a lubricant. Occasional oil or grease on the extended jack ram is normal and aids in the lubrication of the ram. It helps to learn the sound of the normal pumping and gurgling sounds of the pump when it is low on fluid.

### Adding Fluid:

1. Use Dexron III automatic transmission fluid.
2. Extend any jack 6 inches from the full retracted position. All other jacks should be fully retracted.
3. Unscrew the reservoir cap from the top of the pump.
4. Turn the ignition switch to the ON position. Turn the rocker switch to ON. Open the window so the bong alarm is audible from outside the motorhome. Slowly fill the reservoir with fluid until the bong alarm stops sounding.
5. Replace the reservoir cap.
6. Turn the ignition switch and the remote panel OFF.

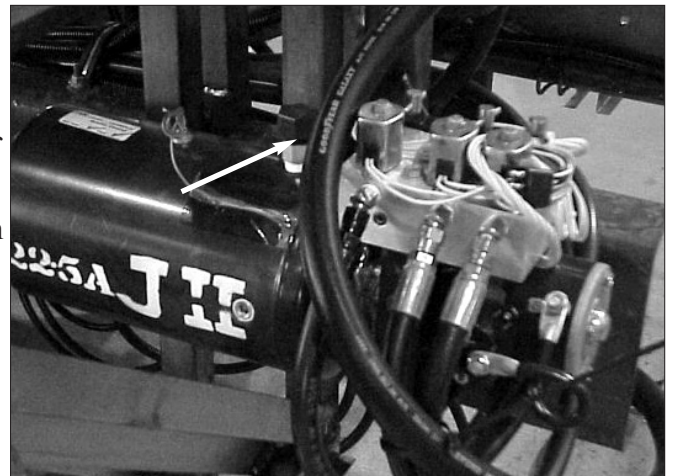

Fill Cap.

## SLIDE-OUT ROOM

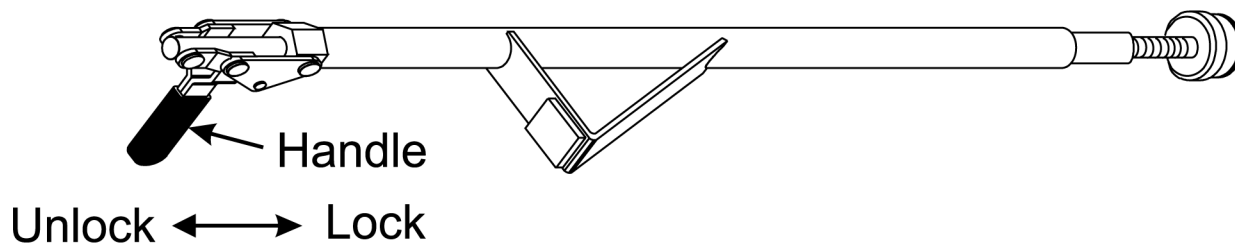

---

### **Extending the Slide-out Room**

Locate the two locking bars on the top of the slide-out room inside the motorhome. Move the handles to the unlock position. Release the bar mechanisms and remove the bars from the top of the slide-out room and the wall. Store the bars for use prior to moving the motorhome.

- Ensure the ignition key is in the OFF position.
- The park brake is applied.
- The storage bay doors under the slide-out room must be closed.
- The driver seat has been moved forward before activating the slide-out room.
- Access the slide-out room control switch located in the side overhead compartment above the entry door.
- Press and hold the slide-out room switch in the OUT position. The slide-out room will slowly move to the OUT position. The slide-out drive motor will not stop automatically.
- Release the slide-out room control switch once the slide-out room has been extended to the desired position.
- Level the motorhome on the three point leveling system.



**NOTE: It is not recommended to extend the slide room in snow, sleet, ice or freezing rain. There may be extensive damage resulting from awning freeze up.**

**NOTE: Slide-out room operation should be performed with a full air suspension system.**

**NOTE: Monaco Coach Corporation is not responsible for LOCK'R bars left in position during slide operations. Damage can result if they are left in position.**

---

### **Retracting the Slide-out Room**

- Ensure no obstacles are in the path of the slide-out room inside the motorhome.
- Ensure the slide-out room awning has been retracted.
- Ensure the ignition key is in the OFF position.
- The park brake is applied.
- The storage bay doors under the slide-out room must be closed.
- The driver seat has been moved forward before activating the slide-out room.
- Access the slide-out room control switch located in the side overhead compartment above the entry door.

- Press and hold the slide-out room switch in the IN position. The slide-out room will slowly move to the IN position. The slide-out drive motor will not stop automatically.
- Release the slide-out room control switch once the slide-out room been retracted to the desired position.



**CAUTION:** Ensure there is 5 or more feet of clear space outside the slide box prior to extending the slide room. The outside area must be clear of any obstructions which may hinder the movement of the slide room. Ensure there is sufficient clearance inside the motorhome. Dirt and grit trapped under the slide could result in damage to the floor. Continuous operation of the slide-out could cause a drain on the house batteries and damage to the the slide motor from overheating. Never move the motorhome with the slide-out extended.

The slide-out room can be operated manually in the event of electrical problems. The slide-out room motor and gear assembly is located roadside, in the large pass-through storage compartment.

The lever on the motor must be moved to the freewheel position.

The drive shaft can be moved using a 7/8 inch wrench.

Once the slide-out room has been placed in the desired position, place the motor lever in the service position.

### Troubleshooting

The following can be used as a guide to assist you in the event of a slide room malfunction.

#### The slide room will not move.

- The house batteries should be fully charged prior to operating the slide out.
- The ignition switch should be in the OFF position.
- The fuse for the slide-out room is located in the bedroom panel. This is a 15 amp fuse.
- The fuse for ignition lock-out is located in the front run panel. This is a 7.5 amp fuse.
- The slide-out room motor input voltage requirements are 12 VAC.

#### The slide room movement is jerky.

- The rollers will need adjustment.
- The gear is worn or damaged.
- The slide room is binding in the opening.
- The wipe seal is rubbing the slide room too hard.
- The voltage is low.

### Manual Operations

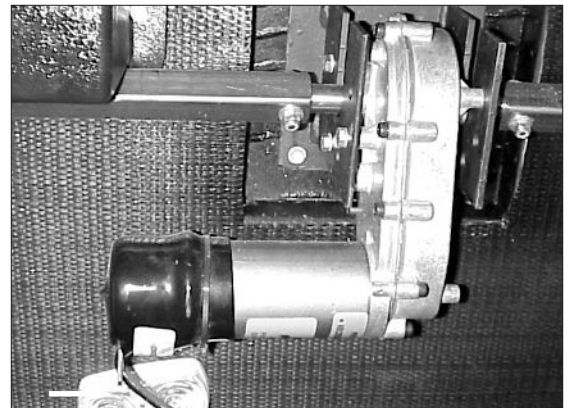

Location of slide motor lever.

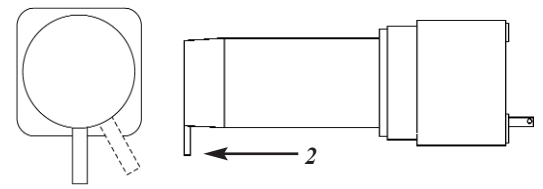

1. Rotate approx. 30 counterclockwise to release the motor brake.

2. Brake lever.

**Front of Coach**

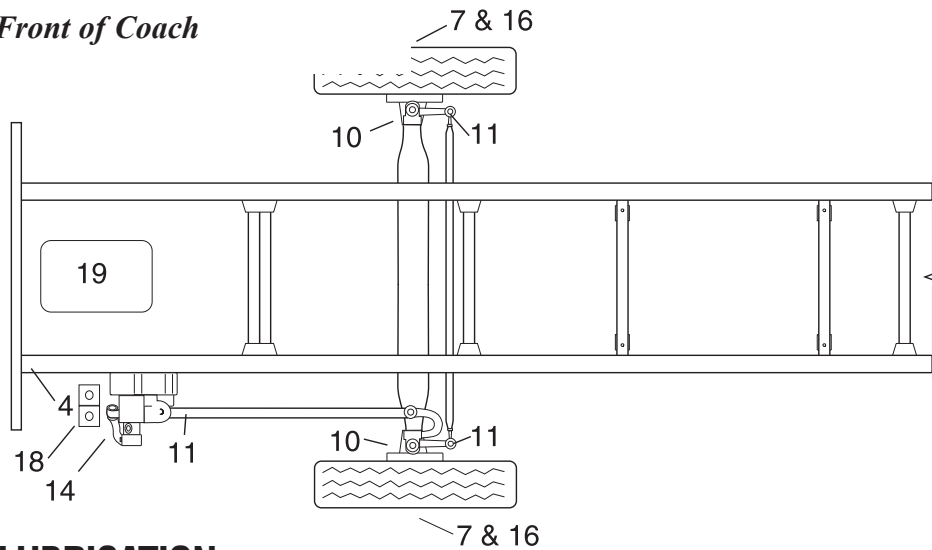

**LUBRICATION**

Service must be performed every twelve (12) months regardless of actual mileage, to protect seals, bearings and gaskets from drying out and failing. The motorhome must be started and driven for at least 20 miles bimonthly.

Component	Action	When	Code - Refer To Chart
1. Engine Oil	Keep To Full Mark	Check Daily	EO
2. Engine Oil Filter	Replace	At Oil Change	OP
3. Transmission	Keep To Full Mark	Refer O&E Manual	TF
4. Steering Shaft	3 Fittings	30,000 or Annually	CL-4
5. Drive Shaft U-Joints	2 Fittings	10,000 or Annually	CL
6. Drive Shaft Slip Joint	1 Fitting	10,000 or Annually	CL
7. Steering Axle Hubs	Check Oil level line	1,000	GO
8. Battery Terminals	Apply Coating	10,000 or Annually	P
9. Rear Axle Differential		50,000 or 3 Years	MP
10. King Pins & Knuckles	2 Fitting Each End	5,000 or 6 months	CL
11. Drag Link/Tie Rod	4 Fittings	5,000 or 6 months	CL
12. Power Steering Reservoir	Keep To Full	6,000 or 3 months	AW
13. Power Steering Filter	Replace	15,000 or Annually	AW
14. Steering Gear Box	1 Fitting	30,000 or Annually	CL
15. Engine Coolant	Replace	Every 2 Years	AF
16. Steering Axle Hubs	Change	30,000 or Annually	GO
17. Engine Fuel Filter	Change	15,000 or 6 months	FF
18. Master Cylinder	Keep to Full	6 months	BF
19. Generator Set	Hours	Refer O&E manual	OP
20. RVA Reservoir	Fill	as required	TF

It is important to remember the generator lubrication interval is based on hours of usage. Consult the O & E manual for your genset service interval.

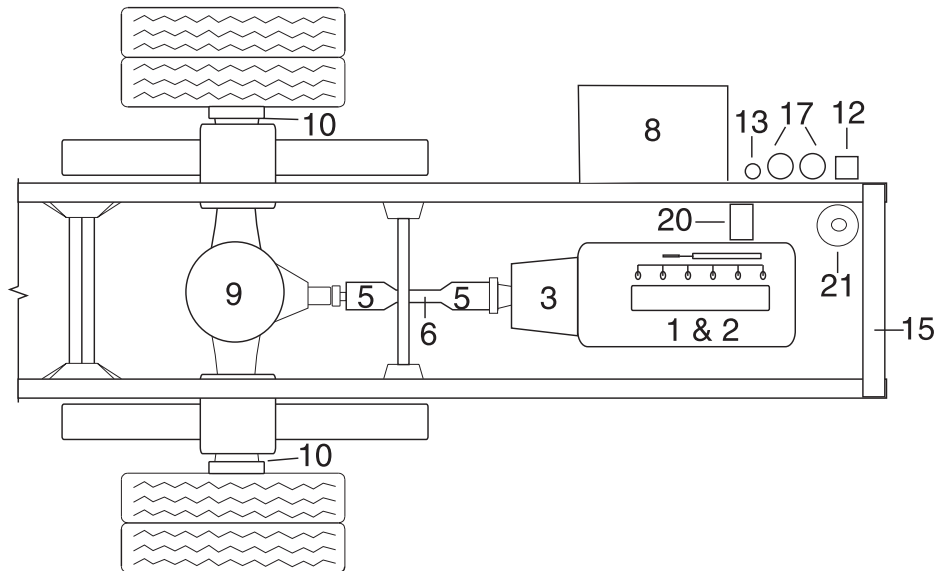
**Rear of Coach****Lubrication Code Chart**

- CL-4 U-Joints located inside coach under steering cover.
- EO Engine oil as recommended by engine manufacturer.
- OP Refer to operators manual.
- MP API GL-5 or MT-1 type gear lubricant - Pennzoil Gear Plus SUPER-EW 75W-90, Synthetic.
- GO EP-SAE 90 gear oil.
- CL Chassis lubricant should be a high quality non corrosive multipurpose lithium soap pressure gun lubricant that is water resistant and designed to withstand extremely high operating temperatures.
- TF Transmission fluid. Use DEXRON 3 transmission fluid only.
- P Petroleum jelly, or a commercial battery terminal corrosion inhibitor.
- AW Pennzoil AW-46 Hydraulic fluid.
- AF Consult Cummins Owners manual for antifreeze type.
- BF Dot-3 Brake fluid .
- FF Fuel Filter.

## Checking the Oil Bath Hubs (Steering Axle Only)

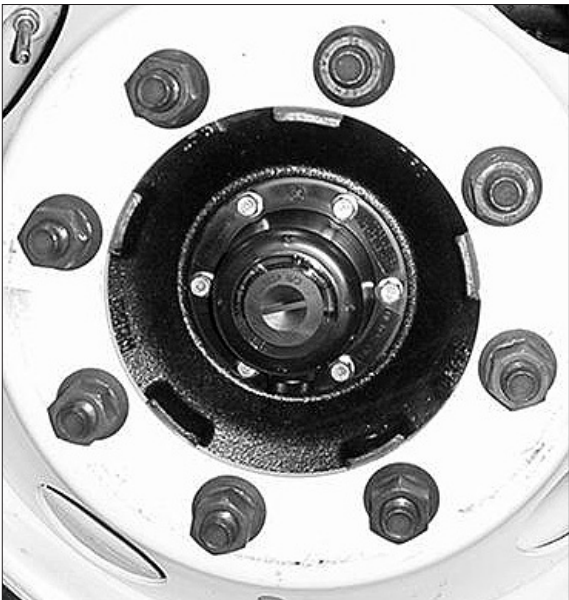

Oil Hub.

All front axles supplied by Westport Axle corporation incorporate oil bath hubs. The chrome simulation wheel cover will need to be removed before the inspection can take place. You will be able to see the oil level through the clear plastic sight ring. The ring is clearly marked “minimum oil level.” The oil level should be inside the arrows. Adding lubrication oil to the hub is a simple process. You need only remove the black rubber plug. Ensure dust and dirt does not enter the hub, and add the proper amount of oil. Wait a few minutes to allow the oil to flow through the bearings and recheck the level. Use only a SAE 90 gear oil. Synthetic lubricants may be use. **DO NOT MIX PETROLEUM BASED WITH SYNTHETIC BASED OILS, AS OIL SEAL FAILURE MAY RESULT.** Once you have the proper oil level reseal the black rubber plug. You should visually inspect the oil level before every trip and at every 1,000 miles. You should notice the oil is not frothy, foamy or milky. These appearances indicate the need to change and repair possible problems in the axle.

## Lube Interval

The frequency of lubricant change depends upon the individual operating conditions, speeds and loads. Change at 30,000 miles or annually. The chrome simulation wheel cover will need to be removed before the change can take place. You will need a container to catch the old oil for proper disposal. Place the container under the hub and open the small black drain plug allowing the oil to flow out. When drained, reinstall the drain plug and follow the process for adding lubrication oil.

Your axle has come to you with SAE 90 gear oil. The recommended oil change interval is based on the operating conditions, speeds and loads. Limited service applications may allow the recommended change interval to be extended. Severe applications may require the recommended change and check interval to be performed more frequently. More information can be obtained by contacting a Westport service representative.

**DRIVELINE****Greasing the Driveline Universal Joint**

1. Check the driveline for looseness. If loose, service the driveline as necessary.
2. Apply the specified grease at the grease fitting on the universal joint. Apply grease until the new grease purges from all the seals.
3. If the new grease does not purge at the seals, loosen the bearing cap bolts and regrease until all four caps purge. If the new grease still does not purge, replace the universal joint.

**Greasing the Driveline Slip Yoke and Spline**

1. Check the driveline for looseness. If loose, service the driveline as necessary.
2. Cover the air hole so that grease can flow easily to the seal. Apply the specified grease at the grease fitting on the slip yoke. Apply grease until new grease purges from the air hole in the end of the slip yoke.

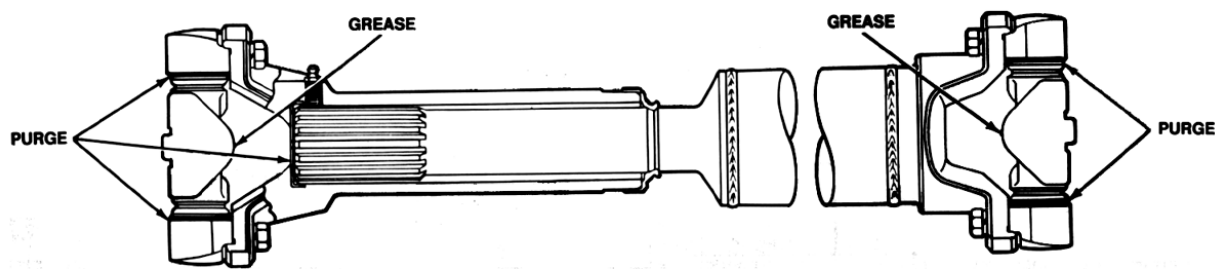
**Greasing Intervals-10,000 miles or annual***Driveline.***STEERING GEAR BOX GREASE FITTING**

Maintain the grease pack behind the output shaft dirt and water seal as a general maintenance procedure at least twice a year. The grease fitting is provided in the housing trunnion. Use NLGI grade 2 or 3 multipurpose chassis lube and use only a hand operated grease gun on the fitting. Add grease until it begins to extrude past the sector shaft dirt and water seal.

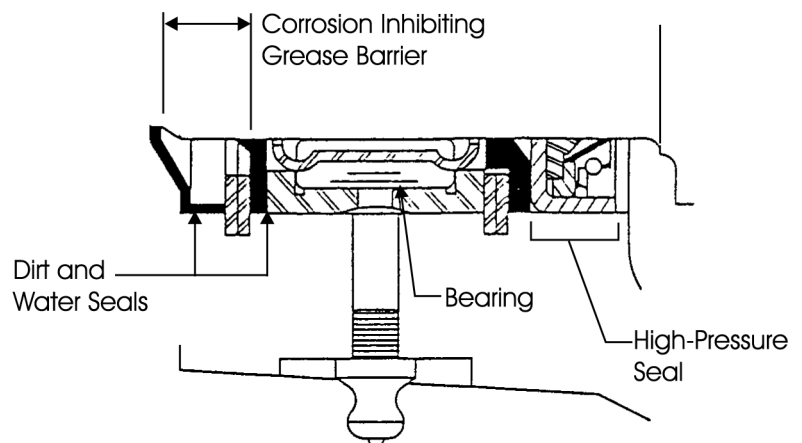



## DRIVE AXLE LUBRICANT

### Proper Drive Axle Lubricant Level

- Regular inspection of the drive axle lube levels is an essential maintenance procedure.
- The lubricant should be level with bottom of the hole.
- Important: The lube level close enough to the hole to be seen or touched is not sufficient; the lube must be level with the hole.
- Your differential requires an API GL-5 or MT-1 type gear lubricant. Your differential is filled with approximately 18 quarts of Pennzoil Gear Plus Super-EW 75W-90 synthetic.



**NOTE:** When checking the lube level, also check the housing breather. Clean the breather if dirty, or replace them if damaged.

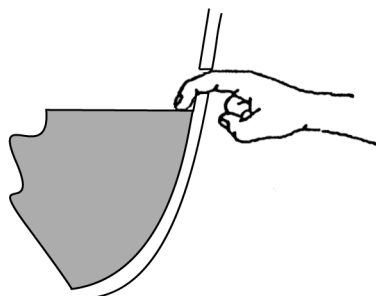

*Incorrect oil level.*

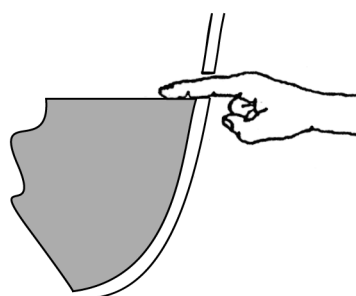

*Correct oil level.*

## FILTERS & BELTS

FILTERS AND BELTS	MANUFACTURER	NUMBER
Oil Filter	Fleetguard	LF 3729
Fuel Filter Primary	Raycor	S3201T
Fuel Filter Secondary	Fleetguard	FS 10519
Transmission Filter Remote Spin On	Filtech	29531007
Power Steering Filter	Nelson	84365 cellulose (one year)
	Nelson	87904 synthetic (five year)
Alternator Belt	Dayco	3911584
A/C Belt	Dayco	17435
Air Filter	Donaldson	P-537454

**TRANSMISSION  
OIL**

Any fluid meeting DEXRON-III specifications are acceptable for use in the transmission. Transmission performance, reliability, and durability are important influences in the type of fluids used. Change the fluid and remote spin on filter after the first 8000km (5000 miles). The dipstick/oil fill is located between the engine and transmission underneath the engine access door in the bedroom. Change the transmission fluid and remote spin on filter every 50,000 miles or 24 months, whichever occurs first.

The fluid and remote spin on filter may require changing sooner depending on the severity of operating conditions. The fluid must also be changed whenever there is evidence of dirt or high temperature conditions as indicated by discoloration, strong odor or fluid analysis. Local conditions, severity of operation or duty cycle will dictate more or less frequent service intervals.



**For more detailed information consult the Allison Transmission Owner's Manual.**

The concept of a cold check is to determine adequate fluid level for safe operating until hot check can be performed.

***Cold Check***

- Park the motorhome on a level surface using the service brakes.
- The engine is operated at a low idle, put the transmission in P (Park)
- Apply the parking brake and chock the wheels to prevent the motorhome from moving.
- Allow the engine to run at idle (500-800 rpm) for one minute.
- Apply the service brakes and shift to D (Drive), then to N (Neutral) and then to R (Reverse) to fill the system. Finally shift to P (Park) and release the service brakes. Allow the engine to continue to run at idle (500-800 rpm).
- Remove the dipstick and wipe clean. Reinsert the dipstick fully into the tube and remove to check fluid level. Repeat this to verify the reading if needed.
- Safe operating level is anywhere within the COLD CHECK band on the dipstick. The fluid level is sufficient enough to operate until a HOT CHECK can be run.
- If the level is not within this band, add or drain the fluid as necessary to bring the level to the middle of the COLD CHECK band.
- Perform the HOT CHECK the first opportunity after reaching normal operating temperatures (160°-200°F/71°-93°C).

## Hot Check

- Because the fluid level rises as the temperature increases, the fluid must be hot to ensure an accurate check.
- Be sure the fluid has reached normal operating temperature (160°-200°F/71°-93°C). If a transmission temperature gauge is not present, check the fluid level when the engine water temperature gauge has stabilized and the transmission has been operated under a load for at least one hour.
- Park the motorhome on a level surface and shift to P (Park). Apply the parking brake and allow the engine to idle (500-800 rpm).
- After wiping the dipstick clean, check the fluid level. Safe operating level is anywhere within the HOT RUN band on the dipstick.
- The width of the HOT RUN band is approximately 1 quart of fluid at normal temperature range.
- If the level is not within this band, add or drain the fluid as necessary to bring the level within the HOT RUN band.
- Be sure that the fluid level checks are consistent. Check the level more than once. If the readings are not consistent ensure that the transmission breather is clean and not clogged. If the readings are still not consistent, contact your nearest Allison distributor or dealer.

---

## POWER STEERING RESERVOIR

As you perform walk around and pre-checks, look for oil leaks under the coach and/or at hose fittings. If oil seepage appears at a hose connection, have the oil cleaned as soon as possible as this may be an early warning sign of potential trouble.

The power steering reservoir is located curbside in the engine access area under the bed. The reservoir is filled with AW-46 Pennzoil Hydraulic Fluid from the factory.

Check the oil level in the reservoir every 6000 miles or three months. The oil dipstick fill is located on top of the reservoir in the rear compartment. The oil level should be kept between the full and add marks on the dipstick. Change the hydraulic oil filter every 15,000 miles, or once a year for cellulose element. A synthetic media filter is available which will extend the interval to once every five years.

## Engine Maintenance Checks & Coolant Fluid Fill

The engine maintenance checks and fills can be accessed through the rear access doors. The doors swing open allowing access to compartment. When fully opened, the doors will lock in place. To release, the small metal button must be pressed when closing the door.



**NOTE: Engine oil may also be added from the bed access compartment inside the motorhome.**

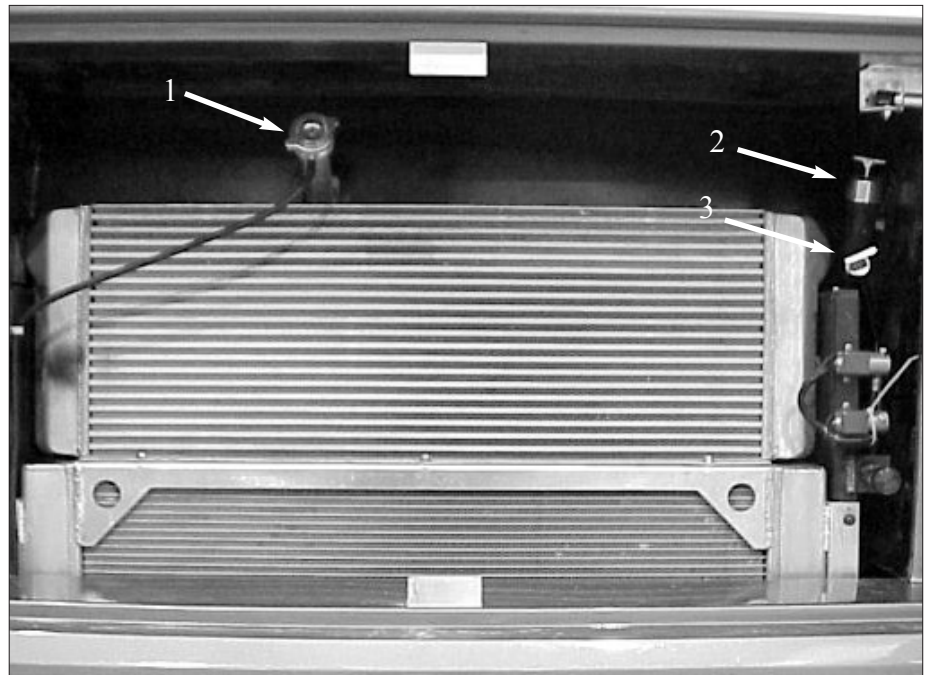

1. Coolant fill/check.
2. Oil fill.
3. Oil check.

## Transmission Maintenance Checks and Fluid Fill

The transmission maintenance checks and fill is accessed through the rear engine access doors located under the bed deck. The doors swing upward and must be latched in place with the metal hanger allowing access to engine and transmission area. The transmission dipstick is located curbside forward of the engine area. A funnel is required when adding fluid.



1. Location of transmission dipstick.
2. Transmission Electronic Control Unit.

## FUEL/WATER SEPARATOR

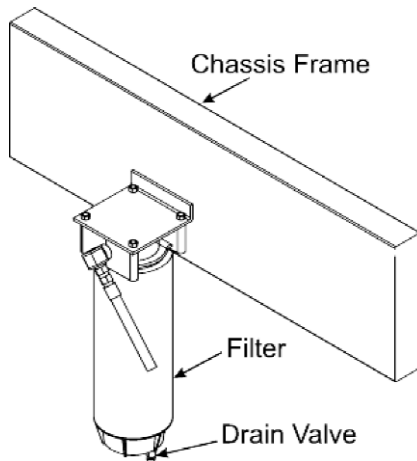

Fuel/Water Separator.

The fuel/water separator is located in the rear engine compartment and right of the frame curbside. If for any reason the WATER IN FUEL light on the dash console illuminates, the fuel filter will need to be drained. Shut the engine off and open the drain valve. Open the valve counterclockwise approximately 1 1/2 to 2 turns until the fuel starts to flow from the filter. Allow the flow to continue until water and sediment are no longer visible. Turn the valve clockwise to close the drain valve. Start the engine and verify the WATER IN FUEL light extinguishes. This procedure may have to be performed several times as water may be in the fuel lines.

---

## ALTERNATOR

The alternator is designed to convert mechanical energy produced from the engine, and convert the mechanical energy into an electrical energy. The electrical energy is first internally generated in the form of an AC voltage. The AC voltage is then passed through a diode bridge to rectify the voltage to a DC voltage level. The DC voltage level is used to maintain a proper level of voltage for operating the motorhome. The alternator is designed to operate at 12 VDC with a maximum output of 160 amps.

### Features:

- Enclosed brushes.
- Directional fan design.
- Lightweight compact construction.
- Simple two wire connection(B+ and B-).
- One terminal for Tachometer(AC).
- One terminal for Dash warning lamp(L).

### **Checkout Procedure for the Alternator.**

- The output of the alternator range is 13.5 to 14.2 VDC. Connect a voltmeter to the (B+) terminal of the alternator and chassis ground. Idle the engine up to 1200 rpm.
- Check all wiring for burnt or loose connections. Repair as needed.
- Check all grounds and connections to ensure they are clean and tight.
- Inspect the alternator for damage. A broken fan blade can damage an alternator or make it out of balance.
- Check belt, pulley and fan for wear. Replace as needed.
- Never attempt to disconnect the battery or battery wire from the alternator with the engine running. This can cause damage to the alternator or the regulator.
- The pulley for the alternator should be torqued to 80 foot pounds.

Remember the alternator is not a battery charger. It is designed to maintain the proper operating voltage level for the motorhome. A battery with a low charge or a dead battery may cause damage to the alternator.

The Centroid fuel sender has no moving parts. It works by measuring capacitance, an electrical property, between its inner and outer tubes in the tank. The more fuel between the tubes, the higher the reading. Electronics in the hockey-puck head of the sender convert the capacitance to current to drive the fuel gauge.

### **FUEL SENDING UNIT**

#### **Connections**

The Centroid sender has 4 connections:

- **POSITIVE and NEGATIVE:** battery voltage to run the electronics in the sender head.
- **SEND:** connects to the Send terminal of the gauge on the dash.
- **ALARM:** makes a connection internally to the Negative terminal when the low alarm fuel level is reached (when gauge is reading about 1/8 tank). This turns on the alarm light on the dash. It is not adjustable.

## Adjustments



Fuel Sending Unit.

The Centroid sender has 2 adjustments:

**EMPTY:** Adjusts for length of sender. It has been set at the factory and covered with a sealant. It should not be changed.

**FULL ADJUSTMENT:** The full adjustment can be used to correct for slight differences between fuel meters. During installation, it has been calibrated for your meter and should not need readjustment.

The correct adjustment technique, with a full tank of fuel, is to start with the full adjustment screw completely clockwise. This should cause the reading to be above full. Adjust slowly, counterclockwise, until the full mark is reached.

The intent is to always adjust downscale rather than upscale.

## Troubleshooting

A. Electronic output. The sender has a transistorized output. This prevents an ohmmeter from getting a correct reading of its output resistance.

B. Fuel Only: The sender will not work correctly in conducting fluids such as water ( it will read above full all the time in water). One possibility when you have a constant above-full reading is that you have water at the bottom of the fuel tank.

C. Contact Centroid: Probably 90% of the returns Centroid tests work ok on the bench. If you have incorrect readings, contact Centroid ( tel 800-423-3574, or (preferable) fax 904-423-3709) with your symptoms. You will be provided with a short "fill in the blanks" troubleshooting test appropriate to your sender. It is easier to find the problem that way than after the sender has been removed from the system, since the problem is not necessarily with the sender.

## STEPWELL COVER

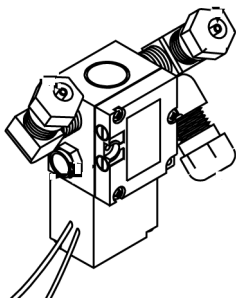

Mac Solenoid Valve.

### Step Slide Air Valve

- Used for the step slide.
- Controls air flow to the step slide.
- Two adjustment screws for air flow, one for in and one for out.
- Location - Open the generator compartment, the valve is located on the firewall.

### Adjustment

- Clockwise adjustment on the screw will decrease air flow.
- Counterclockwise adjustment on the screw will increase the air flow.

## AIR FILTER MINDER

The air filter minder is a precision airflow restriction gauge designed to take the guesswork out of air cleaner replacement. The air filter minder is located in the engine rear compartment. Its operation is simple and virtually fool proof. As dirt captured by filter cartridge slowly builds up, the system pressure drop increases and is indicated by the filter minder on an easy to read scale. The indicator locks up at the point of maximum restriction so readings can be taken with or without the engine running. When the desired change-out point is reached, the air filter should be replaced, and the service indicator is easily reset by pushing the button at the bottom of the minder.

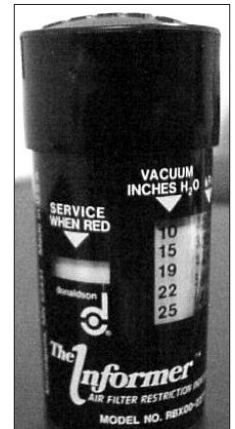

*The Informer.*

## AIR FILTER -CHANGING

When the air filter needs to be changed, the entire air filter cartridge is discarded and replaced by loosening the inlet and outlet ducting clamps and releasing the retaining band snaps. The air filter is located roadside in the last compartment.

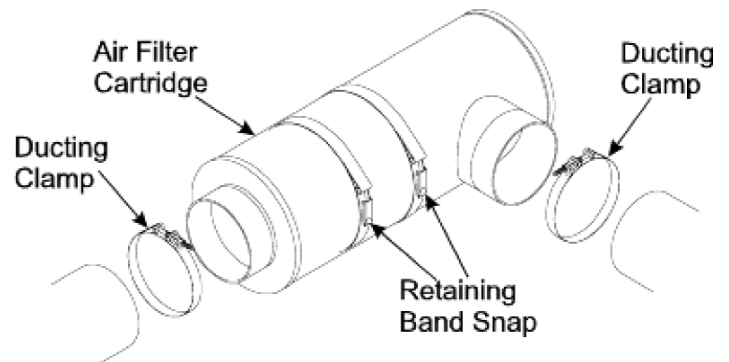

### Rear Bag Dump Solenoids

- Only used for the hydraulic leveling.
- Dumps air in the rear bags.
- Two air bag solenoids, one for each side.
- Location - Open rear the engine compartment door, the solenoids are located on the curbside next to the radiator.

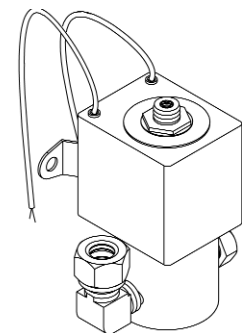

*Rear Bag Dump Solenoids.*

### Front Bag Dump Solenoid

- Only used on hydraulic leveling.
- Dumps the air in the front air bags.
- Location - Open the generator door and the solenoid is located on the center front firewall.

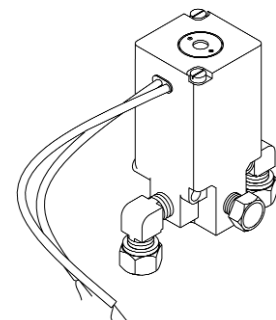

*Front Bag Dump Solenoid.*



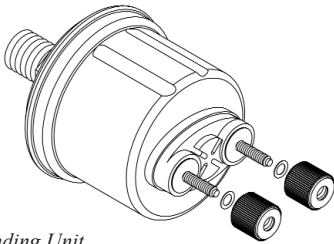

*Sending Unit.*

### **Sending Unit Locations**

#### **Oil Pressure/Low Oil Pressure Warning Dual Post Sending Unit.**

- One post oil pressure.
- I.S.B. 260 engines, the sending unit is located on the curbside under the ECM.

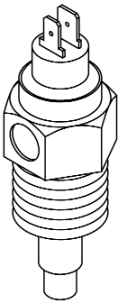

*Water Temperature Sender.*

#### **Water Temperature/High Water Temp Dual Post Sending Unit**

- One post water temperature.
- I.S.B. 260 engines, the sending unit is located in the engine block.

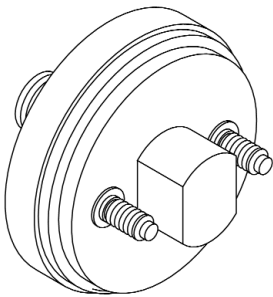

*Low Air Switch.*

#### **Low Air Switch**

- 1/8-27 NPTF thread.
- Actuates at 66 psi.
- Single pole, two terminal.
- Switch used to illuminate park brake lamp under left dash console.
- Switch used to illuminate low air lamp located behind dash cluster.

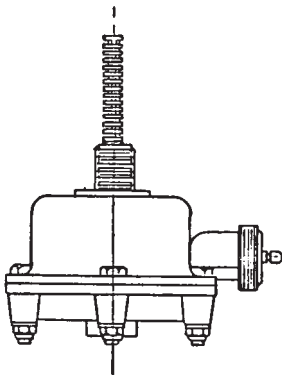

*Drain Valve.*

#### **Automatic Drain Valve**

- Momentary release of air/water.
- Activated through brake light circuit.
- Located WET side of the Air Storage tank.

- 12 Volt DC test light, this may be helpful on the phone with a technician.
- Battery hydrometer, to check each battery cell during maintenance.
- One 12-volt continuous duty solenoid.
- An assortment of spare fuse.
- One link kit for ride height control assembly.
- A spare alternator belt.
- Hump hose clamp for the Charge Air Cooler.

## CHECKLIST - ITEMS TO CARRY

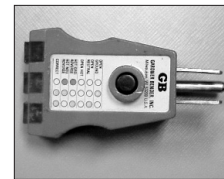

Polarity Tester

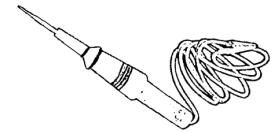

Test Light



Hose Clamp



Link

Chassis Specs	34' Model	36' Model
GVWR	22,000	22,000
GCWR	26,000	26,000
GAWR Front	8,000	8,000
GAWR Rear	14,000	14,000
Wheel Base	204"	228"
Overall Length	34.4	36.4
Overall Height	12'	12'
Interior Height	6'6"	6'6"
Interior Width	94.75"	94.75"
Exterior Width	100.5"	100.5"

## CHASSIS SPECIFICATIONS

## TANK CAPACITIES

Model	34'	36'
Water Heater	10	10
Gray Holding Tank	52	52
Black Holding Tank	52	52
Fresh Water Tank	80	80
LP Gas Tank 204"	38	38



**NOTE:** Actual filled LP capacity is 80% of listing due to safety shut off required on tank

---

## ENGINE SPECIFICATIONS

Engine Specifications	Chassis
Cummins ISB	260
Cubic Inch Displacement	359 5.9L
Tire Size <sup>2</sup>	255/70R22.5
Fuel Tank (Approx. Gal)	75
Alternator	160 Amps
Rear Axle Ratio	4.88:1

**CHASSIS INFORMATION**

Date	Mileage	Dealer Address	Service/Remarks

## **GLOSSARY OF TERMS**

**AC Electricity** - Alternating current also known as household power.

**Ampere (Amp)** - The unit of measure of electron flow rate of current through a circuit.

**Ampere-hour (Amp-hr. AH)** - A unit of measure for a battery electrical storage capacity, obtained by multiplying the current in amperes by the time in hours of discharge (Example; a battery which delivers 5 amperes for 20 hours, delivers 5 amperes times 20 hours, or 100 Amp-Hr. of capacity.)

**Black Water** - Term associated with the sewage holding tank. The toilet drains directly into this tank.

**Chassis Battery** - Powers chassis 12V accessories and starts engine.

**Circuit** - An electric circuit is the path of an electric current. A closed circuit has a complete path. An open circuit has a broken or disconnected path.

**City Water** - A term associated with the water supply that you hook-up to when you are at campgrounds. It is called city water because you pull water from a central source (like in a city) and not the fresh water tank.

**Curbside** - This refers to the side of the motorhome which faces the curb when it is parked. Often called the door side.

**Current (Alternating) (AC)** - A current that varies periodically in magnitude and direction. A battery does not deliver alternating current. Also referred to as shore power, utility power, inverter power, generator power, etc..

**Current** - The rate of flow of electricity or the movement rate of electrons along a conductor. It is comparable to the flow of a stream of water. The unit of measure for current is the ampere.

**Cycle** - In a battery, one discharge plus one recharge equals one cycle.

**DC Electricity** - Direct current also known as battery power.

**Direct Current (DC)** - Power that is stored in a battery bank or supplied by photovoltaics, alternator, chargers and DC generators.

**Drain Trap** - This is a curve that is in all drains. Water is trapped in the curve and this creates a barrier so tank odors cannot escape through the drain.

**Dry Camping** - Camping in the motorhome when there is no city water hook-up or shore power. In other words, using only the water and power that is in the motorhome and not anything from another source.

**Dump Station** - Sites where you can drain your waste (gray) and sewage (black) tanks. In most states it is illegal to drain your tanks anywhere except at dump stations.

**Dump Valve** - Another name for the T-handle valve used to drain the sewage (black) and waste (gray tanks).

**Egress Window** - The formal name for the emergency window located in the rear of the motorhome. Egress windows can be easily identified by their red handles.

**Full Hook-Up Site** - A camp ground that has city water, shore power and sewer hook-ups or connections available.

**Gray Water** - Term associated with the waste water holding tank. Water from the sink drains, the shower and the washer/dryer (if equipped) go into this tank.

**House Battery** - Powers 12V lights and accessories inside motorhome.

**LED** - (Light Emitting Diode) Indicator light.

**Low Point** - The lowest point in the plumbing. Drains are placed here so that water will drain out of the lower end of the motorhome. These drains must be closed when you fill the water tank.

**OHM** - A unit for measuring electrical resistances.

**Ohm's Law** - Express the relationship between volt (E), amperes (I) in an electrical circuit with resistance (R). It can be expressed as follows:  $E = IR$  If any two of the three values are known, the third value can be calculated by using the above formula.

**Road Side** - This refers to the side of the motorhome which faces the road when it is parked. Often called the off-door side.

**Shore Line** - This is the electrical cord which runs from the motorhome to the camp ground 120 volt electrical supply.

**Shore Line Plug** - This is the 120 volt outlet that you can plug your motorhome into a campground.

**Stinger** - An arm attachment on a tow truck that is used to lift motorhome slightly so that it can be towed.

**Volt** - The unit of measure for electric potential.

**Watt** - The unit for measuring electrical power, i.e., the rate of doing work, in moving electrons by or against an electric potential.

**Wet Cell Battery** - A type of battery that uses liquid as an electrolyte. This type of battery requires periodic maintenance such as cleaning the connections and checking the electrolyte level.

**NOTES**